

5A Low Dropout Positive Adjustable Regulator

TO-252
(DPak)

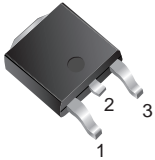

Six1084CE

TO-220AB

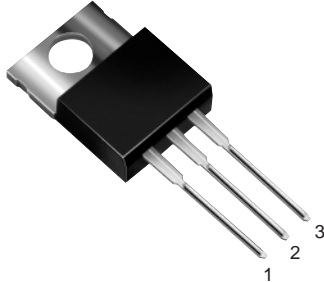

Six1084CT

TO-263AB
(D²Pak)

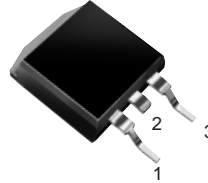

Six1084CM

Pin Definition

1. Adjust/Gnd.
2. V_{out} (tab)
3. V_{in}

Features

- Dropout Voltage 1.3V at 5A Output Current
- Fast Transient Response
- Line Regulation typically at 0.015%
- Load Regulation typically at 0.1%
- Internal thermal and current limiting
- Adjustable Output Voltage or Fixed 1.8V, 2.5V, 3.3V
- Standard 3-Pin Power Packages

Description

The Six1084 is a low dropout three terminal regulator with 5A output current capability. The output voltage is adjustable with the use of a resistor divider. For fixed output voltage versions, the output voltage is internally set at 1.8V, 2.5V, or 3.3V. Dropout is guaranteed at a maximum of 1.4V at maximum output current. Its low dropout voltage and fast transient response make it ideal for low voltage microprocessor applications. Internal current and thermal limiting provides protection against any overload condition that would create excessive junction temperatures.

Applications

- Post Regulator for Switching Supply
- Microprocessor Power Supplies
- Constant-Current Regulators
- Motherboard I/O Power Supplies

Functional Block Diagram

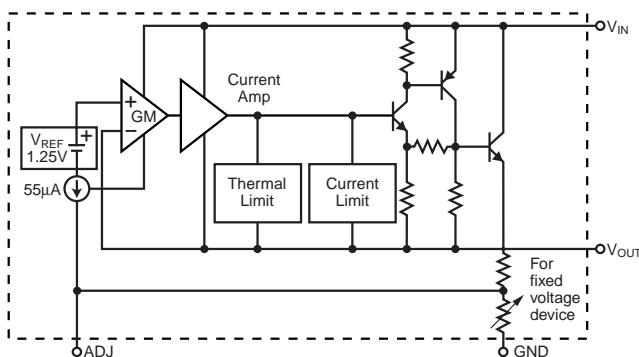

Mechanical Data

Case: TO-220AB, TO-263AB (D²PAK), TO-252 (DPAK)

High temperature soldering guaranteed:
260°C/10 seconds at terminals

Case outlines are on the back page

Maximum Ratings and Thermal Characteristics ($T_A = 25^\circ\text{C}$ unless otherwise noted)

Parameter	Symbol	Value	Unit
Vin Pin to ADJ/GND Pin	Vin	7	V
Thermal Resistance – Junction to Case	$R_{\theta JC}$	3.0 8.0 3.0	$^\circ\text{C/W}$
Operating Junction Temperature Range	T_J	0 to +125	$^\circ\text{C}$
Storage Temperature Range	T_{stg}	-65 to 150	$^\circ\text{C}$

Electrical Characteristics⁽¹⁾ $T_J = 25^\circ\text{C}$ ⁽²⁾, $V_{IN} = 5\text{V}$, $I_o = 10\text{mA}$ unless otherwise noted.

Parameter	Symbol	Test Conditions	Min	Typ	Max	Unit
Reference Voltage	V_{REF}	$T_J = 25^\circ\text{C}$ $0^\circ\text{C} \leq T_J \leq 125^\circ\text{C}$ $2.65\text{V} \leq V_{IN} \leq 7\text{V}$ $10\text{mA} \leq I_o \leq 5\text{A}$	1.238 1.225	1.250 1.250	1.262 1.275	V
Output Voltage	V_{OUT}	Six1084-1.8 $V_{IN} = 5\text{V}$ Six1084-2.5 $V_{IN} = 5\text{V}$ Six1084-3.3 $V_{IN} = 7\text{V}$ Six1084 $0^\circ\text{C} \leq T_J \leq 125^\circ\text{C}$ $2.65\text{V} \leq V_{IN} \leq 7\text{V}$ $10\text{mA} \leq I_o \leq 5\text{A}$	1.78 2.47 3.26 0.98 V_N	1.8 2.5 3.3 V_N	1.82 2.53 3.33 1.02 V_N	V
Line Regulation	REG_{line}	$2.65\text{V} \leq V_{IN} \leq 7\text{V}$ $T_J = 25^\circ\text{C}$ $0^\circ\text{C} \leq T_J \leq 125^\circ\text{C}$		0.015 0.035	0.2 0.2	% V_O
Load Regulation	REG_{load}	$10\text{mA} \leq I_o \leq 5\text{A}$ $T_J = 25^\circ\text{C}$ $0^\circ\text{C} \leq T_J \leq 125^\circ\text{C}$		0.1 0.2	0.3 0.4	% V_O
Dropout Voltage	V_{DROP}	$0^\circ\text{C} \leq T_J \leq 125^\circ\text{C}$ $I_o = 5\text{A}$ $I_o = 3\text{A}$ $I_o = 1\text{A}$		1.3 1.23 1.15	1.4 1.32 1.25	V
Output Current	I_o	$0^\circ\text{C} \leq T_J \leq 125^\circ\text{C}$	5.0	6.0	–	A
Adjust Pin Current	I_{adj}	$2.65 \leq V_{in} \leq 7\text{V}$ $10\text{mA} \leq I_o \leq 5\text{A}$ $0^\circ\text{C} \leq T_J \leq 125^\circ\text{C}$	–	55	120	μA
Adjust Pin Current Change	ΔI_{adj}	$2.65 \leq V_{in} \leq 7\text{V}$ $10\text{mA} \leq I_o \leq 5\text{A}$ $0^\circ\text{C} \leq T_J \leq 125^\circ\text{C}$	–	0.2	5	μA
Temperature Stability	T_S	$I_o = 0.5\text{A}$, $0^\circ\text{C} \leq T_J \leq 125^\circ\text{C}$	–	0.8	–	% V_O
Min. Load Current Adjustable Version	I_{LMIN}	$0^\circ\text{C} \leq T_J \leq 125^\circ\text{C}$	–	3	10	mA

Electrical Characteristics (con't.)⁽¹⁾ $T_J = 25^\circ\text{C}$ ⁽²⁾, $V_{IN} = 5\text{V}$, $I_o = 10\text{mA}$ unless otherwise noted.

Parameter	Symbol	Test Conditions	Min	Typ	Max	Unit
Quiescent Current Fixed Voltage Version	I_Q	$0^\circ\text{C} \leq T_J \leq 125^\circ\text{C}$	–	10	14	mA
RMS Output Noise	N	$10\text{Hz} \leq f \leq 10\text{kHz}$	–	0.003	–	% V_O
Ripple Rejection Ratio	RR	$f = 120\text{Hz}$, $C_O = 25\mu\text{F}$ $C_{adj} = 25\mu\text{F}$	60	68	–	dB
Thermal Regulation	R_{TH}	$T_A = 25^\circ\text{C}$, 30ms Pulse	–	0.02	0.05	%/W
Long Term Stability		$T_A = 125^\circ\text{C}$, 1000 Hrs	–	0.3	–	% V_O

Notes:

- (1) All parameters, except nominal output voltage are specified for the variable voltage version, allowing a wider V_{in} Range.
 The specified limits also apply for the fixed voltage versions over the allowable input voltage range: Six1084-1.8 (3.2V - 7.0V), Six1084-2.5 (3.9V - 7.0V), Six1084-3.3 (4.75V - 7.0V).
- (2) To maintain the specified junction temperatures, low duty cycle pulse testing is required for most parameters.

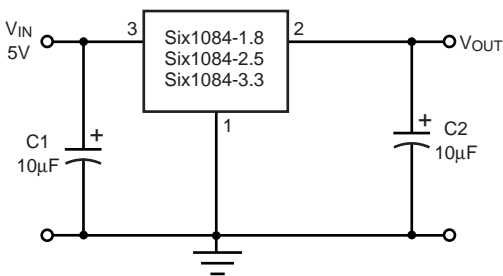
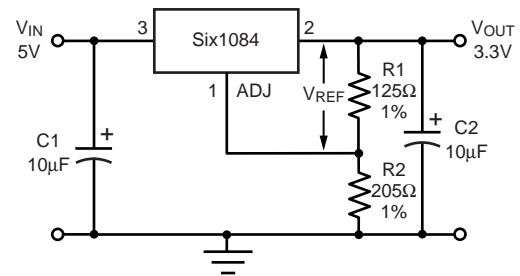
Typical Application Circuit

Fixed Voltage Regulator

Adjustable Voltage Regulator
Notes:

$$V_{REF} = V_{OUT} - V_{ADJ} = 1.25\text{V (typ.)}$$

$$V_{OUT} = V_{REF} \times (1 + R2/R1) + I_{ADJ} \times R2$$

$$I_{ADJ} = 55\mu\text{A (typ.)}$$

- (1) C1 needed if device is far away from filter capacitors
 (2) C2 required for stability

Ratings and Characteristic Curves ($T_A = 25^\circ\text{C}$ unless otherwise noted)

Fig. 1 – Dropout Voltage vs. Output Current

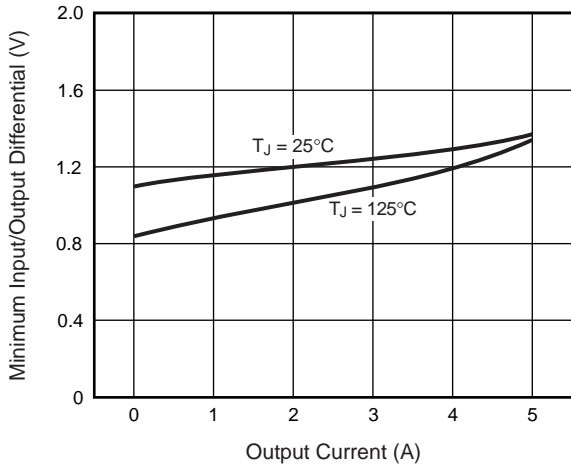

Fig. 2 – Load Regulation vs. Temperature

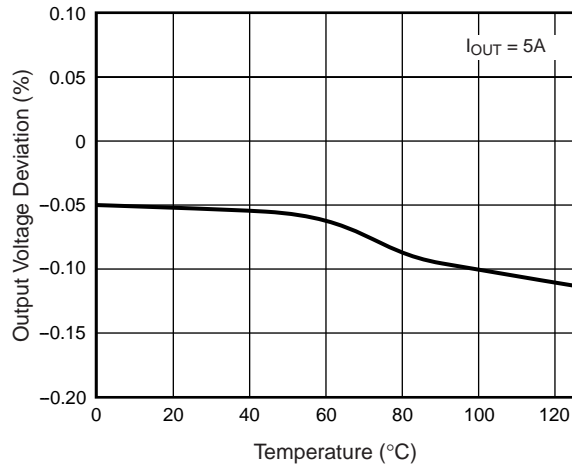

Fig. 3 – Minimum Load Current (Adjustable Version)

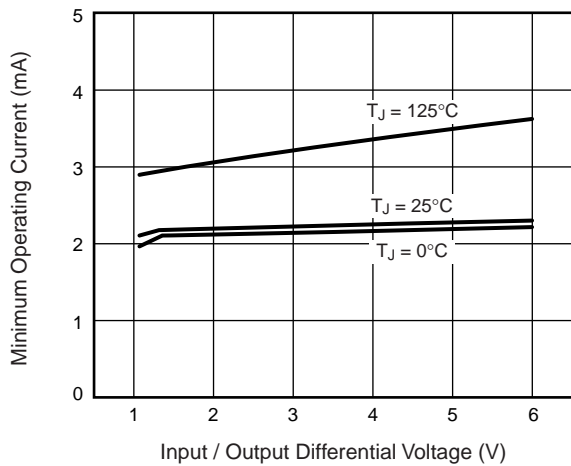

Fig. 4 – Adjust Pin Current

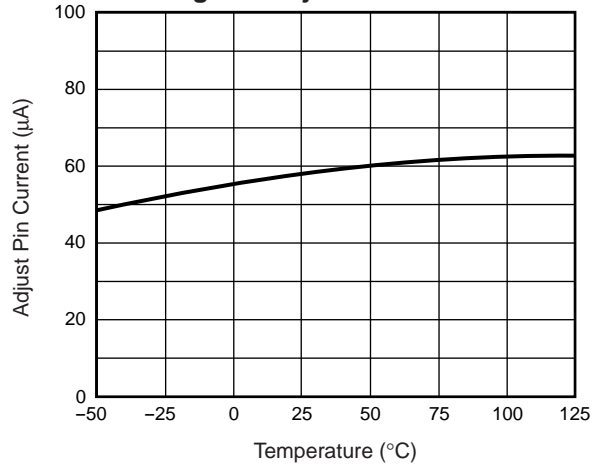

Fig. 5 – Temperature Stability

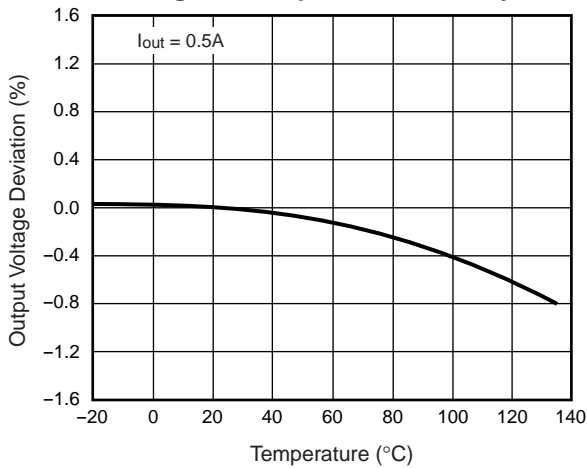
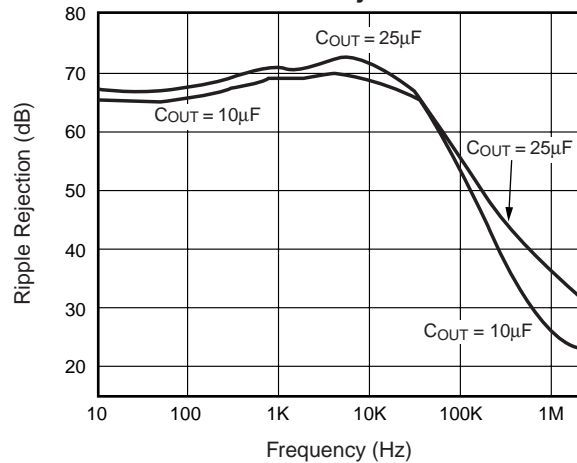

Fig. 6 – Ripple Rejection (with $C_{adj} = 25\mu\text{F}$)



Ratings and Characteristic Curves ($T_A = 25^\circ\text{C}$ unless otherwise noted)

Fig. 7 – Load Transient Response

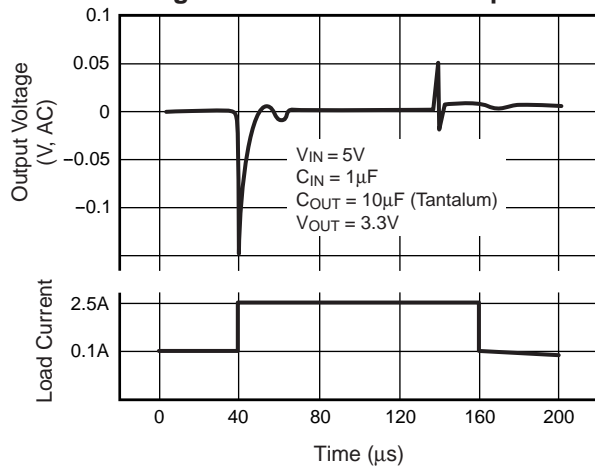
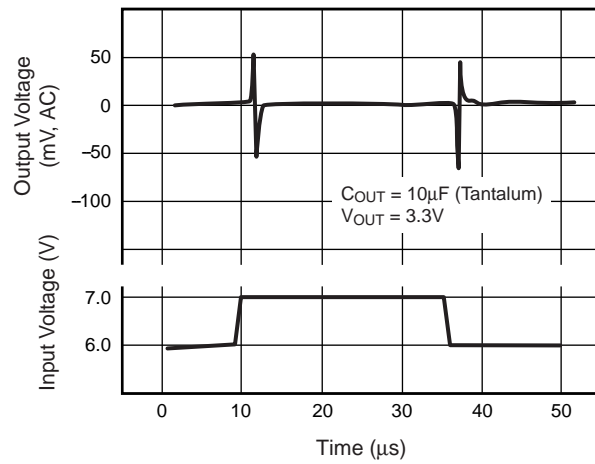

Fig. 8 – Line Transient Response



Ordering Information

Six1084Cxx xxx

↑

Package Type

T: TO-220
M: TO-263
E: TO-252

↑

Output Voltage

Default: Adj.

1.8: 1.8V
2.5: 2.5V
3.3: 3.3V

Case Outlines

TO-252 (DPAK)

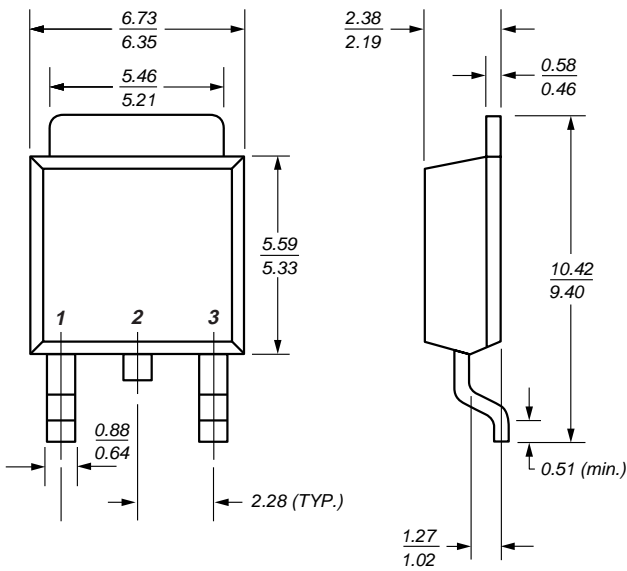

TO-220 Case Outline

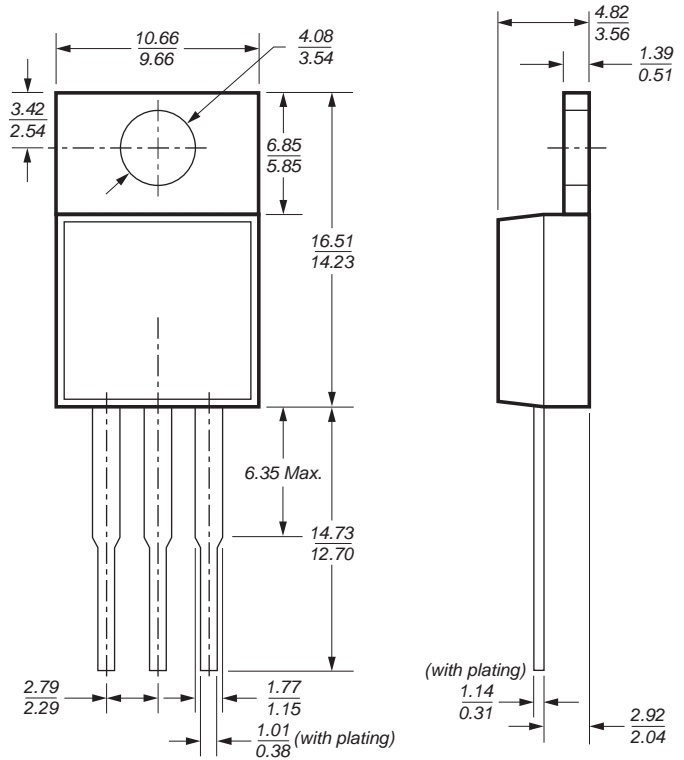

TO-263 Case Outline

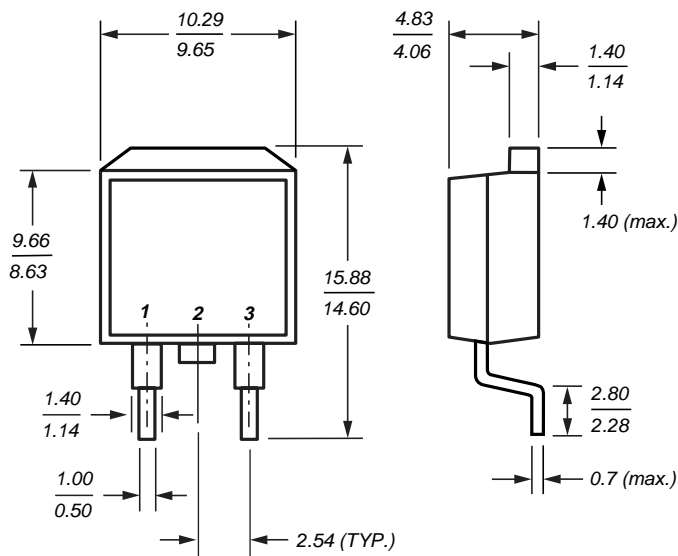

Dimensions in millimeters