

REV.	DESCRIPTION	DATE	BY	APP'D
D	NPR 1629	1/5/00	JMH	

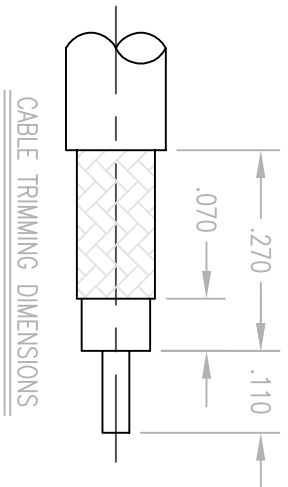
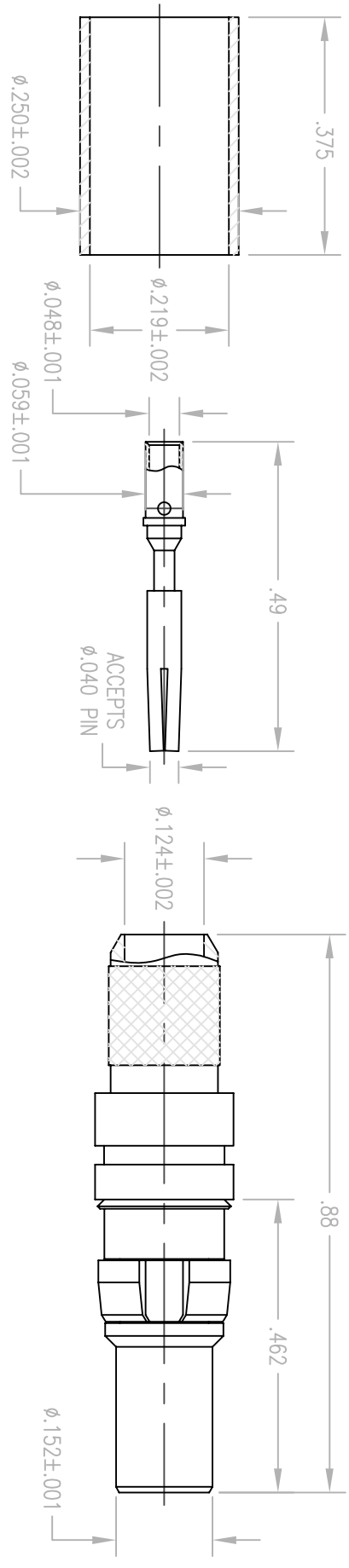

- NOTES:
1. MATERIALS:  
 BODY AND FERRULE: BRASS PER ASTM B16  
 CONTACT: BERYLLIUM COPPER PER ASTM B196  
 CLIP RING: PHOSPHOR BRONZE PER ASTM B103  
 INSULATOR: TEFLON PER ASTM D1710
  2. FINISH:  
 BODY AND CONTACT: .000030 MIN. GOLD PER MIL-G-45204 OVER  
 .000050 MIN. NICKEL PER QQ-N-290  
 FERRULE: .000005 MIN. GOLD PER MIL-G-45204 OVER  
 .000050 MIN. NICKEL PER QQ-N-290  
 CLIP RING: .000100 MIN. NICKEL PER QQ-N-290 OVER  
 COPPER FLASH
  3. FOR USE WITH RG-142 OR EQUIVALENT CABLE.
  4. FOR ASSEMBLY SEE CAP 9-07.

PER ASME Y14.5M-1994 UNLESS OTHERWISE SPECIFIED: DIMENSIONS ARE IN INCHES OR DECIMALS THEREAFTER. XX ± .01/0.254 DIMENSIONS .XX ± .005/0.127 ANGLES ± Z°		SCALE: 4:1	
DRAWN EW		CHECKED JED	
DATE 7/2/99		DATE 7/2/99	
APPROVED JMC		APPROVED JMC	
CUSTOMER DRAWING		TITLE	
RDM CRIMP/CRIMP PLUG		Litton Winchester Electronics/RETCONN	
260-910-1161G		400 Paul Road Westborough, Connecticut 01581	
SHT.	1	OF	1
REV.	D		