

TYPE 1.

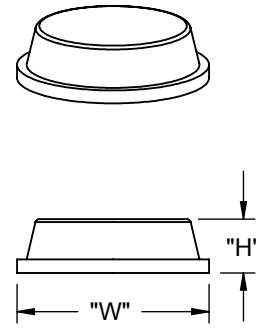

TYPE 2.

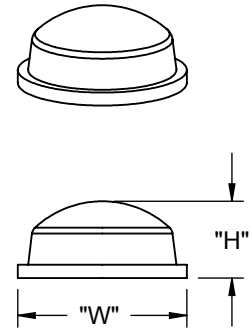

TYPE 3.

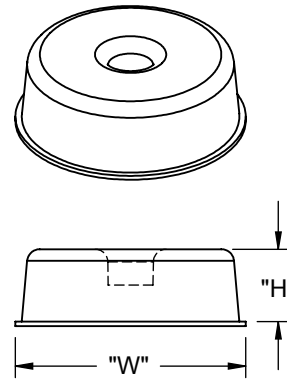

TYPE 4.

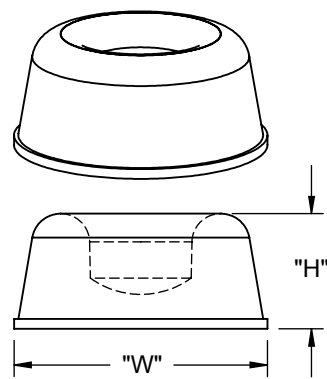

TYPE 5.

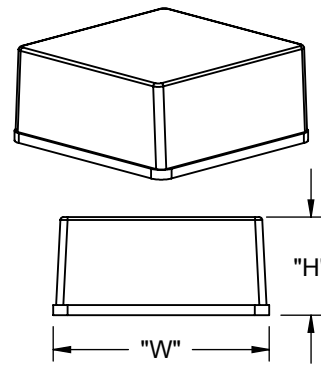

TYPE 6.

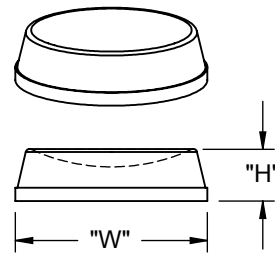

TYPE 7.

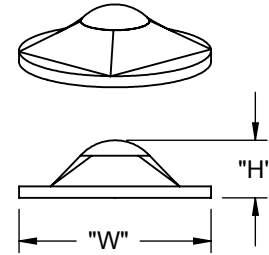

TYPE 8.

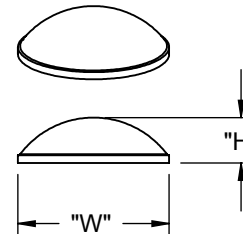

TYPE 9.

PART NO.	DIA. (OR "W") ±.020 [±0.5]	HEIGHT "H" ±.020 [±0.5]	6 X 12 MATRIX KISS CUT PAD PCS/PAD	TYPE	QTY. CTN
RBS-3R	.50 [12.7]	.23 [5.8]	200	1 (PYRAMID)	5000
RBS-19	.81 [20.5]	.30 [7.6]	98		2646
RBS-20	.40 [10.2]	.10 [2.5]	242		5082
RBS-29	.78 [19.8]	.25 [6.4]	98		2940
RBS-32R		.12 [3.1]			5000
RBS-1	.50 [12.7]	.14 [3.5]	200	2 (CYLINDRICAL)	5000
RBS-5		.06 [1.6]			5000
RBS-6		.25 [6.3]			5000
RBS-11	.62 [15.9]	.40 [10.1]	128		2560
RBS-24	.81 [20.5]	.12 [3.1]	72		2520
RBS-34	.37 [9.5]		300		6000
RBS-35		.19 [4.8]	200		5000
RBS-41	.78 [20.0]	.20 [5.1]	84		3360
RBS-44	.75 [19.1]	.16 [4.1]	98		2450
RBS-72	1.24 [31.5]	.10 [2.5]	32	2400	
RBS-2	.44 [11.1]	.20 [5.1]	242	3 (DOMES)	5082
RBS-7	.34 [8.6]	.08 [2.2]	450		5400
RBS-8	.70 [17.6]	.38 [9.6]	98		2254
RBS-12	.38 [9.6]	.15 [3.8]	72		7200
RBS-15	.62 [16.0]	.31 [7.9]	128		3200
RBS-22	.38 [9.6]	.21 [5.4]	300		6000
RBS-27	.31 [7.9]	.08 [2.2]	450		5400
RBS-37	.72 [18.3]	.56 [14.2]	100 SEPARATE PARTS		1500
RBS-39	.75 [19.1]	.07 [1.9]	84		5040
RBS-40	.25 [6.4]	.06 [1.6]	578		15028
RBS-30	1.8 [45.7]	.60 [15.8]	100 SEPARATE PARTS	4 (ROUND)	500
RBS-17	.88 [22.3]	.40 [10.1]	72	5 (ROUND)	1440
RBS-4	.78 [19.8]	.38 [9.7]	100 SEPARATE PARTS	6 (SQUARE)	5600
RBS-36	1.00 [25.4]	.18 [4.7]	55		2310
RBS-18	.50 [12.7]	.14 [3.5]	200	7 (ROUND)	5000
RBS-33-SD		.15 [3.8]		8 (ROUND-PYRAMID)	5000
RBS-10	.39 [10]	.12 [3]	288	9 (DOMES)	7200

- NOTES:
 1. MATERIAL: POLYURETHANE (RMS-64), 60-70 DUROMETER, SHORE A.
 2. STANDARD COLOR: CLEAR AND BLACK: TO ORDER BLACK ADD "-BK" TO PART NO. BROWN "-BN", WHITE "-WH", OR GRAY "-GY" AVAILABLE BY SPECIAL ORDER ONLY. PART NO. RBS-33-SD AND RBS-10 AVAILABLE IN CLEAR ONLY.
 3. ADHESIVE: RUBBER (RMS-68).
 4. LIGHTER BUMPER COLORS MAY SHOW SOME DARKENING OR YELLOWING WHEN NOT STORED IN ORIGINAL UNOPENED CARTON.
 *NON STAINING, NON MARRING.
 *CRACK RESISTANT.

REV.	DESCRIPTION	ENGR.	DATE
V	SEE ECN #1346 FOR CHANGES	SK	07/24/07
U	SEE ECN #1344 FOR CHANGES	SK	07/12/07
T	SEE ECN #1200 FOR CHANGES	SK	07/21/06
S	SEE ECN #1174 FOR CHANGES	SK	05/18/06
R	SEE ECN #1064 FOR CHANGES	SK	09/30/05
Q	SEE ECN #1024 FOR CHANGES	SK	07/13/05
P	SEE ECN #906 FOR CHANGES	SM	01/06/05
O	COMPLETELY REDRAWN, SEE ECN #834	SM	08/12/04
-	SEE ENGINEERING FOR REV. A-N	-	----

TITLE: RICHCO BUMPERS		DWG IN IN [MM]		FINAL	
CREATED USING SOLIDWORKS	FILE #: RBS	DWN: SM	APP: DJZ	PART #	
TOLERANCES UNLESS NOTED .XX=±.010 .XXX=±.005 FRAC.=±1/64 ANG.=±1°	SHEET: 1 OF 1 SHEET SIZE: B	DT: 08/12/04	CHKD: RG	SEE TABLE	
RE: RICHCO, INC.		RICHCO, INC. ENG@RICHCO-INC.COM (773) 539-4060		PRINT TYPE CA	