

SPS-6110WG / SPS-6110BWG / SPS-6110AWG

(RoHS Compliant)

16G FC / 1310 nm / 10 km Digital Diagnostic SFP+ LC SINGLE-MODE TRANSCEIVER

FEATURES

- | Up to 14.025 Gbps Bi-directional Data Links
- | Compliant with SFP+ MSA
- | Compliance with Fibre Channel 1600-SM-LC-L
- | Compliant with 8G and 4G Fibre Channel
- | SFF-8472 Digital Diagnostic Function
- | 1310 nm DFB LD Transmitter
- | AC/AC Coupling according to MSA
- | **2 to 10,000 m at 14.025 Gbps**
- | Single +3.3 V Power Supply
- | RoHS 6/6 Compliant
- | 0 to 70°C Operating: SPS-6110WG
- | -5 to 85°C Operating: SPS-6110BWG
- | -40 to 85°C Operating: SPS-6110AWG
- | Class 1 Laser International Safety Standard IEC-60825 Compliant

APPLICATIONS

- | Multi-rate 16x / 8x / 4x Fibre Channel
- | 10G FCoE
- | 10G Ethernet

DESCRIPTION

The SPS-6110WG series single mode transceiver is small form factor pluggable module for bi-directional serial optical data communications such as 16x/8x/4x Fibre Channel. It is with the SFP+ 20-pin connector to allow hot plug capability. Digital diagnostic functions are available via an I²C. This module is designed for single mode fiber and operates at a nominal wavelength of 1310 nm. The transmitter section uses a 1310 nm multiple quantum well DFB laser and is a class 1 laser compliant according to International Safety Standard IEC-60825. The receiver section uses an integrated InGaAs detector preamplifier (IDP) mounted in an optical header and post amplifier IC.

LASER SAFETY

This single mode transceiver is a Class 1 laser product. It complies with IEC-60825 and FDA 21 CFR 1040.10 and 1040.11. The transceiver must be operated within the specified temperature and voltage limits. The optical ports of the module shall be terminated with an optical connector or with a dust plug.

ORDER INFORMATION

P/No.	Bit Rate (Gb/s)	FC	Distance (km)	Wavelength (nm)	Package	Temp. (°C)	RoHS Compliant
SPS-6110WG	14.025	16G / 8G / 4G	10	1310 DFB	SFP+ with DMI	0 to 70	Yes
SPS-6110BWG	14.025	16G / 8G / 4G	10	1310 DFB	SFP+ with DMI	-5 to 85	Yes
SPS-6110AWG	14.025	16G / 8G / 4G	10	1310 DFB	SFP+ with DMI	-40 to 85	Yes

Absolute Maximum Ratings

Parameter	Symbol	Min	Max	Units	Notes
Storage Temperature	Tstg	-40	85	°C	
Operating Case Temperature	Topr	0	70	°C	SPS-6110WG
		-5	85		SPS-6110BWG
		-40	85		SPS-6110AWG
Power Supply Voltage	Vcc	-0.5	3.6	V	

Recommended Operating Conditions

Parameter	Symbol	Min	Typ	Max	Units / Notes
Power Supply Voltage	Vcc	3.13	3.3	3.47	V
Operating Case Temperature	Topr	0		70	°C / SPS-6110WG
		-5		85	°C / SPS-6110BWG
		-40		85	°C / SPS-6110AWG
Power Supply Current	I _{CC(TX+RX)}		220	300	mA
Data Rate		4.25	14.025		Gb/s

Transmitter Optical Specifications (0°C < Topr < 70°C, 3.13V < Vcc < 3.47V)						
Parameter	Symbol	Min	Typ	Max	Units	Notes
Optical Modulation Amplitude	P _{O, OMA}	-2		+2	dBm	
Average Launch Power	P _{O, Avg}	-4		+2	dBm	1
Extinction Ratio	ER	3.5				
Output Center Wavelength	λ _c	1295		1325	nm	
Output Spectrum Width	σ _λ			1	nm	-20 dB width
Side Mode Suppression Ratio	SMSR	30			dB	
Transmitter and Dispersion Penalty	TDP			4.4	dB	
Relative Intensity Noise	RIN			-130	dB/Hz	
Average Launch Power of OFF Transmitter				-30	dBm	

1. Output power is power coupled into a 9/125 μm single-mode fiber.

Receiver Optical Specifications (0°C < Topr < 70°C, 3.13V < Vcc < 3.47V)						
Parameter	Symbol	Min	Typ	Max	Units	Notes
Unstressed Sensitivity at 14.025 Gb/s	Sens			-12	dBm	2, OMA
				-10.9	dBm	3, Average Power
Stress Sensitivity at 14.025 Gb/s	Sens		---	-10.2	dBm	2, OMA
Receiver Overload	P _{MAX}	2	---		dBm	
LOS -- Deasserted	LOS _D	---	---	-12	dBm	Transition: low to high
LOS -- Asserted	LOS _A	-22	---	---	dBm	Transition: high to low
Wavelength of Operation	λ _c	1260		1565	nm	
Optical Return Loss	ORL			-12	dB	

2. Measured with worst ER; BER < 10⁻¹² and PRBS 2³¹-1.

3. Represents sensitivity based on OMA spec, as corrected to incoming Extinction Ratio of 3.5 dB. For example, an OMA of 0.063 mW (-12 dBm) is approximately equal to an average power of -10.9 dBm, average with an Extinction ratio of 3.5 dB.

Electrical Characteristics						
Parameter	Symbol	Min	Typ	Max	Units	Notes
High-Speed Signal (CML) Interface Specification						
Input Data Rate		4.25	14.025		Gb/s	
TX Clock Tolerance				±100	ppm	4
Differential Input Impedance	R _{in}		100		Ω	
Differential Data Input Amplitude		150		1200	mVpp	Internally AC coupled
Output Data Rate		4.25	14.025		Gb/s	
RX Clock Tolerance				±100	ppm	4
Differential Output Impedance	R _{out}		100		Ω	
Differential Data Output Amplitude		350	600	700	mVpp	Internally AC coupled
Low-Speed Signal (LVTTTL) Interface Specification						
Input High Voltage		2.0		V _{cc} +0.3	V	
Input Low Voltage		GND		0.8	V	
Output High Voltage		2.4		V _{cc}	V	
Output Low Voltage		GND		0.5	V	

4. Clock tolerance for 14.025 Gb/s, 8.5Gb/s and 4.25 Gb/s.

CONNECTION DIAGRAM

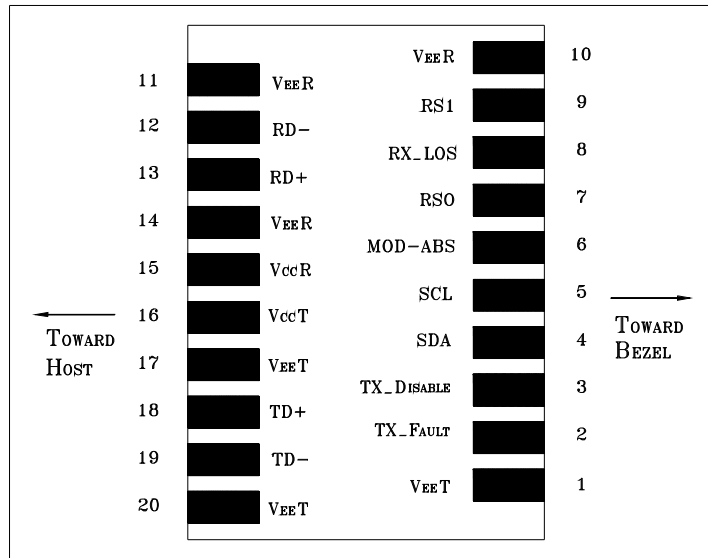

PIN	Signal Name	Description	PIN	Signal Name	Description
1	V _{EE} T	Transmitter Signal Ground	11	V _{EE} R	Receiver Signal Ground
2	TX_Fault	Transmitter Fault Indication. Logic “1” Output = Laser Fault. Logic “0” Output = Normal Operation	12	RD-	Inverse Receiver Data Out
3	TX_Disable	Logic “1” Input (or no connection) = Laser off, Logic “0” = Laser on.	13	RD+	Receiver Data Out
4	SDA	Modulation Definition 2 – Two wires serial ID Interface	14	V _{EE} R	Receiver Signal Ground
5	SDL	Modulation Definition 1 – Two wires serial ID Interface	15	V _{CC} R	Receiver Power – 3.3V±5%
6	MOD-ABS	Modulation Definition 0 – Ground in Module	16	V _{CC} T	Transmitter Power – 3.3V±5%
7	RS0	RX Rate Select: This pin has an internal 30k pulldown to ground. A signal on this pin will not affect module performance.	17	V _{EE} T	Transmitter Signal Ground
8	RX_LOS	Loss of Signal Out (OC).	18	TD+	Transmitter Data In
9	RS1	TX Rate Select. This pin has an internal 30k pulldown to ground. A signal on this pin will not affect module performance.	19	TD-	Inverse Transmitter Data In
10	V _{EE} R	Receiver Signal Ground	20	V _{EE} T	Transmitter Signal Ground

MODULE DEFINITION

Module Definition	PIN 4	PIN 5	PIN 6	Interpretation by Host
4	SDA	SCL	MOD-ABS	Serial module definition protocol

Module Definition 4 specifies a serial definition protocol. For this definition, upon power up, SDA and SDL appear as no connector (NC) and MOD-ABS is TTL LOW. When the host system detects this condition, it activates the serial protocol. The protocol uses the 2-wire serial CMOS E²PROM protocol of the ATMEL AT24C01A/02/04 family of components.

RECOMMENDED CIRCUIT SCHEMATIC

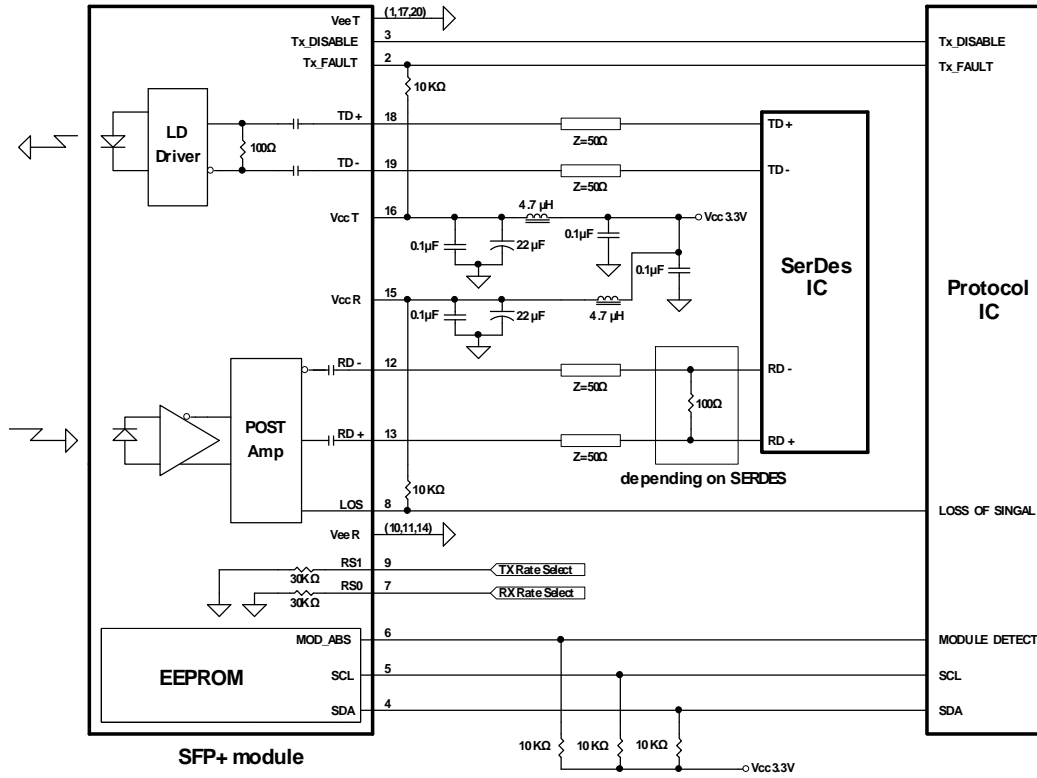

PACKAGE DIAGRAM

Units in mm

Top View

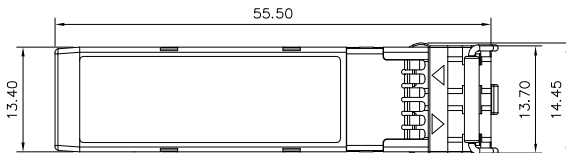

Front View

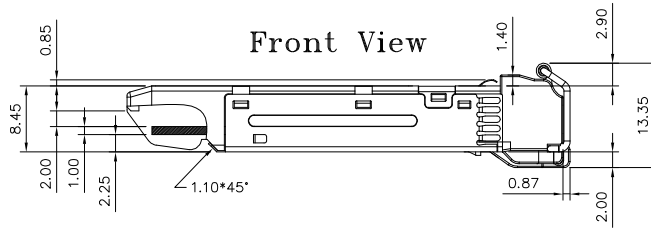

LATCH COLOR
BLUE :SM

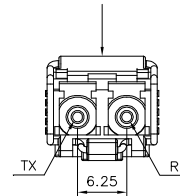

Side View

Bottom View

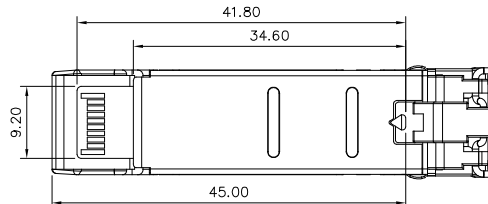

Note: Specifications subject to change without notice.

EEPROM Series ID Memory Contents (Address A0h)

Addr.	Hex	ASCII	Note	Addr.	Hex	ASCII	Note	Addr.	Hex	ASCII	Note	Addr.	Hex	ASCII	Note	
0	03		SFP+	32	20		Vendor IEEE OUI	64	00		Uncooled Tx,	96	00		Vendor specific EEPROM	
1	04			33	20			65	1A		Txdis, Txfault, LOS enable	97	00			
2	07		LC	34	20			66	00		Up bit rate	98	00			
3	20		10G Base-LR	35	20			67	00		Low bit rate	99	00			
4	00			36	00			68			Serial number:	100	00			
5	00			37	00			69			each piece with	101	00			
6	00			38	0E			70			different serial	102	00			
7	10		Long Distance (L)	39	FA			71			number	103	00			
8	10		Longwave Laser (LL)	40	53	S		Part Number	72				104	00		
9	01		Single Mode (SM)	41	50	P			73				105	00		
10	F0		1600/1200/800/400 Mbytes/sec	42	53	S		74				106	00			
11	06		64B/66B	43	2D	-		75				107	00			
12	8C		14.025Gbps	44	36	6		76				108	00			
13	00			45	31	1		77				109	00			
14	0A		10km	46	31	1		78				110	00			
15	64		10km	47	30	0		79				111	00			
16	00			48	57	W		80				112	00			
17	00			49	47	G		81				113	00			
18	00			50	20			82				114	00			
19	00			51	20			83				115	00			
20	4F	O	Vendor name	52	20			84			Date Code	116	00			
21	50	P		53	20			85				117	00			
22	54	T		54	20			86				118	00			
23	4F	O		55	20			87				119	00			
24	57	W		56	30	0	Revision, depended on version	88				120	00			
25	41	A		57	30	0		89				121	00			
26	59	Y		58	30	0		90				122	00			
27	20			59	31	1		91				123	00			
28	20			60	05		1310 nm	92	68		Monitoring	124	00			
29	20			61	1E			93	F0		Soft Control and Monitoring	125	00			
30	20		62	00		Reserved	94	05		SFF-8472V11.0	126	00				
31	20		63			Checksum 0-62	95			Checksum 64-94	127	00				

EEPROM Series ID Memory Contents (Address A2h)

Addr.	Hex	Note	Addr.	Hex	Note	Addr.	Hex	Note	Addr.	Hex	Note
0	55	Temp. High Alarm (85°C)	32	4D	Rx Power High Alarm (3dBm)	64	00	For External Cal.	96		Real Time Temp. MSB
1	00		33	F1		65	00		For External Cal.	97	
2	FB	Temp. Low Alarm(-5°C)	34	02	Rx Power Low Alarm (-12.9dBm)	66	00	For External Cal.	98		Real Time Vcc MSB
3	00		35	01		67	00		For External Cal.	99	
4	50	Temp. High Warming(80°C)	36	3D	Rx Power High Warming (2dBm)	68	3F	For External Cal.	100		Real Time Tx Bias MSB
5	00		37	E9		69	80		For External Cal.	101	
6	00	Temp. Low Warming (0°C)	38	03	Rx Power Low Warming(-10.9dBm)	70	00	For External Cal.	102		Real Time Tx Pwr MSB
7	00		39	2D		71	00		For External Cal.	103	
8	8C	Voltage High Alarm (3.6V)	40	00	Reserved	72	00	For External Cal.	104		Real Time Rx Pwr MSB
9	A0		41	00	Reserved	73	00		For External Cal.	105	
10	75	Voltage Low Alarm(3.0V)	42	00	Reserved	74	00	For External Cal.	106		Reserved
11	30		43	00	Reserved	75	00		For External Cal.	107	
12	88	Voltage High Warming(3.5V)	44	00	Reserved	76	01	For External Cal.	108		Reserved
13	B8		45	00	Reserved	77	00		For External Cal.	109	
14	79	voltage Low Warming (3.1V)	46	00	Reserved	78	00	For External Cal.	110		Tx Dis, Tx Fault, Rx Los
15	18		47	00	Reserved	79	00		For External Cal.	111	
16	AF	Tx Bias High Alarm(90mA)	48	00	Reserved	80	01	For External Cal.	112		Alarm Flag
17	C8		49	00	Reserved	81	00		For External Cal.	113	
18	03	Tx BiasLow Alarm(2mA)	50	00	Reserved	82	00	For External Cal.	114		Reserved
19	E8		51	00	Reserved	83	00		For External Cal.	115	
20	9C	Tx Bias High Warming(80mA)	52	00	Reserved	84	01	For External Cal.	116		Warming Flag
21	40		53	00	Reserved	85	00		For External Cal.	117	
22	07	Tx Bias Low Warming(4mA)	54	00	Reserved	86	00	For External Cal.	118		Reserved
23	D0		55	00	Reserved	87	00		For External Cal.	119	
24	4D	Tx Power High Alarm (3dBm))	56	00	For External Cal.	88	01	For External Cal.	120		Vendor Specific
25	F1		57	00	For External Cal.	89	00		For External Cal.	121	
26	0C	Tx Power Low Alarm(-5dBm)	58	00	For External Cal.	90	00	For External Cal.	122		
27	5A		59	00	For External Cal.	91	00		For External Cal.	123	
28	3D	Tx Power High Warming(2dBm)	60	00	For External Cal.	92	00	For External Cal.	124		
29	E9		61	00	For External Cal.	93	00		For External Cal.	125	
30	0F	Tx Power Low Warming (-4dBm)	62	00	For External Cal.	94	00	For External Cal.	126		
31	8D		63	00	For External Cal.	95			Check Sum	127	

Note: Address 128 – 247: customer R/W eeprom. Address 248 – 255: Vendor Specific.

Note: Specifications subject to change without notice.

REVISION HISTORY

Version	Subject	Release Date
1.0	Initial datasheet	2011/7/1