

**SY3418 / SY3418(B)****1. Features**

- ◆ Yellow colored transparency lens type
- ◆  $\phi 3\text{mm}$ (T-1) all plastic mold type
- ◆ Wide viewing angle
- ◆ Low power consumption

**2. Outline Dimensions**

unit : mm

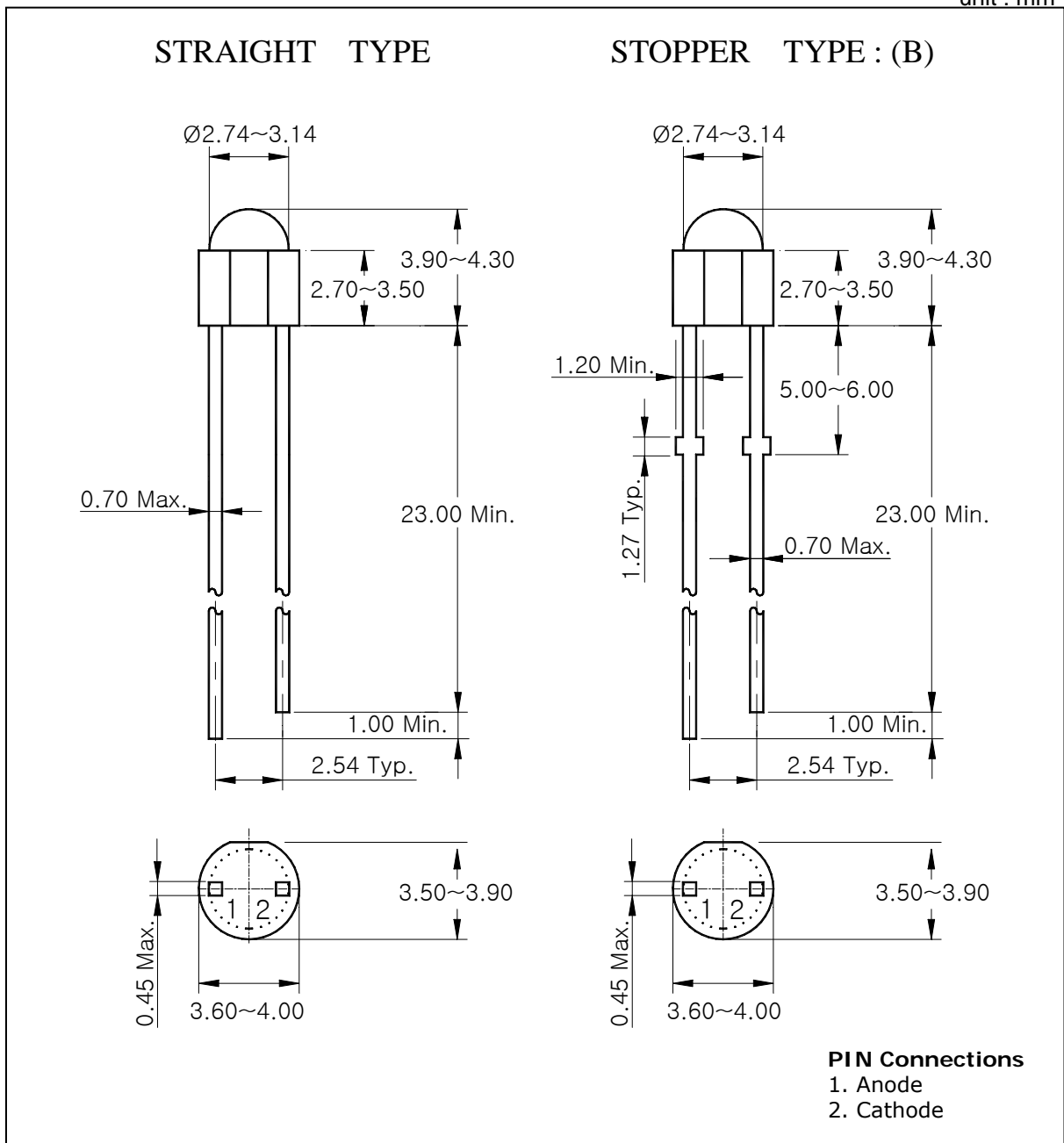

The contents of this data sheet are subject to change without advance notice for the purpose of improvement.  
When using this product, would you please refer to the latest specifications.

### 3. Absolute Maximum Ratings

(Ta=25°C)

| Characteristic              | Symbol    | Rating               | Unit |
|-----------------------------|-----------|----------------------|------|
| Power dissipation           | $P_D$     | 75                   | mW   |
| Forward current             | $I_F$     | 30                   | mA   |
| *1Peak forward current      | $I_{FP}$  | 50                   | mA   |
| Reverse voltage             | $V_R$     | 4                    | V    |
| Operating temperature range | $T_{opr}$ | -25~85               | °C   |
| Storage temperature range   | $T_{stg}$ | -30~100              | °C   |
| *2Soldering temperature     | $T_{sol}$ | 260°C for 10 seconds |      |

\*1.Duty ratio = 1/16, Pulse width = 0.1ms

\*2.Keep the distance more than 2.0mm from PCB to the bottom of LED package

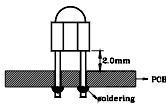

### 4. Electrical / Optical Characteristics

(Ta=25°C)

| Characteristic     | Symbol          | Test Condition     | Min | Typ      | Max | Unit |
|--------------------|-----------------|--------------------|-----|----------|-----|------|
| Forward voltage    | $V_F$           | $I_F= 20\text{mA}$ | -   | 2.1      | 2.5 | V    |
| Luminous Intensity | $I_V$           | $I_F= 20\text{mA}$ | 10  | -        | 43  | mcd  |
| Peak Wavelength    | $\lambda_P$     | $I_F= 20\text{mA}$ | -   | 585      | -   | nm   |
| Spectrum Bandwidth | $\Delta\lambda$ | $I_F= 20\text{mA}$ | -   | 30       | -   | nm   |
| Reverse Current    | $I_R$           | $V_R=4\text{V}$    | -   | -        | 10  | uA   |
| *3Half angle       | $\theta_{1/2}$  | $I_F= 20\text{mA}$ | -   | $\pm 45$ | -   | deg  |

\*4.  $\theta_{1/2}$  is the off-axis angle where the luminous intensity is 1/2 the peak intensity\*3. Luminous intensity maximum tolerance for each grade classification limit is  $\pm 18\%$ 

\*3. Luminous Intensity Classification

| G       | H       | I       |
|---------|---------|---------|
| 10 ~ 17 | 17 ~ 27 | 27 ~ 43 |

The contents of this data sheet are subject to change without advance notice for the purpose of improvement.  
When using this product, would you please refer to the latest specifications.

**5. Characteristic Diagrams**

**Fig. 1  $I_F - V_F$**

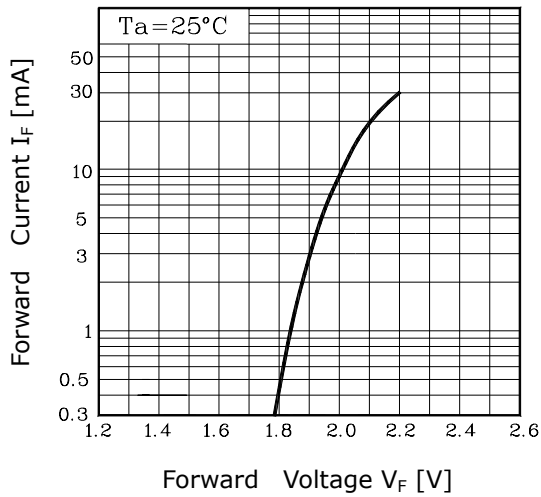

**Fig. 2  $I_V - I_F$**

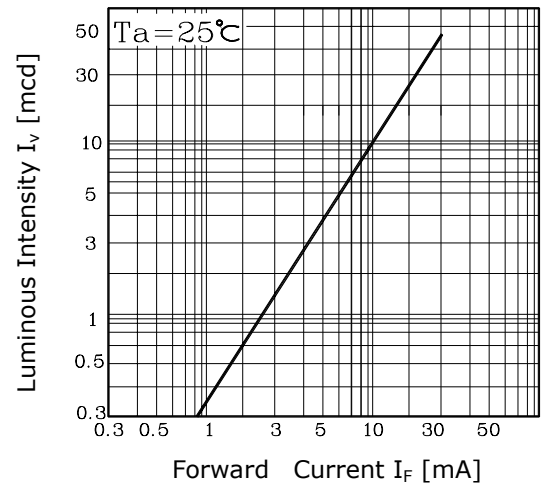

**Fig. 3  $I_F - T_a$**

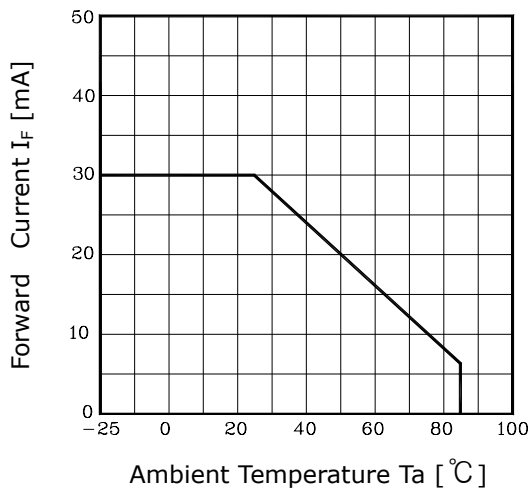

**Fig.4 Spectrum Distribution**

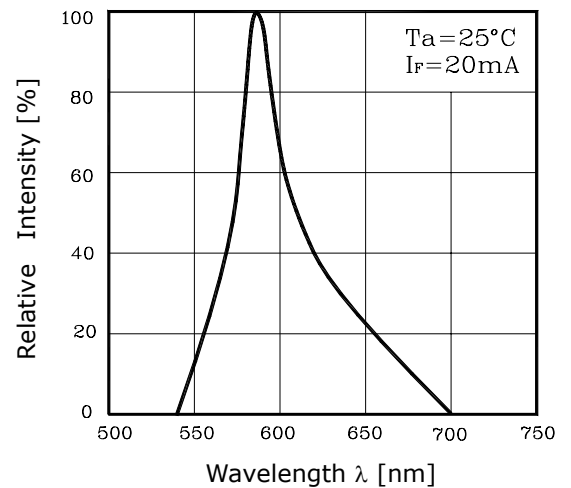

**Fig. 5 Radiation Diagram**

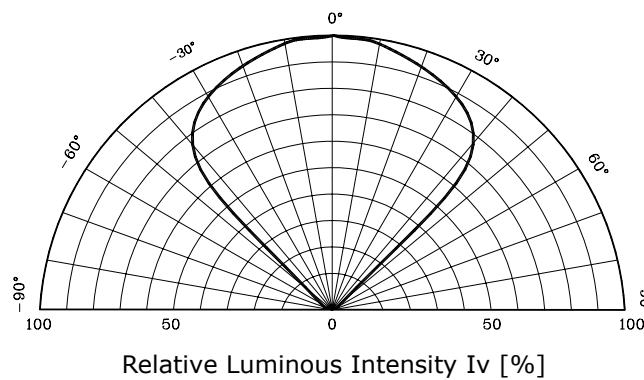

The contents of this data sheet are subject to change without advance notice for the purpose of improvement. When using this product, would you please refer to the latest specifications.