

FEATURES

- OUTPUT CURRENT UP TO 30A
- SMALL SIZE AND LOW PROFILE :
DOS30-05T:1.30 X 0.53 X 0.37 INCH , DOH30-05T:2.00 X 0.50 X 0.37 INCH
DOS30-12T:1.30 X 0.53 X 0.31 INCH , DOH30-12T:2.00 X 0.50 X 0.31 INCH
- HIGH EFFICIENCY UP TO 93%@5VIN, 3.3VOUT, FULL LOAD
- DOS(H)30-05T : 4.5VDC TO 5.5VDC INPUT, 0.8VDC TO 3.63VDC OUTPUT
DOS30-12T : 6.0VDC TO 14.0VDC INPUT, 0.8VDC TO 3.63VDC OUTPUT
DOH30-12T : 6.0VDC TO 14.0VDC INPUT, 0.8VDC TO 5.5VDC OUTPUT
- OUTPUT VOLTAGE PROGRAMMABLE VIA EXTERNAL RESISTOR
- SMD PACKAGE QUALIFIED FOR LEADFREE REFLOW SOLDER PROCESS ACCORDING IPC J-STD-020D
- FIXED SWITCHING FREQUENCY (300kHz)
- MONOTONIC START-UP INTO PRE-BIASED OUTPUT
- OUTPUT VOLTAGE SEQUENCING
- PARALLEL OPERATION WITH ACTIVE CURRENT SHARING
- SAFETY MEETS UL60950-1, EN60950-1, & IEC60950-1
- CE MARK MEETS 2006/95/EC, 2011/95/EC and 2004/108/EC
- COMPLIANT TO RoHS II & REACH

OPTIONS

POSITIVE LOGIC REMOTE ON/OFF, CURRENT SHARE, EXTRA GND PIN, LONG PINS

DESCRIPTION

DOS30-□□T (SMD type), DOH30□□T (SIP type) are non-isolated DC/DC converters that can deliver up to 30A of output current with full load efficiency of 93% at 5.0V input and 3.3V output.

APPLICATIONS

- Wireless Network
- Telecom/Datacom
- Industry Control System
- Distributed Power Architectures
- Semiconductor Equipment
- Microprocessor Power Applications

TECHNICAL SPECIFICATION All specifications are typical at nominal input, 3.3Vo, full load and 25°C otherwise

OUTPUT SPECIFICATIONS		
Output current	DOS30-05T	30A max.
	DOH30-05T	30A max.
	DOS30-12T	30A max.
	DOH30-12T	20A max.
		25A max.
Voltage accuracy	± 1.5%Vout(set)	
Minimum load	0%	
Line regulation	Vin=Vin(min.) to Vin(max.) at Full Load	± 0.1%Vout(set)
Load regulation	No Load to Full Load	± 0.4%Vout(set)
Ripple and noise (Note 2) 20MHz bandwidth	75mVp-p	
Temperature coefficient	±0.5%	
Dynamic load response (Note 2)	$\Delta I_{out}/t = 5A/\mu s$, Vin(nom)	Peak deviation
	Load change step (50% to 100% or 100% to 50% of Iout(max.))	Setting time (Vout<10%peak deviation)
		350mV
		25μs
Dynamic load response (Note 3)	$\Delta I_{out}/t = 5A/\mu s$, Vin(nom)	Peak deviation
	Load change step (50% to 100% or 100% to 50% of Iout(max.))	Setting time (Vout<10%peak deviation)
		250mV
		40μs
Output current limit	150%	
Output short-circuit current	Hiccup, Automatics recovery	
External load capacitance	ESR ≥ 1mΩ	2000μF,max.
	ESR ≥ 10mΩ	10000μF,max.
Output voltage overshoot-startup	Vin=Vin(min.) to Vin(max.) and F.L.	3%Vout(set), max.
Voltage adjustability (see fig.1) (Note 4)	DOS30-05T	0.8VDC ~ 3.63VDC
	DOH30-05T	0.8VDC ~ 3.63VDC
	DOS30-12T	0.8VDC ~ 3.63VDC
	DOH30-12T	0.8VDC ~ 5.5VDC
GENERAL SPECIFICATIONS		
Efficiency	See table	
Isolation voltage	None	
Switching frequency	300kHz±13%	
Safety meets	IEC60950-1, UL60950-1, & EN60950-1	
Dimensions	DOS30-05T	1.30X0.53X0.37 Inch (33.0X13.5X9.4 mm)
	DOS30-12T	1.30X0.53X0.31 Inch (33.0X13.5X7.8 mm)
	DOH30-05T	2.00X0.50X0.37 Inch (50.8X12.7X9.4 mm)
	DOH30-12T	2.00X0.50X0.31 Inch (50.8X12.7X7.8 mm)
Weight	SMD	6.0g(0.21oz)
	SIP	7.0g(0.25oz)
MTBF (Note 1)	MIL-HDBK-217F	1.258 x 10 ⁶ hrs

INPUT SPECIFICATIONS			
Input voltage range	DOS30-05T	Vin(nom) =5VDC	4.5 ~ 5.5VDC
	DOH30-05T	Vin,min.=Vout(set)+1.5VDC	
	DOS30-12T	Vin(nom) =12VDC	6.0 ~ 14.0VDC
	DOH30-12T	Vin,min.=Vout(set)+2.4VDC	
Input filter (Note 5)	C filter		
Input under-voltage lockout	Start-up voltage	4.4VDC	
	Shutdown voltage	4.3VDC	
Input reflected ripple current	5~20MHz, 1uH source impedance	100mA _{p-p}	

ENVIRONMENTAL SPECIFICATIONS

Operating ambient temperature	-40°C ~ +85°C(with derating)
Storage temperature range	-55°C ~ +125°C
Thermal shock	MIL-STD-810F
Vibration	MIL-STD-810F
Relative humidity(non-condensing)	5% to 95% RH
Lead-free reflow solder process	IPC J-STD-020D
Moisture sensitivity level(MSL)	IPC J-STD-033B Level 2a
Over temperature protection	125°C

FEATURE SPECIFICATIONS

Sequencing delay time (Note 6)	10ms, min.	
Tracking accuracy	V _{SEQ} - V _{out}	
	Power-up (2V/ms)	100mV
	Power-down (1V/ms)	200mV
Active load share (option) (Note 7)	Accuracy	10% Iout
	Number of units in parallel	5pcs,max.
Remote ON/OFF (Note 8)		
Negative logic(standard)	ON = Open or -0.3V < Vr < 1.2V	I _{IN} =200μA,max.
	OFF = 3.0V < Vr < Vin(max.)	I _{IN} =3.3mA,max.
Positive logic(option)	ON = Open or 3.0V < Vr < Vin(max.)	I _{IN} =200μA,max.
	OFF = -0.3V < Vr < 1.2V	I _{IN} =3.3mA,max.
Remote sense range	0.5V, max.	
Rise time	Time for Vout to rise from 10% to 90%of Vout(set)	10ms, max.
Turn-on delay time	Case 1 (Note 9)	2.5ms
	Case 2 (Note 10)	2.5ms

Model Name	Package	Input Voltage	Output Voltage	Output Current		No Load Current Vin(nom),3.3VDC	Efficiency Vin(nom),3.3VDC, Full Load
				Min. Load	Max. Load		
DOS30-05T	SMD	4.5 ~ 5.5VDC	0.8 ~ 3.63VDC	0A	30A	180mA	93%
DOH30-05T	SIP	Vin,min.=Vout(set)+1.5V	0.8 ~ 3.63VDC	0A	30A	180mA	93%
DOS30-12T	SMD	6.0 ~ 14.0VDC	0.8 ≤ Vout ≤ 2.75VDC	0A	30A	200mA	92%
			2.75 < Vout ≤ 3.63VDC		20A		
DOH30-12T	SIP	Vin,min.=Vout(set)+2.4V	0.8 ≤ Vout ≤ 2.75VDC	0A	30A	200mA	92%
			2.75 < Vout ≤ 5.5VDC		25A		

Note

1. MIL-HDBK-217F @Tc=70 °C, Full load.
2. External with C_{out} = 1μF ceramic//10μF tantalum capacitors.
3. External with C_{out} = 2×150μF polymer capacitors.
4. Output voltage programmable from 0.8V to 5.0V by connecting a single resistor (shown as R_{trim} in Table 1) between the TRIM and GND pins of the module. To calculate the value of the resistor R_{trim} for a particular output voltage V_{out}, use the following equation:

$$R_{trim} = \left[\frac{1200}{V_{out} - 0.80} - 100 \right] \Omega$$

5. To make sure the module is stable, input external capacitors is necessary that minimize input ripple voltage of the module.
6. Delay from Vin,min. to application of voltage on SEQ pin.
7. Selecting current share function that the regulations may not meet listed specification.
8. The On/Off signal is referenced to ground. The standard remote On/Off logic of the device is negative logic. Adding a device code suffix "-P" is option for positive logic of remote On/Off.
9. Case 1 :On/Off input is set to logic low (module on) and then input power is applied (delay from instant at which Vin=Vin(min.) until Vout=10% of Vout(set))
10. Case 2 :Input power is applied for at least one second and then the On/Off input is set to logic low (delay form instant at which Von/off=0.3V until Vout=10% of Vout(set))

CAUTION: This power module is not internally fused. An input line fuse must always be used.

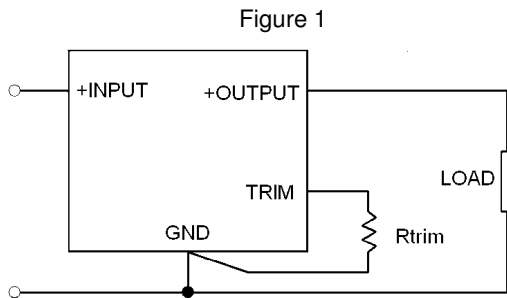

Figure 1

Table 1. Trim Table

Vout(set) (V)	Rtrim (Ω)
0.8	Open
1.2	2900
1.5	1614
1.8	1100
2.5	605
3.3	380
5.0	185

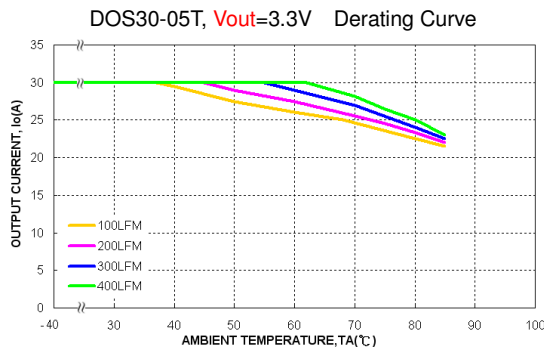
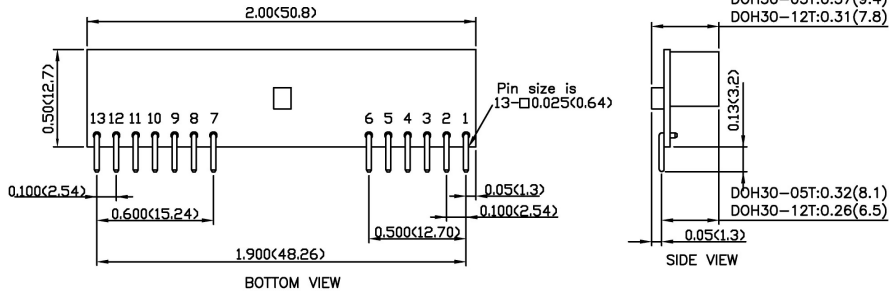

Table 2. Device Options

Option	Suffix
Remote On/Off Positive Logic	-P
Current Share	-S
Extra GND pin 2 extra GND pins only for SMD TYPE	-E
Long Pins 5.08mm±0.25mm only for SIP TYPE	-L

MECHANICAL DRAWING :

SIP TYPE



PIN CONNECTION	
PIN	DEFINE
1	+OUTPUT
2	+OUTPUT
3	+SENSE
4	+OUTPUT
5	GND
6	GND
7	SHARE(option)
8	GND
9	+ INPUT
10	+ INPUT
11	SEQ
12	TRIM
13	CTRL

SMD TYPE

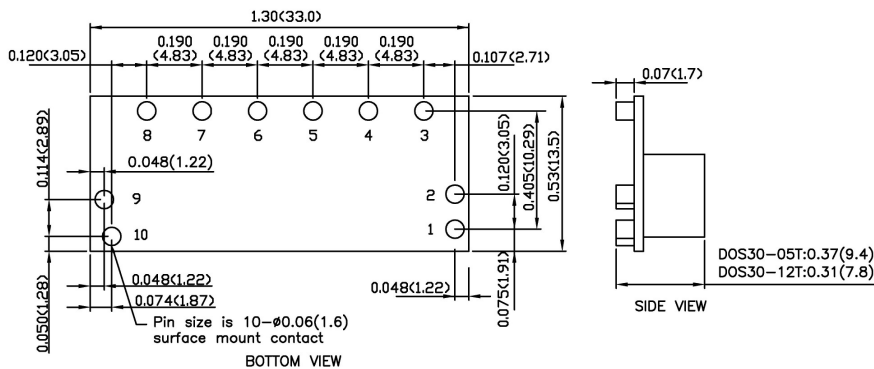

PIN CONNECTION	
PIN	DEFINE
1	CTRL
2	GND(option)
3	SHARE(option)
4	+SENSE
5	TRIM
6	+OUTPUT
7	GND
8	SEQ
9	GND(option)
10	+ INPUT

- All dimensions in Inch (mm)
Tolerance: X.XX±0.02 (X.X±0.5)
X.XXX±0.01 (X.XX±0.25)
- Pin pitch tolerance ±0.01 (0.25)
- Pin dimension tolerance ±0.004 (0.1)