

MATERIALS	
TNC BODY	PASSIVATED STAINLESS STEEL
CONTACT	GOLD PLATED
INSULATOR	PTFE
COUPLING MECHANISM	STAINLESS STEEL

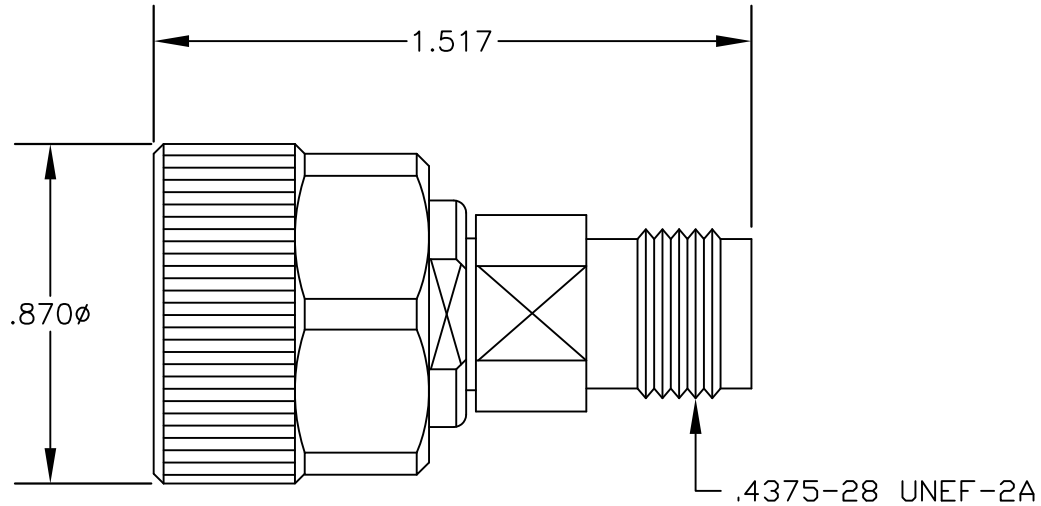

SPECIFICATIONS

FREQUENCY RANGE; DC TO 18 GHz
 MAX VSWR 1.15:1



PASTERNACK ENTERPRISES, INC.
 P.O BOX 16759, IRVINE, CA 92623
 PHONE (949) 261-1920 FAX (949) 261-7451
 WEB ADDRESS: www.pasternack.com
 E-MAIL ADDRESS: sales@pasternack.com
COAXIAL & FIBER OPTICS

DWG TITLE		DES. 7mm TO TNC FEMALE, PRECISION ADAPTER			
PE9218					
SIZE A	FSCM NO. 53919	CAD FILE 010903	SCALE N/A	127	

NOTES:
 1. UNLESS OTHERWISE SPECIFIED ALL DIMENSIONS ARE NOMINAL.
 2. ALL SPECIFICATIONS ARE SUBJECT TO CHANGE WITHOUT NOTICE AT ANY TIME.