

EnerChip™ CC Backup Power for Micro Crystal RV-2123 RTC

Introduction

Cymbet EnerChips are solid state rechargeable batteries having distinguishing characteristics compared to conventional rechargeable batteries. EnerChips have a high charge/discharge cycle life; low self-discharge; simple voltage controlled charging; flat discharge voltage profile; have no flammable solvents to leak or catch fire; are solder reflow tolerant; and are offered in low profile surface mount packages.

The EnerChip CC is a surface mount package containing a rechargeable solid state battery - the EnerChip - with integrated battery management that includes charge control, discharge cutoff circuitry, and a battery switchover (i.e., supply supervisory) function. EnerChip storage (discharge) capacity varies by product. EnerChips are used in applications requiring backup, bridging, or transition power to maintain real-time clock (RTC) operation or SRAM data retention in the event of main power interruption; wireless sensing as the main power source when energy can be harvested from the ambient power and used to constantly trickle charge the EnerChip; and as a power source to perform housekeeping for microcontrollers (MCUs) and peripherals when main power is interrupted, to ensure an orderly shutdown or transition to low power modes.

Many applications demand ultra low power consumption from the various system components, particularly when system power is derived from primary or rechargeable batteries. Moreover, in systems utilizing RTCs it is essential that when main power is interrupted, the standby power of the RTC be exceedingly low in order to achieve maximum run time from the backup power source. A commonly used RTC is the Micro Crystal RV-2123. Because the device has very low operating current in backup mode - typically 130nA at 3V - a miniature EnerChip device with integrated power management can provide up to several days of backup power to the RTC when main power is interrupted. This Application Note describes use of the EnerChip CC - solid state energy storage integrated with battery management in a single package - as a backup power source for the RV-2123 RTC.

A typical application circuit is shown in Figure 1. Main power is fed to the CBC31xx, which in turn powers the RV-2123. When the supply voltage drops below a specific threshold as detected by the CBC31xx, the EnerChip solid state battery embedded in the EnerChip CC delivers power to the RTC through the CBC31xx VOUT pin.

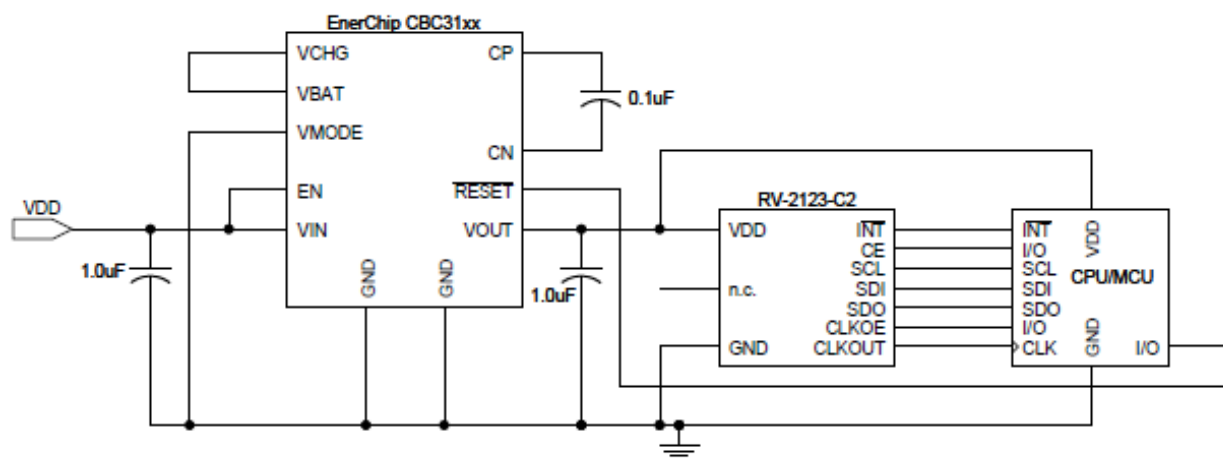

Figure 1. Typical Application Circuit Using the EnerChip CC and Micro Crystal RV-2123 Real-Time Clock.

AN-1045: EnerChip™ CC Backup Power for RV-2123 RTC

Circuit Description and Operation

Under normal operation, the RTC derives its power from the main system supply, which might be a large coin cell, prismatic cell, cylindrical batteries, or indirectly from wall power through a voltage regulator. Because the EnerChip has very low self-discharge, it needs to be charged only after it has been used in the performance of its duty as a backup power source or on a very infrequent basis to keep it fully charged when not being used. To maintain a charge of 90% or greater on the EnerChip when it has not been used as a backup power source for prolonged periods, the EnerChip needs no more than one hour of charging time per month. Such a low charging duty cycle would present a negligible parasitic load to the main power source, as the EnerChip charges quickly and its charging current decays to just tens of nanoamperes when fully charged. The EnerChip CC controls the EnerChip charging function internally.

When main power is interrupted - as during line power outages or when the main battery is removed for recharging or replacement, the backup power source provides enough energy to maintain operation of the real-time clock. In applications where the RTC is connected to a CPU or MCU, it might be necessary to connect the CBC31xx RESET/ line to the gate of an n-channel FET placed between the CPU/MCU ground pin and system ground. This configuration ensures that no ESD I/O structures in the CPU/MCU are biased with the interface bus lines, resulting in a parasitic drain on the EnerChip.

The EnerChip CC is a surface mount device that contains a rechargeable battery with integrated battery management that performs the charge control, discharge control, threshold voltage detection, and supply supervisory functions all in one low profile package. It operates over the range of 2.5V to 5.5V and the switchover threshold voltage is adjustable. A block diagram of the EnerChip CC is shown in Figure 2.

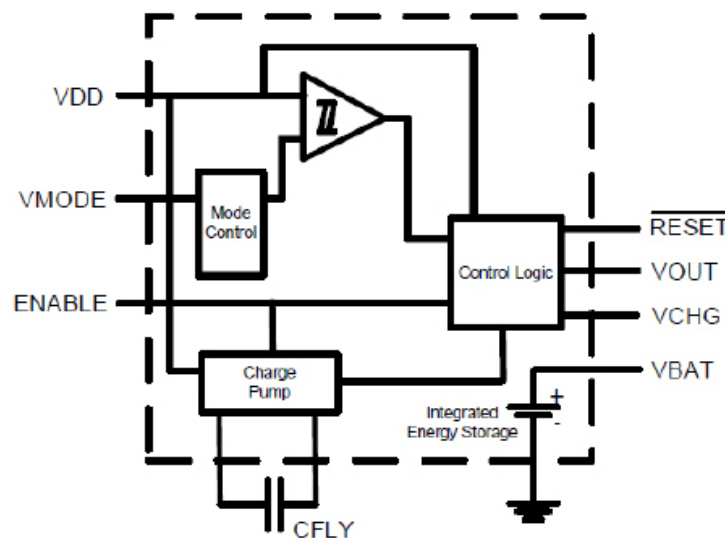

Figure 2. Block diagram of the EnerChip CC Thin Film Battery with Integrated Battery Management

EnerChip CC includes the following functional elements:

- Internal charge control circuit that converts a wide range of input voltages to a tightly regulated battery charging voltage;
- Battery cutoff circuit that disconnects the load from the embedded EnerChip when the discharge voltage reaches a preset limit;
- Output pin (RESET/) that can be used to drive an interrupt line on an MCU to indicate that the system is operating in battery-backed mode;
- A voltage detection circuit allowing a user-selectable threshold trip voltage;
- A control line that enables and disables the internal charge pump that can be controlled externally to reduce power consumption when the internal EnerChip does not need to be charged.

AN-1045: EnerChip™ CC Backup Power for RV-2123 RTC

All of these features have been combined to create a backup power solution that eliminates the need for a dedicated supply supervisory circuit, battery holder or socket, separate battery management circuitry, and a conventional power source such as a coin cell or supercapacitor. The result is a compact, single-chip solution to backup and bridging power. The power source - the EnerChip - is a component class, rechargeable solid state battery that has no organic solvents or harmful chemicals that accompany coin cells and supercapacitors.

Given the low operating current of many RTCs, the EnerChip CC can provide several hours to several days of backup time. Backup time is calculated based on the typical RTC current and the EnerChip CC battery cutoff circuit current of 30nA (typical). The following table illustrates the amount of backup time afforded by the EnerChip CC devices - CBC3105, CBC3112, and CBC3150 - when connected to the Micro Crystal RV-2123 RTC.

<i>EnerChip CC</i>	<i>DFN Package Size (mm)</i>	<i>Backup Run Time (days)</i>
CBC3105	4 x 5 x 0.9	1.5
CBC3112	7 x 7 x 0.9	3.3
CBC3150	9 x 9 x 0.9	14

Given that the vast majority power interruptions - whether due to grid power outages in wall-powered systems or in mobile devices during main battery recharging and replacement - are less than one day, either EnerChip CC device can be used in most applications. Once the minimum backup run time specification is defined, device selection can be made accordingly and in conjunction with other considerations such as package footprint. The EnerChip CC is also configured to allow additional surface mount EnerChips to be connected to increase backup run time.

In cases where an MCU must also be maintained in a low power state (as opposed to completely disconnected from the circuit) during battery-backed operation, the MCU sleep current must be factored into the backup run time equation. To maintain favorable backup run time, the designer can choose from a variety of MCUs, some having sleep currents as low as 20nA. When using MCUs with such exceptionally low sleep currents, the backup run time is not reduced significantly. During operation, the MCU can also be programmed to drive the EnerChip CC ENABLE line low when EnerChip battery charging is not required. Doing so will reduce the overhead current associated with operating the charge pump internal to the EnerChip CC.

Conclusion

Many systems utilizing RTCs require backup power supply backup in the event of main power interruption. Conventional backup power sources are primary coin cells, rechargeable coin cells, and supercapacitors. Traditional backup power sources have long charge times, high self-discharge, require relatively high steady state parasitic charging current, and often require external components for charge control and discharge cutoff. The EnerChip - with its low self-discharge, low parasitic current draw when charged, and fast recharge time - is a superior solution to supercapacitors and coin cell batteries in backup power applications. When implemented in systems using real-time clocks, the EnerChip CC delivers a robust backup power source with high cycle life and integrated battery management in a low profile, compact surface mount package.