

FEATURES

- PEAK PULSE POWER= 400 W @ 1ms
- STAND-OFF VOLTAGE RANGE :
From 5V8 to 376 V
- UNI AND BIDIRECTIONAL TYPES
- LOW CLAMPING FACTOR
- FAST RESPONSE TIME
- UL RECOGNIZED

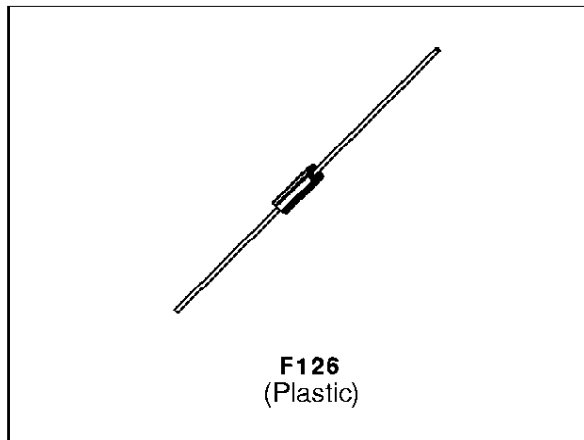

DESCRIPTION

Transil diodes provide high overvoltage protection by clamping action. Their instantaneous response to transients makes them particularly suited to protect voltage sensitive devices such as MOS Technology and low voltage supplied IC's.

ABSOLUTE MAXIMUM RATINGS ($T_{amb} = 25^{\circ}\text{C}$)

Symbol	Parameter	Value	Unit
P_p	Peak pulse power dissipation	400	W
P	Power dissipation on infinite heatsink	$T_{lead} = 75^{\circ}\text{C}$ 1.7	W
T_{stg} T_j	Storage temperature range Maximum junction temperature	- 65 to + 175 175	$^{\circ}\text{C}$ $^{\circ}\text{C}$
T_L	Maximum lead temperature for soldering during 10 s.	230	$^{\circ}\text{C}$

THERMAL RESISTANCES

Symbol	Parameter	Value	Unit
$R_{th(j-l)}$	Junction to leads on infinite heatsink	60	$^{\circ}\text{C/W}$
$R_{th(j-a)}$	Junction to ambient on printed circuit. $L_{lead} = 10\text{ mm}$	100	$^{\circ}\text{C/W}$

BZW04-xx

ELECTRICAL CHARACTERISTICS

($T_{amb} = 25^{\circ}\text{C}$)

Symbol	Parameter
V_{RM}	Stand-off voltage
V_{BR}	Breakdown voltage
V_{CL}	Clamping voltage
I_{RM}	Leakage current @ V_{RM}
I_{PP}	Peak pulse current
αT	Voltage temperature coefficient
V_F	Forward voltage drop $V_F < 3.5\text{V} @ I_F = 25\text{A}$

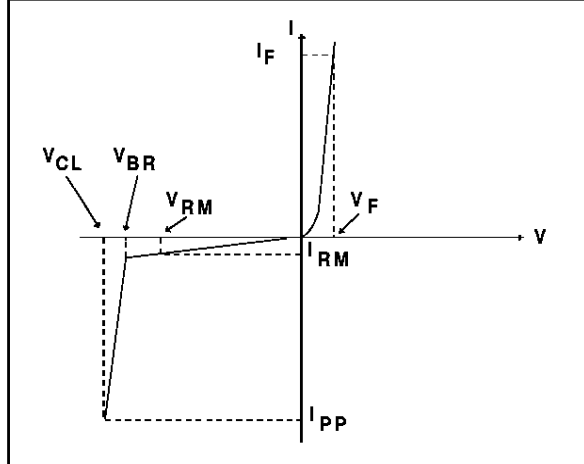

Types		$I_{RM} @ V_{RM}$ max		$V_{BR} @ I_R$ min nom max				$V_{CL} @ I_{PP}$ max		$V_{CL} @ I_{PP}$ max		αT max	C typ
Unidirectional	Bidirectional	μA	V	V	V	V	mA	V	A	V	A	note3	note4
				note2				10/1000 μs		8/20 μs		note3	note4
												$10^{-4}/^{\circ}\text{C}$	pF
BZW04P5V8	BZW04P5V8B	1000	5.8	6.45	6.8	7.48	10	10.5	38	13.4	174	5.7	3500
BZW04-5V8	BZW04-5V8B	1000	5.8	6.45	6.8	7.14	10	10.5	38	13.4	174	5.7	3500
BZW04P6V4	BZW04P6V4B	500	6.4	7.13	7.5	8.25	10	11.3	35.4	14.5	160	6.1	3100
BZW04-6V4	BZW04-6V4B	500	6.4	7.13	7.5	7.88	10	11.3	35.4	14.5	160	6.1	3100
BZW04P7V0	BZW04P7V0B	200	7.02	7.79	8.2	9.02	10	12.1	33	15.5	148	6.5	2700
BZW04-7V0	BZW04-7V0B	200	7.02	7.79	8.2	8.61	10	12.1	33	15.5	148	6.5	2700
BZW04P7V8	BZW04P7V8B	50	7.78	8.65	9.1	10	1	13.4	30	17.1	134	6.8	2300
BZW04-7V8	BZW04-7V8B	50	7.78	8.65	9.1	9.55	1	13.4	30	17.1	134	6.8	2300
BZW04P8V5	BZW04P8V5B	10	8.55	9.5	10	11	1	14.5	27.6	18.6	124	7.3	2000
BZW04-8V5	BZW04-8V5B	10	8.55	9.5	10	10.5	1	14.5	27.6	18.6	124	7.3	2000
BZW04P9V4	BZW04P9V4B	5	9.4	10.5	11	12.1	1	15.6	25.7	20.3	113	7.5	1750
BZW04-9V4	BZW04-9V4B	5	9.4	10.5	11	11.6	1	15.6	25.7	20.3	113	7.5	1750
BZW04P10	BZW04-9V4B	5	10.2	11.4	12	13.2	1	16.7	24	21.7	106	7.8	1550
BZW04-10	BZW04-10B	5	10.2	11.4	12	12.6	1	16.7	24	21.7	106	7.8	1550
BZW04P11	BZW04P11B	5	11.1	12.4	13	14.3	1	18.2	22	23.6	97	8.1	1450
BZW04-11	BZW04-11B	5	11.1	12.4	13	13.7	1	18.2	22	23.6	97	8.1	1450
BZW04P13	BZW04P13B	5	12.8	14.3	15	16.5	1	21.2	19	27.2	85	8.4	1200
BZW04-13	BZW04-13B	5	12.8	14.3	15	15.8	1	21.2	19	27.2	85	8.4	1200
BZW04P14	BZW04P14B	5	13.6	15.2	16	17.6	1	22.5	17.8	28.9	80	8.6	1100
BZW04-14	BZW04-14B	5	13.6	15.2	16	16.8	1	22.5	17.8	28.9	80	8.6	1100
BZW04P15	BZW04P15B	5	15.3	17.1	18	19.8	1	25.2	16	32.5	71	8.8	975
BZW04-15	BZW04-15B	5	15.3	17.1	18	18.9	1	25.2	16	32.5	71	8.8	975
BZW04P17	BZW04P17B	5	17.1	19	20	22	1	27.7	14.5	36.1	64	9.0	850
BZW04-17	BZW04-17B	5	17.1	19	20	21	1	27.7	14.5	36.1	64	9.0	850
BZW04P19	BZW04P19B	5	18.8	20.9	22	24.2	1	30.6	13	39.3	59	9.2	800
BZW04-19	BZW04-19B	5	18.8	20.9	22	23.1	1	30.6	13	39.3	59	9.2	800

Types		I _{RM} @ V _{RM}		V _{BR} @ I _R				V _{CL} @ I _{PP}		V _{CL} @ I _{PP}		αT max note3	C typ note4
				min	nom	max	max	max	max				
Unidirectional	Bidirectional	μA	V	V	V	V	mA	V	A	V	A	10 ⁻⁴ °C	pF
BZW04P20	BZW04P20B	5	20.5	22.8	24	26.4	1	33.2	12	42.8	54	9.4	725
BZW04-20	BZW04-20B	5	20.5	22.8	24	25.2	1	33.2	12	42.8	54	9.4	725
BZW04P23	BZW04P23B	5	23.1	25.7	27	29.7	1	37.5	10.7	48.3	48	9.6	625
BZW04-23	BZW04-23B	5	23.1	25.7	27	28.4	1	37.5	10.7	48.3	48	9.6	625
BZW04P26	BZW04P26B	5	25.6	28.5	30	33	1	41.5	9.6	53.5	43	9.7	575
BZW04-26	BZW04-26B	5	25.6	28.5	30	31.5	1	41.5	9.6	53.5	43	9.7	575
BZW04P28	BZW04P28B	5	28.2	31.4	33	36.3	1	45.7	8.8	59.0	39	9.8	510
BZW04-28	BZW04-28B	5	28.2	31.4	33	34.7	1	45.7	8.8	59.0	39	9.8	510
BZW04P31	BZW04P31B	5	30.8	34.2	36	39.6	1	49.9	8	64.3	36	9.9	480
BZW04-31	BZW04-31B	5	30.8	34.2	36	37.8	1	49.9	8	64.3	36	9.9	480
BZW04P33	BZW04P33B	5	33.3	37.1	39	42.9	1	53.9	7.4	69.7	33	10.0	450
BZW04-33	BZW04-33B	5	33.3	37.1	39	41.0	1	53.9	7.4	69.7	33	10.0	450
BZW04P37	BZW04P37B	5	36.8	40.9	43	47.3	1	59.3	6.7	76.8	30	10.1	400
BZW04-37	BZW04-37B	5	36.8	40.9	43	45.2	1	59.3	6.7	76.8	30	10.1	400
BZW04P40	BZW04P40B	5	40.2	44.7	47	51.7	1	64.8	6.2	84	27	10.1	370
BZW04-40	BZW04-40B	5	40.2	44.7	47	49.4	1	64.8	6.2	84	27	10.1	370
BZW04P44	BZW04P44B	5	43.6	48.5	51	56.1	1	70.1	5.7	91	25	10.2	350
BZW04-44	BZW04-44B	5	43.6	48.5	51	53.6	1	70.1	5.7	91	25	10.2	350
BZW04P48	BZW04P48B	5	47.8	53.2	56	61.6	1	77	5.2	100	23	10.3	320
BZW04-48	BZW04-48B	5	47.8	53.2	56	58.8	1	77	5.2	100	23	10.3	320
BZW04P53	BZW04P53B	5	53.0	58.9	62	68.2	1	85	4.7	111	21	10.4	290
BZW04-53	BZW04-53B	5	53.0	58.9	62	65.1	1	85	4.7	111	21	10.4	290
BZW04P58	BZW04P58B	5	58.1	64.6	68	74.8	1	92	4.3	121	19	10.4	270
BZW04-58	BZW04-58B	5	58.1	64.6	68	71.4	1	92	4.3	121	19	10.4	270
BZW04P64	BZW04P64B	5	64.1	71.3	75	82.5	1	103	3.9	134	17	10.5	250
BZW04-64	BZW04-64B	5	64.1	71.3	75	78.8	1	103	3.9	134	17	10.5	250
BZW04P70	BZW04P70B	5	70.1	77.9	82	90.2	1	113	3.5	146	16	10.5	230
BZW04-70	BZW04-70B	5	70.1	77.9	82	86.1	1	113	3.5	146	16	10.5	230
BZW04P78	BZW04P78B	5	77.8	86.5	91	100	1	125	3.2	162	14	10.6	210
BZW04-78	BZW04-78B	5	77.8	86.5	91	95.5	1	125	3.2	162	14	10.6	210
BZW04P85	BZW04P85B	5	85.5	95.0	100	110	1	137	2.9	178	13	10.6	200
BZW04-85	BZW04-85B	5	85.5	95.0	100	105	1	137	2.9	178	13	10.6	200
BZW04P94	BZW04P94B	5	94.0	105	110	121	1	152	2.6	195	12	10.7	185
BZW04-94	BZW04-94B	5	94.0	105	110	116	1	152	2.6	195	12	10.7	185
BZW04P102	BZW04P102B	5	102	114	120	132	1	165	2.4	212	11	10.7	170
BZW04-102	BZW04-102B	5	102	114	120	126	1	165	2.4	212	11	10.7	170
BZW04P111	BZW04P111B	5	111	124	130	143	1	179	2.2	230	10	10.7	165
BZW04-111	BZW04-111B	5	111	124	130	137	1	179	2.2	230	10	10.7	165

BZW04-xx

TYPES		I_{RM} @ V_{RM} max		V_{BR} @ I_R min nom max note2				V_{CL} @ I_{PP} max 10/1000 μ s		V_{CL} @ I_{PP} max 8/20 μ s		αT max note3	C typ note4
Unidirectional	Unidirectional	μ A	V	V	V	V	mA	V	A	V	A	10 ⁻⁴ °C	pF
BZW04P128	BZW04P128B	5	128	143	150	165	1	207	2.0	265	9	10.8	145
BZW04-128	BZW04-128B	5	128	143	150	158	1	207	2.0	265	9	10.8	145
BZW04P136	BZW04P136B	5	136	152	160	176	1	219	1.8	282	8	10.8	140
BZW04-136	BZW04-136B	5	136	152	160	168	1	219	1.8	282	8	10.8	140
BZW04P145	BZW04P145B	5	145	161	170	187	1	234	1.7	301	7.5	10.8	135
BZW04-145	BZW04-145B	5	145	161	170	179	1	234	1.7	301	7.5	10.8	135
BZW04P154	BZW04P154B	5	154	171	180	198	1	246	1.6	317	7	10.8	125
BZW04-154	BZW04-154B	5	154	171	180	189	1	246	1.6	317	7	10.8	125
BZW04P171	BZW04P171B	5	171	190	200	220	1	274	1.5	353	6.5	10.8	120
BZW04-171	BZW04-171B	5	171	190	200	210	1	274	1.5	353	6.5	10.8	120
BZW04P188	BZW04P188B	5	188	209	220	242	1	328	1.4	388	6	10.8	110
BZW04-188	BZW04-188B	5	188	209	220	231	1	328	1.4	388	6	10.8	110
BZW04P213	BZW04P213B	5	213	237	250	275	1	344	1.5	442	5.2	11	100
BZW04-213	BZW04-213B	5	231	237	250	263	1	344	1.5	442	5.2	11	100
BZW04P239	BZW04P239B	5	239	266	280	308	1	384	1.5	494	4.6	11	95
BZW04-239	BZW04-239B	5	239	266	280	294	1	384	1.5	494	4.6	11	95
BZW04P256	BZW04P256B	5	256	285	300	330	1	414	1.2	529	4.3	11	90
BZW04-256	BZW04-256B	5	256	285	300	315	1	414	1.2	529	4.3	11	90
BZW04P273	BZW04P273B	5	273	304	320	352	1	438	1.2	564	4	11	85
BZW04-273	BZW04-273B	5	273	304	320	336	1	438	1.2	564	4	11	85
BZW04P299	BZW04P299B	5	299	332	350	385	1	482	0.9	618	3.7	11	80
BZW04-299	BZW04-299B	5	299	332	350	368	1	482	0.9	618	3.7	11	80
BZW04P342	BZW04P342B	5	342	380	400	440	1	548	0.9	706	3.2	11	75
BZW04-342	BZW04-342B	5	342	380	400	420	1	548	0.9	706	3.2	11	75
BZW04P376	BZW04P376B	5	376	418	440	484	1	603	0.8	776	3	11	70
BZW04-376	BZW04-376B	5	376	418	440	462	1	603	0.8	776	3	11	70

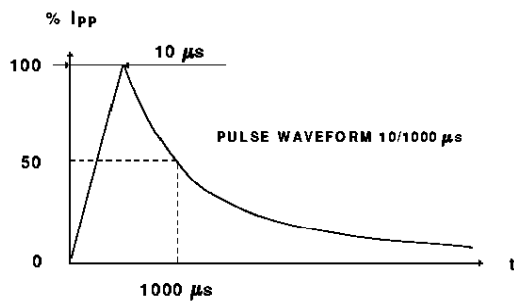

- Note 1 :** For surges greater than the maximum values, the diode will present a short-circuit Anode - Cathode
- Note 2 :** Pulse test: $t_p < 50$ ms.
- Note 3 :** $\Delta V_{BR} = \alpha T \cdot (T_{amb} - 25) \cdot V_{BR}(25^\circ C)$
- Note 4 :** $V_R = 0$ V, $F = 1$ MHz. For bidirectional types, capacitance value is divided by 2.

Fig. 1: Power dissipation derating versus ambient temperature

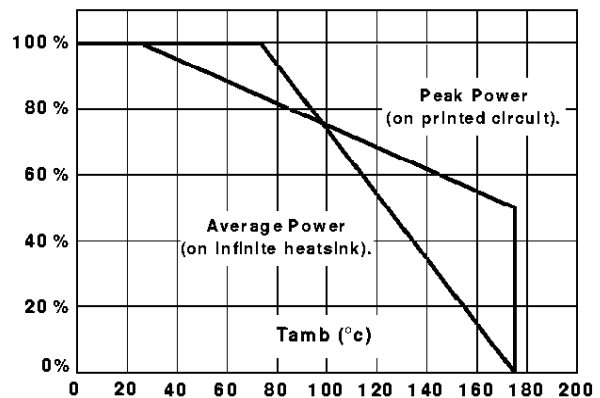

Fig. 2 : Peak pulse power versus exponential pulse duration.

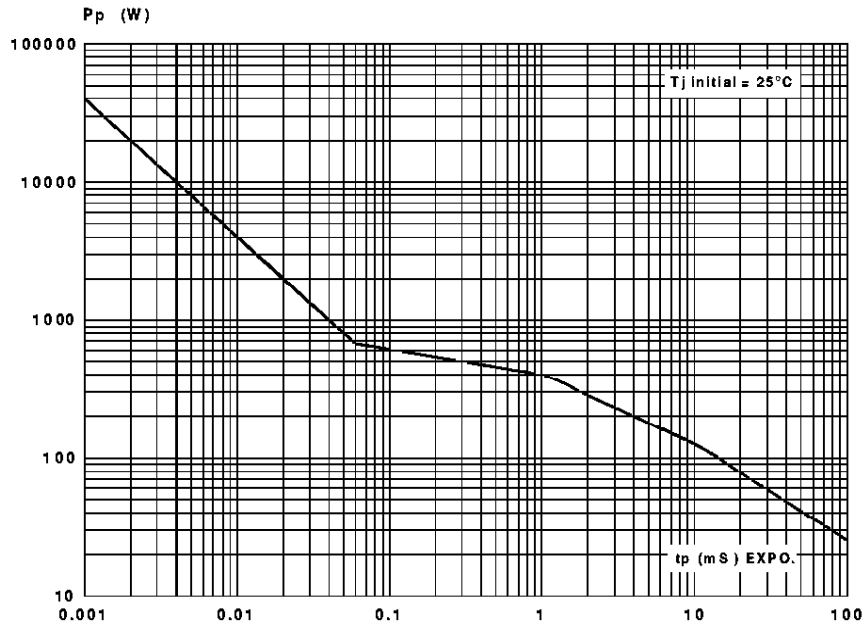
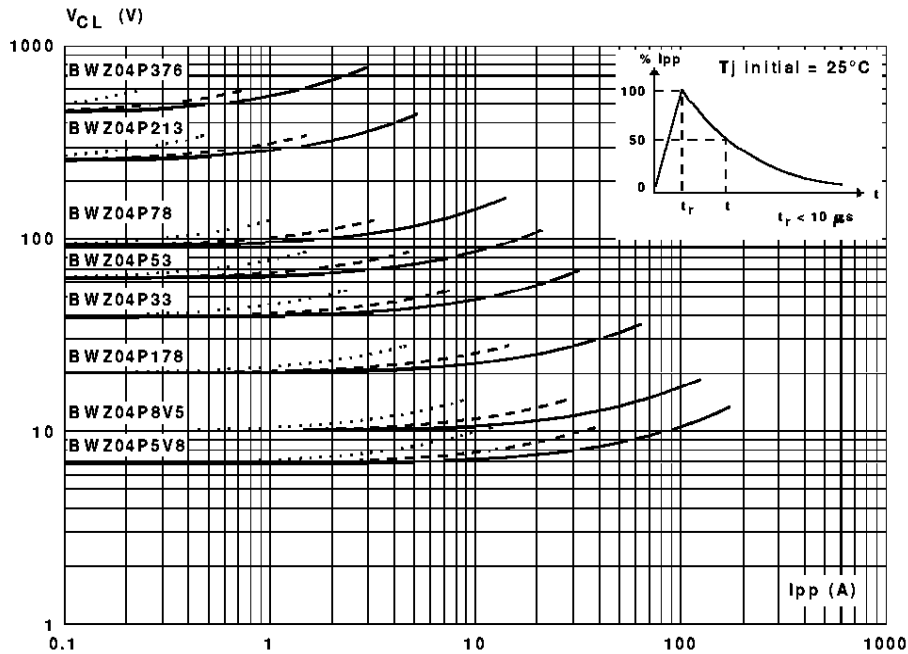

Fig. 3 : Clamping voltage versus peak pulse current.
 Exponential waveform $t_p = 20 \mu s$ ———
 $t_p = 1 ms$ - - - - -
 $t_p = 10 ms$
 $t_r < 10 \mu s$



Note : The curves of the figure 3 are specified for a junction temperature of 25 °C before surge.
 The given results may be extrapolated for other junction temperatures by using the following formula :
 $\Delta V_{BR} = \alpha T \cdot (T_{amb} - 25) \cdot V_{BR} (25^\circ C)$.
 For intermediate voltages, extrapolate the given results.

Fig. 4a : Capacitance versus reverse applied voltage for unidirectional types (typical values).

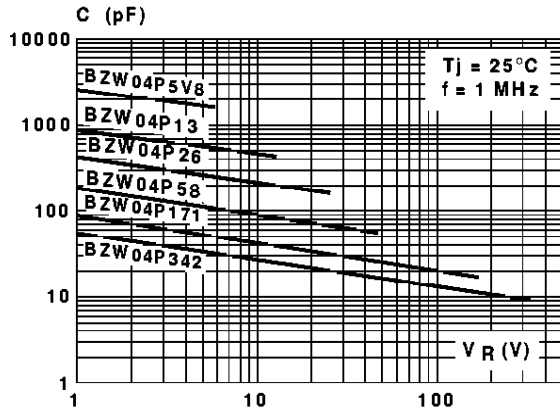

Fig. 4b : Capacitance versus reverse applied voltage for bidirectional types (typical values).

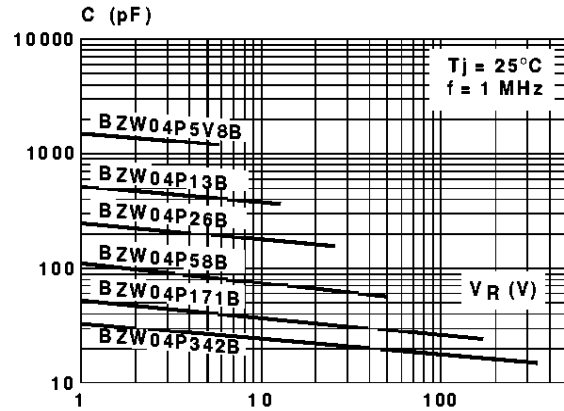

Fig. 5 : Peak forward voltage drop versus peak forward current (typical values for unidirectional types).

Note : For units with $V_{BR} > 200$ V V_F is twice than shown.

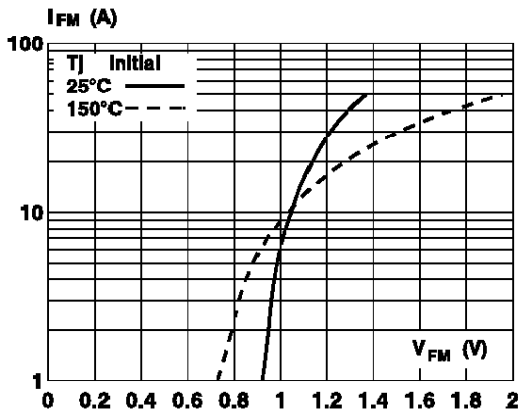
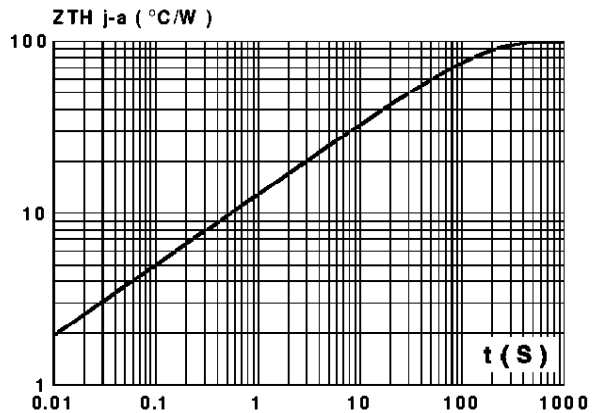
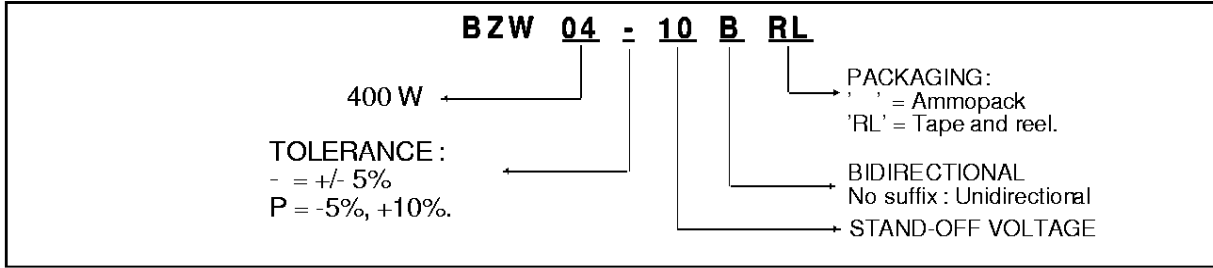

Fig. 6 : Transient thermal impedance junction-ambient versus pulse duration. For a mounting on PC Board with $L_{lead} = 10$ mm.



ORDER CODE



MARKING : Logo, Date Code, Type Code, Cathode Band (for unidirectional types only).

PACKAGE MECHANICAL DATA
F126 (Plastic)

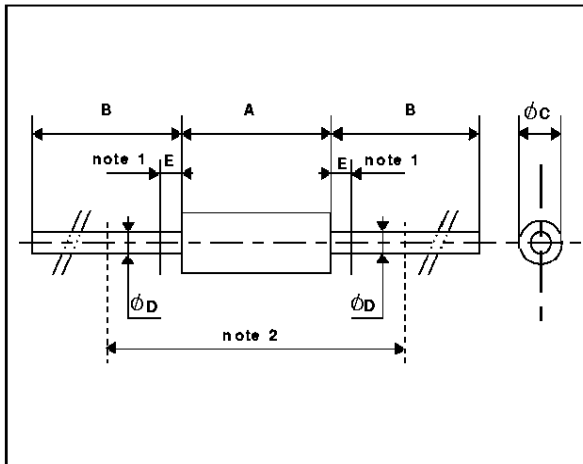

Weight = 0.4 g.

Packaging : standard packaging is in tape and reel.

REF.	DIMENSIONS				NOTES
	Millimeters		Inches		
	Min.	Max.	Min.	Max.	
A	6.05	6.35	0.238	0.250	1 - The lead diameter ϕ D is not controlled over zone E 2 - The minimum axial length within which the device may be placed with its leads bent at right angles is 0.59"(15 mm)
B	26		1.024		
ϕ C	2.95	3.05	0.116	0.120	
ϕ D	0.76	0.86	0.029	0.034	
E		1.27		0.050	

Information furnished is believed to be accurate and reliable. However, SGS-THOMSON Microelectronics assumes no responsibility for the consequences of use of such information nor for any infringement of patents or other rights of third parties which may result from its use. No license is granted by implication or otherwise under any patent or patent rights of SGS-THOMSON Microelectronics. Specifications mentioned in this publication are subject to change without notice. This publication supersedes and replaces all information previously supplied. SGS-THOMSON Microelectronics products are not authorized for use as critical components in life support devices or systems without express written approval of SGS-THOMSON Microelectronics.

© 1995 SGS-THOMSON Microelectronics - Printed in Italy - All rights reserved.

SGS-THOMSON Microelectronics GROUP OF COMPANIES

Australia - Brazil - France - Germany - Hong Kong - Italy - Japan - Korea - Malaysia - Malta - Morocco - The Netherlands
Singapore - Spain - Sweden - Switzerland - Taiwan - Thailand - United Kingdom - U.S.A.