



ISP1763A

Hi-Speed USB OTG controller

Rev. 04 — October 14, 2013

Product data sheet

1. General description

The ISP1763A is a single-chip Hi-Speed Universal Serial Bus (USB) On-The-Go (OTG) controller integrated with the advanced slave host controller and the ISP1582 peripheral controller.

The Hi-Speed USB host controller and peripheral controller comply with *Universal Serial Bus Specification Rev. 2.0* and support data transfer speeds of up to 480 Mbit/s. The Enhanced Host Controller Interface (EHCI) core implemented in the host controller is adapted from *Enhanced Host Controller Interface Specification for Universal Serial Bus Rev. 1.0*. The OTG controller is compliant with *On-The-Go Supplement to the USB Specification Rev. 1.3*.

The ISP1763A has two USB ports. Port 1 can be configured to function as a downstream port, an upstream port, or as an OTG port; port 2 is always configured as a downstream port. Port 2 supports Session Request Protocol (SRP) detection from the B-device. The OTG port supports Host Negotiation Protocol (HNP) and SRP as specified in *On-The-Go Supplement to the USB Specification Rev. 1.3*.

The ISP1763A support multiple bus interfaces with 8-bit or 16-bit bus. The ISP1763A can interface to processors with digital I/O voltages of 1.8 V or 3.3 V.

2. Features

- Compliant with:
 - ◆ *Universal Serial Bus Specification Rev. 2.0*
 - ◆ *On-The-Go Supplement to the USB Specification Rev. 1.3*
- Small form-factor for portable applications; available in VFQFPN64 and TFBGA64
- Restriction of Hazardous Substances (RoHS) compliant, halogen-free and lead-free packages
- Low power consumption for portable applications
- Host supports data transfer at high-speed (480 Mbit/s), full-speed (12 Mbit/s), and low-speed (1.5 Mbit/s); supports disabling of high-speed mode on each port
- Peripheral supports data transfer at high-speed (480 Mbit/s) and full-speed (12 Mbit/s)
- Integrated Transaction Translator (TT) for Original USB (full-speed and low-speed) support
- Two USB ports:
 - ◆ Port 1: OTG, host, or peripheral port
 - ◆ Port 2: Host port only (supports SRP detection)
- Supports OTG HNP and SRP
- Supports 8-bit or 16-bit CPU bus interface
- Flexibility to interface with various types of processors:

- ◆ NOR Flash interface (multiplexed mode)
- ◆ NAND Flash interface (multiplexed mode)
- ◆ General multiplex interface
- ◆ SRAM interface
- Single configurable interrupt (INT) line for the host controller, peripheral controller, and OTG controller
- Integrated Phase-Locked Loop (PLL) supports external 12 MHz, 19.2 MHz, and 24 MHz crystal, and direct clock source
- Supports remote wake-up from deep sleep mode
- Supports interfacing I/O voltage of 1.8 V or 3.3 V; separate I/O voltage supply pins minimize crosstalk
- Internal voltage regulator supplies 1.2 V to the digital core
- 3.0 V to 3.6 V supply voltage input range for the internal USB transceiver
- Supports hybrid power mode; $V_{CC(3V3)}$ is not present, $V_{CC(I/O)}$ is powered
- Host controller-specific features:
 - ◆ EHCI core is adapted from *Enhanced Host Controller Interface Specification for Universal Serial Bus Rev. 1.0*
 - ◆ Integrated TT for Original USB device support on both the ports
 - ◆ Integrated 24 kB high-speed memory
 - ◆ Power switching and overcurrent reporting on per-port basis
- Peripheral controller-specific features:
 - ◆ Compliant with *Universal Serial Bus Specification Rev. 2.0*
 - ◆ Integrated 4 kB memory to support seven IN endpoints, seven OUT endpoints, and one fixed control IN/OUT endpoint
 - ◆ V_{BUS} detection in deep sleep mode
- OTG controller-specific features:
 - ◆ Supports OTG HNP and SRP using status and control registers for the software implementation in OTG dual-role devices
 - ◆ Integrated V_{BUS} voltage comparators
 - ◆ Integrated cable (ID) detector
 - ◆ Programmable timers with high resolution (0.01 ms to 80 ms)

3. Applications

The ISP1763A can be used to implement a dual-role USB device in any application, USB host or USB peripheral, depending on the cable connection. If the dual-role device is connected to a USB peripheral, it behaves like a USB host. The dual-role device can also be connected to a PC or any other USB host, and behave like a USB peripheral.

3.1 Host or peripheral roles

- TV/TV box:
 - ◆ Play, upload, or download media files from or to USB memory disk
- DVD player:
 - ◆ Play, upload, or download media files from or to USB memory disk
- Mobile phone to or from:

- ◆ Mobile phone: exchange contact information
- ◆ Digital still camera: e-mail pictures or upload pictures to the web
- ◆ MP3 player: upload or download/broadcast music
- ◆ Mass storage: upload or download files
- ◆ Scanner: scan business cards
- Printer
- Netbook
- Set-top box

4. Ordering information

Table 1. Ordering information

Commercial product code	Package description	Packing	Minimum sellable quantity
ISP1763AETTM	TFBGA64; 64 balls; body 4 × 4 × 0.8 mm	13 inch tape and reel non-dry pack	4000 pieces
ISP1763AHNUM	VFQFPN64; 64 terminals; body 9 × 9 × 1.0 mm	13 inch tape and reel dry pack	1000 pieces

5. Marking

Table 2. Marking codes

Type number	Marking code ^[1]
ISP1763AETTM	1763A
ISP1763AHNUM	1763A

[1] The package marking is the first line of text on the IC package and can be used for IC identification.

6. Block diagram

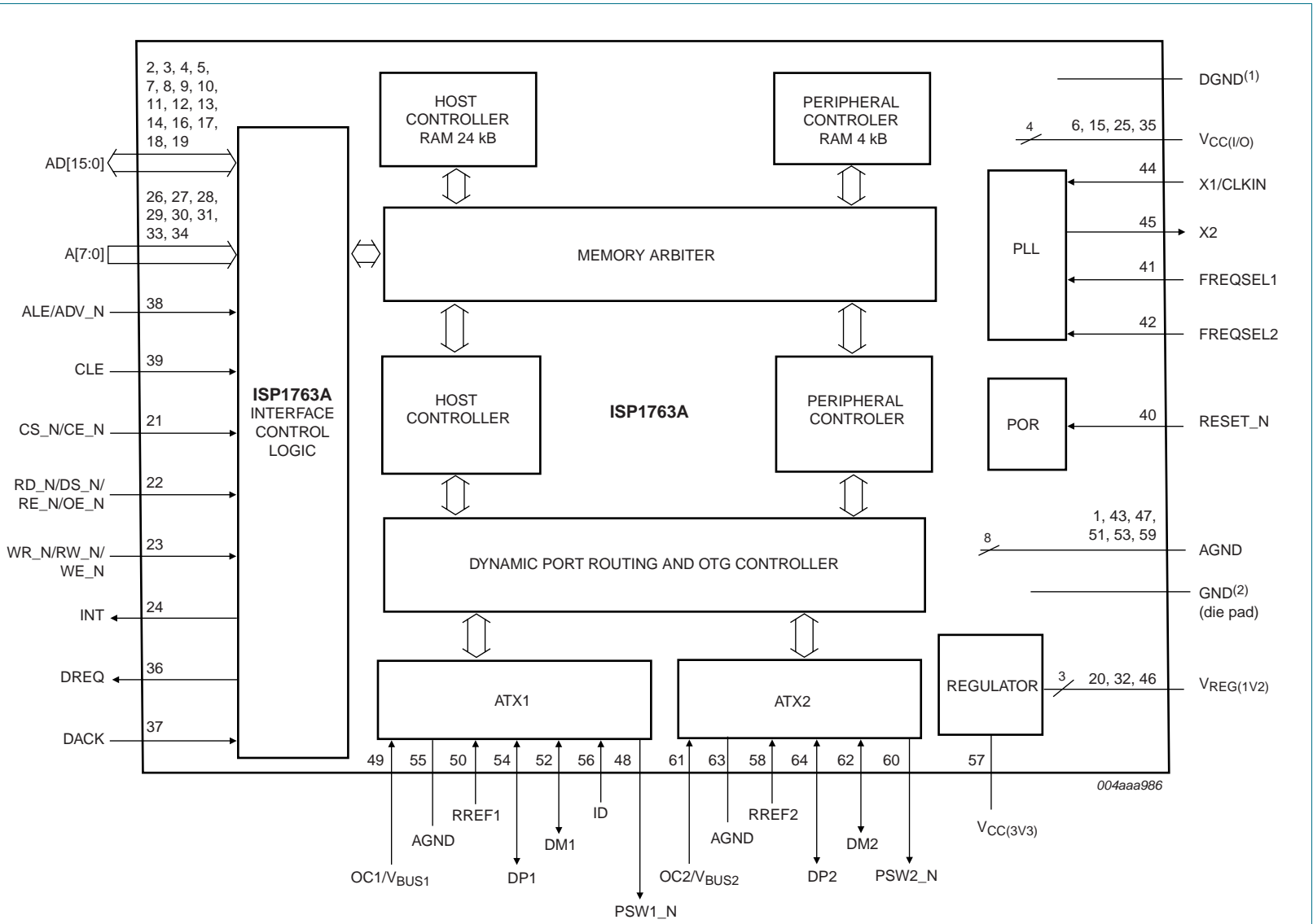

The figure shows the VFQFPN pinout. For the TFBGA ballout, see [Table 3](#).

- (1) Only applicable to the TFBGA package.
- (2) Only applicable to the VFQFPN package.

Fig 1. Block diagram

7. Pinning information

7.1 Pinning

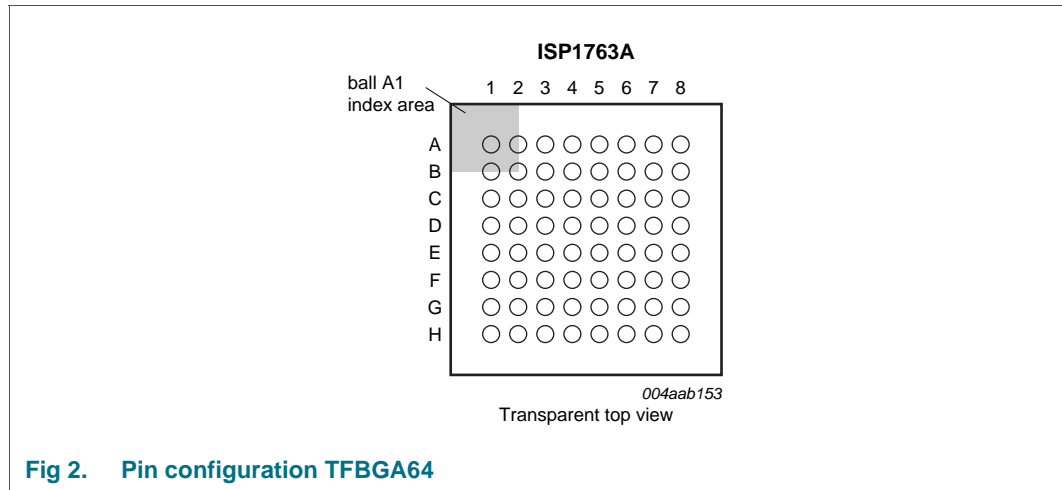

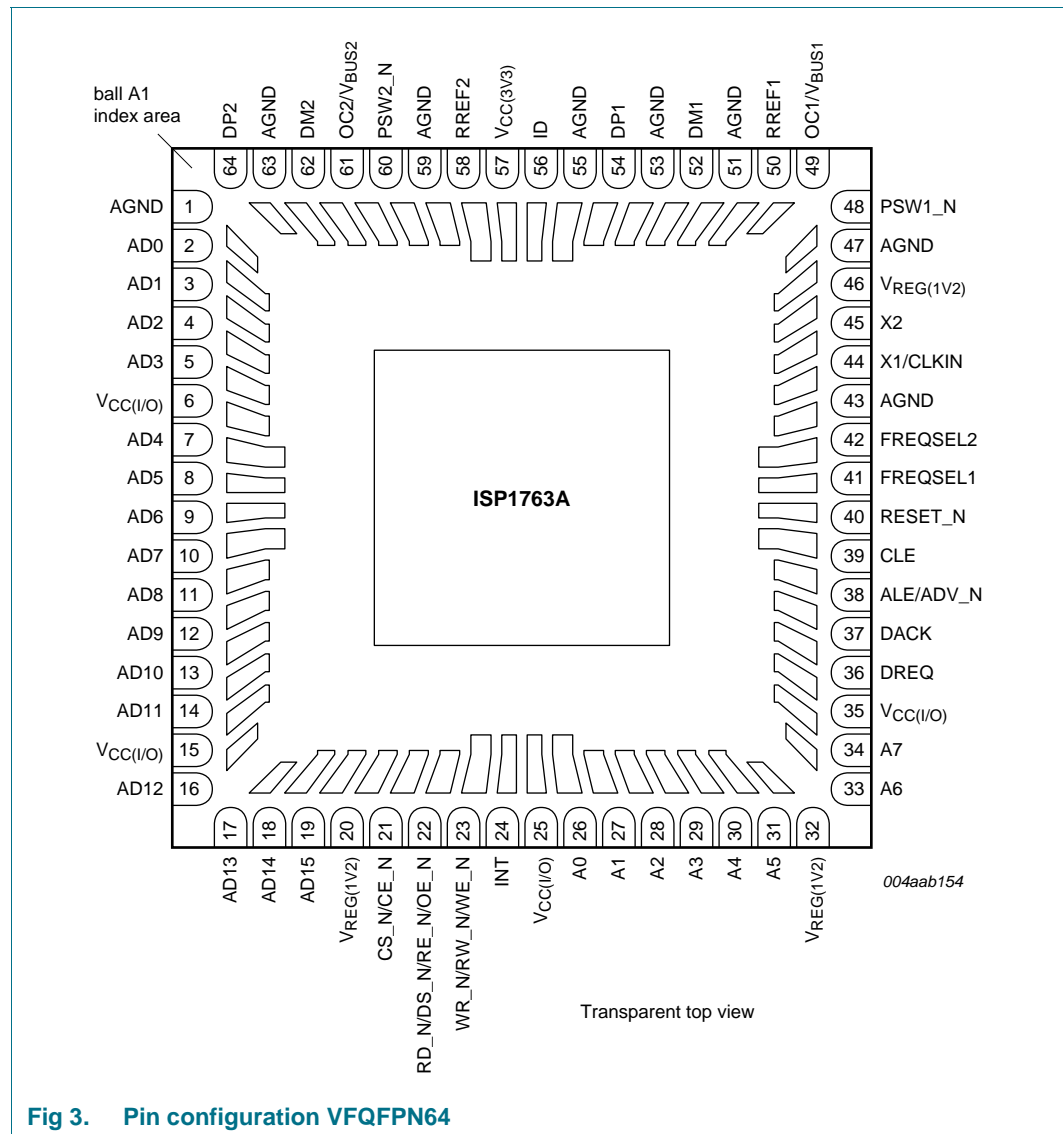

Fig 3. Pin configuration VFQFPN64

7.2 Pin description

Table 3. Pin description

Symbol ^[1]	Pin		Type ^[2]	Description
	TFBGA64	VFQFPN64		
AGND	B2	1	P	analog ground
AD0	B1	2	I/O	bit 0 of the address and data bus bidirectional pad; push-pull input; three-state output; 3.3 V tolerant
AD1	C2	3	I/O	bit 1 of the address and data bus bidirectional pad; push-pull input; three-state output; 3.3 V tolerant
AD2	C1	4	I/O	bit 2 of the address and data bus bidirectional pad; push-pull input; three-state output; 3.3 V tolerant

Table 3. Pin description ...continued

Symbol ^[1]	Pin		Type ^[2]	Description
	TFBGA64	VFQFPN64		
AD3	C3	5	I/O	bit 3 of the address and data bus bidirectional pad; push-pull input; three-state output; 3.3 V tolerant
V _{CC(I/O)}	D2	6	P	I/O supply voltage; connect a 0.1 μF decoupling capacitor
AD4	D1	7	I/O	bit 4 of the address and data bus bidirectional pad; push-pull input; three-state output; 3.3 V tolerant
AD5	C4	8	I/O	bit 5 of the address and data bus bidirectional pad; push-pull input; three-state output; 3.3 V tolerant
AD6	E1	9	I/O	bit 6 of the address and data bus bidirectional pad; push-pull input; three-state output; 3.3 V tolerant
AD7	E2	10	I/O	bit 7 of the address and data bus bidirectional pad; push-pull input; three-state output; 3.3 V tolerant
AD8	F1	11	I/O	bit 8 of the address and data bus bidirectional pad; push-pull input; three-state output; 3.3 V tolerant
AD9	D3	12	I/O	bit 9 of the address and data bus bidirectional pad; push-pull input; three-state output; 3.3 V tolerant
AD10	D4	13	I/O	bit 10 of the address and data bus bidirectional pad; push-pull input; three-state output; 3.3 V tolerant
AD11	G1	14	I/O	bit 11 of the address and data bus bidirectional pad; push-pull input; three-state output; 3.3 V tolerant
V _{CC(I/O)}	F2	15	P	I/O supply voltage; connect a 0.1 μF decoupling capacitor
AD12	E3	16	I/O	bit 12 of the address and data bus bidirectional pad; push-pull input; three-state output; 3.3 V tolerant
AD13	H1	17	I/O	bit 13 of the address and data bus bidirectional pad; push-pull input; three-state output; 3.3 V tolerant
AD14	G2	18	I/O	bit 14 of the address and data bus bidirectional pad; push-pull input; three-state output; 3.3 V tolerant
AD15	H2	19	I/O	bit 15 of the address and data bus bidirectional pad; push-pull input; three-state output; 3.3 V tolerant
V _{REG(1V2)}	H3	20	P	core power 1.2 V; connect a 4.7 μF decoupling capacitor either on this pin or on pin 46 (ball C7)

Table 3. Pin description ...continued

Symbol ^[1]	Pin		Type ^[2]	Description
	TFBGA64	VFQFPN64		
CS_N/CE_N	G3	21	I	chip select input; 3.3 V tolerant
RD_N/DS_N/ RE_N/OE_N	F3	22	I	read enable, write, or read latch; when not in use, connect to $V_{CC(I/O)}$ input; 3.3 V tolerant
WR_N/RW_N/ WE_N	H4	23	I	write enable; when not in use, connect to $V_{CC(I/O)}$ input; 3.3 V tolerant
INT	G4	24	O	interrupt output Remark: When the ISP1763A is in power-down mode, the INT pin is a high-impedance I/O. External pull-down resistors are recommended to minimize the I/O leakage. push-pull output; 3.3 V tolerant
$V_{CC(I/O)}$	F4	25	P	I/O supply voltage; connect a 0.1 μ F decoupling capacitor
A0	H5	26	I	bit 0 of the address bus; when not in use, connect to GND input; 3.3 V tolerant
A1	G5	27	I	bit 1 of the address bus; when not in use, connect to GND input; 3.3 V tolerant
A2	H6	28	I	bit 2 of the address bus; when not in use, connect to GND input; 3.3 V tolerant
A3	E4	29	I	bit 3 of the address bus; when not in use, connect to GND input; 3.3 V tolerant
A4	H7	30	I	bit 4 of the address bus; when not in use, connect to GND input; 3.3 V tolerant
A5	G6	31	I	bit 5 of the address bus; when not in use, connect to GND input; 3.3 V tolerant
$V_{REG(1V2)}$	H8	32	P	core power 1.2 V input; for normal operation, this pin must be connected to pin 20 or pin 46 for the VFQFPN64 package and ball H3 or ball C7 for the TFBGA64 package
A6	F5	33	I	bit 6 of the address bus; when not in use, connect to GND input; 3.3 V tolerant
A7	G7	34	I	bit 7 of the address bus; when not in use, connect to GND input; 3.3 V tolerant
$V_{CC(I/O)}$	F6	35	P	I/O supply voltage; connect a 0.1 μ F decoupling capacitor
DREQ	G8	36	O	DMA request; when not in use, pull-down to GND through a 10 k Ω resistor Remark: When the ISP1763A is in power-down mode, the DREQ pin is a high-impedance I/O. External pull-down resistors are recommended to minimize the I/O leakage. push-pull output; 3.3 V tolerant
DACK	F7	37	I	DMA acknowledge; when not in use, connect to GND through a 10 k Ω resistor input; 3.3 V tolerant

Table 3. Pin description ...continued

Symbol ^[1]	Pin		Type ^[2]	Description
	TFBGA64	VFQFPN64		
ALE/ADV_N	F8	38	I	address latch enable input; 3.3 V tolerant
CLE	E6	39	I	command latch enable input; 3.3 V tolerant
RESET_N	E7	40	I	internal regulator power-down control; when not in use, connect to V _{CC(I/O)} input; 3.3 V tolerant
FREQSEL1	E8	41	I	input clock frequency selection pin 1 input; 3.3 V tolerant
FREQSEL2	D8	42	I	input clock frequency selection pin 2 input; 3.3 V tolerant
AGND	D7	43	P	analog ground
X1/CLKIN	C8	44	AI	crystal oscillator or clock input; 1.2 V peak input allowed
X2	B8	45	AO	crystal oscillator output; leave open if an external clock is applied on pin X1/CLKIN
V _{REG(1V2)}	C7	46	P	core power 1.2 V; connect a 4.7 μF decoupling capacitor either on this pin or on pin 20 (ball H3)
AGND	-	47	P	analog ground
DGND	E5	-	P	digital ground
PSW1_N	D6	48	OD	port 1 power switch; when not in use, connect to V _{CC(3V3)} through a 10 kΩ resistor open-drain output; 5 V tolerant
OC1/V _{BUS1}	A8	49	AI/O	<ul style="list-style-type: none"> overcurrent input (OC1) for the host functionality; an external power switch is used V_{BUS1} for the OTG and peripheral functionality; connected to V_{BUS} detectors, and V_{BUS} SRP charge and discharge circuit. When not in use, connect to V _{CC(3V3)} through a 10 kΩ resistor. 5 V tolerant
RREF1	A7	50	AI	port 1 reference resistor connection; see Section 8.12.4
AGND	B7	51	P	analog ground
DM1	A6	52	AI/O	port 1 DM; connect to the D- pin of the USB connector
AGND	B6	53	P	analog ground
DP1	A5	54	AI/O	port 1 DP; connect to the D+ pin of the USB connector
AGND	C6	55	P	port 1 analog GND
ID	B5	56	AI	port 1 ID pin (an internal pull-up resistor is present on this pin)
V _{CC(3V3)}	A4	57	P	supply voltage
RREF2	A3	58	AI	port 2 reference resistor connection; see Section 8.12.4
AGND	C5	59	P	analog ground
PSW2_N	B4	60	OD	port 2 power switch; when not in use, connect to V _{CC(3V3)} through a 10 kΩ resistor open-drain output; 5 V tolerant

Table 3. Pin description ...continued

Symbol ^[1]	Pin		Type ^[2]	Description
	TFBGA64	VFQFPN64		
OC2/V _{BUS2}	D5	61	AI	port 2 overcurrent input or V _{BUS} detection; when not in use, connect to V _{CC(3V3)} through a 10 kΩ resistor 5 V tolerant
DM2	A2	62	AI/O	port 2 DM; connect to the D– pin of the USB connector
AGND	B3	63	P	port 2 analog ground
DP2	A1	64	AI/O	port 2 DP; connect to the D+ pin of the USB connector
GND	-	die pad	P	ground supply; down bonded to the exposed die pad (heat sink); to be connected to the PCB ground

[1] Symbol names ending with underscore N (for example, NAME_N) represent active-LOW signals.

[2] I = input only; O = output only; I/O = digital input/output; OD = open-drain output; AI = analog input; AO = analog output; AI/O = analog input/output; P = power or ground.

8. Functional description

8.1 CPU bus interface

The ISP1763A has a fast advance general-purpose interface to communicate with most types of microcontrollers and microprocessors. This microcontroller interface is configured using pins ALE/ADV_N and CLE to accommodate most types of interfaces. The bus interface supports 8-bit and 16-bit, which can be configured using bit DATA_BUS_WIDTH. Four bus interface types are selected using inputs ALE/ADV_N and CLE during power-up, the RD_N/DS_N/RE_N/OE_N and CS_N/CE_N pins, or the RESET_N pin. [Table 4](#) provides details of bus configurations for each mode.

Table 4. Bus configuration modes

Bus mode	ALE/ADV_N	CLE	DATA_BUS_WIDTH	Signal description
SRAM 8-bit	HIGH	HIGH	1	<ul style="list-style-type: none"> A[7:0]: 8-bit address bus AD[7:0]: 8-bit data bus Write (WR_N), read (RD_N), chip select (CS_N): control signals for normal SRAM mode Write (WR_N/RW_N), data strobe (DS_N), chip select (CS_N): control signals for proprietary SRAM mode (see Figure 14) DACK: DMA acknowledge input DREQ: DMA request output
SRAM 16-bit	HIGH	HIGH	0	<ul style="list-style-type: none"> A[7:0]: 8-bit address bus AD[15:0]: 16-bit data bus Write (WR_N), read (RD_N), chip select (CS_N): control signals Write (WR_N/RW_N), data strobe (DS_N), chip select (CS_N): control signals for proprietary SRAM mode (see Figure 14) DACK: DMA acknowledge input DREQ: DMA request output
NAND 8-bit	LOW	LOW	1	<ul style="list-style-type: none"> AD[7:0]: 8-bit data bus ALE, CLE, write enable, read enable (RE_N), chip enable: control signals
NAND 16-bit	LOW	LOW	0	<ul style="list-style-type: none"> AD[15:0]: 16-bit data bus ALE, CLE, write enable, read enable, chip enable: control signals
NOR 8-bit	HIGH	LOW	1	<ul style="list-style-type: none"> AD[7:0]: 8-bit data bus ADV_N, write enable, output enable, chip select: control signals

Table 4. Bus configuration modes ...continued

Bus mode	ALE/ADV_N	CLE	DATA_BUS_WIDTH	Signal description
NOR 16-bit	HIGH	LOW	0	<ul style="list-style-type: none"> AD[15:0]: 16-bit data bus ADV_N, write enable, output enable, chip select: control signals
General multiplex 8-bit	LOW	HIGH	1	<ul style="list-style-type: none"> AD[7:0]: 8-bit data bus ALE, write (WR_N), read (RD_N), chip select: control signals
General multiplex 16-bit	LOW	HIGH	0	<ul style="list-style-type: none"> AD[15:0]: 16-bit data bus ALE, write (WR_N), read (RD_N), chip select: control signals

Table 5. Pinning information of the bus interface

SRAM mode	NAND mode	NOR mode	General multiplex mode	Type	Description
AD[15:0]	AD[15:0]	AD[15:0]	AD[15:0]	I/O	data or address bus
A[7:0]	-	-	-	I	address bus
-	ALE	ADV_N	ALE	I	address or command valid
-	CLE	-	-	I	address or command valid
CS_N	CE_N	CS_N	CS_N	I	chip select
Read/data strobe	RE_N	OE_N	read/data strobe	I	read control
Write/read or write	WE_N	WE_N	write/read or write	I	write control
INT	INT	INT	INT	O	interrupt request
DREQ	-	-	DREQ	O	DMA request
DACK	-	-	DACK	I	DMA acknowledge

8.2 Interface mode lock

The bus interface can be locked in any of the modes, SRAM, NAND, NOR, or general multiplex, using bit 3 of the HW Mode Control register. To lock the interface in a particular mode:

1. Read bits 7 and 6 of the SW Reset register.
2. Set bit 3 of the HW Mode Control register to logic 1.
3. Read bits 7 and 6 of the SW Reset register to ensure that the interface is locked in the desired mode.

8.3 SRAM bus interface mode

The bus interface will be in SRAM 16-bit mode if pins ALE/ADV_N and CLE are HIGH, when:

- The CS_N/CE_N pin goes LOW, and the RD_N/DS_N/RE_N/OE_N pin goes LOW, or
- The RESET_N pin goes from LOW to HIGH.

Then, if the DATA_BUS_WIDTH bit is set, the bus interface will be in SRAM 8-bit mode.

In SRAM mode, A[7:0] is the 8-bit address bus and AD[15:0] is the separate 16-bit data bus. The ISP1763A pins RD_N/DS_N/RE_N/OE_N and WR_N/RW_N/WE_N are the read and write strobes. The SRAM bus interface supports both 8-bit and 16-bit bus width that can be configured by setting or clearing bit DATA_BUS_WIDTH. The DMA transfer is also applicable to this interface.

8.4 NAND bus interface mode

The bus interface will be in NAND 16-bit mode if pins ALE/ADV_N and CLE are LOW, when:

- The CS_N/CE_N pin goes LOW, and the RD_N/DS_N/RE_N/OE_N pin goes LOW, or
- The RESET_N pin goes from LOW to HIGH.

Then, if the DATA_BUS_WIDTH bit is set, the bus interface will be in NAND 8-bit mode.

The NAND bus interface supports most advance application processors. The command-address-data multiplexed bus is an 8-bit or 16-bit connection. The NAND Flash interface access consists of three phases: command, address, and data. The command phase is ignored. The address in the NAND Flash interface is sequentially sent in address cycles. For the ISP1763A application, an 8-bit address is sufficient to address all on-chip registers and buffers; see [Figure 4](#). The last byte address latched will be the accessed address if there are several address cycles.

The data length can vary from one byte to multiple bytes. For example, to access the data port of the peripheral controller, the maximum data length can reach 1024 bytes.

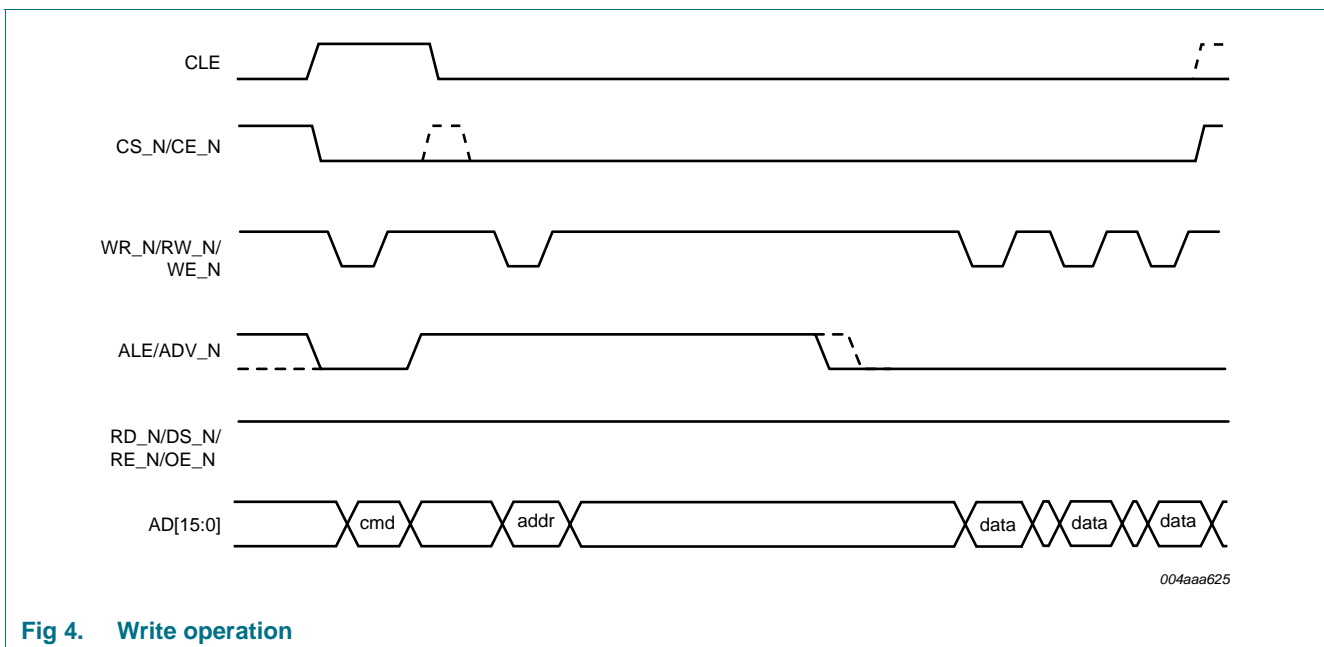

Fig 4. Write operation

8.5 NOR bus interface mode

The bus interface will be in NOR 16-bit mode, if pin ALE/ADV_N is HIGH and pin CLE is LOW, when:

- The CS_N/CE_N pin goes LOW, and the RD_N/DS_N/RE_N/OE_N pin goes LOW, or

- The RESET_N pin goes from LOW to HIGH.

Then if the DATA_BUS_WIDTH bit is set, the bus interface will be in NOR 8-bit mode.

The NOR Flash interface access consists of two phases: address and data.

The address is valid when CS_N/CE_N and ADV_N are LOW, and the address is latched at the rising edge of ADV_N. For a read operation, WE_N must be HIGH. OE_N is the data output control. When active, the addressed register or the buffer data is driven to the I/O bus. The read operation is completed when CS_N/CE_N is deasserted. For a write operation, OE_N must be HIGH. The WE_N assertion can start when ADV_N is deasserted. WE_N is the data input strobe signal. When deasserted, data will be written to the addressed register or the buffer. The write operation is completed when CS_N/CE_N is deasserted.

8.6 General multiplex bus interface mode

The bus interface will be in general multiplex 16-bit mode, if pin ALE/ADV_N is LOW and pin CLE is HIGH, when:

- The CS_N/CE_N pin goes LOW, and the RD_N/DS_N/RE_N/OE_N pin goes LOW, or
- The RESET_N pin goes from LOW to HIGH.

Then if the DATA_BUS_WIDTH bit is set, the bus interface will be in general multiplex 8-bit mode. The general multiplex bus interface supports most advance application processors. The general multiplex interface access consists of two phases: address and data.

The address is valid when ALE/ADV_N goes HIGH, and the address is latched at the falling edge of ALE/ADV_N. For a read operation, WR_N/RW_N/WE_N must be HIGH. RD_N/DS_N/RE_N/OE_N is the data output control. When active, the addressed register or the buffer data is driven to the I/O bus. The read operation is completed when CS_N/CE_N is deasserted. For a write operation, RD_N/DS_N/RE_N/OE_N must be HIGH. The WR_N/RW_N/WE_N assertion can start when ALE/ADV_N is deasserted. WR_N/RW_N/WE_N is the data input strobe signal. When deasserted, data will be written to the addressed register or the buffer. The write operation is completed when CS_N/CE_N is deasserted. The DMA transfer is also applicable to this interface.

8.7 DMA controller

The DMA controller of the ISP1763A is used to transfer data between the system memory and local buffers. It shares data bus AD[15:0] and control signals WR_N/RW_N/WE_N, RD_N/DS_N/RE_N/OE_N, and CS_N/CE_N. The logic is dependent on the bus interface mode setting.

DREQ is from the ISP1763A to indicate the start of DMA. DACK is used to differentiate if data transferred is for the DMA or PIO access. When DACK is asserted, it indicates that it is still in DMA mode. When DACK is deasserted, it indicates that PIO is to be accessed. ALE/ADV_N and CLE (address phase) are ignored in a DMA access cycle. Correct data will be captured only on the data phase (the rising edge of WR_N/RW_N/WE_N and RD_N/DS_N/RE_N/OE_N). The DMA controller of the ISP1763A has only one DMA channel. Therefore, only one DMA transfer may take place at a time.

The ISP1763A supports only counter mode. Dynamically assign the DMA transfer counter for each DMA transfer. The transfer ends once the transfer counter reaches zero. If the transfer counter is larger than the burst counter, the DREQ signal will deassert at the end of each burst transfer. DREQ will re-assert at the beginning of each burst.

For a 16-bit DMA transfer, the minimum burst length is 2 bytes. This means that the burst length is only one DMA cycle. Therefore, DREQ and DACK will assert and deassert at each DMA cycle.

In peripheral DMA, the bits in the Interrupt Reason register will be asserted to indicate that the DMA transfer has either successfully completed or terminated. Setting the control bits in the DMA Command register will start, stop, or reset the DMA transfer.

Table 6. Register address

Device register	CPU address	Host register	CPU address	OTG register	CPU address
Address	00h	USBCMD	8Ch	OTG Control (set)	E4h
Mode	0Ch	USBSTS	90h	OTG Control (clear)	E6h
Interrupt Configuration	10h	FRINDEX	98h	OTG Status (RD only)	E8h
Debug	12h	CONFIGFLAG	9Ch	OTG Interrupt Latch (set)	ECh
DcInterruptEnable	14h	PORTSC1	A0h	OTG Interrupt Latch (clear)	EEh
Endpoint Index	2Ch	ISO PTD Done Map	A4h	OTG Interrupt Enable Fall (set)	F0h
Control Function	28h	ISO PTD Skip Map	A6h	OTG Interrupt Enable Fall (clear)	F2h
Data Port	20h	ISO PTD Last PTD	A8h	OTG Interrupt Enable Rise (set)	F4h
Buffer Length	1Ch	INT PTD Done Map	AAh	OTG Interrupt Enable Rise (clear)	F6h
DcBufferStatus	1Eh	INT PTD Skip Map	ACh	OTG Timer (lower word: set)	F8h
EPMaxPacketSize	04h	INT PTD Last PTD	A Eh	OTG Timer (lower word: clear)	FAh
Endpoint Type	08h	ATL PTD Done Map	B0h	OTG Timer (higher word: set)	FCh
DMA Command	30h	ATL PTD Skip Map	B2h	OTG Timer (higher word: clear)	FEh
DMA Transfer Counter	34h	ATL PTD Last PTD	B4h		
DcDMAConfiguration	38h	HW Mode Control	B6h		
DMA Hardware	3Ch	SW Reset	B8h		
DMA Interrupt Reason	50h	HcBufferStatus	BAh		
DMA Interrupt Enable	54h	HcDMAConfiguration	BCh		
DMA Endpoint	58h	ATL Done Timeout	C0h		
DMA Burst Counter	64h	Memory	C4h		
DcInterrupt	18h	Data	C6h		
Chip ID	70h	Edge Interrupt Count	C8h		
Frame Number	74h	DMA Start Address	CCh		
Scratch	78h	DMA Data Port	60h		
Unlock Device	7Ch	Power Down Control	D0h		
Interrupt Pulse Width	80h	HcInterrupt	D4h		
Test Mode	84h	HcInterruptEnable	D6h		
		ISO IRQ MASK OR	D8h		
		INT IRQ MASK OR	DAh		
		ATL IRQ MASK OR	DCh		

Table 6. Register address ...continued

Device register	CPU address	Host register	CPU address	OTG register	CPU address
		ISO IRQ MASK AND	DEh		
		INT IRQ MASK AND	E0h		
		ATL IRQ MASK AND	E2h		

8.8 On-The-Go (OTG) controller

8.8.1 Introduction

OTG is a supplement to the Hi-Speed USB specification that augments existing USB peripherals by adding to these peripherals limited host capability to support other targeted USB peripherals. It is primarily targeted at portable devices because it addresses concerns related to such devices, such as a small connector and low power. Non-portable devices, even standard hosts, can also benefit from OTG features.

The ISP1763A OTG controller is designed to perform all the tasks specified in the OTG supplement. It supports HNP and SRP for dual-role devices. The ISP1763A uses the software implementation of HNP and SRP for maximum flexibility. A set of OTG registers provides the control and status monitoring capabilities to support software HNP or SRP.

USB transceivers, timers, and analog components required by OTG are also integrated on-chip. The analog components include:

- Voltage comparators
- Pull-up or pull-down resistors on data lines
- Charging or discharging resistors for V_{BUS}

8.8.2 Dual-role device

When port 1 of the ISP1763A is configured in OTG mode, it can be used as an OTG dual-role device. A dual-role device is a USB device that can function either as a host or as a peripheral. As a host, the ISP1763A can support all four types of transfers, control, bulk, isochronous, and interrupt, at high-speed, full-speed, or low-speed. As a peripheral, the ISP1763A can support two control endpoints, and up to seven IN endpoints and seven OUT endpoints that can be programmed to any of the four transfer types.

The default role of the ISP1763A is controlled by the ID pin, which in turn is controlled by the type of plug connected to the micro-AB receptacle. If ID = LOW (micro-A plug connected), it becomes an A-device, which is a host by default. If ID = HIGH (micro-B plug connected), it becomes a B-device, which is a peripheral by default.

Both the A-device and the B-device work on a session basis. A session is defined as the period of time during which devices exchange data. A session starts when V_{BUS} is driven and ends when V_{BUS} is turned off. Both the A-device and the B-device may start a session. During a session, the role of the host can be transferred back and forth between the A-device and the B-device any number of times by using HNP.

If the A-device wants to start a session, it turns on V_{BUS} by enabling the external charge pump. The B-device detects that V_{BUS} has risen above the B_SESS_VLD level and assumes the role of a peripheral asserting its pull-up resistor on the DP line. The A-device detects the remote pull-up resistor and assumes the role of a host. Then the A-device can

communicate with the B-device as long as it wishes. When the A-device finishes communicating with the B-device, the A-device turns off V_{BUS} and both the devices finally go into the idle state.

If the B-device wants to start a session, it must initiate SRP by data line pulsing and V_{BUS} pulsing. When the A-device detects any of these SRP events, it turns on its V_{BUS} . (Note: only the A-device is allowed to drive V_{BUS} .) The B-device assumes the role of a peripheral, and the A-device assumes the role of a host. The A-device detects that the B-device can support HNP by getting the OTG descriptor from the B-device. The A-device will then enable the HNP hand-off by using SetFeature (b_hnp_enable) and then go into the suspend state. The B-device signals it is claiming the host role by deasserting its pull-up resistor. The A-device acknowledges by going into the peripheral state. The B-device then assumes the role of a host and communicates with the A-device as long as it wishes. When the B-device finishes communicating with the A-device, both the devices finally go into the idle state.

8.8.3 Session Request Protocol (SRP)

As a dual-role device, the ISP1763A can initiate and respond to SRP. The B-device initiates SRP by data line pulsing, followed by V_{BUS} pulsing. The A-device can detect data line pulsing.

8.8.3.1 B-device initiating SRP

The ISP1763A can initiate SRP by performing the following steps:

1. Detect initial conditions (read ID_GND, B_SESS_END, and SE0_2MS of the OTG Interrupt Source register).
2. Start data line pulsing (set DP_PULLUP of the OTG Control register to logic 1).
3. Wait for 5 ms to 10 ms.
4. Stop data line pulsing (set DP_PULLUP of the OTG Control register to logic 0).
5. Start V_{BUS} pulsing (set VBUS_CHRG of the OTG Control register to logic 1).
6. Wait for 10 ms to 20 ms.
7. Stop V_{BUS} pulsing (set VBUS_CHRG of the OTG Control register to logic 0).
8. Discharge V_{BUS} for about 30 ms (by using VBUS_DISCHRG of the OTG Control register), optional.

The B-device must complete both data line pulsing and V_{BUS} pulsing within 100 ms.

8.8.3.2 A-device responding to SRP

The A-device must be able to respond to one of the two SRP events: data line pulsing or V_{BUS} pulsing.

8.8.4 Host Negotiation Protocol (HNP)

HNP is used to transfer control of the host role between the default host (A-device) and the default peripheral (B-device) during a session. When the A-device is ready to give up its role as a host, it will condition the B-device using SetFeature (b_hnp_enable) and will go into suspend. If the B-device wants to use the bus at that time, it signals a disconnect to the A-device. Then, the A-device will take the role of peripheral and the B-device will take the role of a host.

8.8.4.1 Sequence of HNP events

The sequence of events for HNP as observed on the USB bus is illustrated in [Figure 5](#).

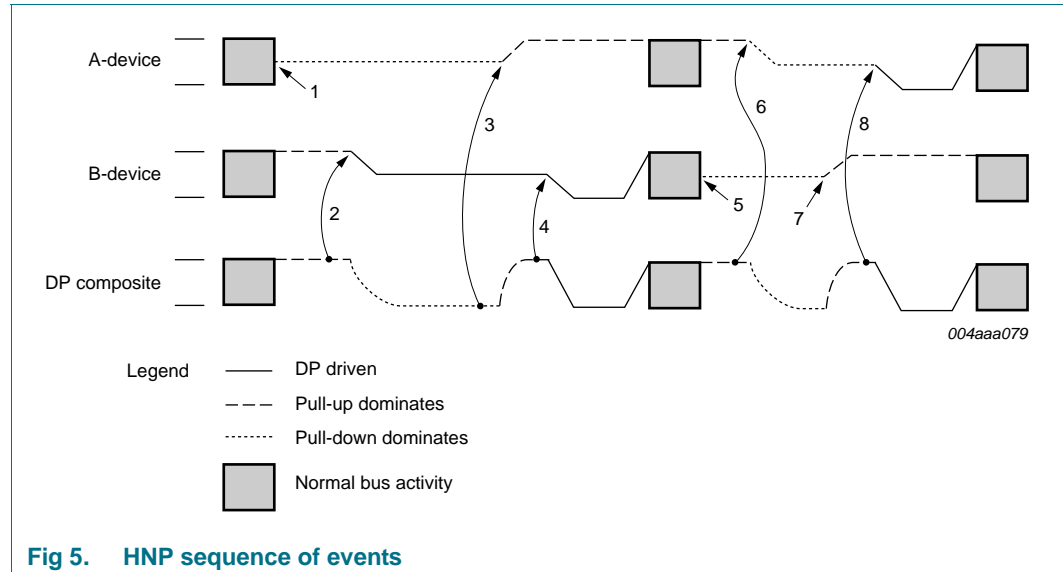

Fig 5. HNP sequence of events

As can be seen in [Figure 5](#):

1. The A-device completes using the bus and stops all bus activity (that is, suspends the bus).
2. The B-device detects that the bus is idle for more than 5 ms and begins HNP by turning off the pull-up on DP. This allows the bus to discharge to the SE0 state.
3. The A-device detects SE0 on the bus and recognizes this as a request from the B-device to become a host. The A-device responds by turning on its DP pull-up within 3 ms of first detecting SE0 on the bus.
4. After waiting for 30 μ s to ensure that the DP line is not HIGH because of the residual effect of the B-device pull-up, the B-device notices that the DP line is HIGH and the DM line is LOW, that is, J state. This indicates that the A-device has recognized the HNP request from the B-device. At this point, the B-device becomes a host and asserts bus reset to start using the bus. The B-device must assert the bus reset, that is, SE0, within 1 ms of the time that the A-device turns on its pull-up.
5. When the B-device completes using the bus, it stops all bus activities. Optionally, the B-device may turn on its DP pull-up at this time.
6. The A-device detects lack of bus activity for more than 3 ms and turns off its DP pull-up. Alternatively, if the A-device has no further need to communicate with the B-device, the A-device may turn off V_{BUS} and end the session.
7. The B-device turns on its pull-up.
8. After waiting 30 μ s to ensure that the DP line is not HIGH because of the residual effect of the A-device pull-up, the A-device notices that the DP line is HIGH (and the DM line is LOW) indicating that the B-device is signaling a connect and is ready to respond as a peripheral. At this point, the A-device becomes a host and asserts the bus reset to start using the bus.

8.8.5 Power saving in the idle state and during wake-up

The ISP1763A can be put in power saving mode if the OTG device is not in a session. This significantly reduces the power consumption. In this mode, both the peripheral controller and the host controller are suspended, the PLL and the oscillator are stopped, and the external charge pump is in the suspend state.

As an OTG device, however, the ISP1763A is required to respond to SRP events. To support this, a LazyClock is kept running when the chip is in power-saving mode. An SRP event will wake up the chip, that is, enable the PLL and the oscillator. Besides this, an ID change or B_SESS_VLD detection can also wake up the chip. These wake-up events can be enabled or disabled by programming the related bits of the OTG Interrupt Enable register before putting the chip in power saving mode. If the bit is set, then the corresponding event (status change) will wake up the ISP1763A. If the bit is cleared, then the corresponding event will not wake up the ISP1763A.

You can also wake up the ISP1763A from power-saving mode by using the software. This is accomplished by accessing any of the ISP1763A registers. Accessing a register will assert CS_N/CE_N and RD_N/DS_N/RE_N/OE_N of the ISP1763A, and therefore, set it awake.

8.9 USB host controller

8.9.1 ISP1763A USB host controller and hub internal architecture

The EHCI block and the Hi-Speed USB hub block are the main components of the advanced slave host controller.

The EHCI is the latest generation design with improved data bandwidth. The EHCI in the ISP1763A is adapted from *Enhanced Host Controller Interface Specification for Universal Serial Bus Rev. 1.0*.

The internal Hi-Speed USB hub block replaces the companion host controller block used in the original architecture of a PCI Hi-Speed USB host controller to handle full-speed and low-speed modes. The host controller of the ISP1763A architecture is a simplified hardware architecture that helps reduce cost and development time by eliminating the additional work involved in implementing the OHCI software required to support full-speed and low-speed modes.

[Figure 6](#) shows the internal architecture of the ISP1763A host controller. The ISP1763A host controller implements an EHCI that has one internal port, the root hub port 1 (not available externally), on which the internal hub is connected. The two external ports are always routed to the internal hub. The internal hub is a Hi-Speed USB, including the TT.

At power-on reset, followed by the host controller reset and initialization, the internal root hub port 1 will be polled until a new connection is detected showing the connection of the internal hub.

The internal Hi-Speed USB hub is enumerated using a sequence similar to a standard Hi-Speed USB hub enumeration sequence, and the polling on the root hub is stopped because the internal Hi-Speed USB hub will never be disconnected.

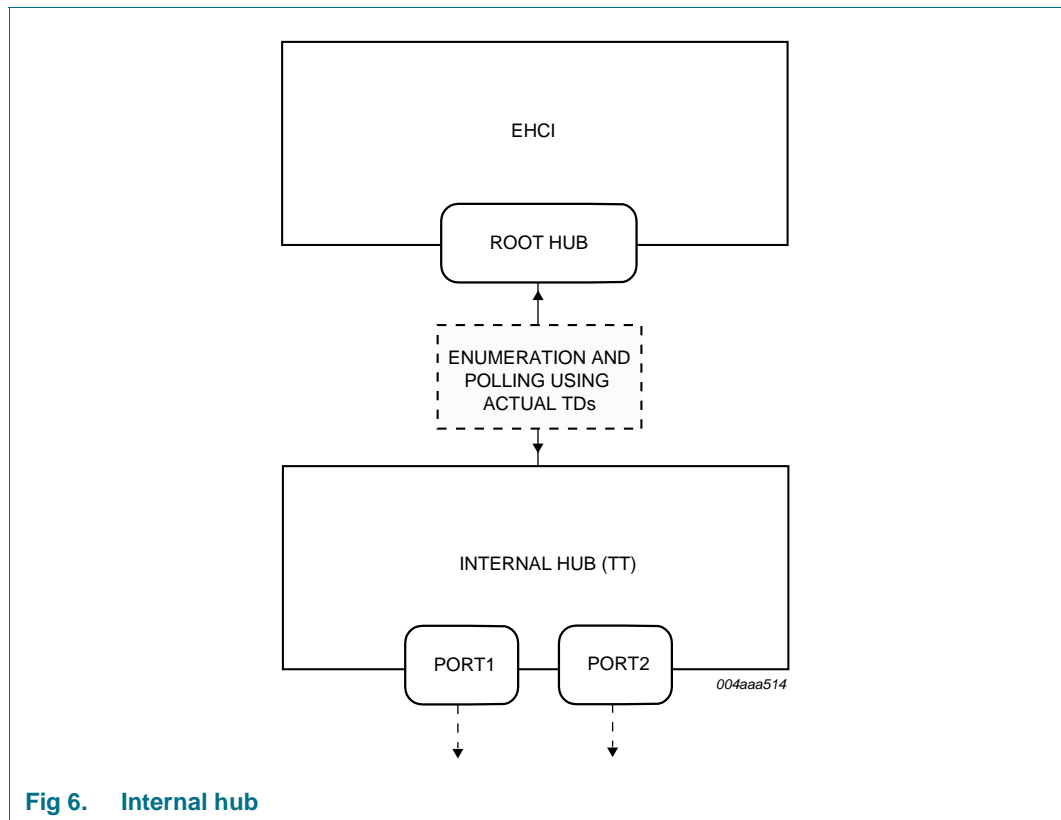

Fig 6. Internal hub

8.9.2 Host controller buffer memory block

8.9.2.1 General considerations

The internal addressable host controller buffer memory is 24 kB.

The total amount of memory allocated to the payload determines the maximum transfer size specified by a PTD, a larger internal memory size results in lesser CPU interruption for transfer programming. This means less time spent in context switching, resulting in better CPU usage.

A larger buffer also implies a larger amount of data to be transferred. This transfer, however, can be done over a longer period of time, to maintain overall system performance. Each transfer of the USB data on the USB bus can span up to a few milliseconds before requiring further CPU intervention for data movement.

The internal architecture of the ISP1763A host controller allows a flexible definition of the memory buffer for optimization of the data transfer on the CPU extension bus and the USB. It is possible to implement different data transfer schemes, depending on the number and type of USB devices present. For example, push-pull: data can be written to half of the memory while data in the other half is accessed by the host controller and sent on the USB bus. This is useful especially when a high-bandwidth continuous or periodic data flow is required.

8.9.2.2 Structure of the host controller memory

The internal memory is 24 kB: 4 kB PTD area and 20 kB payload area.

Both the PTD and payload memory zones are divided into three dedicated areas for each main type of USB transfer: Isochronous (ISO), Interrupt (INT), and Asynchronous Transfer List (ATL). As shown in [Table 7](#), the PTD areas for ISO, INT, and ATL are grouped at the beginning of the memory, occupying address range 0400h to 0FFFh, following the registers address space. The payload or data area occupies the next memory address range 1000h to 5FFFh, meaning that 20 kB of memory is allocated for the payload data.

A maximum of 16 PTD areas and their allocated payload areas can be defined for each type of transfer. The structure of a PTD is similar for every transfer type and consists of eight Double Words (DWs) that must be correctly programmed for correct USB data transfer. The reserved bits of a PTD must be set to logic 0. A detailed description of the PTD structure can be found in [Section 10.4](#).

The transfer size specified by the PTD determines the contiguous USB data transfer that can be performed without any CPU intervention. The respective payload memory area must be equal to the transfer size defined. The maximum transfer size is flexible and can be optimized, depending on the number and nature of USB devices or PTDs defined and their respective MaxPacketSize.

The RAM is structured in blocks of PTDs and payloads so that while the USB is executing on an active transfer-based PTD, the processor can simultaneously fill up another block area in the RAM. A PTD and its payload can then be updated on-the-fly without stopping or delaying any other USB transaction or corrupting the RAM data.

Some of the design features are:

- The internal memory contains isochronous, interrupt, and asynchronous PTDs, and defined payloads.
- Internal memory address range calculation:

Memory address = (CPU address – 0400h) (shift right >> 3). The base address is 0400h.

Table 7. Memory address

Memory map	CPU address	Memory address	Memory accessing
ISO PTD	0400h to 05FFh	0000h to 007Fh	<ul style="list-style-type: none"> • Configure the Memory register <ul style="list-style-type: none"> – Bits 14 to 0: start address 1000h to 5FFFh – Bit 15: reserved
INT PTD	0800h to 09FFh	0080h to 00FFh	
ATL PTD	0C00h to 0DFFh	0100h to 017Fh	
Payload	1000h to 5FFFh	0180h to 0B7Fh	<ul style="list-style-type: none"> • Read/write data from or to the Data register (address C6h of the ISP1763A). • The memory burst read and write is ended by any register access (other than C6h).

Both the CPU interface logic and the USB host controller require access to the internal ISP1763A RAM at the same time. The internal arbiter controls these accesses to the internal memory, organized internally on a 64-bit data bus width, allowing a maximum bandwidth of 240 MB/s. This bandwidth avoids any bottleneck on accesses both from the CPU interface and the internal USB host controller.

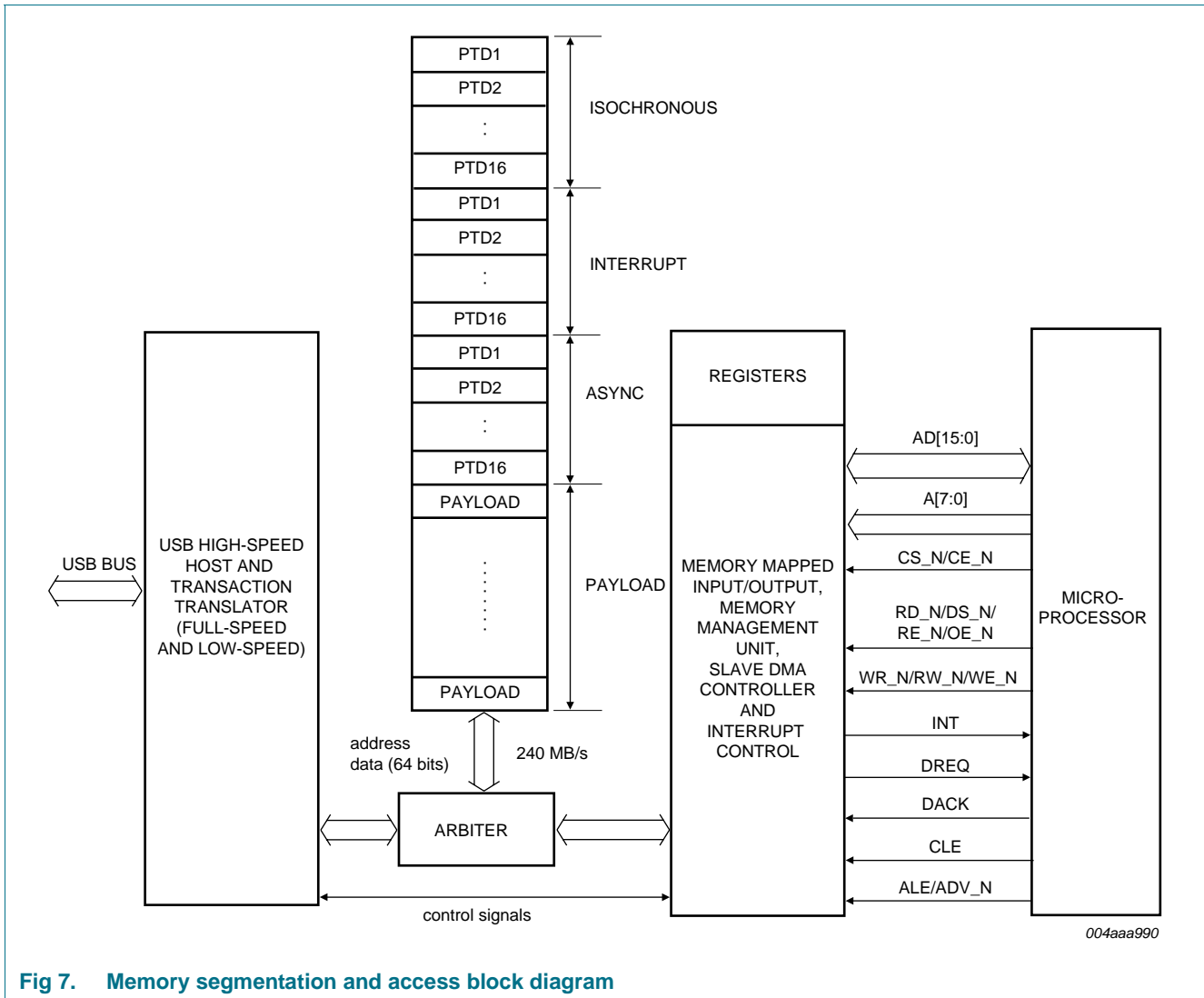

Fig 7. Memory segmentation and access block diagram

8.9.3 Interrupts

The ISP1763A will generate an INT according to the source or event in the HcInterrupt register. The main steps to enable the INT assertion are:

1. Set GLOBAL_INTR_EN (bit 0) in the HW Mode Control register.
2. Define the INT active as level or edge in INTR_LEVEL (bit 1) of the HW Mode Control register.
3. Define the INT polarity as active LOW or HIGH in INTR_POL (bit 2) of the HW Mode Control register. These settings must match the INT settings of the host processor. By default, interrupt is level-triggered and active LOW.
4. Program the individual interrupt enable bits in the HcInterruptEnable register. The software will need to clear the interrupt status bits in the HcInterrupt register before enabling individual interrupt enable bits.

Additional INT characteristics can be adjusted in the Edge Interrupt Count register, as necessary, applicable only when INT is set to be edge-active; a pulse of a defined width is generated every time INT is active.

Bits 15 to 0 of the Edge Interrupt Count register will define the INT pulse width. The maximum pulse width that can be programmed is FFFFh, corresponding to a 1 ms pulse width. This setting is necessary for certain processors that may require a different minimum INT pulse width than the default value. The default INT width set at power-on is about 500 ns.

Bits 31 to 24 of the Edge Interrupt Count register define the minimum interval between two interrupts to avoid frequent INT received by the CPU. The default value of 00h attributed to these bits determines the normal INT generation, without any delay. When a delay is programmed and the INT becomes active after that delay, several INT events may already have occurred.

All the interrupt events are represented by the respective bits allocated in the HclInterrupt register. There is no mechanism to show the order or the moment occurrence of an interrupt.

The asserted bits in the HclInterrupt register can be cleared by writing back the same value to the HclInterrupt register. This means that writing logic 1 to each of the set bits will reset those bits to the initial inactive state.

The INT generation rules that apply according to the preceding settings are:

- If an interrupt event occurs but the corresponding bit in the HclInterruptEnable register is not set, then the corresponding HclInterrupt register bit is set but the interrupt signal is not asserted.
An interrupt will be generated when interrupt is enabled and the source is set.
- For a level-trigger, an interrupt signal remains asserted until the processor clears the HclInterrupt register by writing logic 1 to clear the HclInterrupt register bits that are set.
- If an interrupt is made edge-sensitive and is asserted, writing to clear the HclInterrupt register will not have any effect because the interrupt will be asserted for a prescribed number of clock cycles.
- The clock stopping mechanism does not affect the generation of an interrupt. This is useful during the suspend and resume cycles, when an interrupt is generated to signal a wake-up event.

The INT generation can also be conditioned by programming the IRQ MASK OR and IRQ MASK AND registers.

With the help of the IRQ MASK AND and IRQ MASK OR registers for each type of transfer, the software can determine which PTDs get priority and an interrupt will be generated when the AND or OR conditions are met. The PTDs that are set will wait until the respective bits of the remaining PTDs are set and then all PTDs generate an interrupt request to the CPU together.

The registers definition shows that the AND or OR conditions are applicable to the same category of PTDs: ISO, INT, and ATL.

When an INT is generated, the PTD Done Map registers and the respective V bits will show which PTDs were completed.

The rules that apply to IRQ MASK AND or IRQ MASK OR settings are:

- The OR mask has a higher priority over the AND mask. An INT is generated if bit n of the done map is set and the corresponding bit n of the OR MASK register is set.
- If the OR mask for any done bit is not set, then the AND mask comes into picture. An INT is generated if all the corresponding done bits of the AND MASK register are set. For example: If bits 2, 4, and 10 are set in the AND MASK register, an INT is generated only if bits 2, 4, and 10 of done map are set.
- If using the INT interval setting for the bulk PTD, an interrupt will only occur at the regular time interval as programmed in the ATL Done Timeout register.
Even if an interrupt occurs before the time-out of the register, no INT will be generated until the time is up.

Example: Using IRQ MASK AND or IRQ MASK OR, without ATL Timeout register.

The AND function: activate the INT only if PTDs 1, 2, and 4 are done.

The OR function: if any of the PTDs 7, 8, or 9 are done, an INT for each of the PTDs will be raised.

Table 8. Using the IRQ MASK AND or IRQ MASK OR registers

PTD	AND register	OR register	Time	PTD done	INT
1	1	0	1 ms	1	-
2	1	0	-	1	-
3	0	0	-	-	-
4	1	0	3 ms	1	active because of AND
5	0	0	-	-	-
6	0	0	-	-	-
7	0	1	5 ms	1	active because of OR
8	0	1	6 ms	1	active because of OR
9	0	1	7 ms	1	active because of OR

8.10 USB peripheral controller

8.10.1 Introduction

The design of the peripheral controller in the ISP1763A is compatible with the *ISP1582 Hi-Speed Universal Serial Bus peripheral controller* IC. The functionality of the peripheral controller in the ISP1763A is similar to the ISP1582. In addition, the register sets are similar, with only a few variations.

The USB Chapter 9 protocol handling and data transfer operation of the peripheral controller are executed using an external firmware. The external microcontroller or microprocessor can access the peripheral controller-specific registers through the local bus interface. The transfer of data between a microprocessor and the peripheral controller can be done in PIO mode.

8.10.2 Peripheral controller data transfer operation

The following sections explain how the peripheral controller in the ISP1763A handles an IN data transfer and an OUT data transfer. An IN data transfer means transfer from the ISP1763A to an external USB host, through the upstream port. An OUT transfer means transfer from an external USB host to the ISP1763A. In peripheral mode, the ISP1763A acts as a USB peripheral.

8.10.2.1 IN data transfer

- The arrival of the IN token is detected by the Serial Interface Engine (SIE) by decoding the Packet Identifier (PID).
- The SIE also checks the device number and the endpoint number to verify whether they are okay.
- If the endpoint is enabled, the SIE checks the endpoint status. If the endpoint is full and data in the buffer is validated, the contents of the buffer memory are sent during the data phase; else a NAK handshake is sent.
- After the data phase, the SIE expects a handshake (ACK) from the host, except for ISO endpoints.
- On receiving the handshake (ACK), the SIE updates the contents of the endpoint status and interrupt registers, which in turn generates an interrupt to the microprocessor. For ISO endpoints, the DcInterrupt register is updated as soon as data is sent because there is no handshake phase.
- On receiving an interrupt, the microprocessor reads the DcInterrupt register. It knows which endpoint has generated the interrupt. If the buffer is empty, it fills up the buffer so that data can be sent by the SIE at the next IN token phase.

8.10.2.2 OUT data transfer

- The arrival of the OUT token is detected by the SIE by decoding the PID.
- The SIE checks the device and endpoint numbers to verify whether they are okay.
- If the endpoint is enabled, the SIE checks the status of the endpoint. If the endpoint is empty, data from the USB host is stored in the buffer memory during the data phase, else a NAK handshake is sent.
- After the data phase, the SIE sends a handshake (ACK) to the host, except for ISO endpoints.
- The SIE updates the endpoint status and interrupt registers, which in turn generates an interrupt to the microprocessor. For ISO endpoints, the DcInterrupt register is updated as soon as data is received because there is no handshake phase.
- On receiving an interrupt, the microprocessor reads the DcInterrupt register. It knows which endpoint has generated the interrupt. If the buffer is full, it empties the buffer so that data can be received by the SIE at the next OUT token phase.

8.10.3 Endpoint description

Each USB peripheral is logically composed of several independent endpoints. An endpoint acts as a terminus of a communication flow between the USB host and the USB device. At design time, each endpoint is assigned a unique endpoint identifier, see [Table 9](#). The combination of the peripheral address (given by the host during enumeration), the endpoint number, and the transfer direction allows each endpoint to be

uniquely referenced.

The peripheral controller has 4 kB of internal FIFO memory, which is shared among the enabled USB endpoints. The two control endpoints are fixed 64 bytes long. Any of the seven IN and seven OUT endpoints can separately be enabled or disabled. The endpoint type (interrupt, isochronous, or bulk) and packet size of these endpoints can individually be configured, depending on the requirements of the application. Optional double buffering increases the data throughput of these data endpoints.

Table 9. Endpoint access and programmability

Endpoint identifier	Maximum packet size	Double buffering	Endpoint type	Direction
EP0RX	64 bytes (fixed)	no	control OUT	OUT
EP0TX	64 bytes (fixed)	no	control IN	IN
EP1RX	programmable	yes	programmable	OUT
EP1TX	programmable	yes	programmable	IN
EP2RX	programmable	yes	programmable	OUT
EP2TX	programmable	yes	programmable	IN
EP3RX	programmable	yes	programmable	OUT
EP3TX	programmable	yes	programmable	IN
EP4RX	programmable	yes	programmable	OUT
EP4TX	programmable	yes	programmable	IN
EP5RX	programmable	yes	programmable	OUT
EP5TX	programmable	yes	programmable	IN
EP6RX	programmable	yes	programmable	OUT
EP6TX	programmable	yes	programmable	IN
EP7RX	programmable	yes	programmable	OUT
EP7TX	programmable	yes	programmable	IN

8.10.4 Peripheral controller suspend

The peripheral controller in the ISP1763A detects a USB suspend when constant idle state is present on the USB bus for 3 ms.

The steps leading the peripheral controller to the suspend state are as follows:

1. If there is no SOF for 3 ms, the peripheral controller in the ISP1763A sets bit SUSP of the DcInterrupt register. This will generate an interrupt if bit IESUSP of the DcInterruptEnable register is set.
2. When the firmware detects a suspend condition through bit IESUSP, it must prepare all system components for the suspend state.
3. In the interrupt service routine, the firmware must check the current status of the USB bus. When bit VBUSSTAT of the Mode register is logic 0, the USB bus has left suspend mode and the process must be aborted. Otherwise, the next step can be executed.
4. To meet the suspend current requirements for a bus-powered device, internal clocks must be switched off by clearing bit CLKAON of the Mode register.

5. When the firmware has set and cleared the GOSUSP bit of the Mode register, the peripheral controller in the ISP1763A enters the suspend state. A flag must be set by the firmware to indicate that the peripheral controller is in the suspend state.

The peripheral controller in the ISP1763A will remain in the suspend state for at least 5 ms, before responding to wake-up events, such as global resume or chip select active.

8.10.5 Peripheral controller resume

Wake-up from the suspend state is initiated either by the USB host or by the application:

- USB host: drives a K-state on the USB bus (global resume).
- Application: remote wake-up using a LOW pulse on pins CS_N/CE_N and RD_N/DS_N/RE_N/OE_N, if enabled using bit WKUPCS of the Mode register.

The steps of a wake-up sequence are as follows:

1. The internal oscillator and the PLL multiplier are re-enabled. When stabilized, clock signals are routed to all internal circuits of the peripheral controller in the ISP1763A.
2. The RESUME bit of the DcInterrupt register is set. This will generate an interrupt if bit IERESM of the DcInterruptEnable register is set.
3. The peripheral controller in the ISP1763A resumes its normal functionality 5 ms after starting the wake-up sequence. The firmware can clear its suspend state flag at this point.
4. After resume, the internal registers of the peripheral controller in the ISP1763A are write-protected to prevent corruption by inadvertent writing during power-up of external components. The firmware must send an Unlock Device command to the peripheral controller in the ISP1763A to restore its full functionality.

8.10.6 Remote wake-up

In a remote wake-up to the host, the firmware must set and clear the SNDRSU bit of the Mode register. The peripheral controller in the ISP1763A will drive a resume signal (a K-state) on the USB bus for 10 ms after a 5 ms delay.

8.11 Phase-Locked Loop (PLL) clock multiplier

The internal PLL supports 12 MHz, 19.2 MHz, or 24 MHz input, which can be a crystal or a clock already existing in the system. The frequency selection can be done using the FREQSEL1 and FREQSEL2 pins.

No external components are required for the PLL operation.

8.12 Power management

The ISP1763A is mainly designed for mobile applications that require more precision power saving control to achieve extremely low power consumption. It implements a flexible power management scheme that allows various stages of power saving.

8.12.1 Power supply

Power supplies are defined in [Table 10](#).

Table 10. Power supply

Symbol	Voltage range	Description
$V_{CC(I/O)}$	1.65 V to 1.95 V or 3.0 V to 3.6 V	supply for the I/O pad
$V_{CC(3V3)}$	3.0 V to 3.6 V	supply for USB transceivers, cores, and analog modules

8.12.2 Power modes

8.12.2.1 Operation mode

All power supplies are present. Consists of host mode, peripheral mode, and idle mode.

8.12.2.2 Suspend mode

All power supplies are present. Possible defined states are host-only suspend, peripheral-only suspend, or both.

For the peripheral suspend procedure, see [Section 8.10.4](#).

The steps for the host suspend are as follows:

1. Clear the RS bit of the USBCMD register to stop the host controller from executing schedule.
2. Set the SUSP bit and clear the FPR bit of the PORTSC1 register to force the host controller to go into suspend.

8.12.2.3 Deep sleep mode

All power supplies are present. Regulator is in suspend mode. The clocks of the host controller and the peripheral controller are turned off.

The steps to enter deep sleep mode are:

1. The peripheral must be in suspend state or disabled. See [Section 8.10.4](#).
2. Clear the RS bit of the USBCMD register to stop the host controller from executing schedule.
3. Clear the CLKAON bit in the Mode register to save power.
4. Set the REG_PWR and REG_SUSP_PWR bits of the Power Down Control register to logic 1 to force the regulator to go into suspend mode.

8.12.2.4 Power-down mode

The regulator is powered down. The ISP1763A has no functionality. The ISP1763A can be woken up by a dummy read signal, that is, both RD_N/DS_N/RE_N/OE_N and CS_N/CE_N are active LOW.

The ISP1763A enters power-down mode when any of the following conditions is met:

- Bit REG_PWR of the Power Down Control register is set to logic 0.
- RESET_N is asserted.

8.12.2.5 ISP1763A wake up

The regulator will be in normal operating mode and the clock will be enabled when either of these conditions are triggered:

- Application: Dummy read access with a LOW pulse on pins CS_N/CE_N and RD_N/DS_N/RE_N/OE_N.
- Host: Remote wake up from the external USB device.
- Host: V_{BUS} overcurrent condition triggered on the system.
- Peripheral: Resume signaling received from the external USB host.

8.12.2.6 Isolation mode

All power supplies are not present. Although V_{BUS} may be present, it will not activate the chip or damage it.

8.12.3 Power-up and reset sequence

When $V_{CC(I/O)}$ and $V_{CC(3V3)}$ are on, it is recommended that the system generates a RESET_N pulse to ensure that the ISP1763A regulator is in the power-down state. The regulator will be powered on when the system generates a dummy read (ignore return value) access to the ISP1763A. An internal POR pulse will be generated during the regulator powers on, so that internal circuits are in reset state after the regulator power is stable.

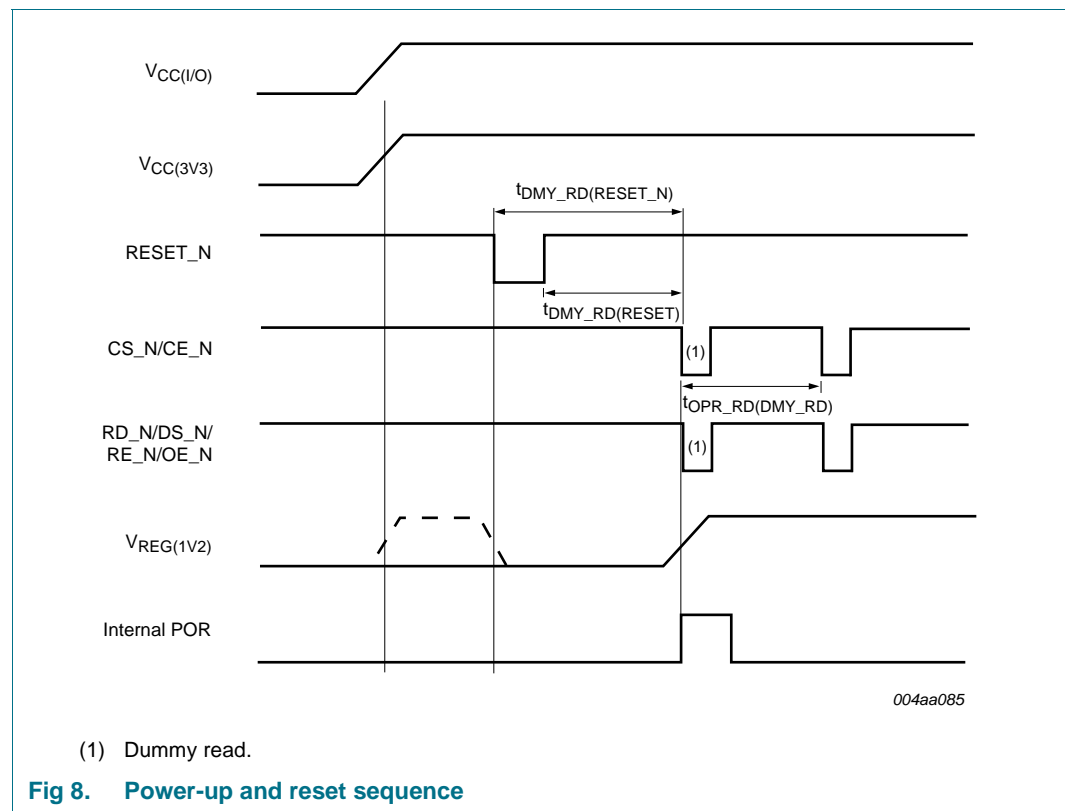

8.12.4 ATX reference voltage

The ATX circuit provides a stable internal voltage reference to bias the analog circuitry. This circuit requires an accurate external reference resistor. Connect $12\text{ k}\Omega \pm 1\%$ resistor between pins RREF1, RREF2, and GND.

9. OTG controller-specific registers

Table 11. Overview of OTG controller-specific registers

Address	Register	Reset value	Access ^[1]	Reference
OTG control register				
Set — E4h Clear — E6h	OTG Control	8086h	R/S/C	Section 9.1.1 on page 30
OTG interrupt registers				
E8h	OTG Interrupt Source	1188h	R	Section 9.2.1 on page 31
Set — ECh Clear — EEh	OTG Interrupt Latch	0000h	R/S/C	Section 9.2.2 on page 32
Set — F0h Clear — F2h	OTG Interrupt Enable Fall	0000h	R/S/C	Section 9.2.3 on page 33
Set — F4h Clear — F6h	OTG Interrupt Enable Rise	0000h	R/S/C	Section 9.2.4 on page 34
OTG timer register				
Timer_Low_Word_Set — F8h Timer_Low_Word_Clear — FAh Timer_High_Word_Set — FCh Timer_High_Word_Clear — FEh	OTG Timer	0000h	R/S/C	Section 9.3.1 on page 35

[1] The R/S/C access type represents a field that can be read, set, or cleared (set to 0). A set register is used to configure the function that is defined in the bit field of the register. The clear register is used to clear the configuration setting. Logic 1 in a bit field clears the function that is defined by the bit in the set register.

9.1 OTG control register

9.1.1 OTG Control register

[Table 12](#) shows the bit allocation of the register.

Table 12. OTG_CTRL - OTG Control register (address set: E4h, clear: E6h) bit allocation

Bit	15	14	13	12	11	10	9	8
Symbol	HC_2_DIS	reserved	TMR_SEL	reserved		OTG_DISABLE	OTG_SE0_EN	BDIS_ACON_EN
Reset	1	0	0	0	0	0	0	0
Access	R/S/C	R/S/C	R/S/C	R/S/C	R/S/C	R/S/C	R/S/C	R/S/C
Bit	7	6	5	4	3	2	1	0
Symbol	SW_SEL_HC_DC	VBUS_CHRG	VBUS_DISCHRG	VBUS_DRV	reserved	DM_PULL_DOWN	DP_PULL_DOWN	DP_PULL_UP
Reset	1	0	0	0	0	1	1	0
Access	R/S/C	R/S/C	R/S/C	R/S/C	R/S/C	R/S/C	R/S/C	R/S/C

Table 13. OTG_CTRL - OTG Control register (address set: E4h, clear: E6h) bit description

Bit	Symbol	Description
15	HC_2_DIS	0 — Port 2 is enabled as host. 1 — Port 2 is disabled.
14	-	reserved
13	TMR_SEL	Port 1 peripheral suspend timer select 0 — 3.1 ms 1 — 3.0 ms
12 to 11	-	reserved
10	OTG_DISABLE	0 — OTG functionality is enabled. 1 — OTG disabled; pure host or peripheral.
9	OTG_SE0_EN	This bit is used by the host controller to send SE0 on remote connect. 0 — No SE0 sent on remote connect detection. 1 — SE0 (bus reset) sent on remote connect detection. Remark: This bit is normally set when the B-device goes into the B_WAIT_ACON state (recommended sequence: LOC_CONN = 0 → DELAY → 0 ms → OTG_SE0_EN = 1 → SEL_HC_DC = 0) and is cleared when it comes out of the B_WAIT_ACON state.
8	BDIS_ACON_EN	Enables the A-device to connect if the B-device disconnect is detected.
7	SW_SEL_HC_DC	In software HNP mode, this bit selects between the host controller and the peripheral controller. 0 — Host controller is connected to ATX. 1 — Peripheral controller is connected to ATX. This bit is set to logic 1 by the hardware when there is an event corresponding to the BDIS_ACON interrupt. BDIS_ACON_EN is set and there is an automatic pull-up connection on remote disconnect.
6	VBUS_CHRG	Connect V_{BUS} to $V_{CC(3V3)}$ through a resistor.
5	VBUS_DISCHRG	Discharge V_{BUS} to ground through a resistor.
4	VBUS_DRV	In OTG mode, setting this bit will turn on port 1 power. In non-OTG mode, setting this bit does not have any effect and V_{BUS} is controlled using the hub command.
3	-	reserved
2	DM_PULLDOWN	0 — Disable DM pull-down 1 — Enable DM pull-down
1	DP_PULLDOWN	0 — Disable DP pull-down 1 — Enable DP pull-down
0	DP_PULLUP	0 — The pull-up resistor is disconnected from the DP line. 1 — An internal 1.5 k Ω pull-up resistor is present on the DP line.

9.2 OTG interrupt registers

9.2.1 OTG Interrupt Source register

This register indicates the current state of the signals that can generate an interrupt. The bit allocation of the register is given in [Table 14](#).

Table 14. OTG_INTR_SRC - OTG Interrupt Source register (address E8h) bit allocation

Bit	15	14	13	12	11	10	9	8
Symbol	reserved				DP2_SRP	P2_A_SESS_VLD	OTG_TMR_TIMEOUT	B_SE0_SRP
Reset	0	0	0	1	0	0	0	1
Access	R	R	R	R	R	R	R	R
Bit	7	6	5	4	3	2	1	0
Symbol	B_SESS_END	reserved		RMT_CONN	ID	DP_SRP	A_B_SESS_VLD	VBUS_VLD
Reset	1	0	0	0	1	0	0	0
Access	R	R	R	R	R	R	R	R

Table 15. OTG_INTR_SRC - OTG Interrupt Source register (address E8h) bit description

Bit	Symbol	Description
15 to 12	-	reserved
11	DP2_SRP	Detects the DP2 pin status.
10	P2_A_SESS_VLD	Reflects the voltage on pin OC2/V _{BUS2} is above the A-device session valid threshold.
9	OTG_TMR_TIMEOUT	Reflects the OTG timer timeout.
8	B_SE0_SRP	Detects 2 ms of SE0 in the B-device idle state.
7	B_SESS_END	Reflects the voltage on pin OC1/V _{BUS1} is below the B-device session end threshold.
6 to 5	-	reserved
4	RMT_CONN	Reflects remote connection is detected.
3	ID	Reflects the ID pin status.
2	DP_SRP	Detects the DP1 pin status.
1	A_B_SESS_VLD	Reflects the voltage on pin OC1/V _{BUS1} is above the A-device session valid threshold for the A-device. Reflects the voltage on pin OC1/V _{BUS1} is above the B-device session valid threshold for the B-device.
0	VBUS_VLD	Reflects the voltage on pin OC1/V _{BUS1} is above the A-device V _{BUS} valid threshold.

9.2.2 OTG Interrupt Latch register

The OTG Interrupt Latch register indicates the source that generated the interrupt. The status of this register bits depends on the settings of the Interrupt Enable Fall and Interrupt Enable Rise registers, and the occurrence of the respective events. The bit allocation of the register is given in [Table 16](#).

Table 16. OTG_INTR_L - OTG Interrupt Latch register (address set: ECh, clear: EEh) bit allocation

Bit	15	14	13	12	11	10	9	8
Symbol	reserved				DP2_SRP_L	P2_A_SESS_VLD_L	OTG_TMR_TIMEOUT_L	B_SE0_SRP_L
Reset	0	0	0	0	0	0	0	0
Access	R/S/C	R/S/C	R/S/C	R/S/C	R/S/C	R/S/C	R/S/C	R/S/C
Bit	7	6	5	4	3	2	1	0
Symbol	B_SESS_END_L	BDIS_ACON_L	reserved	RMT_CONN_L	ID_L	DP_SRP_L	A_B_SESS_VLD_L	VBUS_VLD_L
Reset	0	0	0	0	0	0	0	0
Access	R/S/C	R/S/C	R/S/C	R/S/C	R/S/C	R/S/C	R/S/C	R/S/C

Table 17. OTG_INTR_L - OTG Interrupt Latch register (address set: ECh, clear: EEh) bit description

Bit	Symbol	Description
15 to 12	-	reserved
11	DP2_SRP_L	Set when an unmasked event occurs on DP2_SRP.
10	P2_A_SESS_VLD_L	Set when an unmasked event occurs on P2_A_SESS_VLD.
9	OTG_TMR_TIMEOUT_L	Set when an unmasked event occurs on OTG_TMR_TIMEOUT.
8	B_SE0_SRP_L	Set when an unmasked event occurs on B_SE0_SRP.
7	B_SESS_END_L	Set when an unmasked event occurs on B_SESS_END.
6	BDIS_ACON_L	Set when an unmasked event occurs on BDIS_ACON.
5	-	reserved
4	RMT_CONN_L	Set when an unmasked event occurs on RMT_CONN.
3	ID_L	Set when an unmasked event occurs on ID.
2	DP_SRP_L	Set when an unmasked event occurs on DP_SRP.
1	A_B_SESS_VLD_L	Set when an unmasked event occurs on A_B_SESS_VLD.
0	VBUS_VLD_L	Set when an unmasked event occurs on VBUS_VLD.

9.2.3 OTG Interrupt Enable Fall register

[Table 18](#) shows the bit allocation of this register that enables interrupts on transition from logic 1 to logic 0.

Table 18. OTG_INTR_EN_F - OTG Interrupt Enable Fall register (address set: F0h, clear: F2h) bit allocation

Bit	15	14	13	12	11	10	9	8
Symbol	reserved				DP2_SRP_EN_F	P2_A_SESS_VLD_EN_F	OTG_TMR_TIMEOUT_EN_F	B_SE0_SRP_EN_F
Reset	0	0	0	0	0	0	0	0
Access	R/S/C	R/S/C	R/S/C	R/S/C	R/S/C	R/S/C	R/S/C	R/S/C
Bit	7	6	5	4	3	2	1	0
Symbol	B_SESS_END_EN_F	BDIS_ACON_EN_F	reserved	RMT_CONN_EN_F	ID_EN_F	DP_SRP_EN_F	A_B_SESS_VLD_EN_F	VBUS_VLD_EN_F
Reset	0	0	0	0	0	0	0	0
Access	R/S/C	R/S/C	R/S/C	R/S/C	R/S/C	R/S/C	R/S/C	R/S/C

Table 19. OTG_INTR_EN_F - OTG Interrupt Enable Fall register (address set: F0h, clear: F2h) bit description

Bit	Symbol	Description
15 to 12	-	reserved
11	DP2_SRP_EN_F	Enable interrupt when port 2 DP transitions from logic 1 to logic 0.
10	P2_A_SESS_VLD_EN_F	Enable interrupt when port 2 A_SESS_VLD transitions from logic 1 to logic 0 for the A-device.
9	OTG_TMR_TIMEOUT_EN_F	Enable interrupt on OTG timer time-out transition from logic 1 to logic 0.
8	B_SE0_SRP_EN_F	Enable interrupt when B_SE0_SRP transitions from logic 1 to logic 0.
7	B_SESS_END_EN_F	Enable interrupt when V _{BUS} session end transitions from logic 1 to logic 0.
6	BDIS_ACON_EN_F	Enable interrupt when BDIS_ACON transitions from logic 1 to logic 0.
5	-	reserved

Table 19. OTG_INTR_EN_F - OTG Interrupt Enable Fall register (address set: F0h, clear: F2h) bit description

Bit	Symbol	Description
4	RMT_CONN_EN_F	Enable interrupt when RMT_CONN transitions from logic 1 to logic 0.
3	ID_EN_F	Enable interrupt when ID transitions from logic 1 to logic 0.
2	DP_SRP_EN_F	Enable interrupt when port 1 DP transitions from logic 1 to logic 0.
1	A_B_SESS_VLD_EN_F	Enable interrupt when AB-session valid transitions from logic 1 to logic 0.
0	VBUS_VLD_EN_F	Enable interrupt when VBUS_VLD transitions from logic 1 to logic 0.

9.2.4 OTG Interrupt Enable Rise register

This register (see [Table 20](#) for bit allocation) enables interrupts on transition from logic 0 to logic 1.

Table 20. OTG_INTR_EN_R - OTG Interrupt Enable Rise register (address set: F4h, clear: F6h) bit allocation

Bit	15	14	13	12	11	10	9	8
Symbol	reserved				DP2_SRP_EN_R	P2_A_SESS_VLD_EN_R	OTG_TMR_TIMEOUT_EN_R	B_SE0_SRP_EN_R
Reset	0	0	0	0	0	0	0	0
Access	R/S/C	R/S/C	R/S/C	R/S/C	R/S/C	R/S/C	R/S/C	R/S/C
Bit	7	6	5	4	3	2	1	0
Symbol	B_SESS_END_EN_R	BDIS_ACON_EN_R	reserved	RMT_CONN_EN_R	ID_EN_R	DP_SRP_EN_R	A_B_SESS_VLD_EN_R	VBUS_VLD_EN_R
Reset	0	0	0	0	0	0	0	0
Access	R/S/C	R/S/C	R/S/C	R/S/C	R/S/C	R/S/C	R/S/C	R/S/C

Table 21. OTG_INTR_EN_R - OTG Interrupt Enable Rise register (address set: F4h, clear: F6h) bit description

Bit	Symbol	Description
15 to 12	-	reserved
11	DP2_SRP_EN_R	Enable interrupt when port 2 DP transitions from logic 0 to logic 1.
10	P2_A_SESS_VLD_EN_R	Enable interrupt when port 2 A_SESS_VLD transitions from logic 0 to logic 1 for the A-device.
9	OTG_TMR_TIMEOUT_EN_R	Enable interrupt on OTG timer time-out transition from logic 0 to logic 1.
8	B_SE0_SRP_EN_R	Enable interrupt when B_SE0_SRP transitions from logic 0 to logic 1.
7	B_SESS_END_EN_R	Enable interrupt when V _{BUS} session end transitions from logic 0 to logic 1.
6	BDIS_ACON_EN_R	Enable interrupt when BDIS_ACON transitions from logic 0 to logic 1.
5	-	reserved
4	RMT_CONN_EN_R	Enable interrupt when RMT_CONN transitions from logic 0 to logic 1.
3	ID_EN_R	Enable interrupt when ID transitions from logic 0 to logic 1.
2	DP_SRP_EN_R	Enable interrupt when port 1 DP transitions from logic 0 to logic 1.
1	A_B_SESS_VLD_EN_R	Enable interrupt when AB-session valid transitions from logic 0 to logic 1.
0	VBUS_VLD_EN_R	Enable interrupt when VBUS_VLD transitions from logic 0 to logic 1.

9.3 OTG Timer register

9.3.1 OTG Timer register

This is a 32-bit register organized as two 16-bit fields. These two fields have separate set and clear addresses. [Table 22](#) shows the bit allocation of the register.

Table 22. OTG_TMR - OTG Timer register (address low word set: F8h, low word clear: FAh; high word set: FCh, high word clear: FEh) bit allocation

Bit	31	30	29	28	27	26	25	24
Symbol	START_TMR	reserved						
Reset	0	0	0	0	0	0	0	0
Access	R/S/C	R/S/C	R/S/C	R/S/C	R/S/C	R/S/C	R/S/C	R/S/C
Bit	23	22	21	20	19	18	17	16
Symbol	TIMER_INIT_VALUE[23:16]							
Reset	0	0	0	0	0	0	0	0
Access	R/S/C	R/S/C	R/S/C	R/S/C	R/S/C	R/S/C	R/S/C	R/S/C
Bit	15	14	13	12	11	10	9	8
Symbol	TIMER_INIT_VALUE[15:8]							
Reset	0	0	0	0	0	0	0	0
Access	R/S/C	R/S/C	R/S/C	R/S/C	R/S/C	R/S/C	R/S/C	R/S/C
Bit	7	6	5	4	3	2	1	0
Symbol	TIMER_INIT_VALUE[7:0]							
Reset	0	0	0	0	0	0	0	0
Access	R/S/C	R/S/C	R/S/C	R/S/C	R/S/C	R/S/C	R/S/C	R/S/C

Table 23. OTG_TMR - OTG Timer register (address low word set: F8h, low word clear: FAh; high word set: FCh, high word clear: FEh) bit description

Bit	Symbol	Description
31	START_TMR	This is the start/stop bit of the OTG timer. Writing logic 1 will cause the OTG timer to load TMR_INIT_VALUE into the counter and start to count. Writing logic 0 will stop the timer. This bit is automatically cleared when the OTG timer is timed out. 0 — Stop the timer. 1 — Start the timer.
30 to 24	-	reserved
23 to 0	TIMER_INIT_VALUE[23:0]	These bits define the initial value used by the OTG timer. The timer interval is 0.01 ms. Maximum time allowed is 167.772 s.

10. Host controller-specific registers

[Table 24](#) shows the bit description of the host controller-specific registers.

Table 24. Overview of host controller-specific registers

Address	Register	Reset value	References
EHCI operational registers			
8Ch	USBCMD	0000 0000h	Section 10.1.1 on page 37
90h	USBSTS	0000 0000h	Section 10.1.2 on page 37
94h	USBINTR	0000 0000h	Section 10.1.3 on page 38
98h	FRINDEX	0000 0000h	Section 10.1.4 on page 39
9Ch	CONFIGFLAG	0000 0000h	Section 10.1.5 on page 40
A0h	PORTSC1	0000 2000h	Section 10.1.6 on page 41
A4h	ISO PTD Done Map	0000h	Section 10.1.7 on page 42
A6h	ISO PTD Skip Map	FFFFh	Section 10.1.8 on page 42
A8h	ISO PTD Last PTD	0000h	Section 10.1.9 on page 43
AAh	INT PTD Done Map	0000h	Section 10.1.10 on page 43
ACh	INT PTD Skip Map	FFFFh	Section 10.1.11 on page 43
A Eh	INT PTD Last PTD	0000h	Section 10.1.12 on page 43
B0h	ATL PTD Done Map	0000h	Section 10.1.13 on page 44
B2h	ATL PTD Skip Map	FFFFh	Section 10.1.14 on page 44
B4h	ATL PTD Last PTD	0000h	Section 10.1.15 on page 44
Configuration registers			
B6h	HW Mode Control	0000h	Section 10.2.1 on page 45
B8h	SW Reset	0000h	Section 10.2.2 on page 46
BAh	HcBufferStatus	0000h	Section 10.2.3 on page 47
BCh	HcDMAConfiguration	0000h	Section 10.2.4 on page 48
C0h	ATL Done Timeout	0000 0000h	Section 10.2.5 on page 49
C4h	Memory	0000h	Section 10.2.6 on page 49
C6h	Data Port	0000h	Section 10.2.7 on page 50
C8h	Edge Interrupt Count	0000 000Fh	Section 10.2.8 on page 50
60h	DMA Data Port	-	Section 10.2.9 on page 51
CCh	DMA Start Address	0000h	Section 10.2.10 on page 51
D0h	Power Down Control	03E8 1BA0h	Section 10.2.11 on page 51
Interrupt registers			
D4h	HcInterrupt	0040h	Section 10.3.1 on page 53
D6h	HcInterruptEnable	0000h	Section 10.3.2 on page 55
D8h	ISO IRQ MASK OR	0000h	Section 10.3.3 on page 57
DAh	INT IRQ MASK OR	0000h	Section 10.3.4 on page 57
DCh	ATL IRQ MASK OR	0000h	Section 10.3.5 on page 57
DEh	ISO IRQ MASK AND	0000h	Section 10.3.6 on page 57
E0h	INT IRQ MASK AND	0000h	Section 10.3.7 on page 58
E2h	ATL IRQ MASK AND	0000h	Section 10.3.8 on page 58

10.1 EHCI operational registers

10.1.1 USBCMD register

The USB Command (USBCMD) register indicates the command to be executed by the serial host controller. Writing to this register causes a command to be executed.

[Table 25](#) shows the USBCMD register bit allocation.

Table 25. USBCMD - USB Command register (address 8Ch) bit allocation

Bit	31	30	29	28	27	26	25	24
Symbol	reserved ^[1]							
Reset	0	0	0	0	0	0	0	0
Access	R/W	R/W	R/W	R/W	R/W	R/W	R/W	R/W
Bit	23	22	21	20	19	18	17	16
Symbol	reserved ^[1]							
Reset	0	0	0	0	0	0	0	0
Access	R/W	R/W	R/W	R/W	R/W	R/W	R/W	R/W
Bit	15	14	13	12	11	10	9	8
Symbol	reserved ^[1]							
Reset	0	0	0	0	0	0	0	0
Access	R/W	R/W	R/W	R/W	R/W	R/W	R/W	R/W
Bit	7	6	5	4	3	2	1	0
Symbol	LHCR	reserved ^[1]			FLS[1:0]		HCRESET	RS
Reset	0	0	0	0	0	0	0	0
Access	R/W	R/W	R/W	R/W	R/W	R/W	R/W	R/W

[1] The reserved bits should always be written with the reset value.

Table 26. USBCMD - USB Command register (address 8Ch) bit description

Bit	Symbol	Description ^[1]
31 to 8	-	reserved
7	LHCR	Light host controller reset: It allows the driver software to reset the EHCI controller without affecting the state of the ports or the relationship to the companion host controllers. To reset, write a one followed by a zero.
6 to 4	-	reserved
3 to 2	FLS[1:0]	Frame list size: Default 00b. This field specifies the size of the frame list.
1	HCRESET	Host controller reset: This control bit is used by the software to reset the host controller. The software writes one to this bit to reset. This bit is set to zero by the host controller when the reset process is complete.
0	RS	Run/stop: 1 = Run, 0 = Stop. When set, the host controller executes the schedule.

[1] For details on register bit description, refer to *Enhanced Host Controller Interface Specification for Universal Serial Bus Rev. 1.0*.

10.1.2 USBSTS register

The USB Status (USBSTS) register indicates pending interrupts and various states of the host controller. The status resulting from a transaction on the serial bus is not indicated in this register. The software clears register bits by writing ones to them. The bit allocation is given in [Table 27](#).

Table 27. USBSTS - USB Status register (address 90h) bit allocation

Bit	31	30	29	28	27	26	25	24
Symbol	reserved ^[1]							
Reset	0	0	0	0	0	0	0	0
Access	R/W	R/W	R/W	R/W	R/W	R/W	R/W	R/W
Bit	23	22	21	20	19	18	17	16
Symbol	reserved ^[1]							
Reset	0	0	0	0	0	0	0	0
Access	R/W	R/W	R/W	R/W	R/W	R/W	R/W	R/W
Bit	15	14	13	12	11	10	9	8
Symbol	reserved ^[1]							
Reset	0	0	0	0	0	0	0	0
Access	R/W	R/W	R/W	R/W	R/W	R/W	R/W	R/W
Bit	7	6	5	4	3	2	1	0
Symbol	reserved ^[1]				FLR	PCD	reserved ^[1]	
Reset	0	0	0	0	0	0	0	0
Access	R/W	R/W	R/W	R/W	R/W	R/W	R/W	R/W

[1] The reserved bits should always be written with the reset value.

Table 28. USBSTS - USB Status register (address 90h) bit description

Bit	Symbol	Description ^[1]
31 to 4	-	reserved
3	FLR	Frame list rollover: The host controller sets this bit to logic 1 when the frame list index rolls over from its maximum value to logic 0. The exact value at which the rollover occurs depends on the FLS bits.
2	PCD	Port change detect: The host controller sets this bit to logic 1 when any port, where the PO bit is set to zero, has a bit transition from zero to one or the FPR bit transitions from zero to one as a result of a J-K transition detected on a suspended port.
1 to 0	-	reserved

[1] For details on register bit description, refer to *Enhanced Host Controller Interface Specification for Universal Serial Bus Rev. 1.0*.

10.1.3 USBINTR register

The USB Interrupt (USBINTR) bit allocation is given in [Table 29](#).

Table 29. USBINTR - USB Interrupt register (address 94h) bit allocation

Bit	31	30	29	28	27	26	25	24
Symbol	reserved ^[1]							
Reset	0	0	0	0	0	0	0	0
Access	R/W	R/W	R/W	R/W	R/W	R/W	R/W	R/W
Bit	23	22	21	20	19	18	17	16
Symbol	reserved ^[1]							
Reset	0	0	0	0	0	0	0	0
Access	R/W	R/W	R/W	R/W	R/W	R/W	R/W	R/W

Bit	15	14	13	12	11	10	9	8
Symbol	reserved ^[1]							
Reset	0	0	0	0	0	0	0	0
Access	R/W	R/W	R/W	R/W	R/W	R/W	R/W	R/W
Bit	7	6	5	4	3	2	1	0
Symbol	reserved ^[1]				FLR_IE	PCD_IE	reserved ^[1]	
Reset	0	0	0	0	0	0	0	0
Access	R/W	R/W	R/W	R/W	R/W	R/W	R/W	R/W

[1] The reserved bits should always be written with the reset value.

Table 30. USBINTR - USB Interrupt register (address 94h) bit description

Bit	Symbol	Description ^[1]
31 to 4	-	reserved
3	FLR_IE	Frame list rollover interrupt enable: When this bit is logic 1, and the Frame List Rollover bit in the USBSTS register is logic 1, the host controller will issue an interrupt. The interrupt is acknowledged by the software clearing the Frame List Rollover bit.
2	PCD_IE	Port change detect interrupt enable: When this bit is logic 1, and the Port Change Detect bit in the USBSTS register is logic 1, the host controller will issue an interrupt. The interrupt is acknowledged by the software clearing the Port Change Detect bit.
1 to 0	-	reserved

[1] For details on register bit description, refer to *Enhanced Host Controller Interface Specification for Universal Serial Bus Rev. 1.0*.

10.1.4 FRINDEX register

The Frame Index (FRINDEX) register is used by the host controller to index into the periodic frame list. The register updates every 125 μ s (once each microframe). Bits n to 3 are used to select a particular entry in the periodic frame list during periodic schedule execution. This register must be written as a double word. A byte or word write produces undefined results. This register must be written as a double word. A write to this register while the RS (Run/Stop) bit is set produces undefined results. Writes to this register also affect the SOF value.

The bit allocation is given in [Table 31](#).

Table 31. FRINDEX - Frame Index register (address: 98h) bit allocation

Bit	31	30	29	28	27	26	25	24
Symbol	reserved ^[1]							
Reset	0	0	0	0	0	0	0	0
Access	R/W	R/W	R/W	R/W	R/W	R/W	R/W	R/W
Bit	23	22	21	20	19	18	17	16
Symbol	reserved ^[1]							
Reset	0	0	0	0	0	0	0	0
Access	R/W	R/W	R/W	R/W	R/W	R/W	R/W	R/W

Bit	15	14	13	12	11	10	9	8
Symbol	reserved ^[1]		FRINDEX[13:8]					
Reset	0	0	0	0	0	0	0	0
Access	R/W	R/W	R/W	R/W	R/W	R/W	R/W	R/W
Bit	7	6	5	4	3	2	1	0
Symbol	FRINDEX[7:0]							
Reset	0	0	0	0	0	0	0	0
Access	R/W	R/W	R/W	R/W	R/W	R/W	R/W	R/W

[1] The reserved bits should always be written with the reset value.

Table 32. FRINDEX - Frame Index register (address: 98h) bit description

Bit	Symbol	Description ^[1]
31 to 14	-	reserved
13 to 0	FRINDEX[13:0]	Frame index: Bits in this register are used for the frame number in the SOF packet and as the index into the frame list. The value in this register increments at the end of each time frame.

[1] For details on register bit description, refer to *Enhanced Host Controller Interface Specification for Universal Serial Bus Rev. 1.0*.

10.1.5 CONFIGFLAG register

The bit allocation of the Configure Flag (CONFIGFLAG) register is given in [Table 33](#).

Table 33. CONFIGFLAG - Configure Flag register (address 9Ch) bit allocation

Bit	31	30	29	28	27	26	25	24
Symbol	reserved ^[1]							
Reset	0	0	0	0	0	0	0	0
Access	R/W	R/W	R/W	R/W	R/W	R/W	R/W	R/W
Bit	23	22	21	20	19	18	17	16
Symbol	reserved ^[1]							
Reset	0	0	0	0	0	0	0	0
Access	R/W	R/W	R/W	R/W	R/W	R/W	R/W	R/W
Bit	15	14	13	12	11	10	9	8
Symbol	reserved ^[1]							
Reset	0	0	0	0	0	0	0	0
Access	R/W	R/W	R/W	R/W	R/W	R/W	R/W	R/W
Bit	7	6	5	4	3	2	1	0
Symbol	reserved ^[1]							CF
Reset	0	0	0	0	0	0	0	0
Access	R/W	R/W	R/W	R/W	R/W	R/W	R/W	R/W

[1] The reserved bits should always be written with the reset value.

Table 34. CONFIGFLAG - Configure Flag register (address 9Ch) bit description

Bit	Symbol	Description ^[1]
31 to 1	-	reserved
0	CF	Configure flag: The host software sets this bit as the last action when it is configuring the host controller. This bit controls the default port-routing control logic.

[1] For details on register bit description, refer to *Enhanced Host Controller Interface Specification for Universal Serial Bus Rev. 1.0*.

10.1.6 PORTSC1 register

The Port Status and Control (PORTSC) register (bit allocation: [Table 35](#)) is in the power well. It is reset by the hardware only when the auxiliary power is initially applied or in response to a host controller reset. The initial conditions of a port are:

- No peripheral connected
- Port disabled

If the port has power control, the software cannot change the state of the port until it sets port power bits. The software must not attempt to change the state of the port until the power is stable on the port (maximum delay is 20 ms from the transition).

Table 35. PORTSC1 - Port Status and Control 1 register (address A0h) bit allocation

Bit	31	30	29	28	27	26	25	24
Symbol	reserved ^[1]							
Reset	0	0	0	0	0	0	0	0
Access	R/W	R/W	R/W	R/W	R/W	R/W	R/W	R/W
Bit	23	22	21	20	19	18	17	16
Symbol	reserved ^[1]				PTC[3:0]			
Reset	0	0	0	0	0	0	0	0
Access	R/W	R/W	R/W	R/W	R/W	R/W	R/W	R/W
Bit	15	14	13	12	11	10	9	8
Symbol	reserved ^[1]		PO	PP	LS[1:0]		reserved ^[1]	PR
Reset	0	0	1	0	0	0	0	0
Access	R/W	R/W	R/W	R/W	R/W	R/W	R/W	R/W
Bit	7	6	5	4	3	2	1	0
Symbol	SUSP	FPR	reserved ^[1]			PED	ECSC	ECCS
Reset	0	0	0	0	0	0	0	0
Access	R/W	R/W	R/W	R/W	R/W	R/W	R/W	R/W

[1] The reserved bits should always be written with the reset value.

Table 36. PORTSC1 - Port Status and Control 1 register (address A0h) bit description

Bit	Symbol	Description ^[1]
31 to 20	-	reserved
19 to 16	PTC[3:0]	Port test control: When this field is zero, the port is not operating in test mode. A non-zero value indicates that it is operating in test mode indicated by the value.
15 to 14	-	reserved

Table 36. PORTSC1 - Port Status and Control 1 register (address A0h) bit description ...continued

Bit	Symbol	Description ^[1]
13	PO	Port owner: This bit unconditionally goes to logic 0 when the configured bit in the CONFIGFLAG register makes a logic 0 to logic 1 transition. This bit unconditionally goes to logic 1 whenever the configured bit is logic 0.
12	PP	Port power: This bit will enable the root hub for the upstream port.
11 to 10	LS[1:0]	Line status: This field reflects current logical levels of the DP (bit 11) and DM (bit 10) signal lines.
9	-	reserved
8	PR	Port reset: Write logic 1 to this bit to reset the bus. Write logic 0 to this bit to terminate the bus reset sequence. ^[2]
7	SUSP	Suspend: Logic 1 means the port is in the suspend state. Logic 0 means the port is not suspended. ^[2]
6	FPR	Force port resume: Logic 1 means resume detected or driven on the port. Logic 0 means no resume (K-state) detected or driven on the port. ^[2]
5 to 3	-	reserved
2	PED	Port enabled/disabled: Logic 1 means enable. Logic 0 means disable. ^[2]
1	ECSC	Connect status change: Logic 1 means change in ECCS. Logic 0 means no change. ^[2]
0	ECCS	Current connect status: Logic 1 indicates a peripheral is present on the port. Logic 0 indicates no device is present. ^[2]

[1] For details on register bit description, refer to *Enhanced Host Controller Interface Specification for Universal Serial Bus Rev. 1.0*.

[2] These fields read logic 0, if the PP (Port Power) bit in register PORTSC1 is logic 0.

10.1.7 ISO PTD Done Map register

The bit description of the register is given in [Table 37](#).

Table 37. ISO PTD Done Map register (address A4h) bit description

Legend: * reset value

Bit	Symbol	Access	Value	Description
15 to 0	ISO_PTD_DONE_MAP[15:0]	R	0000h*	ISO PTD done map: Done map for each of the 16 PTDs for the ISO transfer.

This register represents a direct map of the done status of 16 PTDs. The bit corresponding to a particular PTD will be set to logic 1 as soon as that PTD execution is completed. Reading the done map register will clear all the bits that are set to logic 1, and the next reading will reflect the updated status of the new executed PTDs.

10.1.8 ISO PTD Skip Map register

[Table 38](#) shows the bit description of the register.

Table 38. ISO PTD Skip Map register (address A6h) bit description

Legend: * reset value

Bit	Symbol	Access	Value	Description
15 to 0	ISO_PTD_SKIP_MAP[15:0]	R/W	FFFFh*	ISO PTD skip map: Skip map for each of the 16 PTDs for the ISO transfer.

When a bit in the PTD skip map is set to logic 1, that PTD will be skipped although its V bit may be set. The information in that PTD is not processed. When the PTD is in process, the software must not set this bit. After writing to this register, add 100 ns delay before reading it.

10.1.9 ISO PTD Last PTD register

[Table 39](#) shows the bit description of the ISO PTD Last PTD register.

Table 39. ISO PTD Last PTD register (address A8h) bit description

Legend: * reset value

Bit	Symbol	Access	Value	Description
15 to 0	ISO_PTD_LAST_PTD[15:0]	R/W	0000h*	ISO PTD last PTD: Last PTD of the 16 PTDs. 1h — One PTD in ISO. 2h — Two PTDs in ISO. 4h — Three PTDs in ISO.

Once the LastPTD bit corresponding to a PTD is set, this will be the last PTD processed (checking V = 1) in that PTD category. Subsequently, processing will restart with the first PTD of that group. This is useful to reduce the time in which all the PTDs, the respective memory space, would be checked, especially if only a few PTDs are defined.

10.1.10 INT PTD Done Map register

The bit description of the register is given in [Table 40](#).

Table 40. INT PTD Done Map register (address AAh) bit description

Legend: * reset value

Bit	Symbol	Access	Value	Description
15 to 0	INT_PTD_DONE_MAP[15:0]	R	0000h*	INT PTD done map: Done map for each of the 16 PTDs for the INT transfer.

This register represents a direct map of the done status of 16 PTDs. The bit corresponding to a particular PTD will be set to logic 1 as soon as that PTD execution is completed. Reading the done map register will clear all the bits that are set to logic 1, and the next reading will reflect the updated status of the new executed PTDs.

10.1.11 INT PTD Skip Map register

[Table 41](#) shows the bit description of the INT PTD Skip Map register.

Table 41. INT PTD Skip Map register (address ACh) bit description

Legend: * reset value

Bit	Symbol	Access	Value	Description
15 to 0	INT_PTD_SKIP_MAP[15:0]	R/W	FFFFh*	INT PTD skip map: Skip map for each of the 16 PTDs for the INT transfer.

When a bit in the PTD skip map is set to logic 1, that PTD will be skipped although its V bit may be set. The information in that PTD is not processed. When the PTD is in process, the software must not set this bit. After writing to this register, add 100 ns delay before reading it.

10.1.12 INT PTD Last PTD register

The bit description of the register is given in [Table 42](#).

Table 42. INT PTD Last PTD register (address AEh) bit description

Legend: * reset value

Bit	Symbol	Access	Value	Description
15 to 0	INT_PTD_LAST_PTD[15:0]	R/W	0000h*	INT PTD last PTD: Last PTD of the 16 PTDs. 1h — One PTD in INT. 2h — Two PTDs in INT. 3h — Three PTDs in INT.

Once the LastPTD bit corresponding to a PTD is set, this will be the last PTD processed (checking V = 1) in that PTD category. Subsequently, processing will restart with the first PTD of that group. This is useful to reduce the time in which all the PTDs, the respective memory space, would be checked, especially if only a few PTDs are defined.

10.1.13 ATL PTD Done Map register

[Table 43](#) shows the bit description of the ATL PTD Done Map register.

Table 43. ATL PTD Done Map register (address B0h) bit description

Legend: * reset value

Bit	Symbol	Access	Value	Description
15 to 0	ATL_PTD_DONE_MAP[15:0]	R	0000h*	ATL PTD done map: Done map for each of the 16 PTDs for the ATL transfer.

This register represents a direct map of the done status of 16 PTDs. The bit corresponding to a particular PTD will be set to logic 1 as soon as that PTD execution is completed. Reading the done map register will clear all the bits that are set to logic 1, and the next reading will reflect the updated status of the new executed PTDs.

10.1.14 ATL PTD Skip Map register

The bit description of the register is given in [Table 44](#).

Table 44. ATL PTD Skip Map register (address B2h) bit description

Legend: * reset value

Bit	Symbol	Access	Value	Description
15 to 0	ATL_PTD_SKIP_MAP[15:0]	R/W	FFFFh*	ATL PTD skip map: Skip map for each of the 16 PTDs for the ATL transfer.

When a bit in the PTD skip map is set to logic 1, that PTD will be skipped although its V bit may be set. The information in that PTD is not processed. When the PTD is in process, the software must not set this bit. After writing to this register, add 100 ns delay before reading it.

10.1.15 ATL PTD Last PTD register

The bit description of the ATL PTD Last PTD register is given in [Table 45](#).

Table 45. ATL PTD Last PTD register (address B4h) bit description

Legend: * reset value

Bit	Symbol	Access	Value	Description
15 to 0	ATL_PTD_LAST_PTD[15:0]	R/W	0000h*	ATL PTD last PTD: Last PTD of the 16 PTDs. 1h — One PTD in ATL. 2h — Two PTDs in ATL. 4h — Three PTDs in ATL.

Once the LastPTD bit corresponding to a PTD is set, this will be the last PTD processed (checking $V = 1$) in that PTD category. Subsequently, processing will restart with the first PTD of that group. This is useful to reduce the time in which all the PTDs, the respective memory space, would be checked, especially if only a few PTDs are defined.

10.2 Configuration registers

10.2.1 HW Mode Control register

[Table 46](#) shows the bit allocation of the register.

Remark: Use single-byte write access when configuring registers in NAND or NOR 8-bit mode.

Table 46. HW Mode Control - Hardware Mode Control register (address B6h) bit allocation

Bit	15	14	13	12	11	10	9	8
Symbol	reserved ^[1]			ID_PULLUP	DEV_DMA	COMN_INT	COMN_DMA	reserved ^[1]
Reset	0	0	0	0	0	0	0	0
Access	R/W	R/W	R/W	R/W	R/W	R/W	R/W	R/W
Bit	7	6	5	4	3	2	1	0
Symbol	reserved ^[1]	DACK_POL	DREQ_POL	DATA_BUS_WIDTH	INTF_LOCK	INTR_POL	INTR_LEVEL	GLOBAL_INTR_EN
Reset	0	0	0	0	0	0	0	0
Access	R/W	R/W	R/W	R/W	R/W	R/W	R/W	R/W

[1] The reserved bits should always be written with the reset value.

Table 47. HW Mode Control - Hardware Mode Control register (address B6h) bit description

Bit	Symbol	Description
15 to 13	-	reserved
12	ID_PULLUP	ID pull up: Connects a pull-up to the ID line and enables sampling of the ID level. Disabling the ID line sampler will reduce the PHY power consumption. 0 — Disable sampling of the ID line. 1 — Enable sampling of the ID line.
11	DEV_DMA	Device DMA: When this bit and bit 9 are set, DC_DREQ and DC_DACK peripheral signals are routed to the DREQ and DACK pins.
10	COMN_INT	Common INT: When this bit is set, DC_INT will be routed to the INT pin.
9	COMN_DMA	Common DMA: When this bit and bit 11 are set, the DC_DREQ and DC_DACK peripheral signals are routed to the DREQ and DACK pins.
8 to 7	-	reserved

Table 47. HW Mode Control - Hardware Mode Control register (address B6h) bit description ...continued

Bit	Symbol	Description
6	DACK_POL	<p>DACK polarity:</p> <p>1 — Indicates that the DACK input is active HIGH.</p> <p>0 — Indicates that the DACK input is active LOW.</p> <p>Remark: Value written to this bit must be the same as the value written to bit DACK_POL in the peripheral controller DMA Hardware register (address 3Ch).</p>
5	DREQ_POL	<p>DREQ polarity:</p> <p>1 — Indicates that the DREQ output is active HIGH.</p> <p>0 — Indicates that the DREQ output is active LOW.</p> <p>Remark: Value written to this bit must be the same as the value written to bit DREQ_POL in the peripheral controller DMA Hardware register (address 3Ch).</p>
4	DATA_BUS_WIDTH	<p>Data bus width:</p> <p>0 — Defines a 16-bit data bus width.</p> <p>1 — Sets a 8-bit data bus width.</p>
3	INTF_LOCK	<p>Interface lock:</p> <p>0 — Unlocks the bus interface.</p> <p>1 — Locks the bus interface.</p>
2	INTR_POL	<p>Interrupt polarity:</p> <p>0 — Active LOW</p> <p>1 — Active HIGH</p> <p>Remark: Value written to this bit must be the same as the value written to bit INTPOL in the peripheral controller Interrupt Configuration register (address 10h).</p>
1	INTR_LEVEL	<p>Interrupt level:</p> <p>0 — INT is level triggered.</p> <p>1 — INT is edge triggered. The pulse width depends on the NO_OF_CLK bits in the Edge Interrupt Count register.</p> <p>Remark: Value written to this bit must be the same as the value written to bit INTLVL in the peripheral controller Interrupt Configuration register (address 10h).</p>
0	GLOBAL_INTR_EN	<p>Global interrupt enable: This bit must be set to logic 1 to enable INT signal assertion.</p> <p>0 — INT assertion disabled. INT will never be asserted, regardless of other settings or INT events.</p> <p>1 — INT assertion enabled. INT will be asserted according to the HcInterruptEnable register, and event setting and occurrence.</p>

10.2.2 SW Reset register

[Table 48](#) shows the bit allocation of the register.

Table 48. SW Reset - Software Reset register (address B8h) bit allocation

Bit	15	14	13	12	11	10	9	8
Symbol	reserved ^[1]							
Reset	0	0	0	0	0	0	0	0
Access	R/W	R/W	R/W	R/W	R/W	R/W	R/W	R/W

Bit	7	6	5	4	3	2	1	0
Symbol	INTF_MODE[1:0]		reserved ^[1]		RESET_ATX	reserved ^[1]	RESET_HC	RESET_ALL
Reset	0	0	0	0	0	0	0	0
Access	R	R	R/W	R/W	R/W	R/W	R/W	R/W

[1] The reserved bits should always be written with the reset value.

Table 49. SW Reset - Software Reset register (address B8h) bit description

Bit	Symbol	Description
15 to 8	-	reserved
7 to 6	INTF_MODE[1:0]	Interface mode: When read: 00b — NAND mode 01b — Generic mode 10b — NOR mode 11b — SRAM mode Writing to these bits have no effect.
5 to 4	-	reserved
3	RESET_ATX	Reset ATX: Reset both transceivers. 0 — No reset 1 — Enable reset Remark: Writing logic 1 followed by logic 0 will enable the software reset to ATX.
2	-	reserved
1	RESET_HC	Reset host controller: Reset only host controller-specific registers. 0 — No reset 1 — Enable reset
0	RESET_ALL	Reset all: Reset all host controller and CPU interface registers. 0 — No reset 1 — Enable reset

10.2.3 HcBufferStatus register

The HcBufferStatus register is used to indicate to the host controller that a particular PTD buffer (that is, ATL, INT, or ISO) contains at least one PTD that must be scheduled. Once the software sets the Buffer Filled bit of a particular transfer in the HcBufferStatus register, the host controller will start traversing through the PTD headers that are valid PTDs and not marked for skipping.

Remark: The software can set these bits during the initialization.

[Table 50](#) shows the bit allocation of the HcBufferStatus register.

Table 50. HcBufferStatus - Host Controller Buffer Status register (address BAh) bit allocation

Bit	15	14	13	12	11	10	9	8
Symbol					reserved ^[1]			
Reset	0	0	0	0	0	0	0	0
Access	R/W	R/W	R/W	R/W	R/W	R/W	R/W	R/W

Bit	7	6	5	4	3	2	1	0
Symbol	reserved ^[1]					ISO_BUF_ FILL	INT_BUF_ FILL	ATL_BUF_ FILL
Reset	0	0	0	0	0	0	0	0
Access	R/W	R/W	R/W	R/W	R/W	R/W	R/W	R/W

[1] The reserved bits should always be written with the reset value.

Table 51. HcBufferStatus - Host Controller Buffer Status register (address BAh) bit description

Bit	Symbol	Description
15 to 3	-	reserved
2	ISO_BUF_ FILL	ISO buffer filled: 1 — Indicates one of the ISO PTDs is filled, and the ISO PTD area will be processed. 0 — Indicates there is no PTD in this area. Therefore, processing of ISO PTDs will be completely skipped.
1	INT_BUF_ FILL	INT buffer filled: 1 — Indicates one of the INT PTDs is filled, and the INT PTD area will be processed. 0 — Indicates there is no PTD in this area. Therefore, processing of INT PTDs will be completely skipped.
0	ATL_BUF_ FILL	ATL buffer filled: 1 — Indicates one of the ATL PTDs is filled, and the ATL PTD area will be processed. 0 — Indicates there is no PTD in this area. Therefore, processing of ATL PTDs will be completely skipped.

10.2.4 HcDMAConfiguration register

The bit allocation of the HcDMAConfiguration register is given in [Table 52](#).

Table 52. HcDMAConfiguration - Host Controller Direct Memory Access Configuration register (address BCh) bit allocation

Bit	31	30	29	28	27	26	25	24
Symbol	DMA_COUNTER[23:16]							
Reset	0	0	0	0	0	0	0	0
Access	R/W	R/W	R/W	R/W	R/W	R/W	R/W	R/W
Bit	23	22	21	20	19	18	17	16
Symbol	DMA_COUNTER[15:8]							
Reset	0	0	0	0	0	0	0	0
Access	R/W	R/W	R/W	R/W	R/W	R/W	R/W	R/W
Bit	15	14	13	12	11	10	9	8
Symbol	DMA_COUNTER[7:0]							
Reset	0	0	0	0	0	0	0	0
Access	R/W	R/W	R/W	R/W	R/W	R/W	R/W	R/W

Bit	7	6	5	4	3	2	1	0
Symbol	DIS_DMA_DATA_PORT	reserved ^[1]			BURST_LEN[1:0]		ENABLE_DMA	DMA_READ_WRITE_SEL
Reset	0	0	0	0	0	0	0	0
Access	R/W	R/W	R/W	R/W	R/W	R/W	R/W	R/W

[1] The reserved bits should always be written with the reset value.

Table 53. HcDMAConfiguration - Host Controller Direct Memory Access Configuration register (address BCh) bit description

Bit	Symbol	Description
31 to 8	DMA_COUNTER [23:0]	DMA counter: The number of bytes to be transferred (read or write). Remark: Different number of bursts will be generated for the same transfer length programmed in 8-bit and 16-bit modes because DMA_COUNTER is in number of bytes.
7	DIS_DMA_DATA_PORT	Disable DMA data port: 0 — Enable DMA data port. 1 — Disable DMA data port.
6 to 4	-	reserved
3 to 2	BURST_LEN[1:0]	DMA burst length: 00 — Single DMA burst 01 — 4-cycle DMA burst 10 — 8-cycle DMA burst 11 — 16-cycle DMA burst
1	ENABLE_DMA	Enable DMA: 0 — Terminate DMA 1 — Enable DMA
0	DMA_READ_WRITE_SEL	DMA read or write select: Indicates if the DMA operation is a write to or read from the ISP1763A. 0 — DMA write to the ISP1763A internal RAM. 1 — DMA read from the ISP1763A internal RAM.

10.2.5 ATL Done Timeout register

The bit description of the ATL Done Timeout register is given in [Table 54](#).

Table 54. ATL Done Timeout register (address: C0h) bit description

Legend: * reset value

Bit	Symbol	Access	Value	Description
31 to 0	ATL_DONE_TIMEOUT [31:0]	R/W	0000 0000h*	ATL done timeout: This register determines the ATL done time-out interrupt. This register defines the time-out in seconds after which the ISP1763A asserts the INT line, if enabled. It is applicable to ATL done PTDs only.

10.2.6 Memory register

The Memory register contains the base memory read or write address. This register must be set only before a first memory read cycle. Once written, the address will be latched and will be incremented for every read until a new address is written to change the address pointer.

The bit description of the register is given in [Table 55](#).

Table 55. Memory register (address C4h) bit allocation

Bit	15	14	13	12	11	10	9	8
Symbol	START_ADDR_MEM[15:8]							
Reset	0	0	0	0	0	0	0	0
Access	R/W	R/W	R/W	R/W	R/W	R/W	R/W	R/W
Bit	7	6	5	4	3	2	1	0
Symbol	START_ADDR_MEM[7:0]							
Reset	0	0	0	0	0	0	0	0
Access	R/W	R/W	R/W	R/W	R/W	R/W	R/W	R/W

Table 56. Memory register (address C4h) bit description

Bit	Symbol	Description
15 to 0	START_ADDR_MEM[15:0]	Start address for memory read or write cycles: The start address for a series of memory read or write cycles at incremental addresses in a contiguous space.

10.2.7 Data Port register

[Table 57](#) shows the bit description of this register.

Table 57. Data Port register (address: C6h) bit description

Legend: * reset value

Bit	Symbol	Access	Value	Description
15 to 0	DATA_PORT[15:0]	R/W	0000h*	Data port: This register is used to access the host controller memory.

10.2.8 Edge Interrupt Count register

[Table 58](#) shows the bit allocation of the register.

Table 58. Edge Interrupt Count register (address C8h) bit allocation

Bit	31	30	29	28	27	26	25	24
Symbol	MIN_WIDTH[7:0]							
Reset	0	0	0	0	0	0	0	0
Access	R/W	R/W	R/W	R/W	R/W	R/W	R/W	R/W
Bit	23	22	21	20	19	18	17	16
Symbol	reserved ^[1]							
Reset	0	0	0	0	0	0	0	0
Access	R/W	R/W	R/W	R/W	R/W	R/W	R/W	R/W
Bit	15	14	13	12	11	10	9	8
Symbol	NO_OF_CLK[15:8]							
Reset	0	0	0	0	0	0	0	0
Access	R/W	R/W	R/W	R/W	R/W	R/W	R/W	R/W
Bit	7	6	5	4	3	2	1	0
Symbol	NO_OF_CLK[7:0]							
Reset	0	0	0	0	1	1	1	1
Access	R/W	R/W	R/W	R/W	R/W	R/W	R/W	R/W

[1] The reserved bits should always be written with the reset value.

Table 59. Edge Interrupt Count register (address C8h) bit description

Bit	Symbol	Description
31 to 24	MIN_WIDTH [7:0]	Minimum width: Indicates the minimum width between two edge interrupts in μ SOFs (1 μ SOF = 125 μ s). This is not valid for level interrupts. A count of zero means that an interrupt occurs as and when an event occurs.
23 to 16	-	reserved
15 to 0	NO_OF_CLK[15:0]	Number of clocks: Number of clocks that the edge interrupt must be kept asserted on the interface. 15 clocks of 30 MHz on POR if this register has a value of 000Fh. The default INT pulse width is approximately 500 ns. Zero is an invalid setting for these bits.

10.2.9 DMA Data Port register

[Table 60](#) for the bit description of the DMA Data Port register.

Table 60. DMA Data Port register (address 60h) bit description

Bit	Symbol	Access	Value	Description
15 to 0	DMA_DATA_PORT[15:0]	R/W	-	DMA data port: Access the memory through DMA.

10.2.10 DMA Start Address register

This register defines the start address select for the DMA read and write operations. See [Table 61](#) for bit description.

Table 61. DMA Start Address register (address CCh) bit description

Legend: * reset value

Bit	Symbol	Access	Value	Description
15 to 0	START_ADDR_DMA[15:0]	W	0000h*	Start address for DMA: The start address for DMA read or write cycles.

10.2.11 Power Down Control register

This register is used to turn off power to internal blocks of the ISP1763A to obtain maximum power savings. [Table 62](#) shows the bit allocation of the register.

Table 62. Power Down Control register (address D0h) bit allocation

Bit	31	30	29	28	27	26	25	24
Symbol	CLK_OFF_COUNTER[15:8]							
Reset	0	0	0	0	0	0	1	1
Access	R/W	R/W	R/W	R/W	R/W	R/W	R/W	R/W
Bit	23	22	21	20	19	18	17	16
Symbol	CLK_OFF_COUNTER[7:0]							
Reset	1	1	1	0	1	0	0	0
Access	R/W	R/W	R/W	R/W	R/W	R/W	R/W	R/W
Bit	15	14	13	12	11	10	9	8
Symbol	P2_FORCE_FS	P1_FORCE_FS	reserved ^[1]		PORT2_PD	reserved ^[1]	P2_OC_EN	P1_OC_EN
Reset	0	0	0	1	1	0	1	1
Access	R/W	R/W	R/W	R/W	R/W	R/W	R/W	R/W

Bit	7	6	5	4	3	2	1	0
Symbol	ATX2_PWRON	reserved ^[1]	REG_PWR	REG_SUSP_PWR	reserved ^[1]	P2_OTG_EN	P1_OTG_EN	HC_CLK_EN
Reset	1	0	1	0	0	0	0	0
Access	R/W	R/W	R/W	R/W	R/W	R/W	R/W	R/W

[1] The reserved bits should always be written with the reset value.

Table 63. Power Down Control register (address D0h) bit description

Bit	Symbol	Description
31 to 16	CLK_OFF_COUNTER[15:0]	Clock off counter: Determines the wake-up status duration after any wake-up event before the ISP1763A goes back into suspend mode. This time-out is applicable only if, during the given interval, the host controller is not programmed back to the normal functionality. The setting of this register is based on the LazyClock frequency.
15	P2_FORCE_FS	Port 2 force full-speed: 0 — Port 2 is not forced into full-speed. 1 — Force port 2 into full-speed.
14	P1_FORCE_FS	Port 1 force full-speed: 0 — Port 1 is not forced into full-speed. 1 — Force port 1 into full-speed.
13 to 12	-	reserved
11	PORT2_PD	Port 2 pull-down: Controls port 2 pull-down resistors. 0 — Port 2 internal pull-down resistors are not connected. 1 — Port 2 internal pull-down resistors are connected.
10	-	reserved
9	P2_OC_EN	Port 2 overcurrent enable: 0 — Disable overcurrent on port 2. 1 — Enable overcurrent on port 2.
8	P1_OC_EN	Port 1 overcurrent enable: 0 — Disable overcurrent on port 1. 1 — Enable overcurrent on port 1.
7	ATX2_PWRON	ATX2 power on: Controls the ATX2 suspend. 0 — ATX2 is suspended. ATX2 macrocell is in suspend mode that draws minimal power from supplies. 1 — ATX2 is in normal operational mode. ATX2 macrocell draws normal current.
6	-	reserved
5	REG_PWR	Regulator powered: Controls the power-down mode. 0 — The device is set to power-down mode. Output of the regulator is shut down. The digital core has no power supply. The device can be woken up by a dummy read from the PIO interface. 1 — The regulator is in normal or suspend mode.
4	REG_SUSP_PWR	Regulator suspend circuit powered: Controls regulator suspend. 0 — The regulator is in normal or power-down mode. 1 — The regulator is in suspend mode. The digital core can draw limited current from the regulator.
3	-	reserved

Table 63. Power Down Control register (address D0h) bit description ...continued

Bit	Symbol	Description
2	P2_OTG_EN	<p>Port 2 OTG comparators enable: Controls the OTG detection for port 2.</p> <p>0 — ATX OTG detection is powered off.</p> <p>1 — ATX OTG detection is powered on.</p> <p>Port 2 works with host mode only. This bit helps to detect DP asserted (DP2_SRP) and A-session valid for the A-device (A2_SESS_VLD).</p>
1	P1_OTG_EN	<p>Port 1 OTG comparators enable: Controls the OTG detection for port 1.</p> <p>0 — ATX OTG detection is powered off. V_{BUS} detection is still on for device mode.</p> <p>1 — ATX OTG detection is powered on.</p> <p>In device mode, to reduce power consumption, the OTG detection can be switched off. An independent circuit will assist port 1 to sense polarity changes on V_{BUS}.</p>
0	HC_CLK_EN	<p>Host controller clock enabled: Controls internal clocks during suspend.</p> <p>0 — Clocks are disabled during suspend. This is the default value. Only the LazyClock of 100 kHz will be left running in suspend if this bit is logic 0. If clocks are stopped during suspend, CLKREADY INT will be generated when all clocks are running stable.</p> <p>1 — All clocks are enabled even in suspend.</p>

10.3 Interrupt registers

10.3.1 HcInterrupt register

The bits of this register indicate the interrupt source, defining the events that determined the INT generation. Clearing the bits that were set because of the events listed is done by writing back logic 1 to the respective position. All bits must be reset before enabling new interrupt events. These bits will be set, regardless of the setting of bit GLOBAL_INTR_EN in the HW Mode Control register. [Table 64](#) shows the bit allocation of the HcInterrupt register.

Table 64. HcInterrupt - Host Controller Interrupt register (address D4h) bit description

Bit	15	14	13	12	11	10	9	8
Symbol	reserved ^[1]					OTG_IRQ	ISO_IRQ	ATL_IRQ
Reset	0	0	0	0	0	0	0	0
Access	R/W	R/W	R/W	R/W	R/W	R/W	R/W	R/W
Bit	7	6	5	4	3	2	1	0
Symbol	INT_IRQ	CLK READY	HCSUSP	OPR_REG	DMAEOT INT	reserved ^[1]	SOFINT	MSOFINT
Reset	0	1	0	0	0	0	0	0
Access	R/W	R/W	R/W	R/W	R/W	R/W	R/W	R/W

[1] The reserved bits should always be written with the reset value.

Table 65. HcInterrupt - Host Controller Interrupt register (address D4h) bit description

Bit	Symbol	Description
15 to 11	-	reserved
10	OTG_IRQ	<p>OTG IRQ: Indicates that an OTG event occurred. The INT line will be asserted if the respective enable bit in the HcInterruptEnable register is set.</p> <p>0 — No OTG event. 1 — OTG event occurred.</p> <p>For details, see Section 8.9.3.</p>
9	ISO_IRQ	<p>ISO IRQ: Indicates that an ISO PTD was completed, or the PTDs corresponding to the bits set in the ISO IRQ MASK AND or ISO IRQ MASK OR register bits combination were completed. The INT line will be asserted if the respective enable bit in the HcInterruptEnable register is set.</p> <p>0 — No ISO PTD event occurred. 1 — ISO PTD event occurred.</p> <p>For details, see Section 8.9.3.</p>
8	ATL_IRQ	<p>ATL IRQ: Indicates that an ATL PTD was completed, or the PTDs corresponding to the bits set in the ATL IRQ MASK AND or ATL IRQ MASK OR register bits combination were completed. The INT line will be asserted if the respective enable bit in the HcInterruptEnable register is set.</p> <p>0 — No ATL PTD event occurred. 1 — ATL PTD event occurred.</p> <p>For details, see Section 8.9.3.</p>
7	INT_IRQ	<p>INT IRQ: Indicates that an INT PTD was completed, or the PTDs corresponding to the bits set in the INT IRQ MASK AND or INT IRQ MASK OR register bits combination were completed. The INT line will be asserted if the respective enable bit in the HcInterruptEnable register is set.</p> <p>0 — No INT PTD event occurred. 1 — INT PTD event occurred.</p> <p>For details, see Section 8.9.3.</p>
6	CLKREADY	<p>Clock ready: Indicates that internal clock signals are running stable. The INT line will be asserted if the respective enable bit in the HcInterruptEnable register is set.</p> <p>0 — No CLKREADY event has occurred. 1 — CLKREADY event occurred.</p>
5	HCSUSP	<p>Host controller suspend: Indicates that the host controller has entered suspend mode. The INT line will be asserted if the respective enable bit in the HcInterruptEnable register is set.</p> <p>0 — The host controller did not enter suspend mode. 1 — The host controller entered suspend mode.</p> <p>If the Interrupt Service Routine (ISR) accesses the ISP1763A, it will wake up for the time specified in bits 31 to 16 of the Power Down Control register.</p>

Table 65. HcInterrupt - Host Controller Interrupt register (address D4h) bit description ...continued

Bit	Symbol	Description
4	OPR_REG	Operational registers: Indicates an INT was generated because of at least one change in operational registers. 0 — No INT because of operational registers change. 1 — INT generated because of at least one change in operational registers.
3	DMAEOT INT	DMA EOT interrupt: Indicates the DMA transfer completion. The INT line will be asserted if the respective enable bit in the HcInterruptEnable register is set. 0 — No DMA transfer is completed. 1 — DMA transfer is completed.
2	-	reserved; value is zero just after reset and changes to one after a short while
1	SOFINT	SOF interrupt: The INT line will be asserted if the respective enable bit in the HcInterruptEnable register is set. 0 — No SOF event has occurred. 1 — SOF event has occurred.
0	MSOFINT	μSOF ITL interrupt: The INT line will be asserted if the respective enable bit in the HcInterruptEnable register is set. 0 — No μSOF event has occurred. 1 — μSOF event has occurred.

10.3.2 HcInterruptEnable register

This register allows enabling or disabling of the INT generation because of various events as described in [Table 66](#).

Table 66. HcInterruptEnable - Host Controller Interrupt Enable register (address D6h) bit allocation

Bit	15	14	13	12	11	10	9	8
Symbol	reserved ^[1]					OTG_IRQ_ E	ISO_IRQ_ E	ATL_IRQ_ E
Reset	0	0	0	0	0	0	0	0
Access	R/W	R/W	R/W	R/W	R/W	R/W	R/W	R/W
Bit	7	6	5	4	3	2	1	0
Symbol	INT_IRQ_ E	CLK READY_ E	HCSUSP_ E	OPR_REG _E	DMAEOT INT_ E	reserved ^[1]	SOFINT _E	MSOFINT _E
Reset	0	0	0	0	0	0	0	0
Access	R/W	R/W	R/W	R/W	R/W	R/W	R/W	R/W

[1] The reserved bits should always be written with the reset value.

Table 67. HcInterruptEnable - Host Controller Interrupt Enable register (address D6h) bit description

Bit	Symbol	Description
15 to 11	-	reserved
10	OTG_IRQ_E	<p>OTG IRQ enable: Controls the INT assertion because of events present in the OTG Interrupt Latch register.</p> <p>0 — No INT will be asserted.</p> <p>1 — INT will be asserted.</p> <p>For details, see Section 8.9.3.</p>
9	ISO_IRQ_E	<p>ISO IRQ enable: Controls the INT assertion when one or more ISO PTDs matching the ISO IRQ Mask AND or ISO IRQ Mask OR register bits combination are completed.</p> <p>0 — No INT will be asserted when ISO PTDs are completed.</p> <p>1 — INT will be asserted.</p> <p>For details, see Section 8.9.3.</p>
8	ATL_IRQ_E	<p>ATL IRQ enable: Controls the INT assertion when one or more ATL PTDs matching the ATL IRQ Mask AND or ATL IRQ Mask OR register bits combination are completed.</p> <p>0 — No INT will be asserted when ATL PTDs are completed.</p> <p>1 — INT will be asserted.</p> <p>For details, see Section 8.9.3.</p>
7	INT_IRQ_E	<p>INT IRQ enable: Controls the INT assertion when one or more INT PTDs matching the INT IRQ Mask AND or INT IRQ Mask OR register bits combination are completed.</p> <p>0 — No INT will be asserted when INT PTDs are completed.</p> <p>1 — INT will be asserted.</p> <p>For details, see Section 8.9.3.</p>
6	CLKREADY_E	<p>Clock ready enable: Enables the INT assertion when internal clock signals are running stable. Useful after wake-up.</p> <p>0 — No INT will be generated after CLKREADY_E event.</p> <p>1 — INT will be generated after a CLKREADY_E event.</p>
5	HCSUSP_E	<p>Host controller suspend enable: Enables the INT generation when the host controller enters suspend mode.</p> <p>0 — No INT will be generated when the host controller enters suspend mode.</p> <p>1 — INT will be generated when the host controller enters suspend mode.</p>
4	OPR_REG_E	<p>Operational registers enable: Controls the INT generation because of at least one change in operational registers.</p> <p>0 — No INT will be generated on any change in operational registers.</p> <p>1 — INT will be generated after a bit change, set by the software or hardware internally modified by the host controller, in the operational registers.</p>
3	DMAEOT INT_E	<p>DMA EOT interrupt enable: Controls assertion of INT on the DMA transfer completion.</p> <p>0 — No INT will be generated when a DMA transfer is completed.</p> <p>1 — INT will be asserted when a DMA transfer is completed.</p>
2	-	reserved
1	SOFINT_E	<p>SOF interrupt enable: Controls the INT generation at every SOF occurrence.</p> <p>0 — No INT will be generated on SOF occurrence.</p> <p>1 — INT will be asserted at every SOF.</p>
0	MSOFINT_E	<p>μSOF interrupt enable: Controls the INT generation at every μSOF occurrence.</p> <p>0 — No INT will be generated on μSOF occurrence.</p> <p>1 — INT will be asserted at every μSOF.</p>

10.3.3 ISO IRQ MASK OR register

Each bit of this register corresponds to one of the 16 ISO PTDs defined, and is a hardware INT mask for each PTD done map. See [Table 68](#) for the bit description.

Table 68. ISO IRQ MASK OR register (address D8h) bit description

Legend: * reset value

Bit	Symbol	Access	Value	Description
15 to 0	ISO_IRQ_MASK_OR[15:0]	R/W	0000h*	ISO IRQ mask OR: Represents a direct map for ISO PTDs 15 to 0. 0 — No OR condition defined between ISO PTDs 1 — The bits corresponding to certain PTDs are set to logic 1 to define a certain OR condition

10.3.4 INT IRQ MASK OR register

Each bit of this register (see [Table 69](#)) corresponds to one of the 16 INT PTDs defined, and is a hardware INT mask for each PTD done map.

Table 69. INT IRQ MASK OR register (address DAh) bit description

Legend: * reset value

Bit	Symbol	Access	Value	Description
15 to 0	INT_IRQ_MASK_OR[15:0]	R/W	0000h*	INT IRQ mask OR: Represents a direct map for INT PTDs 15 to 0. 0 — No OR condition defined between INT PTDs 15 to 0. 1 — The bits corresponding to certain PTDs are set to logic 1 to define a certain OR condition.

10.3.5 ATL IRQ MASK OR register

Each bit of this register corresponds to one of the 16 ATL PTDs defined, and is a hardware INT mask for each PTD done map. See [Table 70](#) for the bit description.

Table 70. ATL IRQ MASK OR register (address DCh) bit description

Legend: * reset value

Bit	Symbol	Access	Value	Description
15 to 0	ATL_IRQ_MASK_OR[15:0]	R/W	0000h*	ATL IRQ mask OR: Represents a direct map for ATL PTDs 15 to 0. 0 — No OR condition defined between ATL PTDs. 1 — The bits corresponding to certain PTDs are set to logic 1 to define a certain OR condition.

10.3.6 ISO IRQ MASK AND register

Each bit of this register corresponds to one of the 16 ISO PTDs defined, and is a hardware INT mask for each PTD done map. See [Table 71](#) for the bit description.

Table 71. ISO IRQ MASK AND register (address DEh) bit description

Legend: * reset value

Bit	Symbol	Access	Value	Description
15 to 0	ISO_IRQ_MASK_AND[15:0]	R/W	0000h*	ISO IRQ mask AND: Represents a direct map for ISO PTDs 15 to 0. 0 — No AND condition defined between ISO PTDs. 1 — The bits corresponding to certain PTDs are set to logic 1 to define a certain AND condition between 16 INT PTDs.

10.3.7 INT IRQ MASK AND register

Each bit of this register (see [Table 72](#)) corresponds to one of the 16 INT PTDs defined, and is a hardware INT mask for each PTD done map.

Table 72. INT IRQ MASK AND register (address E0h) bit description

Legend: * reset value

Bit	Symbol	Access	Value	Description
15 to 0	INT_IRQ_MASK_AND [15:0]	R/W	0000h*	INT IRQ mask AND: Represents a direct map for INT PTDs 15 to 0. 0 — No OR condition defined between INT PTDs. 1 — The bits corresponding to certain PTDs are set to logic 1 to define a certain AND condition between 16 INT PTDs.

10.3.8 ATL IRQ MASK AND register

Each bit of this register corresponds to one of the 16 ATL PTDs defined, and is a hardware INT mask for each PTD done map. See [Table 73](#) for the bit description.

Table 73. ATL IRQ MASK AND register (address E2h) bit description

Legend: * reset value

Bit	Symbol	Access	Value	Description
15 to 0	ATL_IRQ_MASK_AND [15:0]	R/W	0000h*	INT IRQ mask AND: Represents a direct map for ATL PTDs 15 to 0. 0 — No OR condition defined between ATL PTDs. 1 — The bits corresponding to certain PTDs are set to logic 1 to define a certain AND condition between 16 ATL PTDs.

10.4 Proprietary Transfer Descriptor (PTD)

The standard EHCI data structures as described in *Enhanced Host Controller Interface Specification for Universal Serial Bus Rev. 1.0* are optimized for the bus master operation that is managed by the hardware state machine.

The PTD structures of the ISP1763A are translations of EHCI data structures that are optimized for the ISP1763A. They, however, still follow the basic EHCI architecture. This optimized form of EHCI data structures is necessary because the ISP1763A is a slave host controller and has no bus master capability.

EHCI manages schedules in two lists: periodic and asynchronous. Data structures are designed to provide the maximum flexibility required by USB, minimize memory traffic, and reduce hardware and software complexity. The ISP1763A controller executes transactions for devices by using a simple shared-memory schedule. This schedule consists of data structures organized into three lists.

qISO — Isochronous transfer

qINTL — Interrupt transfer

qATL — Asynchronous transfer; for the control and bulk transfers

The system software maintains two lists for the host controller: periodic and asynchronous.

The ISP1763A has a maximum of 16 ISO, 16 INTL, and 16 ATL PTDs. These PTDs are used as channels to transfer data from the shared memory to the USB bus. These channels are allocated and deallocated on receiving the transfer from the core USB driver.

Multiple transfers are scheduled to the shared memory for various endpoints by traversing the next link pointer provided by endpoint data structures, until it reaches the end of the endpoint list. There are three endpoint lists: one for ISO endpoints, and the other for INTL and ATL endpoints. If the schedule is enabled, the host controller executes the ISO schedule, followed by the INTL schedule, and then the ATL schedule.

These lists are traversed and scheduled by the software according to the EHCI traversal rule. The host controller executes scheduled ISO, INTL, and ATL PTDs. The completion of a transfer is indicated to the software by the interrupt that can be grouped under various PTDs by using the AND or OR registers that are available for each schedule type: ISO, INTL, and ATL. These registers are simple logic registers to decide the completion status of group and individual PTDs. When the logical conditions of the done bit are true in the shared memory, it means that PTD has completed.

There are four types of interrupts in the ISP1763A: ISO, INTL, ATL, and SOF. The latency can be programmed in multiples of μ SOF (125 μ s).

10.4.1 High-speed bulk IN and OUT

Table 74 shows the bit allocation of the high-speed bulk IN and OUT, asynchronous Transfer Descriptor.

Table 74. High-speed bulk IN and OUT: bit allocation

Bit	63	62	61	60	59	58	57	56	55	54	53	52	51	50	49	48	47	46	45	44	43	42	41	40	39	38	37	36	35	34	33	32
DW7	reserved																															
DW5	reserved																															
DW3	A	H	B	X	[1]	P	DT	Cerr [1:0]	NakCnt[3:0]			reserved			NrBytesTransferred[14:0] (1 B to 20 kB for high-speed)																	
DW1	reserved													S	EPTyp [1:0]	Token [1:0]	DeviceAddress[6:0]						EndPt[3:0]									
Bit	31	30	29	28	27	26	25	24	23	22	21	20	19	18	17	16	15	14	13	12	11	10	9	8	7	6	5	4	3	2	1	0
DW6	reserved																															
DW4	reserved																															
DW2	reserved		RL[3:0]			[1]	DataStartAddress[15:0]													reserved												
DW0	[2]	Mult [1:0]		MaxPacketLength[10:0]										NrBytesToTransfer[14:0]														[1]	V			

[1] Reserved.

[2] EndPt[0].

Table 75. High-speed bulk IN and OUT: bit description

Bit	Symbol	Access	Value	Description
DW7				
63 to 32	reserved	-	-	-
DW6				
31 to 0	reserved	-	-	-
DW5				
63 to 32	reserved	-	-	-
DW4				
31 to 0	reserved	-	0	Not applicable for asynchronous TD.
DW3				
63	A	SW — sets HW — resets	-	Active: Write the same value as that in V.
62	H	HW — writes	-	Halt: This bit corresponds to the Halt bit of the Status field of TD.
61	B	HW — writes	-	Babble: This bit corresponds to the Babble Detected bit in the Status field of iTD, siTD, or TD. 1 — When babbling is detected, A and V are set to 0.
60	X	HW — writes	-	Error: This bit corresponds to the Transaction Error bit in the Status field of iTD, siTD, or TD (Exec_Trans, the signal name is xacterr). 0 — No PID error. 1 — If there are PID errors, this bit is set to active. The A and V bits are also set to inactive. This transaction is retried three times.
		SW — writes	-	0 — Before scheduling.
59	reserved	-	-	-
58	P	SW — writes HW — updates	-	Ping: For high-speed transactions, this bit corresponds to the Ping state bit in the Status field of a TD. 0 — Ping is not set. 1 — Ping is set. For the first time, the software sets the Ping bit to 0. For the successive asynchronous TD, the software sets the bit in asynchronous TD based on the state of the bit for the previous asynchronous TD of the same transfer, that is: <ul style="list-style-type: none"> • The current asynchronous TD is completed with the Ping bit set. • The next asynchronous TD will have its Ping bit set by the software.
57	DT	HW — updates SW — writes	-	Data toggle: This bit is filled by the software to start a PTD. If NrBytesToTransfer[14:0] is not complete, the software needs to read this value and then write back the same value to continue.
56 to 55	Cerr[1:0]	HW — writes SW — writes	-	Error counter: This field corresponds to the Cerr[1:0] field in TD. The default value of this field is zero for isochronous transactions. 00 — The transaction will not retry. 11 — The transaction will retry three times. The hardware will decrement these values.

Table 75. High-speed bulk IN and OUT: bit description ...continued

Bit	Symbol	Access	Value	Description
54 to 51	NakCnt[3:0]	HW — writes SW — writes	-	NAK counter: This field corresponds to the NakCnt field in TD. The software writes for the initial PTD launch. The V bit is reset if NakCnt decrements to zero and RL is a non-zero value. It reloads from RL if transaction is ACK-ed.
50 to 47	reserved	-	-	-
46 to 32	NrBytes Transferred [14:0]	HW — writes SW — writes 0000	-	Number of bytes transferred: This field indicates the number of bytes sent or received for this transaction. If Mult[1:0] is greater than one, it is possible to store intermediate results in this field.
DW2				
31 to 29	reserved	-	-	Set to 0 for asynchronous TD.
28 to 25	RL[3:0]	SW — writes	-	Reload: If RL[3:0] is set to 0h, the hardware ignores the NakCnt[3:0] value. RL[3:0] and NakCnt[3:0] are set to the same value before a transaction.
24	reserved	-	-	Always 0 for asynchronous TD.
23 to 8	DataStart Address[15:0]	SW — writes	-	Data start address: This is the start address for data that will be sent on or received from the USB bus. This is the internal memory address and not the direct CPU address. RAM address = (CPU address – 400h) / 8
7 to 0	reserved	-	-	-
DW1				
63 to 47	reserved	-	-	Always 0 for asynchronous TD.
46	S	SW — writes	-	Split: This bit indicates whether a split transaction has to be executed: 0 — High-speed transaction 1 — Split transaction
45 to 44	EPTyep[1:0]	SW — writes	-	Transaction type: 00 — Control 10 — Bulk
43 to 42	Token[1:0]	SW — writes	-	Token: Identifies the token Packet Identifier (PID) for this transaction: 00 — OUT 01 — IN 10 — SETUP 11 — PING (written by the hardware only)
41 to 35	DeviceAddress [6:0]	SW — writes	-	Device address: This is the USB address of the function containing the endpoint that is referred to by this buffer.
34 to 32	EndPt[3:1]	SW — writes	-	Endpoint: This is the USB address of the endpoint within the function.
DW0				
31	EndPt[0]	SW — writes	-	Endpoint: This is the USB address of the endpoint within the function.
30 to 29	Mult[1:0]	SW — writes	-	Multiplier: This field is a multiplier used by the host controller as the number of successive packets the host controller may submit to the endpoint in the current execution. Set this field to 01b. You can also set it to 11b and 10b depending on your application. 00b is undefined.

Table 75. High-speed bulk IN and OUT: bit description ...continued

Bit	Symbol	Access	Value	Description
28 to 18	MaxPacketLength[10:0]	SW — writes	-	Maximum packet length: This field indicates the maximum number of bytes that can be sent to or received from an endpoint in a single data packet. The maximum packet size for a bulk transfer is 512 bytes. The maximum packet size for the isochronous transfer is also variable at any whole number.
17 to 3	NrBytesToTransfer[14:0]	SW — writes	-	Number of bytes to transfer: This field indicates the number of bytes that can be transferred by this data structure. It is used to indicate the depth of the data field (1 B to 20 kB).
2 to 1	reserved	-	-	-
0	V	SW — sets HW — resets	-	Valid: 0 — This bit is deactivated when the entire PTD is executed, or when a fatal error is encountered. 1 — The software updates to one when there is payload to be sent or received. The current PTD is active.

10.4.2 High-speed isochronous IN and OUT

[Table 76](#) shows the bit allocation of the high-speed isochronous IN and OUT, isochronous Transfer Descriptor (iTID).

Table 76. High-speed isochronous IN and OUT: bit allocation

Bit	63	62	61	60	59	58	57	56	55	54	53	52	51	50	49	48	47	46	45	44	43	42	41	40	39	38	37	36	35	34	33	32
DW7	ISOIN_7[11:0]											ISOIN_6[11:0]											ISOIN_5[11:4]									
DW5	ISOIN_2[7:0]							ISOIN_1[11:0]														ISOIN_0[11:0]										
DW3	A	H	B	reserved											NrBytesTransferred[14:0] (1 B to 20 kB for high-speed)																	
DW1	reserved													S	EP Type [1:0]	Token [1:0]	DeviceAddress[6:0]					EndPt[3:0]										
Bit	31	30	29	28	27	26	25	24	23	22	21	20	19	18	17	16	15	14	13	12	11	10	9	8	7	6	5	4	3	2	1	0
DW6	ISOIN_5[3:0]			ISOIN_4[11:0]														ISOIN_3[11:0]					ISOIN_2[11:8]									
DW4	Status7[2:0]		Status6[2:0]		Status5[2:0]		Status4[2:0]		Status3[2:0]		Status2[2:0]		Status1[2:0]		Status0[2:0]		μSA[7:0]															
DW2	reserved								DataStartAddress[15:0]														μFrame[7:0]									
DW0	[2]	Mult [1:0]		MaxPacketLength[10:0]											NrBytesToTransfer[14:0]														[1]	V		

[1] Reserved.

[2] EndPt[0].

Table 77. High-speed isochronous IN and OUT: bit description

Bit	Symbol	Access	Value	Description
DW7				
63 to 52	ISOIN_7[11:0]	HW — writes	-	Isochronous IN 7: Bytes received during μ SOF7, if μ SA[7] is set to 1 and frame number is correct.
51 to 40	ISOIN_6[11:0]	HW — writes	-	Isochronous IN 6: Bytes received during μ SOF6, if μ SA[6] is set to 1 and frame number is correct.
39 to 32	ISOIN_5[11:4]	HW — writes	-	Isochronous IN 5: Bytes received during μ SOF5 (bits 11 to 4), if μ SA[5] is set to 1 and frame number is correct.
DW6				
31 to 28	ISOIN_5[3:0]	HW — writes	-	Isochronous IN 5: Bytes received during μ SOF5 (bits 3 to 0), if μ SA[5] is set to 1 and frame number is correct.
27 to 16	ISOIN_4[11:0]	HW — writes	-	Isochronous IN 4: Bytes received during μ SOF4, if μ SA[4] is set to 1 and frame number is correct.
15 to 4	ISOIN_3[11:0]	HW — writes	-	Isochronous IN 3: Bytes received during μ SOF3, if μ SA[3] is set to 1 and frame number is correct.
3 to 0	ISOIN_2[11:8]	HW — writes	-	Isochronous IN 2: Bytes received during μ SOF2 (bits 11 to 8), if μ SA[2] is set to 1 and frame number is correct.
DW5				
63 to 56	ISOIN_2[7:0]	HW — writes	-	Isochronous IN 2: Bytes received during μ SOF2 (bits 7 to 0), if μ SA[2] is set to 1 and frame number is correct.
55 to 44	ISOIN_1[11:0]	HW — writes	-	Isochronous IN 1: Bytes received during μ SOF1, if μ SA[1] is set to 1 and frame number is correct.
43 to 32	ISOIN_0[11:0]	HW — writes	-	Isochronous IN 0: Bytes received during μ SOF0, if μ SA[0] is set to 1 and frame number is correct.
DW4				
31 to 29	Status7[2:0]	HW — writes	-	Status 7: ISO IN or OUT status at μ SOF7
28 to 26	Status6[2:0]	HW — writes	-	Status 6: ISO IN or OUT status at μ SOF6
25 to 23	Status5[2:0]	HW — writes	-	Status 5: ISO IN or OUT status at μ SOF5
22 to 20	Status4[2:0]	HW — writes	-	Status 4: ISO IN or OUT status at μ SOF4
19 to 17	Status3[2:0]	HW — writes	-	Status 3: ISO IN or OUT status at μ SOF3
16 to 14	Status2[2:0]	HW — writes	-	Status 2: ISO IN or OUT status at μ SOF2
13 to 11	Status1[2:0]	HW — writes	-	Status 1: ISO IN or OUT status at μ SOF1
10 to 8	Status0[2:0]	HW — writes	-	Status 0: Status of the payload on the USB bus for this μ SOF after ISO has been delivered. Bit 0 — Transaction error (IN and OUT) Bit 1 — Babble (IN token only) Bit 2 — Underrun (OUT token only)
7 to 0	μ SA[7:0]	SW — writes (0 \rightarrow 1) HW — writes (1 \rightarrow 0) After processing	-	μSOF active: When the frame number of bits DW2[7:3] match the frame number of the USB bus, these bits are checked for 1 before they are sent for μ SOF. For example: If μ SA[7:0] = 1, 1, 1, 1, 1, 1, 1, 1: send ISO every μ SOF of the entire millisecond. If μ SA[7:0] = 0, 1, 0, 1, 0, 1, 0, 1: send ISO only on μ SOF0, μ SOF2, μ SOF4, and μ SOF6.
DW3				
63	A	SW — sets	-	Active: This bit is the same as the Valid bit.

Table 77. High-speed isochronous IN and OUT: bit description ...continued

Bit	Symbol	Access	Value	Description
62	H	HW — writes	-	Halt: Only one bit for the entire millisecond. When this bit is set, the Valid bit is reset. The device decides to stall an endpoint.
61	B	HW — writes	-	Babble: Not applicable here.
60 to 47	reserved	-	0	Set to 0 for isochronous.
46 to 32	NrBytes Transferred [14:0]	HW — writes	-	Number of bytes transferred: This field indicates the number of bytes sent or received for this transaction. If Mult[1:0] is greater than one, it is possible to store intermediate results in this field. NrBytesTransferred[14:0] is 1 B to 20 kB per PTD.
DW2				
31 to 24	reserved	-	0	Set to 0 for isochronous.
23 to 8	DataStart Address[15:0]	SW — writes	-	Data start address: This is the start address for data that will be sent on or received from the USB bus. This is the internal memory address and not the direct CPU address. RAM address = (CPU address – 400h) / 8
7 to 0	μFrame[7:0]	SW — writes	-	μFrame: Bits 2 to 0 — Don't care Bits 7 to 3 — Frame number that this PTD will be sent for ISO OUT or IN
DW1				
63 to 47	reserved	-	-	-
46	S	SW — writes	-	Split: This bit indicates whether a split transaction must be executed. 0 — High-speed transaction 1 — Split transaction
45 to 44	EPTYPE[1:0]	SW — writes	-	Endpoint type: 01 — Isochronous
43 to 42	Token[1:0]	SW — writes	-	Token: This field indicates the token PID for this transaction: 00 — OUT 01 — IN
41 to 35	Device Address[6:0]	SW — writes	-	Device address: This is the USB address of the function containing the endpoint that is referred to by this buffer.
34 to 32	EndPt[3:1]	SW — writes	-	Endpoint: This is the USB address of the endpoint within the function.
DW0				
31	EndPt[0]	SW — writes	-	Endpoint: This is the USB address of the endpoint within the function.
30 to 29	Mult[1:0]	SW — writes	-	Multiplier: This field is a multiplier counter used by the host controller as the number of successive packets the host controller may submit to the endpoint in the current execution. For details, refer to Appendix D of <i>Enhanced Host Controller Interface Specification for Universal Serial Bus Rev. 1.0</i> .
28 to 18	MaxPacket Length[10:0]	SW — writes	-	Maximum packet length: This field indicates the maximum number of bytes that can be sent to or received from the endpoint in a single data packet. The maximum packet size for an isochronous transfer is 1024 bytes. The maximum packet size for the isochronous transfer is also variable at any whole number.

Table 77. High-speed isochronous IN and OUT: bit description ...continued

Bit	Symbol	Access	Value	Description
17 to 3	NrBytesTo Transfer[14:0]	SW — writes	-	Number of bytes to transfer: This field indicates the number of bytes that can be transferred by this data structure. It is used to indicate the depth of the data field (1 B to 20 kB).
2 to 1	reserved	-	-	-
0	V	HW — resets SW — sets	-	Valid: 0 — This bit is deactivated when the entire PTD is executed, or when a fatal error is encountered. 1 — The software updates to one when there is payload to be sent or received. The current PTD is active.

10.4.3 High-speed interrupt IN and OUT

[Table 78](#) shows the bit allocation of the high-speed interrupt IN and OUT, periodic Transfer Descriptor (pTD).

Table 78. High-speed interrupt IN and OUT: bit allocation

Bit	63	62	61	60	59	58	57	56	55	54	53	52	51	50	49	48	47	46	45	44	43	42	41	40	39	38	37	36	35	34	33	32
DW7	INT_IN_7[11:0]											INT_IN_6[11:0]											INT_IN_5[11:4]									
DW5	INT_IN_2[7:0]							INT_IN_1[11:0]											INT_IN_0[11:0]													
DW3	A	H	reserved			DT	Cerr [1:0]	reserved							NrBytesTransferred[14:0] (1 B to 20 kB for high-speed)																	
DW1	reserved													S	EP Type [1:0]	Token [1:0]	DeviceAddress[6:0]				EndPt[3:0]											
Bit	31	30	29	28	27	26	25	24	23	22	21	20	19	18	17	16	15	14	13	12	11	10	9	8	7	6	5	4	3	2	1	0
DW6	INT_IN_5[3:0]			INT_IN_4[11:0]											INT_IN_3[11:0]											INT_IN_2[11:8]						
DW4	Status7[2:0]		Status6[2:0]		Status5[2:0]		Status4[2:0]		Status3[2:0]		Status2[2:0]		Status1[2:0]		Status0[2:0]		μSA[7:0]															
DW2	reserved							DataStartAddress[15:0]											μFrame[7:0]													
DW0	[2]	Mult [1:0]	MaxPacketLength[10:0]											NrBytesToTransfer[14:0]											[1]	V						

[1] Reserved.

[2] EndPt[0].

Table 79. High-speed interrupt IN and OUT: bit description

Bit	Symbol	Access	Value	Description
DW7				
63 to 52	INT_IN_7[11:0]	HW — writes	-	Interrupt IN 7: Bytes received during μ SOF7, if μ SA[7] is set to 1 and frame number is correct.
51 to 40	INT_IN_6[11:0]	HW — writes	-	Interrupt IN 6: Bytes received during μ SOF6, if μ SA[6] is set to 1 and frame number is correct.
39 to 32	INT_IN_5[11:4]	HW — writes	-	Interrupt IN 5: Bytes received during μ SOF5 (bits 11 to 4), if μ SA[5] is set to 1 and frame number is correct.
DW6				
31 to 28	INT_IN_5[3:0]	HW — writes	-	Interrupt IN 5: Bytes received during μ SOF5 (bits 3 to 0), if μ SA[5] is set to 1 and frame number is correct.
27 to 16	INT_IN_4[11:0]	HW — writes	-	Interrupt IN 4: Bytes received during μ SOF4, if μ SA[4] is set to 1 and frame number is correct.
15 to 4	INT_IN_3[11:0]	HW — writes	-	Interrupt IN 3: Bytes received during μ SOF3, if μ SA[3] is set to 1 and frame number is correct.
3 to 0	INT_IN_2[11:8]	HW — writes	-	Interrupt IN 2: Bytes received during μ SOF2 (bits 11 to 8), if μ SA[2] is set to 1 and frame number is correct.
DW5				
63 to 56	INT_IN_2[7:0]	HW — writes	-	Interrupt IN 2: Bytes received during μ SOF2 (bits 7 to 0), if μ SA[2] is set to 1 and frame number is correct.
55 to 44	INT_IN_1[11:0]	HW — writes	-	Interrupt IN 1: Bytes received during μ SOF1, if μ SA[1] is set to 1 and frame number is correct.
43 to 32	INT_IN_0[11:0]	HW — writes	-	Interrupt IN 0: Bytes received during μ SOF0, if μ SA[0] is set to 1 and frame number is correct.
DW4				
31 to 29	Status7[2:0]	HW — writes	-	Status 7: INT IN or OUT status of μ SOF7
28 to 26	Status6[2:0]	HW — writes	-	Status 6: INT IN or OUT status of μ SOF6
25 to 23	Status5[2:0]	HW — writes	-	Status 5: INT IN or OUT status of μ SOF5
22 to 20	Status4[2:0]	HW — writes	-	Status 4: INT IN or OUT status of μ SOF4
19 to 17	Status3[2:0]	HW — writes	-	Status 3: INT IN or OUT status of μ SOF3
16 to 14	Status2[2:0]	HW — writes	-	Status 2: INT IN or OUT status of μ SOF2
13 to 11	Status1[2:0]	HW — writes	-	Status 1: INT IN or OUT status of μ SOF1
10 to 8	Status0[2:0]	HW — writes	-	Status 0: Status of the payload on the USB bus for this μ SOF after INT has been delivered. Bit 0 — Transaction error (IN and OUT) Bit 1 — Babble (IN token only) Bit 2 — Underrun (OUT token only)
7 to 0	μ SA[7:0]	SW — writes (0 \rightarrow 1) HW — writes (1 \rightarrow 0) After processing	-	μSA[7:0]: When the frame number of bits DW2[7:3] match the frame number of the USB bus, these bits are checked for 1 before they are sent for μ SOF. For example: When μ SA[7:0] = 1, 1, 1, 1, 1, 1, 1, 1: send INT for every μ SOF of the entire millisecond. When μ SA[7:0] = 0, 1, 0, 1, 0, 1, 0, 1: send INT for μ SOF0, μ SOF2, μ SOF4, and μ SOF6. When μ SA[7:0] = 1, 0, 0, 0, 1, 0, 0, 0: send INT for every fourth μ SOF.

Table 79. High-speed interrupt IN and OUT: bit description ...continued

Bit	Symbol	Access	Value	Description
DW3				
63	A	HW — writes SW — writes	-	Active: Write the same value as that in V.
62	H	HW — writes	-	Halt: Transaction is halted.
61 to 58	reserved	-	-	-
57	DT	HW — writes SW — writes	-	Data toggle: Set the Data Toggle bit to start the PTD. The software writes the current transaction toggle value. The hardware writes the next transaction toggle value.
56 to 55	Cerr[1:0]	HW — writes SW — writes	-	Error counter: This field corresponds to the Cerr[1:0] field in TD. The default value of this field is zero for isochronous transactions.
54 to 47	reserved	-	-	-
46 to 32	NrBytes Transferred [14:0]	HW — writes	-	Number of bytes transferred: This field indicates the number of bytes sent or received for this transaction. If Mult[1:0] is greater than one, it is possible to store intermediate results in this field.
DW2				
31 to 24	reserved	-	-	-
23 to 8	DataStart Address[15:0]	SW — writes	-	Data start address: This is the start address for data that will be sent on or received from the USB bus. This is the internal memory address and not the direct CPU address. RAM address = (CPU address – 400h) / 8
7 to 0	μFrame[7:0]	SW — writes	-	μFrame: Bits 7 to 3 represent the polling rate in milliseconds. The INT polling rate is defined as $2^{(b-1)} \mu\text{SOF}$, where b is 1 to 9. When b is 1, 2, 3, or 4, use μSA to define polling because the rate is equal to or less than 1 ms. Bits 7 to 3 are set to 0. Polling checks μSA bits for μSOF rates. See Table 80 .
DW1				
63 to 47	reserved	-	-	-
46	S	SW — writes	-	Split: This bit indicates if a split transaction has to be executed: 0 — High-speed transaction 1 — Split transaction
45 to 44	EPTYPE[1:0]	SW — writes	-	Endpoint type: 11 — Interrupt
43 to 42	Token[1:0]	SW — writes	-	Token: This field indicates the token PID for this transaction: 00 — OUT 01 — IN
41 to 35	DeviceAddress [6:0]	SW — writes	-	Device address: This is the USB address of the function containing the endpoint that is referred to by the buffer.
34 to 32	EndPt[3:1]	SW — writes	-	Endpoint: This is the USB address of the endpoint within the function.
DW0				
31	EndPt[0]	SW — writes	-	Endpoint: This is the USB address of the endpoint within the function.

Table 79. High-speed interrupt IN and OUT: bit description ...continued

Bit	Symbol	Access	Value	Description
30 to 29	Mult[1:0]	SW — writes	-	<p>Multiplier: This field is a multiplier counter used by the host controller as the number of successive packets the host controller may submit to the endpoint in the current execution.</p> <p>Set this field to 01b. You can also set it to 11b and 10b depending on your application. 00b is undefined.</p>
28 to 18	MaxPacket Length[10:0]	SW — writes	-	<p>Maximum packet length: This field indicates the maximum number of bytes that can be sent to or received from the endpoint in a single data packet.</p>
17 to 3	NrBytesTo Transfer[14:0]	SW — writes	-	<p>Number of bytes to transfer: This field indicates the number of bytes that can be transferred by this data structure. It is used to indicate the depth of the data field (1 B to 20 kB).</p>
2 to 1	reserved	-	-	-
0	V	SW — sets HW — resets	-	<p>Valid:</p> <p>0 — This bit is deactivated when the entire PTD is executed, or when a fatal error is encountered.</p> <p>1 — The software updates to one when there is payload to be sent or received. The current PTD is active.</p>

Table 80. Microframe description

b	Rate	μFrame[7:3]	μSA[7:0]
1	1 μSOF	0 0000	1111 1111
2	2 μSOF	0 0000	1010 1010 or 0101 0101
3	4 μSOF	0 0000	any 2 bits set
4	1 ms	0 0000	any 1 bit set
5	2 ms	0 0001	any 1 bit set
6	4 ms	0 0010 to 0 0011	any 1 bit set
7	8 ms	0 0100 to 0 0111	any 1 bit set
8	16 ms	0 1000 to 0 1111	any 1 bit set
9	32 ms	1 0000 to 1 1111	any 1 bit set

10.4.4 Start and complete split for bulk

Table 81 shows the bit allocation of Start Split (SS) and Complete Split (CS) for bulk, asynchronous Start Split, and Complete Split (SS/CS) Transfer Descriptor.

Table 81. Start and complete split for bulk: bit allocation

Bit	63	62	61	60	59	58	57	56	55	54	53	52	51	50	49	48	47	46	45	44	43	42	41	40	39	38	37	36	35	34	33	32
DW7	reserved																															
DW5	reserved																															
DW3	A	H	B	X	SC	[1]	DT	Cerr [1:0]	NakCnt[3:0]			reserved			NrBytesTransferred[14:0]																	
DW1	HubAddress[6:0]						PortNumber[6:0]						SE[1:0]	Re tire	S	EP Type [1:0]	Token [1:0]	DeviceAddress[6:0]						EndPt[3:0]								
Bit	31	30	29	28	27	26	25	24	23	22	21	20	19	18	17	16	15	14	13	12	11	10	9	8	7	6	5	4	3	2	1	0
DW6	reserved																															
DW4	reserved																															
DW2	reserved			RL[3:0]			[1]	DataStartAddress[15:0]														reserved										
DW0	[2]	[1]	MaxPacketLength[10:0]										NrBytesToTransfer[14:0]														[1]	V				

[1] Reserved.

[2] EndPt[0].

Table 82. Start and complete split for bulk: bit description

Bit	Symbol	Access	Value	Description
DW7				
63 to 32	reserved	-	-	-
DW6				
31 to 0	reserved	-	-	-
DW5				
63 to 32	reserved	-	-	-
DW4				
31 to 0	reserved	-	-	-
DW3				
63	A	SW — sets HW — resets	-	Active: Write the same value as that in V.
62	H	HW — writes	-	Halt: This bit corresponds to the Halt bit of the Status field of TD.
61	B	HW — writes	-	Babble: This bit corresponds to the Babble Detected bit in the Status field of iTD, siTD, or TD. 1 — When babbling is detected, A and V are set to 0.
60	X	HW — writes	-	Transaction error: This bit corresponds to the Transaction Error bit in the Status field.
		SW — writes	-	0 — Before scheduling
59	SC	SW — writes 0 HW — updates	-	Start/complete: 0 — Start split 1 — Complete split
58	reserved	-	-	-
57	DT	HW — writes SW — writes	-	Data toggle: Set the Data Toggle bit to start for the PTD.
56 to 55	Cerr[1:0]	HW — updates SW — writes	-	Error counter: This field contains the error count for asynchronous start and complete split (SS/CS) TD. When an error has no response or bad response, Cerr[1:0] will be decremented to zero and then Valid will be set to zero. A NAK or NYET will reset Cerr[1:0]. For details, refer to Section 4.12.1.2 of <i>Enhanced Host Controller Interface Specification for Universal Serial Bus Rev. 1.0</i> . If retry has insufficient time at the beginning of a new SOF, the first PTD must be this retry. This can be accomplished if aperiodic PTD is not advanced.
54 to 51	NakCnt[3:0]	HW — writes SW — writes	-	NAK counter: The V bit is reset if NakCnt decrements to zero and RL is a non-zero value. Not applicable to isochronous split transactions.
50 to 47	reserved	-	-	-
46 to 32	NrBytes Transferred[14:0]	HW — writes	-	Number of bytes transferred: This field indicates the number of bytes sent or received for this transaction.
DW2				
31 to 29	reserved	-	-	-

Table 82. Start and complete split for bulk: bit description ...continued

Bit	Symbol	Access	Value	Description
28 to 25	RL[3:0]	SW — writes	-	Reload: If RL is set to 0h, the hardware ignores the NakCnt value. Set RL and NakCnt to the same value before a transaction. For full-speed and low-speed transactions, set this field to 0000b. Not applicable to isochronous start split and complete split.
23 to 8	DataStart Address[15:0]	SW — writes	-	Data start address: This is the start address for data that will be sent on or received from the USB bus. This is the internal memory address and not the direct CPU address. RAM address = (CPU address – 400h) / 8
7 to 0	reserved	-	-	-
DW1				
63 to 57	HubAddress[6:0]	SW — writes	-	Hub address: This indicates the hub address.
56 to 50	PortNumber[6:0]	SW — writes	-	Port number: This indicates the port number of the hub or embedded TT.
49 to 48	SE[1:0]	SW — writes	-	This depends on the endpoint type and direction. It is valid only for split transactions. Table 83 applies to start split and complete split only.
47	Retire	SW — writes	-	Retire: Set to 1 to abort this PTD.
46	S	SW — writes	-	Split: This bit indicates whether a split transaction has to be executed: 0 — High-speed transaction 1 — Split transaction
45 to 44	EPTYPE[1:0]	SW — writes	-	Endpoint type: 00 — Control 10 — Bulk
43 to 42	Token[1:0]	SW — writes	-	Token: This field indicates the PID for this transaction. 00 — OUT 01 — IN 10 — SETUP
41 to 35	DeviceAddress[6:0]	SW — writes	-	Device address: This is the USB address of the function containing the endpoint that is referred to by this buffer.
34 to 32	EndPt[3:1]	SW — writes	-	Endpoint: This is the USB address of the endpoint within the function.
DW0				
31	EndPt[0]	SW — writes	-	Endpoint: This is the USB address of the endpoint within the function.
30 to 29	reserved	-	-	-
28 to 18	MaximumPacket Length[10:0]	SW — writes	-	Maximum packet length: This field indicates the maximum number of bytes that can be sent to or received from an endpoint in a single data packet. The maximum packet size for full-speed is 64 bytes as defined in <i>Universal Serial Bus Specification Rev. 2.0</i> .

Table 82. Start and complete split for bulk: bit description ...continued

Bit	Symbol	Access	Value	Description
17 to 3	NrBytesToTransfer[14:0]	SW — writes	-	Number of bytes to transfer: This field indicates the number of bytes that can be transferred by this data structure. It is used to indicate the depth of the data field.
2 to 1	reserved	-	-	-
0	V	SW — sets HW — resets	-	Valid: 0 — This bit is deactivated when the entire PTD is executed, or when a fatal error is encountered. 1 — The software updates to one when there is payload to be sent or received. The current PTD is active.

Table 83. SE description

Bulk	Control	SE1	SE[0]	Remark
I/O	I/O	1	0	low-speed
I/O	I/O	0	0	full-speed

10.4.5 Start and complete split for isochronous

Table 84 shows the bit allocation for start and complete split for isochronous, split isochronous Transfer Descriptor (siTD).

Table 84. Start and complete split for isochronous: bit allocation

Bit	63	62	61	60	59	58	57	56	55	54	53	52	51	50	49	48	47	46	45	44	43	42	41	40	39	38	37	36	35	34	33	32
DW7	reserved																								ISO_IN_7[7:0]							
DW5	ISO_IN_2[7:0]						ISO_IN_1[7:0]						ISO_IN_0[7:0]						μSCS[7:0]													
DW3	A	H	B	X	SC	[1]	DT	reserved														NrBytesTransferred[11:0]										
DW1	HubAddress[6:0]						PortNumber[6:0]						reserved			S	EP Type [1:0]	Token [1:0]	DeviceAddress[6:0]					EndPt[3:0]								
Bit	31	30	29	28	27	26	25	24	23	22	21	20	19	18	17	16	15	14	13	12	11	10	9	8	7	6	5	4	3	2	1	0
DW6	ISO_IN_6[7:0]						ISO_IN_5[7:0]						ISO_IN_4[7:0]						ISO_IN_3[7:0]													
DW4	Status7[2:0]			Status6[2:0]			Status5[2:0]			Status4[2:0]			Status3[2:0]			Status2[2:0]			Status1[2:0]			Status0[2:0]			μSA[7:0]							
DW2	reserved						DataStartAddress[15:0]															μFrame[7:0] (full-speed)										
DW0	[2]	[1]	TT_MPS_Len[10:0]						NrBytesToTransfer[14:0] (1 kB for full-speed)														[1]	V								

[1] Reserved.

[2] EndPt[0].

Table 85. Start and complete split for isochronous: bit description

Bit	Symbol	Access	Value	Description
DW7				
63 to 40	reserved	-	-	-
39 to 32	ISO_IN_7[7:0]	HW — writes	-	Isochronous IN 7: Bytes received during μ SOF7, if μ SA[7] is set to 1 and frame number is correct.
DW6				
31 to 24	ISO_IN_6[7:0]	HW — writes	-	Isochronous IN 6: Bytes received during μ SOF6, if μ SA[6] is set to 1 and frame number is correct.
23 to 16	ISO_IN_5[7:0]	HW — writes	-	Isochronous IN 5: Bytes received during μ SOF5, if μ SA[5] is set to 1 and frame number is correct.
15 to 8	ISO_IN_4[7:0]	HW — writes	-	Isochronous IN 4: Bytes received during μ SOF4, if μ SA[4] is set to 1 and frame number is correct.
7 to 0	ISO_IN_3[7:0]	HW — writes	-	Isochronous IN 3: Bytes received during μ SOF3, if μ SA[3] is set to 1 and frame number is correct.
DW5				
63 to 56	ISO_IN_2[7:0]	HW — writes	-	Isochronous IN 2: Bytes received during μ SOF2, if μ SA[2] is set to 1 and frame number is correct.
55 to 48	ISO_IN_1[7:0]	HW — writes	-	Isochronous IN 1: Bytes received during μ SOF1, if μ SA[1] is set to 1 and frame number is correct.
47 to 40	ISO_IN_0[7:0]	HW — writes	-	Isochronous IN 0: Bytes received during μ SOF0 if μ SA[0] is set to 1 and frame number is correct.
39 to 32	μ SCS[7:0]	SW — writes (0 \rightarrow 1) HW — writes (1 \rightarrow 0) After processing	-	μSCS: All bits can be set to one for every transfer. It specifies which μ SOF the complete split needs to be sent. Valid only for IN. Start split and complete split active bits, μ SA = 0000 0001 and μ SCS = 0000 0100, will cause SS to execute in μ Frame0 and CS in μ Frame2.
DW4				
31 to 29	Status7[2:0]	HW — writes	-	Status 7: Isochronous IN or OUT status of μ SOF7
28 to 26	Status6[2:0]	HW — writes	-	Status 6: Isochronous IN or OUT status of μ SOF6
25 to 23	Status5[2:0]	HW — writes	-	Status 5: Isochronous IN or OUT status of μ SOF5
22 to 20	Status4[2:0]	HW — writes	-	Status 4: Isochronous IN or OUT status of μ SOF4
19 to 17	Status3[2:0]	HW — writes	-	Status 3: Isochronous IN or OUT status of μ SOF3
16 to 14	Status2[2:0]	HW — writes	-	Status 2: Isochronous IN or OUT status of μ SOF2
13 to 11	Status1[2:0]	HW — writes	-	Status 1: Isochronous IN or OUT status of μ SOF1
10 to 8	Status0[2:0]	HW — writes	-	Status 0: Isochronous IN or OUT status of μ SOF0 Bit 0 — Transaction error (IN and OUT) Bit 1 — Babble (IN token only) Bit 2 — Underrun (OUT token only)
7 to 0	μ SA[7:0]	SW — writes (0 \rightarrow 1) HW — writes (1 \rightarrow 0) After processing	-	μSA: Specifies which μ SOF the start split needs to be placed. For OUT token: When the frame number of bits DW2[7:3] matches the frame number of the USB bus, these bits are checked for one before they are sent for the μ SOF. For IN token: Only μ SOF0, μ SOF1, μ SOF2, or μ SOF3 can be set to 1. Nothing can be set for μ SOF4 and above.

Table 85. Start and complete split for isochronous: bit description ...continued

Bit	Symbol	Access	Value	Description
DW3				
63	A	SW — sets HW — resets	-	Active: Write the same value as that in V.
62	H	HW — writes	-	Halt: The Halt bit is set when any microframe transfer status has a stalled or halted condition.
61	B	HW — writes	-	Babble: This bit corresponds to bit 1 of Status0 to Status7 for every microframe transfer status.
60	X	HW — writes	-	Transaction error: This bit corresponds to bit 0 of Status0 to Status7 for every microframe transfer status.
59	SC	SW — writes 0 HW — updates	-	Start/complete: 0 — Start split 1 — Complete split
58	reserved	-	-	-
57	DT	HW — writes SW — writes	-	Data toggle: Set the Data Toggle bit to start for the PTD.
56 to 44	reserved	-	-	-
43 to 32	NrBytes Transferred [11:0]	HW — writes	-	Number of bytes transferred: This field indicates the number of bytes sent or received for this transaction.
DW2				
31 to 24	reserved	-	-	-
23 to 8	DataStart Address[15:0]	SW — writes	-	Data start address: This is the start address for data that will be sent on or received from the USB bus. This is the internal memory address and not the CPU address.
7 to 0	μFrame[7:0]	SW — writes	-	μFrame: Bits 7 to 3 determine which frame to execute.
DW1				
63 to 57	HubAddress [6:0]	SW — writes	-	Hub address: This indicates the hub address.
56 to 50	PortNumber [6:0]	SW — writes	-	Port number: This indicates the port number of the hub or embedded TT.
49 to 47	reserved	-	-	-
46	S	SW — writes	-	Split: This bit indicates whether a split transaction must be executed: 0 — High-speed transaction 1 — Split transaction
45 to 44	EPTYPE[1:0]	SW — writes	-	Transaction type: 01 — Isochronous
43 to 42	Token[1:0]	SW — writes	-	Token: Token PID for this transaction: 00 — OUT 01 — IN
41 to 35	Device Address[6:0]	SW — writes	-	Device address: This is the USB address of the function containing the endpoint that is referred to by this buffer.
34 to 32	EndPt[3:1]	SW — writes	-	Endpoint: This is the USB address of the endpoint within the function.

Table 85. Start and complete split for isochronous: bit description ...continued

Bit	Symbol	Access	Value	Description
DW0				
31	EndPt[0]	SW — writes	-	Endpoint: This is the USB address of the endpoint within the function.
30 to 29	reserved	-	-	-
28 to 18	TT_MPS_Len [10:0]	SW — writes	-	Transaction translator maximum packet size length: This field indicates the maximum number of bytes that can be sent per start split depending on the number of total bytes needed. If the total bytes to be sent for the entire millisecond is greater than 188 bytes, this field must be set to 188 bytes for an OUT token and 192 bytes for an IN token. Otherwise, this field must be equal to the total bytes sent.
17 to 3	NrBytesTo Transfer[14:0]	SW — writes	-	Number of bytes to transfer: This field indicates the number of bytes that can be transferred by this data structure. It is used to indicate the depth of the data field. This field is restricted to 1023 bytes because in siTD the maximum allowable payload for a full-speed device is 1023 bytes. This field indirectly becomes the maximum packet size of the downstream device.
2 to 1	reserved	-	-	-
0	V	SW — sets HW — resets	-	Valid: 0 — This bit is deactivated when the entire PTD is executed, or when a fatal error is encountered. 1 — The software updates to one when there is payload to be sent or received. The current PTD is active.

10.4.6 Start and complete split for interrupt

Table 86 shows the bit allocation of start and complete split for interrupt.

Table 86. Start and complete split for interrupt: bit allocation

Bit	63	62	61	60	59	58	57	56	55	54	53	52	51	50	49	48	47	46	45	44	43	42	41	40	39	38	37	36	35	34	33	32
DW7	reserved																								INT_IN_7[7:0]							
DW5	INT_IN_2[7:0]						INT_IN_1[7:0]						INT_IN_0[7:0]						μSCS[7:0]													
DW3	A	H	B	X	SC	[1]	DT	Cerr [1:0]	reserved											NrBytesTransferred[11:0] (4 kB for full-speed and low-speed)												
DW1	HubAddress[6:0]						PortNumber[6:0]						SE[1:0]	-	S	EP Type [1:0]	Token [1:0]	DeviceAddress[6:0]				EndPt[3:0]										
Bit	31	30	29	28	27	26	25	24	23	22	21	20	19	18	17	16	15	14	13	12	11	10	9	8	7	6	5	4	3	2	1	0
DW6	INT_IN_6[7:0]						INT_IN_5[7:0]						INT_IN_4[7:0]						INT_IN_3[7:0]													
DW4	Status7[2:0]			Status6[2:0]			Status5[2:0]			Status4[2:0]			Status3[2:0]			Status2[2:0]			Status1[2:0]			Status0[2:0]			μSA[7:0]							
DW2	reserved						DataStartAddress[15:0]											μFrame[7:0] (full-speed and low-speed)														
DW0	[2]	[1]	MaxPacketLength[10:0]						NrBytesToTransfer[14:0] (4 kB for full-speed and low-speed)											[1]	V											

[1] Reserved.

[2] EndPt[0].

Table 87. Start and complete split for interrupt: bit description

Bit	Symbol	Access	Value	Description
DW7				
63 to 40	reserved	-	-	-
39 to 32	INT_IN_7[7:0]	HW — writes	-	Interrupt IN 7: Bytes received during μ SOF7, if μ SA[7] is set to 1 and frame number is correct. The new value continuously overwrites the old value.
DW6				
31 to 24	INT_IN_6[7:0]	HW — writes	-	Interrupt IN 6: Bytes received during μ SOF6, if μ SA[6] is set to 1 and frame number is correct. The new value continuously overwrites the old value.
23 to 16	INT_IN_5[7:0]	HW — writes	-	Interrupt IN 5: Bytes received during μ SOF5, if μ SA[5] is set to 1 and frame number is correct. The new value continuously overwrites the old value.
15 to 8	INT_IN_4[7:0]	HW — writes	-	Interrupt IN 4: Bytes received during μ SOF4, if μ SA[4] is set to 1 and frame number is correct. The new value continuously overwrites the old value.
7 to 0	INT_IN_3[7:0]	HW — writes	-	Interrupt IN 3: Bytes received during μ SOF3, if μ SA[3] is set to 1 and frame number is correct. The new value continuously overwrites the old value.
DW5				
63 to 56	INT_IN_2[7:0]	HW — writes	-	Interrupt IN 2: Bytes received during μ SOF2, if μ SA[2] is set to 1 and frame number is correct. The new value continuously overwrites the old value.
55 to 48	INT_IN_1[7:0]	HW — writes	-	Interrupt IN 1: Bytes received during μ SOF1, if μ SA[1] is set to 1 and frame number is correct. The new value continuously overwrites the old value.
47 to 40	INT_IN_0[7:0]	HW — writes	-	Interrupt IN 0: Bytes received during μ SOF0, if μ SA[0] is set to 1 and frame number is correct. The new value continuously overwrites the old value.
39 to 32	μ SCS[7:0]	SW — writes (0 \rightarrow 1) HW — writes (1 \rightarrow 0) After processing	-	μSCS: All bits can be set to one for every transfer. It specifies which μ SOF the complete split needs to be sent. Valid only for IN. Start split and complete split active bits, μ SA = 0000 0001 and μ SCS = 0000 0100, will cause SS to execute in μ Frame0 and CS in μ Frame2.
DW4				
31 to 29	Status7[2:0]	HW — writes	-	Status 7: Interrupt IN or OUT status of μ SOF7
28 to 26	Status6[2:0]	HW — writes	-	Status 6: Interrupt IN or OUT status of μ SOF6
25 to 23	Status5[2:0]	HW — writes	-	Status 5: Interrupt IN or OUT status of μ SOF5
22 to 20	Status4[2:0]	HW — writes	-	Status 4: Interrupt IN or OUT status of μ SOF4
19 to 17	Status3[2:0]	HW — writes	-	Status 3: Interrupt IN or OUT status of μ SOF3
16 to 14	Status2[2:0]	HW — writes	-	Status 2: Interrupt IN or OUT status of μ SOF2
13 to 11	Status1[2:0]	HW — writes	-	Status 1: Interrupt IN or OUT status of μ SOF1
10 to 8	Status0[2:0]	HW — writes	-	Status 0: Interrupt IN or OUT status of μ SOF0 Bit 0 — Transaction error (IN and OUT) Bit 1 — Babble (IN token only) Bit 2 — Underrun (OUT token only)

Table 87. Start and complete split for interrupt: bit description ...continued

Bit	Symbol	Access	Value	Description
7 to 0	$\mu\text{SA}[7:0]$	SW — writes (0 → 1) HW — writes (1 → 0) After processing	-	μSA : Specifies which μSOF the start split needs to be placed. For OUT token : When the frame number of bits DW2[7:3] matches the frame number of the USB bus, these bits are checked for one before they are sent for μSOF . For IN token : Only $\mu\text{SOF}0$, $\mu\text{SOF}1$, $\mu\text{SOF}2$, or $\mu\text{SOF}3$ can be set to 1. Nothing can be set for $\mu\text{SOF}4$ and above.
DW3				
63	A	SW — sets HW — resets	-	Active : Write the same value as that in V.
62	H	HW — writes	-	Halt : The Halt bit is set when any microframe transfer status has a stalled or halted condition.
61	B	HW — writes	-	Babble : This bit corresponds to bit 1 of Status0 to Status7 for every microframe transfer status.
60	X	HW — writes	-	Transaction error : This bit corresponds to bit 0 of Status0 to Status7 for every microframe transfer status.
59	SC	SW — writes 0 HW — updates	-	Start/complete : 0 — Start split 1 — Complete split
58	reserved	-	-	-
57	DT	HW — writes SW — writes	-	Data toggle : For an interrupt transfer, set correct bit to start the PTD.
56 to 55	Cerr[1:0]	HW — writes SW — writes	-	Error counter : This field corresponds to the Cerr[1:0] field in TD. 00 — The transaction will not retry. 11 — The transaction will retry three times. The hardware will decrement these values.
54 to 44	reserved	-	-	-
43 to 32	NrBytes Transferred[11:0]	HW — writes	-	Number of bytes transferred : This field indicates the number of bytes sent or received for this transaction.
DW2				
31 to 24	reserved	-	-	-
23 to 8	DataStart Address[15:0]	SW — writes	-	Data start address : This is the start address for data that will be sent on or received from the USB bus. This is the internal memory address and not the CPU address.
7 to 0	$\mu\text{Frame}[7:0]$	SW — writes	-	μFrame : Bits 7 to 3 is the polling rate in milliseconds. Polling rate is defined as $2^{(b-1)} \mu\text{SOF}$; where $b = 4$ to 16. Executed every millisecond when b is 4. See Table 88 .
DW1				
63 to 57	HubAddress[6:0]	SW — writes	-	Hub address : This indicates the hub address.
56 to 50	PortNumber[6:0]	SW — writes	-	Port number : This indicates the port number of the hub or embedded TT.
49 to 48	SE[1:0]	SW — writes	-	This depends on the endpoint type and direction. It is valid only for split transactions. Table 89 applies to start split and complete split only.
47	reserved	-	-	-

Table 87. Start and complete split for interrupt: bit description ...continued

Bit	Symbol	Access	Value	Description
46	S	SW — writes	-	Split: This bit indicates whether a split transaction has to be executed: 0 — High-speed transaction 1 — Split transaction
45 to 44	EPTyep[1:0]	SW — writes	-	Transaction type: 11 — Interrupt
43 to 42	Token[1:0]	SW — writes	-	Token: Token PID for this transaction: 00 — OUT 01 — IN
41 to 35	DeviceAddress [6:0]	SW — writes	-	Device address: This is the USB address of the function containing the endpoint that is referred to by this buffer.
34 to 32	EndPt[3:1]	SW — writes	-	Endpoint: This is the USB address of the endpoint within the function.
DW0				
31	EndPt[0]	SW — writes	-	Endpoint: This is the USB address of the endpoint within the function.
30 to 29	reserved	-	-	-
28 to 18	MaxPacket Length[10:0]	SW — writes	-	Maximum packet length: This field indicates the maximum number of bytes that can be sent to or received from an endpoint in a single data packet. The maximum packet size for the full-speed and low-speed devices is 64 bytes as defined in <i>Universal Serial Bus Specification Rev. 2.0</i> .
17 to 3	NrBytesTo Transfer[14:0]	SW — writes	-	Number of bytes to transfer: This field indicates the number of bytes that can be transferred by this data structure. It is used to indicate the depth of the data field. The maximum total number of bytes for this transaction is 4 kB.
2 to 1	reserved	-	-	-
0	V	SW — sets HW — resets	-	Valid: 0 — This bit is deactivated when the entire PTD is executed, or when a fatal error is encountered. 1 — The software updates to one when there is payload to be sent or received. The current PTD is active.

Table 88. Microframe description

b	Rate	μFrame[7:3]
5	2 ms	0 0001
6	4 ms	0 0010 or 0 0011
7	8 ms	0 0100 or 0 0111
8	16 ms	0 1000 or 0 1111
9	32 ms	1 0000 or 1 1111

Table 89. SE description

Interrupt	SE1	SE0	Remark
I/O	1	0	low-speed
I/O	0	0	full-speed

11. Peripheral controller-specific registers

Table 90. Peripheral controller-specific register overview

Address	Register	Reset value	Reference
Initialization registers			
00h	Address	00h	Section 11.2.1 on page 85
0Ch	Mode	0000h	Section 11.2.2 on page 85
10h	Interrupt Configuration	FCh	Section 11.2.3 on page 86
14h	DcInterruptEnable	0000 0000h	Section 11.2.4 on page 87
Data flow registers			
2Ch	Endpoint Index	20h	Section 11.3.1 on page 89
28h	Control Function	00h	Section 11.3.2 on page 90
20h	Data Port	0000h	Section 11.3.3 on page 91
1Ch	Buffer Length	0000h	Section 11.3.4 on page 92
1Eh	DcBufferStatus	00h	Section 11.3.5 on page 93
04h	Endpoint MaxPacketSize	0000h	Section 11.3.6 on page 93
08h	Endpoint Type	0000h	Section 11.3.7 on page 94
DMA registers			
30h	DMA Command	FFh	Section 11.4.1 on page 96
34h	DMA Transfer Counter	0000 0000h	Section 11.4.2 on page 97
38h	DcDMAConfiguration	0001h	Section 11.4.3 on page 98
3Ch	DMA Hardware	04h	Section 11.4.4 on page 99
50h	DMA Interrupt Reason	0000h	Section 11.4.5 on page 99
54h	DMA Interrupt Enable	0000h	Section 11.4.6 on page 100
58h	DMA Endpoint	00h	Section 11.4.7 on page 101
64h	DMA Burst Counter	0004h	Section 11.4.8 on page 102
General registers			
18h	DcInterrupt	0000 0000h	Section 11.5.1 on page 102
70h	Chip ID	0017 6320h	Section 11.5.2 on page 104
74h	Frame Number	0000h	Section 11.5.3 on page 104
78h	Scratch	0000h	Section 11.5.4 on page 105
7Ch	Unlock Device	-	Section 11.5.5 on page 105
80h	Interrupt Pulse Width	1Eh	Section 11.5.6 on page 106
84h	Test Mode	00h	Section 11.5.7 on page 106

11.1 Register access

Register access depends on the bus width used. The ISP1763A uses an 8-bit or 16-bit bus access. For single-byte registers, the upper byte (MSByte) must be ignored.

Endpoint-specific registers are indexed using the Endpoint Index register. The target endpoint must be selected before accessing the following registers:

- Control Function
- Data Port

- Buffer Length
- DcBufferStatus
- Endpoint MaxPacketSize
- Endpoint Type

Remark: All reserved bits are not implemented. The bus and bus reset values are not defined. Therefore, writing to these reserved bits will have no effect.

11.2 Initialization registers

11.2.1 Address register

This register sets the USB assigned address and enables the USB peripheral. [Table 91](#) shows the bit allocation of the register.

The DEVADDR[6:0] bits will be cleared whenever a bus reset, a power-on reset, or a soft reset occurs. The DEVEN bit will be cleared whenever a power-on reset or a soft reset occurs, and will remain unchanged on a bus reset.

In response to standard USB request SET_ADDRESS, the firmware must write the (enabled) peripheral address to the Address register, followed by sending an empty packet to the host. The new peripheral address is activated when the peripheral receives acknowledgment from the host for the empty packet token.

Table 91. ADDR - Address register (address 00h) bit allocation

Bit	7	6	5	4	3	2	1	0
Symbol	DEVEN	DEVADDR[6:0]						
Reset	0	0	0	0	0	0	0	0
Bus reset	unchanged	0	0	0	0	0	0	0
Access	R/W	R/W	R/W	R/W	R/W	R/W	R/W	R/W

Table 92. ADDR - Address register (address 00h) bit description

Bit	Symbol	Description
7	DEVEN	Device enable: Logic 1 enables the device. The device will not respond to the host, unless this bit is set.
6 to 0	DEVADDR[6:0]	Device address: This field specifies the USB device peripheral.

11.2.2 Mode register

This register consists of 2 bytes (bit allocation: see [Table 93](#)).

The Mode register controls resume, suspend and wake-up behavior, interrupt activity, soft reset, and clock signals.

Table 93. MODE - Mode register (address 0Ch) bit allocation

Bit	15	14	13	12	11	10	9	8
Symbol	reserved ^[1]						DMACKLON	VBUSSTAT
Reset	0	0	0	0	0	0	0	0
Bus reset	0	0	0	0	0	0	0	0
Access	R/W	R/W	R/W	R/W	R/W	R/W	R/W	R

Bit	7	6	5	4	3	2	1	0
Symbol	CLKAON	SNDRSU	GOSUSP	SFRESET	GLINTENA	WKUPCS	reserved ^[1]	
Reset	0	0	0	0	0	0	0	0
Bus reset	0	0	0	0	unchanged	0	0	unchanged
Access	R/W	R/W	R/W	R/W	R/W	R/W	R/W	R/W

[1] The reserved bits should always be written with the reset value.

Table 94. MODE - Mode register (address 0Ch) bit description

Bit	Symbol	Description
15 to 10	-	reserved
9	DMACLKON	DMA clock on: 1 — Supply clock to the DMA circuit. 0 — Power saving mode. The DMA circuit will stop completely to save power.
8	VBUSSTAT	V_{BUS} status: This bit reflects the V _{BUS} pin status when the OTG_DISABLE bit is logic 1.
7	CLKAON	Clock always on: 1 — Enable the Clock-Always-On feature. 0 — Disable the Clock-Always-On feature. When the Clock-Always-On feature is disabled, a GOSUSP event can stop the clock. The clock is stopped after a delay of approximately 2 ms. Therefore, the peripheral controller will consume less power. If the Clock-Always-On feature is enabled, clocks are always running and the GOSUSP event is unable to stop the clock while the peripheral controller enters the suspend state.
6	SNDRSU	Send resume: Writing logic 1, followed by logic 0 will generate an upstream resume signal of 10 ms duration, after a 5 ms delay.
5	GOSUSP	Go suspend: Writing logic 1, followed by logic 0 will activate suspend mode.
4	SFRESET	Soft reset: Writing logic 1, followed by logic 0 will enable a software-initiated reset to the ISP1763A. A soft reset is similar to a hardware-initiated reset using the RESET_N pin.
3	GLINTENA	Global interrupt enable: Logic 1 enables all interrupts. Individual interrupts can be masked by clearing the corresponding bits in the DcInterruptEnable register. When this bit is not set, an unmasked interrupt will not generate an interrupt trigger on the interrupt pin. If the global interrupt, however, is enabled while there is any pending unmasked interrupt, an interrupt signal will immediately be generated on the interrupt pin. If the interrupt is set to pulse mode, the interrupt events that were generated before the global interrupt is enabled may be dropped.
2	WKUPCS	Wake up on chip select: Logic 1 enables wake-up through a valid register read on the ISP1763A. A read will invoke the chip clock to restart. A write to the register before the clock is stable may cause malfunctioning.
1 to 0	-	reserved

11.2.3 Interrupt Configuration register

This 1 byte register determines the behavior and polarity of the INT output. The bit allocation is shown in [Table 95](#). When the USB SIE receives or generates an ACK, NAK, or NYET, it will generate interrupts depending on three Debug mode fields.

CDBGMOD[1:0] — Interrupts for control endpoint 0

DDBGMODIN[1:0] — Interrupts for data IN endpoints 1 to 7

DDBGMODOUT[1:0] — Interrupts for data OUT endpoints 1 to 7

The Debug mode settings for CDBGMOD, DDBGMODIN, and DDBGMODOUT allow you to individually configure when the ISP1763A sends an interrupt to the external microprocessor. [Table 97](#) lists available combinations.

Bit INTPOL controls the signal polarity of the INT output: active HIGH or LOW, rising or falling edge. For level-triggering, bit INTLVL must be made logic 0. By setting INTLVL to logic 1, an interrupt will generate a pulse of 60 ns (edge-triggering).

Table 95. INTR_CONF - Interrupt Configuration register (address 10h) bit allocation

Bit	7	6	5	4	3	2	1	0
Symbol	CDBGMOD[1:0]		DDBGMODIN[1:0]		DDBGMODOUT[1:0]		INTLVL	INTPOL
Reset	1	1	1	1	1	1	0	0
Bus reset	1	1	1	1	1	1	unchanged	unchanged
Access	R/W	R/W	R/W	R/W	R/W	R/W	R/W	R/W

Table 96. INTR_CONF - Interrupt Configuration register (address 10h) bit description

Bit	Symbol	Description
7 to 6	CDBGMOD[1:0]	Control 0 debug mode: For values, see Table 97 .
5 to 4	DDBGMODIN[1:0]	Data debug mode IN: For values, see Table 97 .
3 to 2	DDBGMODOUT[1:0]	Data debug mode OUT: For values, see Table 97 .
1	INTLVL	Interrupt level: Selects signaling mode on output INT: 0 = level; 1 = pulsed. In pulsed mode, an interrupt produces a 60 ns pulse. Bus reset value: unchanged. Remark: Value written to this bit must be the same as the value written to bit INTR_LEVEL in the HW Mode Control register (address B6h).
0	INTPOL	Interrupt polarity: Selects the signal polarity on output INT; 0 = active LOW; 1 = active HIGH. Bus reset value: unchanged. Remark: Value written to this bit must be the same as the value written to bit INTR_POL in the HW Mode Control register (address B6h).

Table 97. Debug mode settings

Value	CDBGMOD	DDBGMODIN	DDBGMODOUT
00h	interrupt on all ACK and NAK	interrupt on all ACK and NAK	interrupt on all ACK, NYET, and NAK
01h	interrupt on all ACK	interrupt on ACK	interrupt on ACK and NYET
1Xh	interrupt on all ACK and first NAK ^[1]	interrupt on all ACK and first NAK ^[1]	interrupt on all ACK, NYET, and first NAK ^[1]

[1] First NAK: The first NAK on an IN or OUT token after a previous ACK response.

11.2.4 DcInterruptEnable register

This register enables or disables individual interrupt sources. The interrupt for each endpoint can individually be controlled through the associated IEPnRX or IEPnTX bits, here n represents the endpoint number. All interrupts can globally be disabled through bit GLINTENA in the Mode register (see [Table 93](#)).

An interrupt is generated when the USB SIE receives or generates an ACK or NAK on the USB bus. The interrupt generation depends on Debug mode settings of bit fields CDBGMOD[1:0], DDBGMODIN[1:0], and DDBGMODOUT[1:0].

All data IN transactions use Transmit buffers (TX) that are handled by DDBGMODIN bits. All data OUT transactions go through Receive buffers (RX) that are handled by DDBGMODOUT bits. Transactions on control endpoint 0 (IN, OUT, and SETUP) are handled by CDBGMOD bits.

Interrupts caused by events on the USB bus (SOF, suspend, resume, bus reset, set up, and high-speed status) can also be individually controlled. A bus reset disables all enabled interrupts, except bit IEBRST (bus reset) that remains unchanged.

The DcInterruptEnable register consists of 4 bytes. The bit allocation is given in [Table 98](#).

Table 98. DcInterruptEnable - Device Controller Interrupt Enable register (address 14h) bit allocation

Bit	31	30	29	28	27	26	25	24
Symbol	reserved ^[1]						IEP7TX	IEP7RX
Reset	0	0	0	0	0	0	0	0
Bus reset	0	0	0	0	0	0	0	0
Access	R/W	R/W	R/W	R/W	R/W	R/W	R/W	R/W
Bit	23	22	21	20	19	18	17	16
Symbol	IEP6TX	IEP6RX	IEP5TX	IEP5RX	IEP4TX	IEP4RX	IEP3TX	IEP3RX
Reset	0	0	0	0	0	0	0	0
Bus reset	0	0	0	0	0	0	0	0
Access	R/W	R/W	R/W	R/W	R/W	R/W	R/W	R/W
Bit	15	14	13	12	11	10	9	8
Symbol	IEP2TX	IEP2RX	IEP1TX	IEP1RX	IEP0TX	IEP0RX	reserved ^[1]	IEP0SETUP
Reset	0	0	0	0	0	0	-	0
Bus reset	0	0	0	0	0	0	-	0
Access	R/W	R/W	R/W	R/W	R/W	R/W	R/W	R/W
Bit	7	6	5	4	3	2	1	0
Symbol	IEVBUS	IEDMA	IEHS_STA	IERESM	IESUSP	IEPSOF	IESOF	IEBRST
Reset	0	0	0	0	0	0	0	0
Bus reset	0	0	0	0	0	0	0	unchanged
Access	R/W	R/W	R/W	R/W	R/W	R/W	R/W	R/W

[1] The reserved bits should always be written with the reset value.

Table 99. DcInterruptEnable - Device Controller Interrupt Enable register (address 14h) bit description

Bit	Symbol	Description
31 to 26	-	reserved
25	IEP7TX	Interrupt enable endpoint 7 transmit: Logic 1 enables interrupt from the indicated endpoint.
24	IEP7RX	Interrupt enable endpoint 7 receive: Logic 1 enables interrupt from the indicated endpoint.
23	IEP6TX	Interrupt enable endpoint 6 transmit: Logic 1 enables interrupt from the indicated endpoint.
22	IEP6RX	Interrupt enable endpoint 6 receive: Logic 1 enables interrupt from the indicated endpoint.
21	IEP5TX	Interrupt enable endpoint 5 transmit: Logic 1 enables interrupt from the indicated endpoint.
20	IEP5RX	Interrupt enable endpoint 5 receive: Logic 1 enables interrupt from the indicated endpoint.
19	IEP4TX	Interrupt enable endpoint 4 transmit: Logic 1 enables interrupt from the indicated endpoint.
18	IEP4RX	Interrupt enable endpoint 4 receive: Logic 1 enables interrupt from the indicated endpoint.

Table 99. DcInterruptEnable - Device Controller Interrupt Enable register (address 14h) bit description ...continued

Bit	Symbol	Description
17	IEP3TX	Interrupt enable endpoint 3 transmit: Logic 1 enables interrupt from the indicated endpoint.
16	IEP3RX	Interrupt enable endpoint 3 receive: Logic 1 enables interrupt from the indicated endpoint.
15	IEP2TX	Interrupt enable endpoint 2 transmit: Logic 1 enables interrupt from the indicated endpoint.
14	IEP2RX	Interrupt enable endpoint 2 receive: Logic 1 enables interrupt from the indicated endpoint.
13	IEP1TX	Interrupt enable endpoint 1 transmit: Logic 1 enables interrupt from the indicated endpoint.
12	IEP1RX	Interrupt enable endpoint 1 receive: Logic 1 enables interrupt from the indicated endpoint.
11	IEP0TX	Interrupt enable endpoint 0 transmit: Logic 1 enables interrupt from the control IN endpoint 0.
10	IEP0RX	Interrupt enable endpoint 0 receive: Logic 1 enables interrupt from the control OUT endpoint 0.
9	-	reserved
8	IEP0SETUP	Interrupt enable endpoint 0 set-up: Logic 1 enables interrupt for the set-up data received on endpoint 0.
7	IEVBUS	Interrupt enable V_{BUS}: Logic 1 enables interrupt when there is a polarity change on V _{BUS} .
6	IEDMA	Interrupt enable DMA: Logic 1 enables interrupt on detecting a DMA status change.
5	IEHS_STA	Interrupt enable high-speed status: Logic 1 enables interrupt on detecting a high-speed status change.
4	IERESM	Interrupt enable resume: Logic 1 enables interrupt on detecting a resume state.
3	IESUSP	Interrupt enable suspend: Logic 1 enables interrupt on detecting a suspend state.
2	IEPSOF	Interrupt enable pseudo SOF: Logic 1 enables interrupt on detecting a pseudo SOF.
1	IESOF	Interrupt enable SOF: Logic 1 enables interrupt on detecting an SOF.
0	IEBRST	Interrupt enable bus reset: Logic 1 enables interrupt on detecting a bus reset.

11.3 Data flow registers

11.3.1 Endpoint Index register

The Endpoint Index register selects a target endpoint for register access by the microcontroller. The register consists of 1 byte, and the bit allocation is shown in [Table 100](#).

The following registers are indexed:

- Control Function
- Data Port
- Buffer Length
- DcBufferStatus
- Endpoint MaxPacketSize
- Endpoint Type

For example, to access the OUT data buffer of endpoint 1 using the Data Port register, the Endpoint Index register must be written first with 02h.

Remark: The Endpoint Index register and the DMA Endpoint register must not point to the same endpoint, irrespective of IN and OUT.

Remark: After writing to the Endpoint Index register, wait for 400 ns before accessing any register.

Table 100. ENDP_INDEX - Endpoint Index register (address 2Ch) bit allocation

Bit	7	6	5	4	3	2	1	0
Symbol	reserved ^[1]		EPOSETUP	reserved ^[1]	ENDPIDX[2:0]			DIR
Reset	0	0	1	0	0	0	0	0
Bus reset	0	0	1	0	0	0	0	0
Access	R/W	R/W	R/W	R/W	R/W	R/W	R/W	R/W

[1] The reserved bits should always be written with the reset value.

Table 101. ENDP_INDEX - Endpoint Index register (address 2Ch) bit description

Bit	Symbol	Description
7 to 6	-	reserved
5	EPOSETUP	Endpoint 0 set up: Selects the set-up token buffer for endpoint 0. Must be logic 0 for access to endpoints other than the set-up token buffer. 0 — Any buffer other than the set-up token buffer. This means control IN endpoint, control OUT endpoint, data IN endpoint, and data OUT endpoint. 1 — Set-up token buffer
4	-	reserved
3 to 1	ENDPIDX[2:0]	Endpoint index: Selects the target endpoint buffer.
0	DIR	Direction: Sets the target endpoint as IN or OUT. 0 — Target endpoint refers to OUT (RX) FIFO. 1 — Target endpoint refers to IN (TX) FIFO.

Table 102. Addressing of endpoint buffers

Buffer name	EPOSETUP	ENDPIDX	DIR
SETUP	1	00h	0
Control OUT	0	00h	0
Control IN	0	00h	1
Data OUT	0	0Xh	0
Data IN	0	0Xh	1

11.3.2 Control Function register

The Control Function register performs the buffer management on endpoints. It consists of 1 byte, and the bit allocation is given in [Table 103](#). The register bits can stall, clear, or validate any enabled data endpoint. Before accessing this register, the Endpoint Index register must be written first to specify the target endpoint.

Table 103. CTRL_FUNC- Control Function register (address 28h) bit allocation

Bit	7	6	5	4	3	2	1	0
Symbol	reserved ^[1]			CLBUF	VENDP	DSEN	STATUS	STALL
Reset	0	0	0	0	0	0	0	0
Bus reset	0	0	0	0	0	0	0	0
Access	R/W	R/W	R/W	R/W	R/W	R/W	R/W	R/W

[1] The reserved bits should always be written with the reset value.

Table 104. CTRL_FUNC- Control Function register (address 28h) bit description

Bit	Symbol	Description
7 to 5	-	reserved
4	CLBUF	<p>Clear buffer: Logic 1 clears the RX buffer of the indexed endpoint. The RX buffer is automatically cleared once the endpoint is completely read. This bit is set only when it is necessary to forcefully clear the buffer.</p> <p>Remark: If using a double buffer, to clear both the buffers, issue the CLBUF command two times, that is, set and clear this bit two times.</p>
3	VENDP	<p>Validate endpoint: Logic 1 validates data in the TX FIFO of an IN endpoint for sending on the next IN token. In general, the endpoint is automatically validated when its FIFO byte count has reached endpoint MaxPacketSize. This bit is set only when it is necessary to validate the endpoint with the FIFO byte count that is below the endpoint MaxPacketSize.</p>
2	DSEN	<p>Data stage enable: This bit controls the response of the ISP1763A to a control transfer. After the completion of the set-up stage, the firmware must determine whether a data stage is required. For control OUT, the firmware will set this bit and the ISP1763A goes into the data stage. Otherwise, the ISP1763A will NAK the data stage transfer. For control IN, the firmware will set this bit before writing data to the TX FIFO and validate the endpoint. If no data stage is required, the firmware can immediately set the STATUS bit after the set-up stage.</p>
1	STATUS	<p>Status acknowledge: Only applicable for control IN and OUT.</p> <p>This bit controls the generation of ACK or NAK during the status stage of a SETUP transfer. It is automatically cleared when the status stage is completed and a SETUP token is received. No interrupt signal will be generated.</p> <p>0 — Sends NAK</p> <p>1 — Sends an empty packet following the IN token (peripheral-to-host) or ACK following the OUT token (host-to-peripheral)</p> <p>Remark: The STATUS bit is cleared to zero once the zero-length packet is acknowledged by the device or the PC host.</p> <p>Remark: Data transfers preceding the status stage must first be fully completed before the STATUS bit can be set.</p>
0	STALL	<p>Stall endpoint: Logic 1 stalls the indexed endpoint. This bit is not applicable for isochronous transfers.</p> <p>Remark: Stalling a data endpoint will confuse the Data Toggle bit about the stalled endpoint because the internal logic picks up from where it is stalled. Therefore, the Data Toggle bit must be reset by disabling and re-enabling the corresponding endpoint (by setting bit ENABLE to logic 0, followed by logic 1 in the Endpoint Type register) to reset the PID.</p>

11.3.3 Data Port register

This 2-byte register provides direct access for a microcontroller to the FIFO of the indexed endpoint. The bit allocation is shown in [Table 105](#).

Peripheral to host (IN endpoint): After each write, an internal counter is automatically incremented, by two in 16-bit mode and one in 8-bit mode, to the next location in the TX FIFO. When all bytes have been written (FIFO byte count = endpoint MaxPacketSize), the buffer is automatically validated. The data packet will then be sent on the next IN token. Whenever required, the Control Function register (bit VENDP) can validate the endpoint whose byte count is less than MaxPacketSize.

Remark: The buffer can be automatically validated or cleared by using the Buffer Length register (see [Table 106](#)).

Host to peripheral (OUT endpoint): After each read, an internal counter is automatically decremented, by two in 16-bit mode and one in 8-bit mode, to the next location in the RX FIFO. When all bytes have been read, the buffer contents are automatically cleared. A

new data packet can then be received on the next OUT token. Buffer contents can also be cleared through the Control Function register (bit CLBUF), whenever it is necessary to forcefully clear contents.

The Data Port register description when the ISP1763A is in 16-bit mode is given in [Table 105](#).

Table 105. DATA_PORT - Data Port register (address 20h) bit description

Legend: * reset value

Bit	Symbol	Access	Value	Description
15 to 0	DATA_PORT [15:0]	R/W	0000h*	Data port: A 500 ns delay starting from the reception of the endpoint interrupt may be required for the first read from the data port.

11.3.4 Buffer Length register

This register determines the current packet size (DATACOUNT) of the indexed endpoint FIFO. The bit allocation is given in [Table 106](#).

The Buffer Length register will be updated with the FIFO size register value whenever there is a write access to the Endpoint MaxPacketSize register (see [Table 109](#)). A smaller value can be written when required. After a bus reset, the Buffer Length register is made zero.

IN endpoint: When the data transfer is performed in multiples of MaxPacketSize, the Buffer Length register is not significant. This register is useful only when transferring data that is not a multiple of MaxPacketSize. The following two examples demonstrate the significance of the Buffer Length register.

Example 1: Consider that the transfer size is 512 bytes and MaxPacketSize is programmed as 64 bytes, the Buffer Length register need not be filled. This is because the transfer size is a multiple of MaxPacketSize, and MaxPacketSize packets will be automatically validated because the last packet is also of MaxPacketSize.

Example 2: Consider that the transfer size is 510 bytes and MaxPacketSize is programmed as 64 bytes, the Buffer Length register should be filled with 62 bytes just before the microcontroller writes the last packet of 62 bytes. This ensures that the last packet, which is a short packet of 62 bytes, is automatically validated.

Use the VENDP bit in the Control register if you are not using the Buffer Length register.

This is applicable only to the PIO mode access.

OUT endpoint: The DATACOUNT value is automatically initialized to the number of data bytes sent by the host on each ACK.

Remark: When using a 16-bit microprocessor bus, the last byte of an odd-sized packet is output as the lower byte (LSByte).

Table 106. BUFFER_LENGTH - Buffer Length register (address 1Ch) bit description

Legend: * reset value

Bit	Symbol	Access	Value	Description
15 to 0	DATACOUNT [15:0]	R/W	0000h*	Data count: Determines the current packet size of the indexed endpoint FIFO.

11.3.5 DcBufferStatus register

The endpoint index must first be set before accessing this register for the corresponding endpoint. It reflects the status of the endpoint FIFO. [Table 107](#) shows the bit allocation of the DcBufferStatus register.

Remark: Buffer 1 is filled first before filling up buffer 0.

Remark: This register is not applicable to the control endpoint.

Remark: For the endpoint IN data transfer, the firmware must ensure a 200 ns delay between writing of the data packet and reading the DcBufferStatus register. For the endpoint OUT data transfer, the firmware must also ensure a 200 ns delay between the reception of the endpoint interrupt and reading the DcBufferStatus register.

Table 107. DcBufferStatus - Device Controller Buffer Status register (address 1Eh) bit allocation

Bit	7	6	5	4	3	2	1	0
Symbol	reserved						BUF1	BUF0
Reset	0	0	0	0	0	0	0	0
Bus reset	0	0	0	0	0	0	0	0
Access	R	R	R	R	R	R	R	R

Table 108. DcBufferStatus - Device Controller Buffer Status register (address 1Eh) bit description

Bit	Symbol	Description
7 to 2	-	reserved
1 to 0	BUF[1:0]	Buffer: 00 — The buffers are not filled. 01 — One of the buffers is filled. 10 — One of the buffers is filled. 11 — Both the buffers are filled.

11.3.6 Endpoint MaxPacketSize register

This register determines the maximum packet size for all endpoints, except control endpoint 0. The register contains 2 bytes, and the bit allocation is given in [Table 109](#).

Each time the register is written, the Buffer Length registers of the corresponding endpoint is re-initialized to the FFOSZ field value. NTRANS bits control the number of transactions allowed in a single microframe for high-speed isochronous and interrupt endpoints only.

Table 109. ENDP_MAXPKTSIZE - Endpoint MaxPacketSize register (address 04h) bit allocation

Bit	15	14	13	12	11	10	9	8
Symbol	reserved ^[1]			NTRANS[1:0]		FFOSZ[10:8]		
Reset	0	0	0	0	0	0	0	0
Bus reset	0	0	0	0	0	0	0	0
Access	R/W	R/W	R/W	R/W	R/W	R/W	R/W	R/W
Bit	7	6	5	4	3	2	1	0
Symbol	FFOSZ[7:0]							

Bit	7	6	5	4	3	2	1	0
Reset	0	0	0	0	0	0	0	0
Bus reset	0	0	0	0	0	0	0	0
Access	R/W	R/W	R/W	R/W	R/W	R/W	R/W	R/W

[1] The reserved bits should always be written with the reset value.

Table 110. ENDP_MAXPKTSIZE - Endpoint MaxPacketSize register (address 04h) bit description

Bit	Symbol	Description
15 to 13	-	reserved
12 to 11	NTRANS[1:0]	<p>Number of transactions: HS mode only.</p> <p>00 — One packet per microframe.</p> <p>01 — Two packets per microframe.</p> <p>10 — Three packets per microframe.</p> <p>11 — reserved</p> <p>These bits are applicable only for isochronous or interrupt transactions.</p>
10 to 0	FFOSZ[10:0]	<p>FIFO size: Sets the FIFO size in bytes for the indexed endpoint. Applies to both high-speed and full-speed operations (see Table 111).</p>

The ISP1763A supports all the transfers given in *Universal Serial Bus Specification Rev. 2.0*.

Each programmable FIFO can be independently configured using its Endpoint MaxPacketSize register (R/W: 04h), but the total physical size of all enabled endpoints (IN plus OUT), including the set-up token buffer, control IN, and control OUT, must not exceed 4096 bytes.

11.3.7 Endpoint Type register

This register sets the endpoint type of the indexed endpoint: isochronous, bulk, or interrupt. It also serves to enable the endpoint and configure it for double buffering. Automatic generation of an empty packet for a zero-length TX buffer can be disabled using bit NOEMPKT. The register contains 2 bytes. See [Table 111](#).

Table 111. ENDP_TYPE - Endpoint Type register (address 08h) bit allocation

Bit	15	14	13	12	11	10	9	8
Symbol	reserved ^[1]							
Reset	0	0	0	0	0	0	0	0
Bus reset	0	0	0	0	0	0	0	0
Access	R/W	R/W	R/W	R/W	R/W	R/W	R/W	R/W
Bit	7	6	5	4	3	2	1	0
Symbol	reserved ^[1]			NOEMPKT	ENABLE	DBLBUF	ENDPTYP[1:0]	
Reset	0	0	0	0	0	0	0	0
Bus reset	0	0	0	0	0	0	0	0
Access	R/W	R/W	R/W	R/W	R/W	R/W	R/W	R/W

[1] The reserved bits should always be written with the reset value.

Table 112. ENDP_TYPE - Endpoint Type register (address 08h) bit description

Bit	Symbol	Description
15 to 5	-	reserved
4	NOEMPKT	No empty packet: Logic 0 causes the ISP1763A to return a null length packet for the IN token after the DMA IN transfer is complete. Set to logic 1 to disable the generation of the null length packet.
3	ENABLE	Endpoint enable: Logic 1 enables the FIFO of the indexed endpoint. The memory size is allocated as specified in the Endpoint MaxPacketSize register. Logic 0 disables the FIFO. Remark: Stalling a data endpoint will confuse the Data Toggle bit on the stalled endpoint because the internal logic picks up from where it has stalled. Therefore, the Data Toggle bit must be reset by disabling and re-enabling the corresponding endpoint (by setting bit ENABLE to logic 0, followed by logic 1 in the Endpoint Type register) to reset the PID.
2	DBLBUF	Double buffering: Logic 1 enables double buffering for the indexed endpoint. Logic 0 disables double buffering.
1 to 0	ENDPTYP [1:0]	Endpoint type: These bits select the endpoint type as follows. 00 — Not used 01 — Isochronous 10 — Bulk 11 — Interrupt

11.4 DMA registers

The Generic DMA (GDMA) transfer can be done by writing the proper opcode in the DMA Command register. The control bits are given in [Table 113](#).

GDMA read/write (opcode = 00h/01h) for Generic DMA slave mode

The GDMA (slave) can operate in counter mode. RD_N/DS_N/RE_N/OE_N and WR_N/RW_N/WE_N are DMA data strobe signals. These signals are also used as data strobe signals during the PIO access. An internal multiplex will redirect these signals to the DMA controller for the DMA transfer or to registers for the PIO access.

In counter mode, the DIS_XFER_CNT bit in the DcDMAConfiguration register must be set to logic 0. The DMA Transfer Counter register must be programmed before any DMA command is issued. The DMA transfer counter is set by writing from the LSByte to the MSByte (address: 34h to 37h). The internal DMA transfer counter is updated when the MSByte is written. Once the DMA transfer is started, the transfer counter starts decrementing and on reaching 0, the DMA_XFER_OK bit is set and an interrupt is generated by the ISP1763A.

The DMA transfer starts once the DMA command is issued. Any of the following three ways will terminate this DMA transfer:

- Detecting an internal EOT (short packet on an OUT token)
- Resetting the DMA
- GDMA stop command

There are two interrupts that are programmable to differentiate the method of DMA termination: the INT_EOT and DMA_XFER_OK bits in the DMA Interrupt Reason register. For details, see [Table 123](#).

Table 113. Control bits for GDMA read/write (opcode = 00h/01h)

Control bits	Description	Reference
DcDMAConfiguration register		
MODE[1:0]	Determines the active read or write data strobe signals	Table 119
WIDTH	Selects the DMA bus width: 16 or 8 bits	
DIS_XFER_CNT	Disables the use of the DMA Transfer Counter	
DMA Hardware register		
ACK_POL, DREQ_POL	Select the polarity of the DMA handshake signals	Table 122

Remark: The DMA bus defaults to 3-state, until a DMA command is executed. All the other control signals are not 3-stated.

11.4.1 DMA Command register

The DMA Command register is a 1-byte register (for bit allocation, see [Table 114](#)) that initiates all DMA transfer activities on the DMA controller. The register is write-only; reading it will return FFh.

Remark: The DMA bus will be in 3-state until a DMA command is executed.

Table 114. DMA_CMD - DMA Command register (address 30h) bit allocation

Bit	7	6	5	4	3	2	1	0
Symbol	DMA_CMD[7:0]							
Reset	1	1	1	1	1	1	1	1
Bus reset	1	1	1	1	1	1	1	1
Access	W	W	W	W	W	W	W	W

Table 115. DMA_CMD - DMA Command register (address 30h) bit description

Bit	Symbol	Description
7 to 0	DMA_CMD[7:0]	DMA command code; see Table 116 .

Table 116. DMA commands

Code	Name	Description
00h	GDMA Read	Generic DMA IN token transfer: Data is transferred from the external DMA bus to the internal buffer.
01h	GDMA Write	Generic DMA OUT token transfer: Data is transferred from the internal buffer to the external DMA bus.
02h to 0Dh	-	reserved
0Eh	Validate Buffer	Validate buffer: Request from the microcontroller to validate the endpoint buffer, following a DMA-to-USB data transfer.
0Fh	Clear Buffer	Clear buffer: Request from the microcontroller to clear the endpoint buffer, after a DMA-to-USB data transfer. It clears the TX buffer of the indexed endpoint; the RX buffer is not affected. The TX buffer is automatically cleared once data is sent on the USB bus. This command is issued only when it is necessary to forcefully clear the buffer. Remark: If using a double buffer, to clear both the buffers, issue the Clear Buffer command two times.
10h	-	reserved

Table 116. DMA commands ...continued

Code	Name	Description
11h	Reset DMA	Reset DMA: Initializes the DMA core to its power-on reset state. Remark: When the DMA core is reset during the Reset DMA command, the DREQ, DACK, RD_N/DS_N/RE_N/OE_N, and WR_N/RW_N/WE_N handshake pins will temporarily be asserted. This can confuse the external DMA controller. To prevent this, start the external DMA controller only after the DMA reset.
12h	-	reserved
13h	GDMA Stop	GDMA stop: This command stops the GDMA data transfer. Any data in the OUT endpoint that is not transferred by the DMA will remain in the buffer. The FIFO data for the IN endpoint will be written to the endpoint buffer. An interrupt bit will be set to indicate that the DMA Stop command is complete.
14h to FFh	-	reserved

11.4.2 DMA Transfer Counter register

This 4-byte register sets up the total byte count for a DMA transfer (DMACR). It indicates the remaining number of bytes left for transfer. The bit allocation is given in [Table 117](#).

For IN endpoint — Because there is a FIFO in the ISP1763A DMA controller, some data may remain in the FIFO during the DMA transfer. The maximum FIFO size is 8 bytes, and the maximum delay time for data to be shifted to endpoint buffer is 60 ns.

For OUT endpoint — Data will not be cleared for the endpoint buffer until all the data has been read from the DMA FIFO.

Table 117. DMA_XFR_CTR - DMA Transfer Counter register (address 34h) bit allocation

Bit	31	30	29	28	27	26	25	24
Symbol	DMACR4 = DMACR[31:24]							
Reset	0	0	0	0	0	0	0	0
Bus reset	0	0	0	0	0	0	0	0
Access	R/W	R/W	R/W	R/W	R/W	R/W	R/W	R/W
Bit	23	22	21	20	19	18	17	16
Symbol	DMACR3 = DMACR[23:16]							
Reset	0	0	0	0	0	0	0	0
Bus reset	0	0	0	0	0	0	0	0
Access	R/W	R/W	R/W	R/W	R/W	R/W	R/W	R/W
Bit	15	14	13	12	11	10	9	8
Symbol	DMACR2 = DMACR[15:8]							
Reset	0	0	0	0	0	0	0	0
Bus reset	0	0	0	0	0	0	0	0
Access	R/W	R/W	R/W	R/W	R/W	R/W	R/W	R/W
Bit	7	6	5	4	3	2	1	0
Symbol	DMACR1 = DMACR[7:0]							
Reset	0	0	0	0	0	0	0	0
Bus reset	0	0	0	0	0	0	0	0
Access	R/W	R/W	R/W	R/W	R/W	R/W	R/W	R/W

Table 118. DMA_XFR_CTR - DMA Transfer Counter register (address 34h) bit description

Bit	Symbol	Description
31 to 24	DMACR4, DMACR[31:24]	DMA counter 4: DMA transfer counter byte 4 (MSB)
23 to 16	DMACR3, DMACR[23:16]	DMA counter 3: DMA transfer counter byte 3
15 to 8	DMACR2, DMACR[15:8]	DMA counter 2: DMA transfer counter byte 2
7 to 0	DMACR1, DMACR[7:0]	DMA counter 1: DMA transfer counter byte 1 (LSB)

11.4.3 DcDMAConfiguration register

This register defines the DMA configuration for GDMA mode. The DcDMAConfiguration register consists of 2 bytes. The bit allocation is given in [Table 119](#).

Table 119. DcDMAConfiguration - Device Controller Direct Memory Access Configuration register (address 38h) bit allocation

Bit	15	14	13	12	11	10	9	8
Symbol	reserved ^[1]							
Reset	0	0	0	0	0	0	0	0
Bus reset	0	0	0	0	0	0	0	0
Access	R/W	R/W	R/W	R/W	R/W	R/W	R/W	R/W
Bit	7	6	5	4	3	2	1	0
Symbol	DIS_XFER_CNT	reserved ^[1]			MODE[1:0]		reserved ^[1]	WIDTH
Reset	0	0	0	0	0	0	0	1
Bus reset	0	0	0	0	0	0	0	1
Access	R/W	R/W	R/W	R/W	R/W	R/W	R/W	R/W

[1] The reserved bits should always be written with the reset value.

Table 120. DcDMAConfiguration - Device Controller Direct Memory Access Configuration register (address 38h) bit description

Bit ^[1]	Symbol	Description
15 to 8	-	reserved
7	DIS_XFER_CNT	Disable transfer counter: Write logic 0 to perform DMA operation. Logic 1 disables the DMA transfer counter (see Table 117).
6 to 4	-	reserved
3 to 2	MODE[1:0]	Mode: 00 — WR_N/RW_N/WE_N slave strobes data from the DMA bus into the ISP1763A; RD_N/DS_N/RE_N/OE_N slave puts data from the ISP1763A on the DMA bus 01, 10, 11 — reserved
1	-	reserved
0	WIDTH	Width: This bit selects the DMA bus width for the GDMA slave. 0 — 8-bit data bus 1 — 16-bit data bus Remark: Both this bit and bit DATA_BUS_WIDTH must be configured with the same bus width, for example, 16 bits or 8 bits.

[1] The DREQ pin will be driven only after you perform a write access to the DcDMAConfiguration register (that is, after you have configured the DcDMAConfiguration register).

11.4.4 DMA Hardware register

This register defines the DMA configuration for GDMA mode. The bit allocation is given in [Table 121](#).

Table 121. DMA_HW - DMA Hardware register (address 3Ch) bit allocation

Bit	7	6	5	4	3	2	1	0
Symbol	reserved ^[1]				DACK_POL	DREQ_POL	reserved ^[1]	
Reset	0	0	0	0	0	1	0	0
Bus reset	0	0	0	0	0	1	0	0
Access	R/W	R/W	R/W	R/W	R/W	R/W	R/W	R/W

[1] The reserved bits should always be written with the reset value.

Table 122. DMA_HW - DMA Hardware register (address 3Ch) bit description

Bit	Symbol	Description
7 to 4		reserved
3	DACK_POL	DACK polarity: Selects the DMA acknowledgment polarity. 0 — DACK is active LOW. 1 — DACK is active HIGH. Remark: Value written to this bit must be the same as the value written to bit DACK_POL in the HW Mode Control register (address B6h).
2	DREQ_POL	DREQ polarity: Selects the DMA request polarity. 0 — DREQ is active LOW. 1 — DREQ is active HIGH. Remark: Value written to this bit must be the same as the value written to bit DREQ_POL in the HW Mode Control register (address B6h).
1 to 0	-	reserved

11.4.5 DMA Interrupt Reason register

This 2-byte register shows the source(s) of the DMA interrupt. Each bit is refreshed after a DMA command is executed. An interrupt source is cleared by writing logic 1 to the corresponding bit. On detecting the interrupt, the external microprocessor must read the DMA Interrupt Reason register and mask it with the corresponding bits in the DMA Interrupt Enable register to determine the source of the interrupt.

The bit allocation is given in [Table 123](#).

Table 123. DMA_INTR_REASON - DMA Interrupt Reason register (address 50h) bit allocation

Bit	15	14	13	12	11	10	9	8
Symbol	reserved ^[1]			GDMA_STOP	reserved ^[1]	INT_EOT	reserved ^[1]	DMA_XFER_OK
Reset	0	0	0	0	0	0	0	0
Bus reset	0	0	0	0	0	0	0	0
Access	R/W	R/W	R/W	R/W	R/W	R/W	R/W	R/W

Bit	7	6	5	4	3	2	1	0
Symbol	reserved ^[1]							
Reset	0	0	0	0	0	0	0	0
Bus reset	0	0	0	0	0	0	0	0
Access	R/W	R/W	R/W	R/W	R/W	R/W	R/W	R/W

[1] The reserved bits should always be written with the reset value.

Table 124. DMA_INTR_REASON - DMA Interrupt Reason register (address 50h) bit description

Bit	Symbol	Description
15 to 13	-	reserved
12	GDMA_STOP	GDMA stop: When the GDMA_STOP command is issued to the DMA Command register, it means that the DMA transfer has successfully terminated.
11	-	reserved
10	INT_EOT	Internal EOT: Logic 1 indicates that an internal EOT is detected; see Table 125 .
9	-	reserved
8	DMA_XFER_OK	DMA transfer OK: Logic 1 indicates that the DMA transfer has been completed, that is, DMA transfer counter has become zero.
7 to 0	-	reserved

Table 125. Internal EOT-functional relation with bit DMA_XFER_OK

INT_EOT	DMA_XFER_OK	Description
1	0	During the DMA transfer, there is a premature termination with a short packet.
1	1	DMA transfer is completed with a short packet. The DMA transfer counter has reached 0.
0	1	DMA transfer is completed without any short packet. The DMA transfer counter has reached 0.

[Table 126](#) shows the status of the bits in the DMA Interrupt Reason register when the corresponding bits in the DcInterrupt register are set.

Table 126. Status of the bits in the DMA Interrupt Reason register

Status	INT_EOT ^[1]	DMA_XFER_OK ^[1]	
		Counter enabled	Counter disabled
IN full	0	1	0
IN short	0	1	0
OUT full	0	1	0
OUT short	1 ^[2]	1	0

[1] 1 indicates that the bit is set and 0 indicates that the bit is not set. A bit is set when the corresponding EOT condition is met.

[2] The value of INT_EOT may not be accurate if an external or internal transfer counter is programmed with a value that is lower than the transfer that the host requests. To terminate an OUT transfer with INT_EOT, the external or internal DMA counter should be programmed as a multiple of the full-packet length of the DMA endpoint. When a short packet is successfully transferred by DMA, INT_EOT is set.

11.4.6 DMA Interrupt Enable register

This 2-byte register controls the interrupt generation of the source bits in the DMA Interrupt Reason register. The bit allocation is given in [Table 127](#).

Logic 1 enables the interrupt generation. The values after a (bus) reset are logic 0 (disabled).

Table 127. DMA_INTR_EN - DMA Interrupt Enable register (address 54h) bit allocation

Bit	15	14	13	12	11	10	9	8
Symbol	reserved ^[1]			IE_GDMA_STOP	reserved ^[1]	IE_INT_EOT	reserved ^[1]	IE_DMA_XFER_OK
Reset	0	0	0	0	0	0	0	0
Bus reset	0	0	0	0	0	0	0	0
Access	R/W	R/W	R/W	R/W	R/W	R/W	R/W	R/W
Bit	7	6	5	4	3	2	1	0
Symbol	reserved ^[1]							
Reset	0	0	0	0	0	0	0	0
Bus reset	0	0	0	0	0	0	0	0
Access	R/W	R/W	R/W	R/W	R/W	R/W	R/W	R/W

[1] The reserved bits should always be written with the reset value.

Table 128. DMA_INTR_EN - DMA Interrupt Enable register (address 54h) bit description

Bit	Symbol	Description
15 to 13	-	reserved
12	IE_GDMA_STOP	Interrupt enable GDMA stop: Logic 1 enables the GDMA stop interrupt.
11	-	reserved
10	IE_INT_EOT	Interrupt enable internal EOT: Logic 1 enables the internal EOT interrupt.
9	-	reserved
8	IE_DMA_XFER_OK	Interrupt enable DMA transfer OK: Logic 1 enables the DMA transfer complete interrupt.
7 to 0	-	reserved

11.4.7 DMA Endpoint register

This 1-byte register selects a USB endpoint FIFO as a source or destination for DMA transfers. The bit allocation is given in [Table 129](#).

Table 129. DMA_ENDP - DMA Endpoint register (address 58h) bit allocation

Bit	7	6	5	4	3	2	1	0
Symbol	reserved ^[1]				EPIDX[2:0]			DMADIR
Reset	0	0	0	0	0	0	0	0
Bus reset	0	0	0	0	0	0	0	0
Access	R/W	R/W	R/W	R/W	R/W	R/W	R/W	R/W

[1] The reserved bits should always be written with the reset value.

Table 130. DMA_ENDP - DMA Endpoint register (address 58h) bit description

Bit	Symbol	Description
7 to 4	-	reserved
3 to 1	EPIDX[2:0]	Endpoint index: Selects the indicated endpoint for the DMA access
0	DMADIR	DMA direction: 0 — Selects the RX/OUT FIFO for DMA read transfers. 1 — Selects the TX/IN FIFO for DMA write transfers.

The DMA Endpoint register must not reference the endpoint that is indexed by the Endpoint Index register (2Ch) at any time. Doing so will result in data corruption. Therefore, if the DMA Endpoint register is unused, point it to an unused endpoint. If the DMA Endpoint register, however, is pointed to an active endpoint, the firmware must not reference the same endpoint on the Endpoint Index register.

11.4.8 DMA Burst Counter register

[Table 131](#) shows the bit allocation of the register.

Table 131. DMA_BRST_CTR - DMA Burst Counter register (address 64h) bit allocation

Bit	15	14	13	12	11	10	9	8
Symbol	reserved ^[1]			BURSTCOUNTER[12:8]				
Reset	0	0	0	0	0	0	0	0
Bus reset	0	0	0	0	0	0	0	0
Access	R/W	R/W	R/W	R/W	R/W	R/W	R/W	R/W
Bit	7	6	5	4	3	2	1	0
Symbol	BURSTCOUNTER[7:0]							
Reset	0	0	0	0	0	1	0	0
Bus reset	0	0	0	0	0	1	0	0
Access	R/W	R/W	R/W	R/W	R/W	R/W	R/W	R/W

[1] The reserved bits should always be written with the reset value.

Table 132. DMA_BRST_CTR - DMA Burst Counter register (address 64h) bit description

Bit	Symbol	Description
15 to 13	-	reserved
12 to 0	BURST COUNTER [12:0]	Burst counter: This register defines the burst length. The counter must be programmed to be a multiple of two in 16-bit mode and one in 8-bit mode. The value of the burst counter must be programmed so that the buffer counter is a factor of the burst counter. DREQ will drop when the number of bytes transferred equals to the burst counter at every DMA read or write cycle.

11.5 General registers

11.5.1 DcInterrupt register

The DcInterrupt register consists of 4 bytes. The bit allocation is given in [Table 133](#).

When a bit is set in the DcInterrupt register, it indicates that the hardware condition for an interrupt has occurred. When the DcInterrupt register content is non-zero, the INT output will be asserted. On detecting the interrupt, the external microprocessor must read the DcInterrupt register to determine the source of the interrupt.

Each endpoint buffer has a dedicated interrupt bit (EPnTX, EPnRX). In addition, various bus states can generate an interrupt: resume, suspend, pseudo SOF, SOF, and bus reset. The DMA controller has only one interrupt bit: the source for a DMA interrupt is shown in the DMA Interrupt Reason register.

Each interrupt bit can individually be cleared by writing logic 1. The DMA Interrupt bit can be cleared by writing logic 1 to the related interrupt source bit in the DMA Interrupt Reason register and writing logic 1 to the DMA bit of the DcInterrupt register.

Table 133. DcInterrupt - Device Controller Interrupt register (address 18h) bit allocation

Bit	31	30	29	28	27	26	25	24
Symbol	reserved ^[1]						EP7TX	EP7RX
Reset	0	0	0	0	0	0	0	0
Bus reset	0	0	0	0	0	0	0	0
Access	R/W	R/W	R/W	R/W	R/W	R/W	R/W	R/W
Bit	23	22	21	20	19	18	17	16
Symbol	EP6TX	EP6RX	EP5TX	EP5RX	EP4TX	EP4RX	EP3TX	EP3RX
Reset	0	0	0	0	0	0	0	0
Bus reset	0	0	0	0	0	0	0	0
Access	R/W	R/W	R/W	R/W	R/W	R/W	R/W	R/W
Bit	15	14	13	12	11	10	9	8
Symbol	EP2TX	EP2RX	EP1TX	EP1RX	EP0TX	EP0RX	reserved ^[1]	EP0SETUP
Reset	0	0	0	0	0	0	0	0
Bus reset	0	0	0	0	0	0	0	0
Access	R/W	R/W	R/W	R/W	R/W	R/W	R/W	R/W
Bit	7	6	5	4	3	2	1	0
Symbol	VBUS	DMA	HS_STAT	RESUME	SUSP	PSOF	SOF	BRESET
Reset	0	0	0	0	0	0	0	0
Bus reset	0	0	0	0	0	0	0	unchanged
Access	R/W	R/W	R/W	R/W	R/W	R/W	R/W	R/W

[1] The reserved bits should always be written with the reset value.

Table 134. DcInterrupt - Device Controller Interrupt register (address 18h) bit description

Bit	Symbol	Description
31 to 26	-	reserved
25	EP7TX	Endpoint 7 transmit: Logic 1 indicates the endpoint 7 TX buffer as the interrupt source.
24	EP7RX	Endpoint 7 receive: Logic 1 indicates the endpoint 7 RX buffer as the interrupt source.
23	EP6TX	Endpoint 6 transmit: Logic 1 indicates the endpoint 6 TX buffer as the interrupt source.
22	EP6RX	Endpoint 6 receive: Logic 1 indicates the endpoint 6 RX buffer as the interrupt source.
21	EP5TX	Endpoint 5 transmit: Logic 1 indicates the endpoint 5 TX buffer as the interrupt source.
20	EP5RX	Endpoint 5 receive: Logic 1 indicates the endpoint 5 RX buffer as the interrupt source.

Table 134. DcInterrupt - Device Controller Interrupt register (address 18h) bit description ...continued

Bit	Symbol	Description
19	EP4TX	Endpoint 4 transmit: Logic 1 indicates the endpoint 4 TX buffer as the interrupt source.
18	EP4RX	Endpoint 4 receive: Logic 1 indicates the endpoint 4 RX buffer as the interrupt source.
17	EP3TX	Endpoint 3 transmit: Logic 1 indicates the endpoint 3 TX buffer as the interrupt source.
16	EP3RX	Endpoint 3 receive: Logic 1 indicates the endpoint 3 RX buffer as the interrupt source.
15	EP2TX	Endpoint 2 transmit: Logic 1 indicates the endpoint 2 TX buffer as the interrupt source.
14	EP2RX	Endpoint 2 receive: Logic 1 indicates the endpoint 2 RX buffer as the interrupt source.
13	EP1TX	Endpoint 1 transmit: Logic 1 indicates the endpoint 1 TX buffer as the interrupt source.
12	EP1RX	Endpoint 1 receive: Logic 1 indicates the endpoint 1 RX buffer as the interrupt source.
11	EP0TX	Endpoint 0 transmit: Logic 1 indicates the endpoint 0 data TX buffer as the interrupt source.
10	EP0RX	Endpoint 0 receive: Logic 1 indicates the endpoint 0 data RX buffer as the interrupt source.
9	-	reserved
8	EP0SETUP	Endpoint 0 set-up: Logic 1 indicates that a set-up token was received on endpoint 0.
7	VBUS	V_{BUS}: Logic 1 indicates there is a polarity change on V _{BUS} .
6	DMA	DMA status: Logic 1 indicates a change in the DMA Interrupt Reason register.
5	HS_STAT	High-speed status: Logic 1 indicates a change from full-speed to high-speed mode (HS connection). This bit is not set when the system goes into the full-speed suspend.
4	RESUME	Resume status: Logic 1 indicates that a status change from suspend to resume (active) was detected.
3	SUSP	Suspend status: Logic 1 indicates that a status change from active to suspend was detected on the bus.
2	PSOF	Pseudo SOF interrupt: Logic 1 indicates that a pseudo SOF or μ SOF was received. Pseudo SOF is an internally generated clock signal (full-speed: 1 ms period, high-speed: 125 μ s period) that is not synchronized to the USB bus SOF or μ SOF.
1	SOF	SOF interrupt: Logic 1 indicates that a SOF or μ SOF was received.
0	BRESET	Bus reset: Logic 1 indicates that a USB bus reset was detected.

11.5.2 Chip ID register

This read-only register contains the chip identification and hardware version numbers. The firmware must check this information to determine functions and features supported. The bit allocation is shown in [Table 135](#).

Table 135. DcChipID - Device Controller Chip Identifier register (address 70h) bit description

Legend: * reset value

Bit	Symbol	Access	Value	Description
31 to 0	CHIPID[31:0]	R	0017 6320h*	Chip ID: This registers represents the hardware version number (20h) and the chip ID (1763h) for the peripheral controller.

11.5.3 Frame Number register

This read-only register contains the frame number of the last successfully received Start-Of-Frame (SOF). The register contains 2 bytes. The bit allocation is given in [Table 136](#).

Table 136. FRAME_NO - Frame Number register (address 74h) bit allocation

Bit	15	14	13	12	11	10	9	8
Symbol	reserved		MICROSOF[2:0]			SOFR[10:8]		
Reset	0	0	0	0	0	0	0	0
Bus reset	0	0	0	0	0	0	0	0
Access	R	R	R	R	R	R	R	R
Bit	7	6	5	4	3	2	1	0
Symbol	SOFR[7:0]							
Reset	0	0	0	0	0	0	0	0
Bus reset	0	0	0	0	0	0	0	0
Access	R	R	R	R	R	R	R	R

Table 137. FRAME_NO - Frame Number register (address 74h) bit description

Bit	Symbol	Description
15 to 14	-	reserved
13 to 11	MICROSOF[2:0]	μSOFR received: Microframe number of the last successfully received SOF.
10 to 0	SOFR[10:0]	SOF received: Frame number of the last successfully received SOF.

11.5.4 Scratch register

This 16-bit register can be used by the firmware to save and restore information. For example, the device status before it enters the suspend state; see [Table 138](#).

Table 138. SCRATCH - Scratch register (address 78h) bit allocation

Bit	15	14	13	12	11	10	9	8
Symbol	SFIRH[7:0]							
Reset	0	0	0	0	0	0	0	0
Bus reset	unchanged							
Access	R/W	R/W	R/W	R/W	R/W	R/W	R/W	R/W
Bit	7	6	5	4	3	2	1	0
Symbol	SFIRL[7:0]							
Reset	0	0	0	0	0	0	0	0
Bus reset	unchanged							
Access	R/W	R/W	R/W	R/W	R/W	R/W	R/W	R/W

Table 139. SCRATCH - Scratch register (address 78h) bit description

Bit	Symbol	Description
15 to 8	SFIRH[7:0]	Scratch firmware information register (higher byte)
7 to 0	SFIRL[7:0]	Scratch firmware information register (lower byte)

11.5.5 Unlock Device register

To protect registers from getting corrupted when the ISP1763A goes into suspend, the write operation is disabled. In this case, when the chip resumes, the Unlock Device command must first be issued to this register before attempting to write to the rest of the registers. This is done by writing unlock code (AA37h) to this register. The bit allocation of the Unlock Device register is given in [Table 140](#).

Table 140. UNLOCK_DEV - Unlock Device register (address 7Ch) bit allocation

Bit	15	14	13	12	11	10	9	8
Symbol	ULCODE[15:8] = AAh							
Reset	not applicable							
Bus reset	not applicable							
Access	W	W	W	W	W	W	W	W
Bit	7	6	5	4	3	2	1	0
Symbol	ULCODE[7:0] = 37h							
Reset	not applicable							
Bus reset	not applicable							
Access	W	W	W	W	W	W	W	W

Table 141. UNLOCK_DEV - Unlock Device register (address 7Ch) bit description

Bit	Symbol	Description
15 to 0	ULCODE[15:0]	Unlock code: Writing data AA37h unlocks internal registers and FIFOs for writing, following a resume.

11.5.6 Interrupt Pulse Width register

[Table 142](#) shows the bit description of the register.

Table 142. INTR_PULSE_WIDTH - Interrupt Pulse Width register (address 80h) bit description

Legend: * reset value

Bit	Symbol	Access	Value	Description
15 to 0	INTR_PULSE_WIDTH[15:0]	R/W	1Eh*	Interrupt pulse width: The interrupt signal pulse width is configurable while it is in pulse signaling mode. The minimum pulse width is 33.3 ns when this register value is 1. The power-on reset value of 1Eh allows a pulse of 1 μ s to be generated.

11.5.7 Test Mode register

This 1-byte register allows the firmware to set the DP and DM pins to predetermined states for testing purposes. The bit allocation is given in [Table 143](#).

Remark: Only one bit can be set to logic 1 at a time.

Table 143. TEST_MODE - Test Mode register (address 84h) bit allocation

Bit	7	6	5	4	3	2	1	0
Symbol	FORCEHS	reserved ^[1]	FORCEFS	PRBS	KSTATE	JSTATE	SE0_NAK	
Reset	0	0	0	0	0	0	0	0
Bus reset	0	0	0	0	0	0	0	0
Access	R/W	R/W	R/W	R/W	R/W	R/W	R/W	R/W

[1] The reserved bits should always be written with the reset value.

Table 144. TEST_MODE - Test Mode register (address 84h) bit description

Bit	Symbol	Description
7	FORCEHS	Force high-speed: Logic 1 ^[1] forces the hardware to high-speed mode only and disables the chirp detection logic.
6 to 5	-	reserved.
4	FORCEFS	Force full-speed: Logic 1 ^[1] forces the physical layer to full-speed mode only and disables the chirp detection logic.
3	PRBS	Predetermined random pattern: Logic 1 ^[2] sets the DP and DM pins to toggle in a predetermined random pattern.
2	KSTATE	K state: Writing logic 1 ^[2] sets the DP and DM pins to the K state.
1	JSTATE	J state: Writing logic 1 ^[2] sets the DP and DM pins to the J state.
0	SE0_NAK	SE0 NAK: Writing logic 1 ^[2] sets the DP and DM pins to a high-speed quiescent state. The device only responds to a valid high-speed IN token with a NAK.

[1] Either FORCEHS or FORCEFS must be set at a time.

[2] Of the four bits (PRBS, KSTATE, JSTATE, and SE0_NAK), only one bit must be set at a time.

12. Limiting values

Table 145. Limiting values

In accordance with the Absolute Maximum Rating System (IEC 60134).

Symbol	Parameter	Conditions	Min	Max	Unit
$V_{CC(I/O)}$	input/output supply voltage		-0.5	+4.6	V
$V_{CC(3V3)}$	supply voltage		-0.5	+4.6	V
V_I	input voltage	on pin X1/CLKIN	-0.5	+2.5	V
		on pins DP1, DM1, DP2, DM2, ID	-0.5	+4.6	V
		on pins OC1/ V_{BUS1} , OC2/ V_{BUS2} , PSW1_N, PSW2_N	-0.5	+5.5	V
		other digital I/O pins	-0.5	$V_{CC(I/O)} + 0.5$	V
I_{lu}	latch-up current	$V_I < 0$ V or $V_I > V_{CC(3V3)}$	-	100	mA
V_{esd}	electrostatic discharge voltage	$I_{LI} < 1$ μ A; human body model (JESD22-A114-B)	-2000	+2000	V
		$I_{LI} < 1$ μ A; machine model (JESD22-A115-A)	-	+200	V
T_{stg}	storage temperature		-40	+125	$^{\circ}$ C

13. Recommended operating conditions

Table 146. Recommended operating conditions

Symbol	Parameter	Conditions	Min	Typ	Max	Unit
$V_{CC(I/O)}$	input/output supply voltage	$V_{CC(I/O)} = 3.3$ V	3.0	3.3	3.6	V
		$V_{CC(I/O)} = 1.8$ V	1.65	1.8	1.95	V
$V_{CC(3V3)}$	supply voltage		3.0	-	3.6	V
V_I	input voltage	on pin X1/CLKIN	0	1.2	1.3	V
		on pins DP1, DM1, DP2, DM2, ID	0	-	3.6	V
		on pins OC1/ V_{BUS1} , OC2/ V_{BUS2} , PSW1_N, PSW2_N	0	-	5.25	V
		other digital I/O pins	-	-	$V_{CC(I/O)}$	V
T_{amb}	ambient temperature		-40	-	+85	$^{\circ}$ C
T_j	junction temperature		-40	-	+125	$^{\circ}$ C

14. Static characteristics

Table 147. Static characteristics: supply pins

$V_{CC(3V3)} = 3.0\text{ V to }3.6\text{ V}$; $V_{CC(I/O)} = 1.65\text{ V to }1.95\text{ V or }3.0\text{ V to }3.6\text{ V}$; $T_{amb} = -40\text{ }^{\circ}\text{C to }+85\text{ }^{\circ}\text{C}$; unless otherwise specified. Typical case refers to $V_{CC(3V3)} = 3.3\text{ V}$, $V_{CC(I/O)} = 3.3\text{ V}$; $T_{amb} = +25\text{ }^{\circ}\text{C}$; unless otherwise specified.

Symbol	Parameter	Conditions	Min	Typ	Max	Unit
$I_{CC(3V3)}$	supply current	power-down mode ^[1]	-	2	20	μA
		deep sleep mode	-	150	350	μA
		host mode; bus idle	-	20	-	mA
		host mode; one port working (high-speed)	-	36	-	mA
		host mode; two ports working (high-speed)	-	55	-	mA
$I_{CC(I/O)}$	supply current on $V_{CC(I/O)}$	static; no bus activity	-	-	20	μA

[1] When the I/O pins are in definite state.

Table 148. Static characteristics: digital pins

$V_{CC(3V3)} = 3.0\text{ V to }3.6\text{ V}$; $V_{CC(I/O)} = 1.65\text{ V to }1.95\text{ V or }3.0\text{ V to }3.6\text{ V}$; $T_{amb} = -40\text{ }^{\circ}\text{C to }+85\text{ }^{\circ}\text{C}$; unless otherwise specified. Typical case refers to $V_{CC(3V3)} = 3.3\text{ V}$, $V_{CC(I/O)} = 3.3\text{ V}$; $T_{amb} = +25\text{ }^{\circ}\text{C}$; unless otherwise specified.

Symbol	Parameter	Conditions	Min	Typ	Max	Unit
V_{IH}	HIGH-level input voltage		$0.7V_{CC(I/O)}$	-	-	V
V_{IL}	LOW-level input voltage		-	-	$0.3V_{CC(I/O)}$	V
V_{hys}	hysteresis voltage		0.4	-	0.7	V
V_{OL}	LOW-level output voltage	$I_{OL} = 1.5\text{ mA}$ when $V_{CC(I/O)} = 1.65\text{ V to }1.95\text{ V}$	-	-	0.4	V
		$I_{OL} = 3.0\text{ mA}$ when $V_{CC(I/O)} = 3.0\text{ V to }3.6\text{ V}$	-	-	0.4	V
V_{OH}	HIGH-level output voltage	$I_{OH} = 3.3\text{ mA}$ when $V_{CC(I/O)} = 1.65\text{ V to }1.95\text{ V}$	$V_{CC(I/O)} - 0.4$	-	-	V
		$I_{OH} = 6.5\text{ mA}$ when $V_{CC(I/O)} = 3.0\text{ V to }3.6\text{ V}$	$V_{CC(I/O)} - 0.4$	-	-	V
I_{LI}	input leakage current	$V_I = 0\text{ V to }V_{CC(I/O)}$; push-pull pins	-	-	1	μA
		open-drain pins	-	-	20	μA
C_{in}	input capacitance		-	-	3	pF

Table 149. Static characteristics: USB interface block (pins DM1, DM2, DP1, DP2)

$V_{CC(3V3)} = 3.0\text{ V to }3.6\text{ V}$; $V_{CC(I/O)} = 1.65\text{ V to }1.95\text{ V or }3.0\text{ V to }3.6\text{ V}$; $T_{amb} = -40\text{ }^{\circ}\text{C to }+85\text{ }^{\circ}\text{C}$; unless otherwise specified. Typical case refers to $V_{CC(3V3)} = 3.3\text{ V}$, $V_{CC(I/O)} = 3.3\text{ V}$; $T_{amb} = +25\text{ }^{\circ}\text{C}$; unless otherwise specified.

Symbol	Parameter	Conditions	Min	Typ	Max	Unit
Input levels for high-speed						
V_{HSSQ}	high-speed squelch detection threshold voltage (differential signal amplitude)	squelch detected	-	-	100	mV
		no squelch detected	150	-	-	mV
V_{HSDSC}	high-speed disconnect detection threshold voltage (differential signal amplitude)	disconnect detected	625	-	-	mV
		disconnect not detected	-	-	525	mV

Table 149. Static characteristics: USB interface block (pins DM1, DM2, DP1, DP2) ...continued

$V_{CC(3V3)} = 3.0\text{ V to }3.6\text{ V}$; $V_{CC(I/O)} = 1.65\text{ V to }1.95\text{ V or }3.0\text{ V to }3.6\text{ V}$; $T_{amb} = -40\text{ °C to }+85\text{ °C}$; unless otherwise specified. Typical case refers to $V_{CC(3V3)} = 3.3\text{ V}$, $V_{CC(I/O)} = 3.3\text{ V}$; $T_{amb} = +25\text{ °C}$; unless otherwise specified.

Symbol	Parameter	Conditions	Min	Typ	Max	Unit
V_{HSCM}	high-speed data signaling common mode voltage range (guideline for receiver)		-50	-	+500	mV
Output levels for high-speed						
V_{HSOI}	high-speed idle level voltage		-10	-	+10	mV
V_{HSOH}	high-speed data signaling HIGH-level voltage		360	-	440	mV
V_{HSOL}	high-speed data signaling LOW-level voltage		-10	-	+10	mV
V_{CHIRPJ}	chirp J level (differential voltage)		700 ^[1]	-	1100	mV
V_{CHIRPK}	chirp K level (differential voltage)		-900 ^[1]	-	-500	mV
Input levels for full-speed and low-speed						
V_{IH}	HIGH-level input voltage	drive	2.0	-	-	V
V_{IHZ}	HIGH-level input voltage	floating	2.7	-	3.6	V
V_{IL}	LOW-level input voltage		-	-	0.8	V
V_{DI}	differential input sensitivity	$ V_{DP} - V_{DM} $	0.2	-	-	V
V_{CM}	differential common mode voltage range		0.8	-	2.5	V
Output levels for full-speed and low-speed						
V_{OH}	HIGH-level output voltage		2.8	-	3.6	V
V_{OL}	LOW-level output voltage		0	-	0.3	V
V_{CRS}	output signal crossover voltage		1.3	-	2.0	V
Impedance						
Z_{DRV}	driver output impedance	includes the R_S resistor	40.5	45	49.5	Ω

[1] The HS termination resistor is disabled, and the pull-up resistor is connected. Only during reset, when both the hub and the device are capable of the high-speed operation.

Table 150. Static characteristics: V_{BUS} comparators

$V_{CC(3V3)} = 3.0\text{ V to }3.6\text{ V}$; $V_{CC(I/O)} = 1.65\text{ V to }1.95\text{ V or }3.0\text{ V to }3.6\text{ V}$; $T_{amb} = -40\text{ °C to }+85\text{ °C}$; unless otherwise specified. Typical case refers to $V_{CC(3V3)} = 3.3\text{ V}$, $V_{CC(I/O)} = 3.3\text{ V}$; $T_{amb} = +25\text{ °C}$; unless otherwise specified.

Symbol	Parameter	Conditions	Min	Typ	Max	Unit
$V_{A_VBUS_VLD}$	A-device V_{BUS} valid voltage		-	4.5	-	V
$V_{A_SESS_VLD}$	A-device session valid voltage		0.8	1.6	2.0	V
$V_{hys(A_SESS_VLD)}$	A-device session valid hysteresis voltage		-	210	-	mV
$V_{B_SESS_VLD}$	B-device session valid voltage		2.0	3.6	4.0	V
$V_{hys(B_SESS_VLD)}$	B-device session valid hysteresis voltage		-	220	-	mV
$V_{B_SESS_END}$	B-device session end voltage		0.2	0.5	0.8	V
$V_{hys(B_SESS_END)}$	B-device session end hysteresis voltage		-	160	-	mV

Table 151. Static characteristics: V_{BUS} resistors

$V_{CC(3V3)} = 3.0\text{ V to }3.6\text{ V}$; $V_{CC(I/O)} = 1.65\text{ V to }1.95\text{ V or }3.0\text{ V to }3.6\text{ V}$; $T_{amb} = -40\text{ °C to }+85\text{ °C}$; unless otherwise specified. Typical case refers to $V_{CC(3V3)} = 3.3\text{ V}$, $V_{CC(I/O)} = 3.3\text{ V}$; $T_{amb} = +25\text{ °C}$; unless otherwise specified.

Symbol	Parameter	Conditions	Min	Typ	Max	Unit
R _{UP(VBUS)}	pull-up resistance on pin OC1/V _{BUS1}	connect to V _{CC(3V3)} when V _{BUS_CHRG} = 1	-	1.2	-	kΩ
R _{DN(VBUS)}	pull-down resistance on pin OC1/V _{BUS1}	connect to ground when V _{BUS_DISCHRG} = 1	-	1.8	-	kΩ
R _{I(idle)(VBUS)}	idle input resistance on pin OC1/V _{BUS1}		40 ^[1]	65	100	kΩ

[1] The V_{BUS} input impedance may be lower than 40 kΩ for a short period of time when V_{BUS} rises above V_{CC(3V3)}.

Table 152. Static characteristics: ID detection circuit

$V_{CC(3V3)} = 3.0\text{ V to }3.6\text{ V}$; $V_{CC(I/O)} = 1.65\text{ V to }1.95\text{ V or }3.0\text{ V to }3.6\text{ V}$; $T_{amb} = -40\text{ °C to }+85\text{ °C}$; unless otherwise specified. Typical case refers to $V_{CC(3V3)} = 3.3\text{ V}$, $V_{CC(I/O)} = 3.3\text{ V}$; $T_{amb} = +25\text{ °C}$; unless otherwise specified.

Symbol	Parameter	Conditions	Min	Typ	Max	Unit
V _{th(ID)}	ID detector threshold voltage		1.0	-	2.0	V
R _{UP(ID)}	ID pull-up resistance	bit ID_PULLUP = 1	-	20	-	kΩ

15. Dynamic characteristics

Table 153. Dynamic characteristics: system clock

$V_{CC(3V3)} = 3.0\text{ V to }3.6\text{ V}$; $V_{CC(I/O)} = 1.65\text{ V to }1.95\text{ V or }3.0\text{ V to }3.6\text{ V}$; $T_{amb} = -40\text{ °C to }+85\text{ °C}$; unless otherwise specified. Typical case refers to $V_{CC(3V3)} = 3.3\text{ V}$, $V_{CC(I/O)} = 3.3\text{ V}$; $T_{amb} = +25\text{ °C}$; unless otherwise specified.

Symbol	Parameter	Conditions	Min	Typ	Max	Unit
Crystal oscillator						
f_{clk}	clock frequency	FREQSEL2 = 0, FREQSEL1 = 0	[1] -	12	-	MHz
		FREQSEL2 = 0, FREQSEL1 = 1	[1] -	19.2	-	MHz
		FREQSEL2 = 1, FREQSEL1 = 0	[1] -	24	-	MHz
External clock input						
J	external clock jitter		-	-	500	ps
δ	clock duty cycle		-	50	-	%
$V_{i(X1/CLKIN)}$	input voltage on pin X1/CLKIN		-	1.2	-	V
t_r	rise time		-	-	3	ns
t_f	fall time		-	-	3	ns

[1] Recommended accuracy of the clock frequency is 50 ppm for the crystal and the oscillator.

Table 154. Dynamic characteristics: power-up and reset

$V_{CC(3V3)} = 3.0\text{ V to }3.6\text{ V}$; $V_{CC(I/O)} = 1.65\text{ V to }1.95\text{ V or }3.0\text{ V to }3.6\text{ V}$; $T_{amb} = -40\text{ °C to }+85\text{ °C}$; unless otherwise specified. Typical case refers to $V_{CC(3V3)} = 3.3\text{ V}$, $V_{CC(I/O)} = 3.3\text{ V}$; $T_{amb} = +25\text{ °C}$; unless otherwise specified.

Symbol	Parameter	Conditions	Min	Typ	Max	Unit
$t_{DMY_RD(RESET_N)}$	active-LOW reset to dummy read operation	regulator filter capacitor $C_{REG(1V2)} = 4.7\text{ }\mu\text{F}$	10	-	-	ms
$t_{DMY_RD(RESET)}$	active-HIGH reset to dummy read operation	regulator filter capacitor $C_{REG(1V2)} = 4.7\text{ }\mu\text{F}$	0	-	-	ns
$t_{OPR_RD(DMY_RD)}$	dummy read to first valid read operation	regulator filter capacitor $C_{REG(1V2)} = 4.7\text{ }\mu\text{F}$	10	-	-	ms

Table 155. Dynamic characteristics: digital pins

$V_{CC(3V3)} = 3.0\text{ V to }3.6\text{ V}$; $V_{CC(I/O)} = 1.65\text{ V to }1.95\text{ V or }3.0\text{ V to }3.6\text{ V}$; $T_{amb} = -40\text{ °C to }+85\text{ °C}$; unless otherwise specified. Typical case refers to $V_{CC(3V3)} = 3.3\text{ V}$, $V_{CC(I/O)} = 3.3\text{ V}$; $T_{amb} = +25\text{ °C}$; unless otherwise specified.

Symbol	Parameter	Conditions	Min	Typ	Max	Unit
SR	slew rate	standard load (rise, fall)	1	-	4	V/ns

Table 156. Dynamic characteristics: high-speed source electrical

$V_{CC(3V3)} = 3.0\text{ V to }3.6\text{ V}$; $V_{CC(I/O)} = 1.65\text{ V to }1.95\text{ V or }3.0\text{ V to }3.6\text{ V}$; $T_{amb} = -40\text{ °C to }+85\text{ °C}$; unless otherwise specified. Typical case refers to $V_{CC(3V3)} = 3.3\text{ V}$, $V_{CC(I/O)} = 3.3\text{ V}$; $T_{amb} = +25\text{ °C}$; unless otherwise specified.

Symbol	Parameter	Conditions	Min	Typ	Max	Unit
Driver characteristics						
t_{HSR}	rise time (10% to 90%)		500	-	-	ps
t_{HSF}	fall time (10% to 90%)		500	-	-	ps

Table 156. Dynamic characteristics: high-speed source electrical ...continued

$V_{CC(3V3)} = 3.0\text{ V to }3.6\text{ V}$; $V_{CC(I/O)} = 1.65\text{ V to }1.95\text{ V or }3.0\text{ V to }3.6\text{ V}$; $T_{amb} = -40\text{ }^{\circ}\text{C to }+85\text{ }^{\circ}\text{C}$; unless otherwise specified. Typical case refers to $V_{CC(3V3)} = 3.3\text{ V}$, $V_{CC(I/O)} = 3.3\text{ V}$; $T_{amb} = +25\text{ }^{\circ}\text{C}$; unless otherwise specified.

Symbol	Parameter	Conditions	Min	Typ	Max	Unit
Clock timing						
t _{HSDRAT}	high-speed data rate		479.76	-	480.24	Mbit/s
t _{HSFRAM}	microframe interval		124.9375	-	125.0625	μs
t _{HSRFI}	consecutive microframe interval difference		1	-	four high-speed bit times	ns

Table 157. Dynamic characteristics: full-speed source electrical

$V_{CC(3V3)} = 3.0\text{ V to }3.6\text{ V}$; $V_{CC(I/O)} = 1.65\text{ V to }1.95\text{ V or }3.0\text{ V to }3.6\text{ V}$; $T_{amb} = -40\text{ }^{\circ}\text{C to }+85\text{ }^{\circ}\text{C}$; unless otherwise specified. Typical case refers to $V_{CC(3V3)} = 3.3\text{ V}$, $V_{CC(I/O)} = 3.3\text{ V}$; $T_{amb} = +25\text{ }^{\circ}\text{C}$; unless otherwise specified.

Symbol	Parameter	Conditions	Min	Typ	Max	Unit
Driver characteristics						
t _{FR}	rise time	C _L = 50 pF; 10% to 90% of V _{OH} - V _{OL}	4	-	20	ns
t _{FF}	fall time	C _L = 50 pF; 90% to 10% of V _{OH} - V _{OL}	4	-	20	ns
t _{FRFM}	differential rise and fall time matching		90	-	111.1	%

Data timing: see Figure 9

t _{FDEOP}	source jitter for differential transition to SE0 transition	full-speed timing	-2	-	+5	ns
t _{FEOPT}	source SE0 interval of EOP		160	-	175	ns
t _{FEOPR}	receiver SE0 interval of EOP		82	-	-	ns
t _{LDEOP}	upstream facing port source jitter for differential transition to SE0 transition	low-speed timing	-40	-	+100	ns
t _{LEOPT}	source SE0 interval of EOP		1.25	-	1.5	μs
t _{LEOPR}	receiver SE0 interval of EOP		670	-	-	ns
t _{FST}	width of SE0 interval during differential transition		-	-	14	ns

Table 158. Dynamic characteristics: low-speed source electrical

$V_{CC(3V3)} = 3.0\text{ V to }3.6\text{ V}$; $V_{CC(I/O)} = 1.65\text{ V to }1.95\text{ V or }3.0\text{ V to }3.6\text{ V}$; $T_{amb} = -40\text{ }^{\circ}\text{C to }+85\text{ }^{\circ}\text{C}$; unless otherwise specified. Typical case refers to $V_{CC(3V3)} = 3.3\text{ V}$, $V_{CC(I/O)} = 3.3\text{ V}$; $T_{amb} = +25\text{ }^{\circ}\text{C}$; unless otherwise specified.

Symbol	Parameter	Conditions	Min	Typ	Max	Unit
Driver characteristics						
t _{LR}	transition time: rise time		75	-	300	ns
t _{LF}	transition time: fall time		75	-	300	ns
t _{LRFM}	rise and fall time matching		90	-	125	%

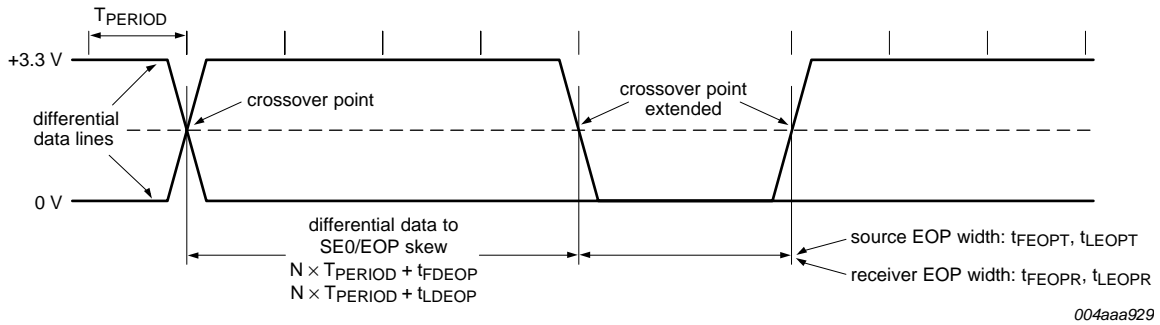

T_{PERIOD} is the bit duration corresponding to the USB data rate.

Fig 9. USB source differential data-to-EOP transition skew and EOP width

15.1 Timing

15.1.1 DMA

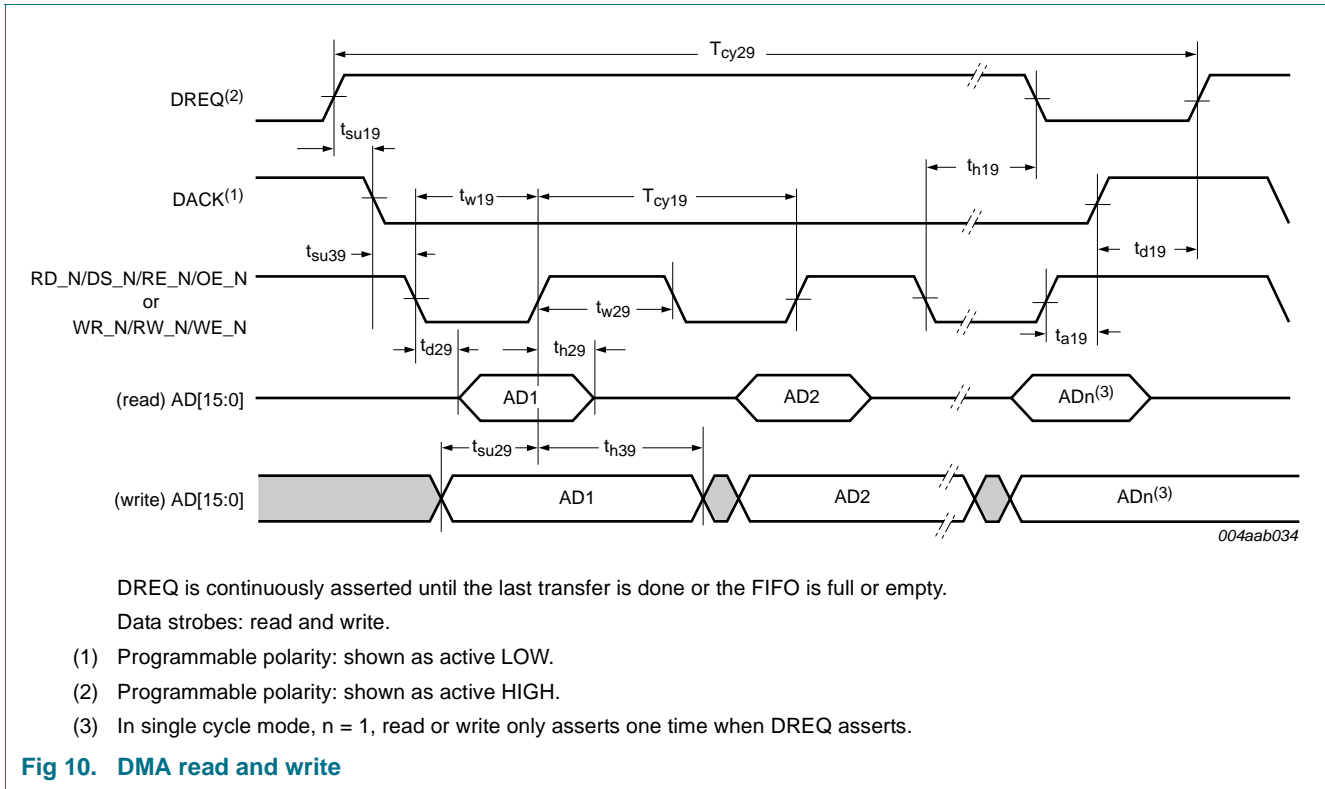

Table 159. DMA timing

$V_{CC(3V3)} = 3.0\text{ V to }3.6\text{ V}$; $V_{CC(I/O)} = 1.65\text{ V to }1.95\text{ V or }3.0\text{ V to }3.6\text{ V}$; $T_{amb} = -40\text{ }^{\circ}\text{C to }+85\text{ }^{\circ}\text{C}$; unless otherwise specified.
Typical case refers to $V_{CC(3V3)} = 3.3\text{ V}$, $V_{CC(I/O)} = 3.3\text{ V}$; $T_{amb} = +25\text{ }^{\circ}\text{C}$; unless otherwise specified.

Symbol	Parameter description	Host DMA		Peripheral DMA		Unit
		Min	Max	Min	Max	
t_{su19}	DREQ set-up time before DACK assertion	0	-	0	-	ns
t_{d19}	DACK deassertion to next DREQ assertion time	56	-	82	-	ns
t_{h19}	DREQ hold time after last strobe assertion	0	53	0	53	ns
t_{w19}	RD_N/DS_N/RE_N/OE_N or WR_N/RW_N/WE_N pulse width	25	-	40	-	ns
t_{w29}	RD_N/DS_N/RE_N/OE_N or WR_N/RW_N/WE_N recovery time	21	-	35	-	ns
t_{d29}	data valid time after RD_N/DS_N/RE_N/OE_N assertion	-	30	-	30	ns
t_{h29}	read data hold time after RD_N/DS_N/RE_N/OE_N deassertion	2	10	2	10	ns
t_{h39}	write data hold time after WR_N/RW_N/WE_N deassertion	0	-	0	-	ns
t_{su29}	write data set-up time before WR_N/RW_N/WE_N deassertion	10	-	10	-	ns

Table 159. DMA timing ...continued

$V_{CC(3V3)} = 3.0\text{ V to }3.6\text{ V}$; $V_{CC(I/O)} = 1.65\text{ V to }1.95\text{ V or }3.0\text{ V to }3.6\text{ V}$; $T_{amb} = -40\text{ }^{\circ}\text{C to }+85\text{ }^{\circ}\text{C}$; unless otherwise specified.
 Typical case refers to $V_{CC(3V3)} = 3.3\text{ V}$, $V_{CC(I/O)} = 3.3\text{ V}$; $T_{amb} = +25\text{ }^{\circ}\text{C}$; unless otherwise specified.

Symbol	Parameter description	Host DMA		Peripheral DMA		Unit
		Min	Max	Min	Max	
t_{su39}	DACK set-up time before RD_N/DS_N/RE_N/OE_N or WR_N/RW_N/WE_N assertion	0	-	0	-	ns
t_{a19}	DACK deassertion after RD_N/DS_N/RE_N/OE_N or WR_N/RW_N/WE_N deassertion	0	-	0	-	ns
T_{cy19}	DMA read/write cycle time	51	-	75	-	ns
T_{cy29}	DMA request cycle time	104	-	104	-	ns

15.1.2 PIO

Table 160. PIO timing

$V_{CC(3V3)} = 3.0\text{ V to }3.6\text{ V}$; $V_{CC(I/O)} = 3.0\text{ V to }3.6\text{ V}$; $T_{amb} = -40\text{ }^{\circ}\text{C to }+85\text{ }^{\circ}\text{C}$; unless otherwise specified.
 Typical case refers to $V_{CC(3V3)} = 3.3\text{ V}$, $V_{CC(I/O)} = 3.3\text{ V}$; $T_{amb} = +25\text{ }^{\circ}\text{C}$; unless otherwise specified.

Symbol	Parameter description	Condition	SRAM mode		Multiplex mode		Unit
			Min	Max	Min	Max	
t_{CS}	CS_N/CE_N set-up time before WR_N/RW_N/WE_N or RD_N/DS_N/RE_N/OE_N LOW		0	-	0	-	ns
t_{CH}	CS_N/CE_N hold time after WR_N/RW_N/WE_N or RD_N/DS_N/RE_N/OE_N HIGH		0	-	0	-	ns
t_{CP}	CS_N/CE_N pulse width for read		30	-	30	-	ns
	CS_N/CE_N pulse width for write		17	-	17	-	ns
$t_{CSADVAL}$	CS_N/CE_N set-up time before address latch		-	-	6	-	ns
t_{ASRW}	address set-up time before WR_N/RW_N/WE_N or RD_N/DS_N/RE_N/OE_N LOW		0	-	-	-	ns
t_{AHRW}	address hold time after WR_N/RW_N/WE_N or RD_N/DS_N/RE_N/OE_N LOW		10	-	-	-	ns
t_{AH}	address hold time after address latch		-	-	0	-	ns
t_{AS}	address set-up time before address latch		-	-	10	-	ns
t_{AP}	address latch pulse width		-	-	17	-	ns
t_{WC}	write cycle time	host or OTG	38	-	68	-	ns
		peripheral	100	-	100	-	ns
t_{WP}	WR_N/RW_N/WE_N pulse width		17	-	17	-	ns
t_{DH}	RD_N/DS_N/RE_N/OE_N HIGH to output Hi-Z		1	10	1	10	ns
	WR_N/RW_N/WE_N HIGH to input Hi-Z		0	-	0	-	ns
t_{DADVH}	data set-up time before data latch		10	-	10	-	ns
t_{OE}	RD_N/DS_N/RE_N/OE_N LOW to data output enable		2	-	2	-	ns
t_{BDS}	ready to WR_N/RW_N/WE_N or RD_N/DS_N/RE_N/OE_N LOW		-	-	5	-	ns

Table 160. PIO timing ...continued

$V_{CC(3V3)} = 3.0\text{ V to }3.6\text{ V}$; $V_{CC(I/O)} = 3.0\text{ V to }3.6\text{ V}$; $T_{amb} = -40\text{ }^{\circ}\text{C to }+85\text{ }^{\circ}\text{C}$; unless otherwise specified.

Typical case refers to $V_{CC(3V3)} = 3.3\text{ V}$, $V_{CC(I/O)} = 3.3\text{ V}$; $T_{amb} = +25\text{ }^{\circ}\text{C}$; unless otherwise specified.

Symbol	Parameter description	Condition	SRAM mode		Multiplex mode		Unit
			Min	Max	Min	Max	
t_{RP}	RD_N/DS_N/RE_N/OE_N pulse width		30	-	30	-	ns
t_{RC}	RD_N/DS_N/RE_N/OE_N cycle time	host or OTG	49	-	68	-	ns
		peripheral	100	-	100	-	ns
t_{P13}	memory read pre-fetch time		105	-	105	-	ns

Table 161. PIO timing

$V_{CC(3V3)} = 3.0\text{ V to }3.6\text{ V}$; $V_{CC(I/O)} = 1.65\text{ V to }1.95\text{ V}$; $T_{amb} = -40\text{ }^{\circ}\text{C to }+85\text{ }^{\circ}\text{C}$; unless otherwise specified.

Typical case refers to $V_{CC(3V3)} = 3.3\text{ V}$, $V_{CC(I/O)} = 1.8\text{ V}$; $T_{amb} = +25\text{ }^{\circ}\text{C}$; unless otherwise specified.

Symbol	Parameter description	Conditions	SRAM mode		Multiplex mode		Unit
			Min	Max	Min	Max	
t_{CS}	CS_N/CE_N set-up time before WR_N/RW_N/WE_N or RD_N/DS_N/RE_N/OE_N LOW		0	-	0	-	ns
t_{CH}	CS_N/CE_N hold time after WR_N/RW_N/WE_N or RD_N/DS_N/RE_N/OE_N HIGH		0	-	0	-	ns
t_{CP}	CS_N/CE_N pulse width for read		38	-	38	-	ns
			17	-	17	-	ns
$t_{CSADVAL}$	CS_N/CE_N set-up time before address latch		-	-	6	-	ns
t_{ASRW}	address set-up time before WR_N/RW_N/WE_N or RD_N/DS_N/RE_N/OE_N LOW		0	-	-	-	ns
t_{AHRW}	address hold time after WR_N/RW_N/WE_N or RD_N/DS_N/RE_N/OE_N LOW		10	-	-	-	ns
t_{AH}	address hold time after address latch		-	-	0	-	ns
t_{AS}	address set-up time before address latch		-	-	10	-	ns
t_{AP}	address latch pulse width		-	-	17	-	ns
t_{WC}	write cycle time	host or OTG	38	-	68	-	ns
		peripheral	100	-	100	-	ns
t_{WP}	WR_N/RW_N/WE_N pulse width		17	-	17	-	ns
t_{DH}	RD_N/DS_N/RE_N/OE_N HIGH to output Hi-Z		1	10	1	10	ns
	WR_N/RW_N/WE_N HIGH to input Hi-Z		0	-	0	-	ns
t_{DADVH}	data set-up time before data latch		10	-	10	-	ns
t_{OE}	RD_N/DS_N/RE_N/OE_N LOW to data output enable		2	-	2	-	ns
t_{BDS}	ready to WR_N/RW_N/WE_N or RD_N/DS_N/RE_N/OE_N LOW		-	-	5	-	ns

Table 161. PIO timing ...continued

$V_{CC(3V3)} = 3.0\text{ V to }3.6\text{ V}$; $V_{CC(I/O)} = 1.65\text{ V to }1.95\text{ V}$; $T_{amb} = -40\text{ }^{\circ}\text{C to }+85\text{ }^{\circ}\text{C}$; unless otherwise specified.
 Typical case refers to $V_{CC(3V3)} = 3.3\text{ V}$, $V_{CC(I/O)} = 1.8\text{ V}$; $T_{amb} = +25\text{ }^{\circ}\text{C}$; unless otherwise specified.

Symbol	Parameter description	Conditions	SRAM mode		Multiplex mode		Unit
			Min	Max	Min	Max	
t_{RP}	RD_N/DS_N/RE_N/OE_N pulse width		38	-	38	-	ns
t_{RC}	RD_N/DS_N/RE_N/OE_N cycle time	host or OTG	54	-	68	-	ns
		peripheral	100	-	100	-	ns
t_{P13}	memory read pre-fetch time		113	-	113	-	ns

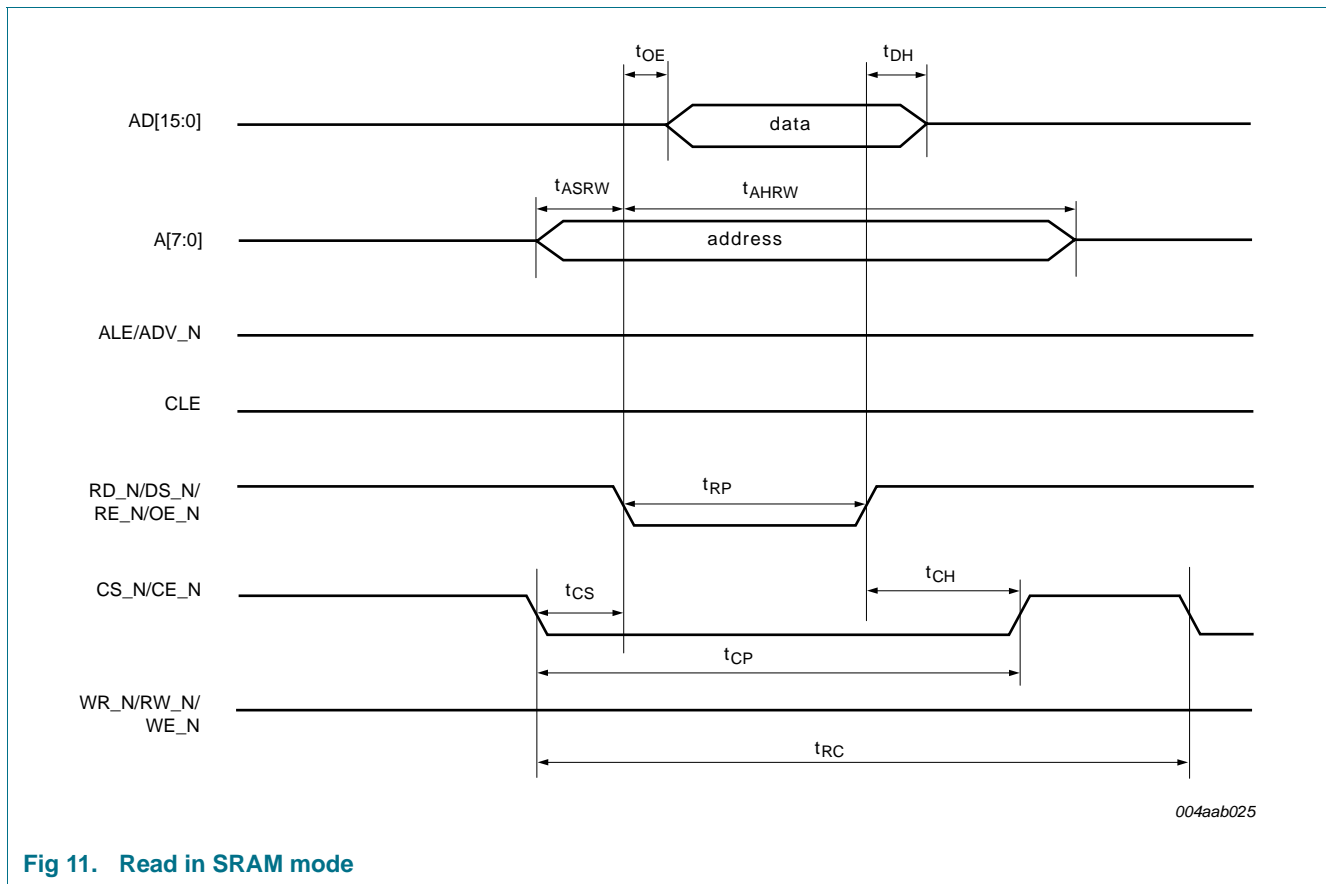

Fig 11. Read in SRAM mode

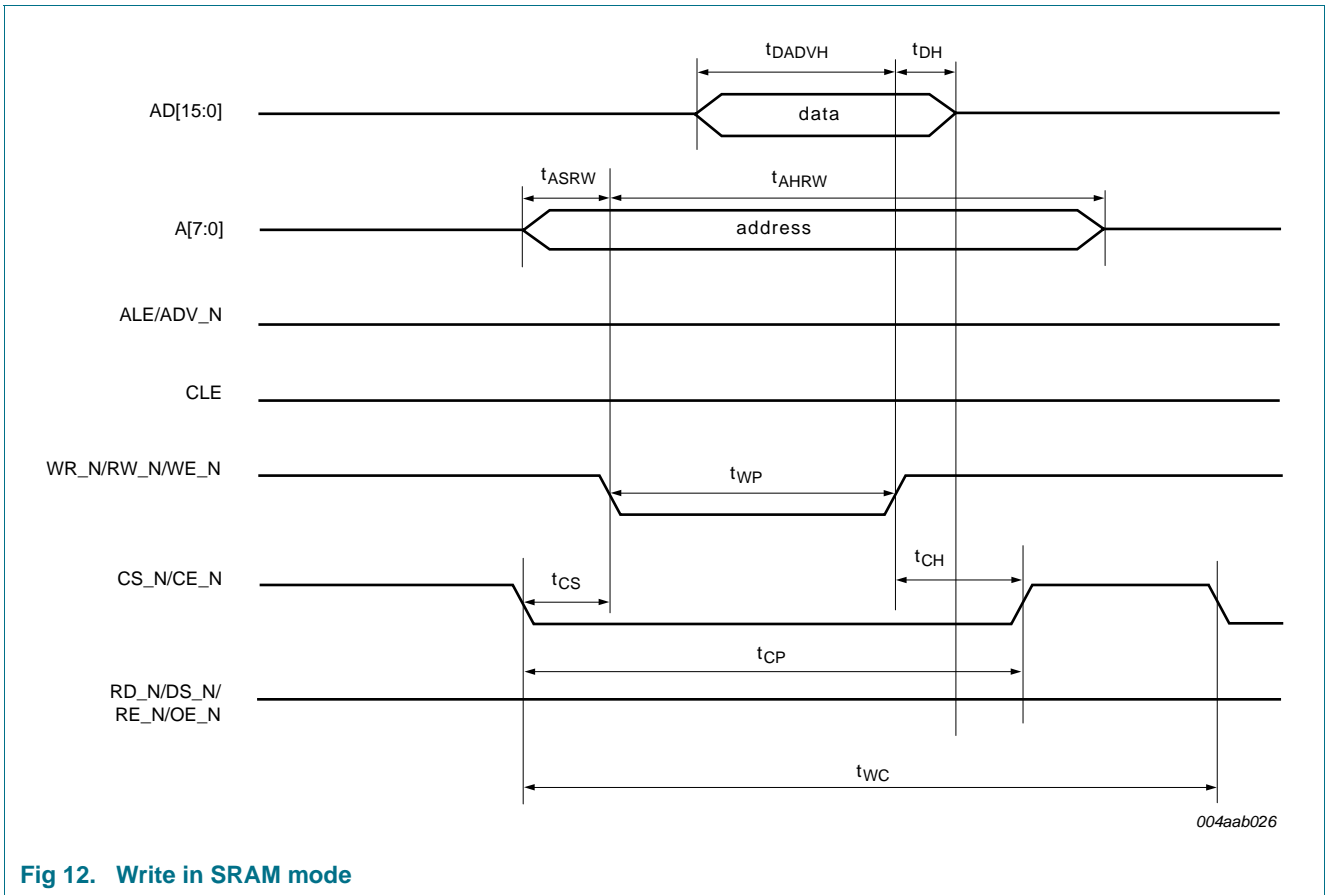
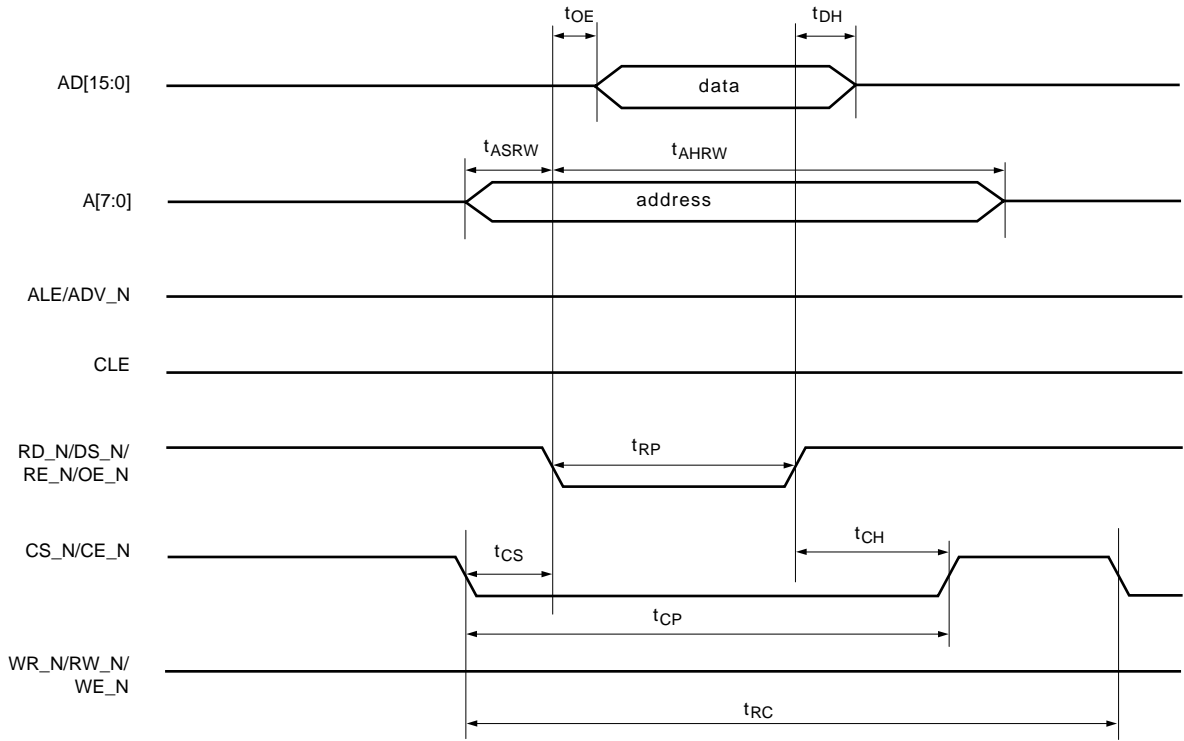

Fig 12. Write in SRAM mode



004ab05

Fig 13. Read in proprietary SRAM mode

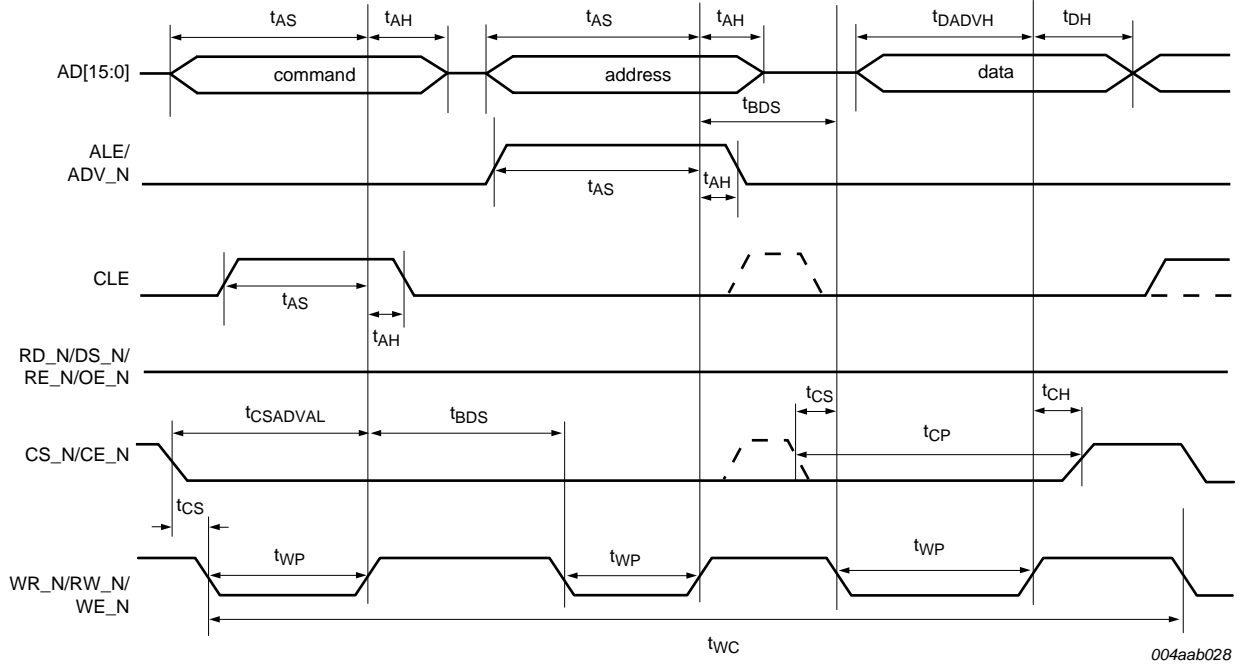

Fig 16. Write in multiplex NAND mode

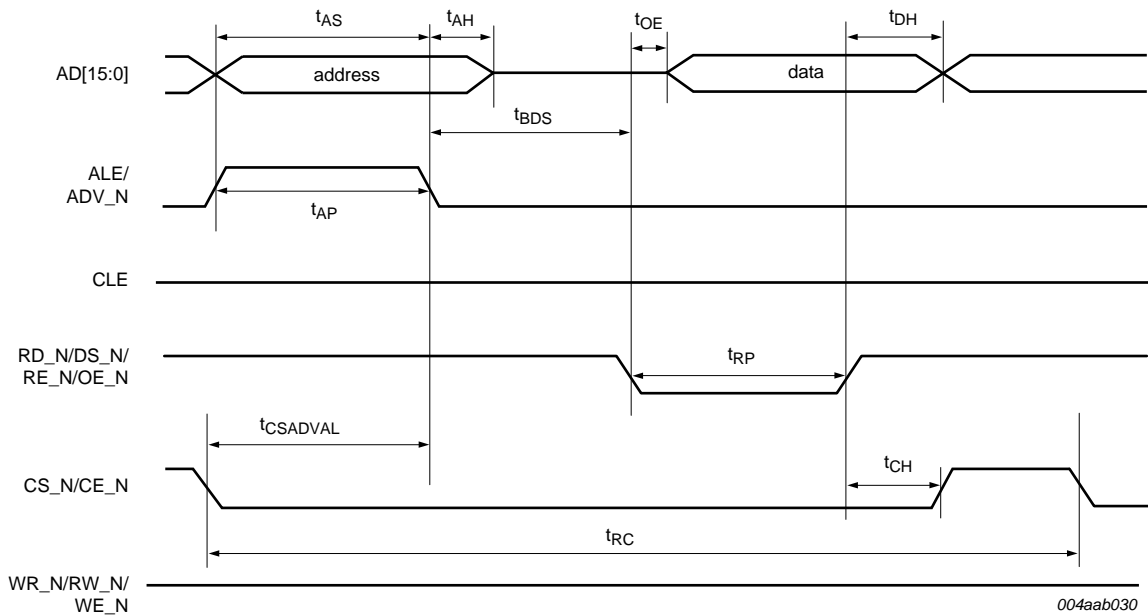

Fig 17. Read in general multiplex mode

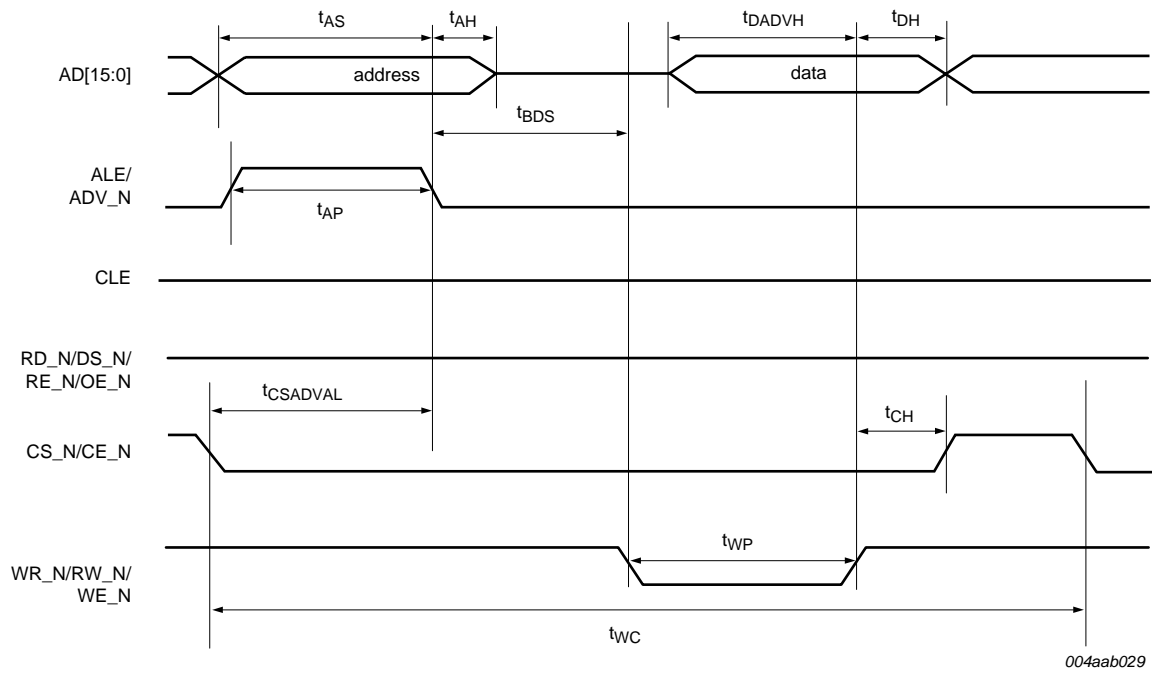

Fig 18. Write in general multiplex mode

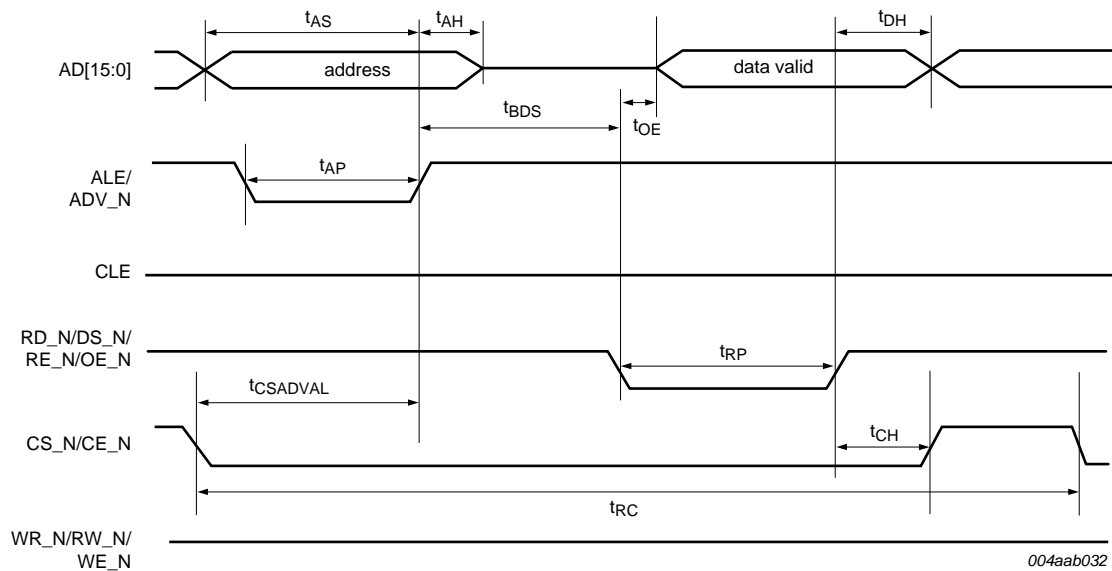
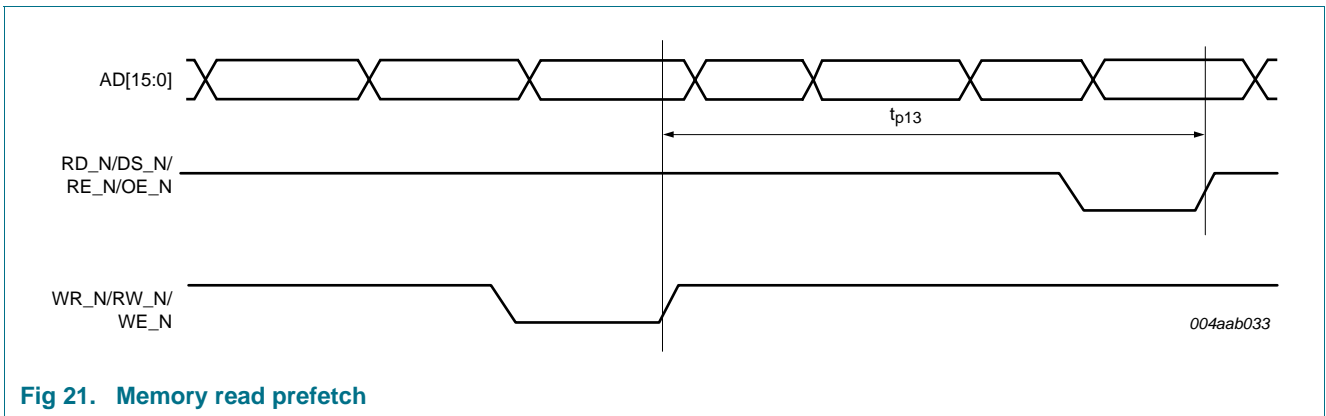
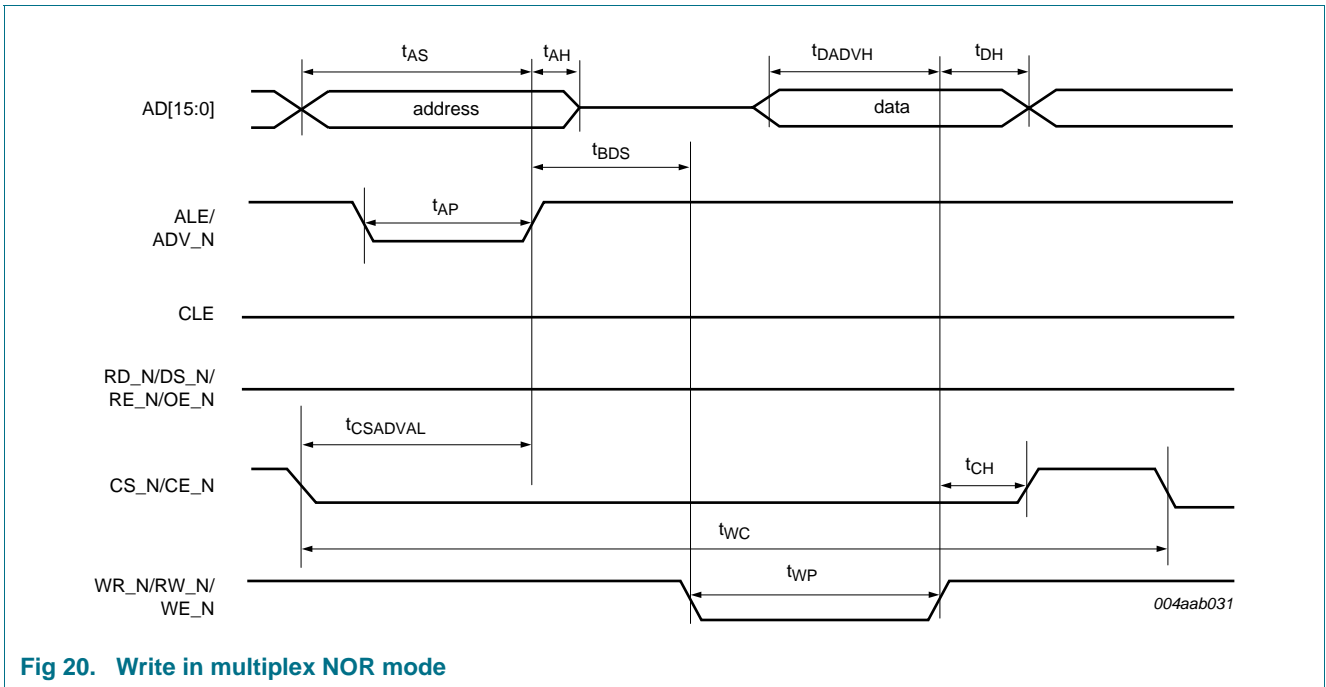

Fig 19. Read in multiplex NOR mode



16. Package outline

VFQFPN64: plastic thermal enhanced very thin quad flat package; no leads; 64 terminals; body 9 x 9 x 1.0 mm

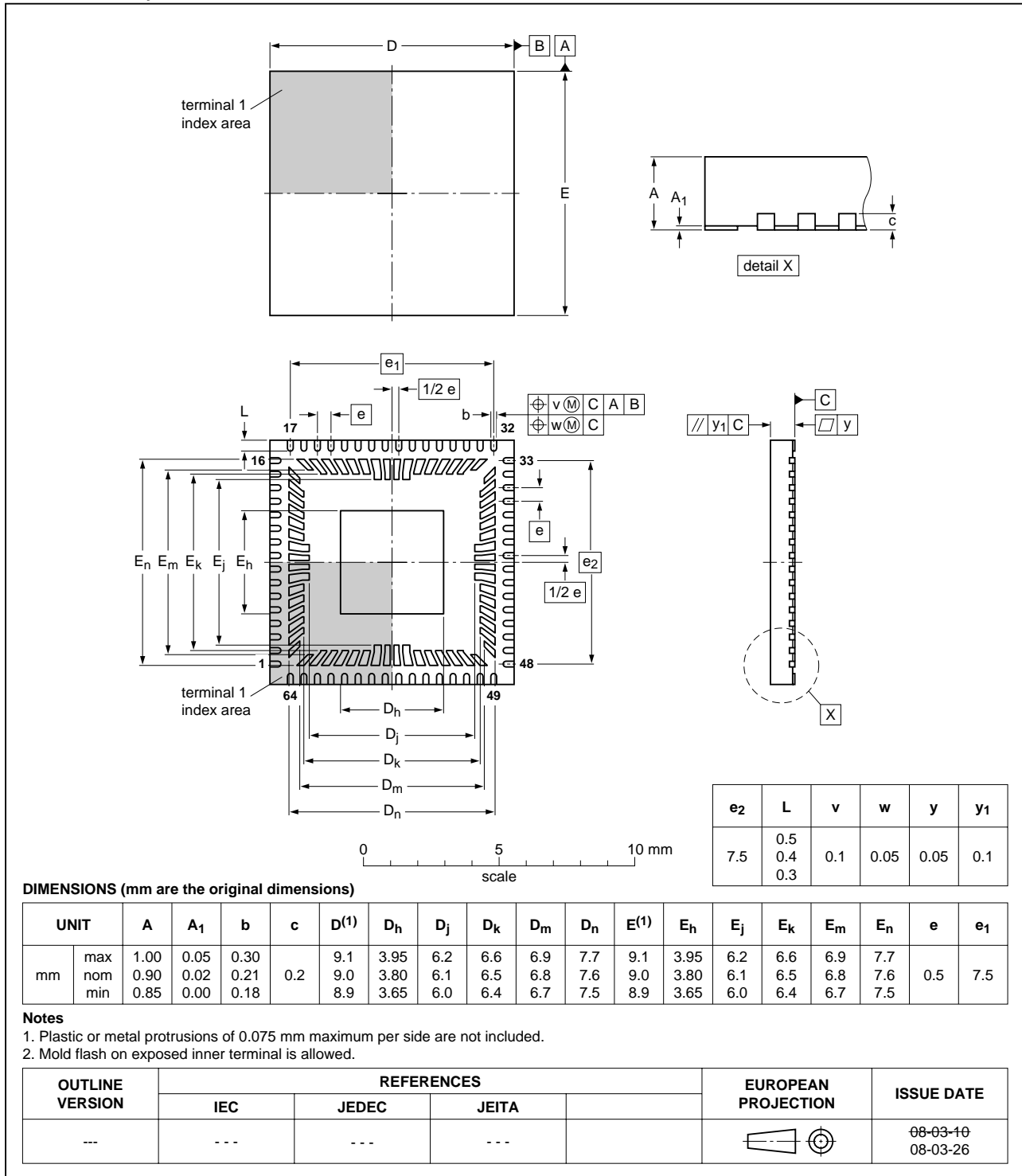

Fig 22. Package outline VFQFPN64

TFBGA64: plastic thin fine-pitch ball grid array package; 64 balls; body 4 x 4 x 0.8 mm

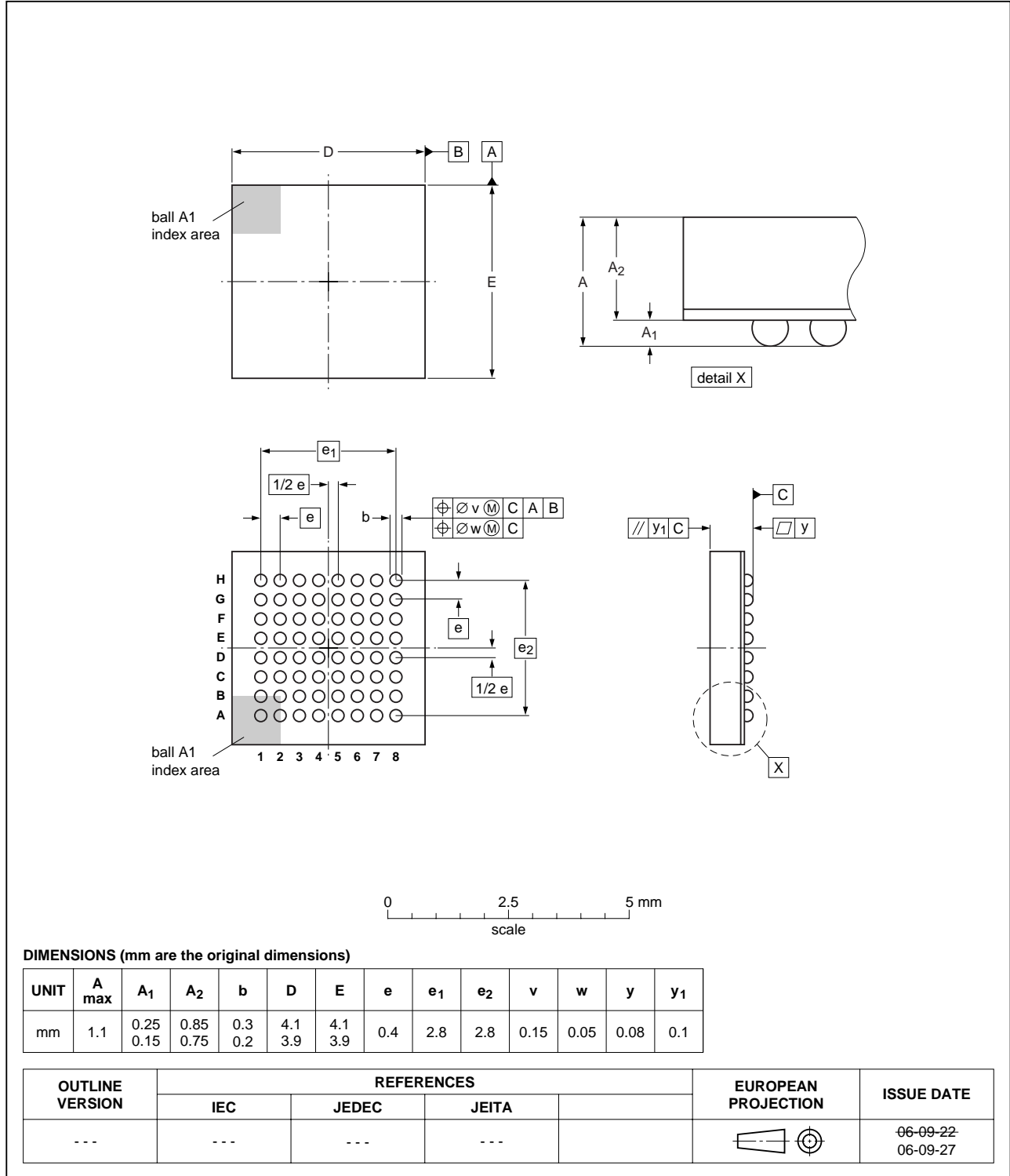

Fig 23. Package outline TFBGA64

17. Abbreviations

Table 162. Abbreviations

Acronym	Description
ACK	Acknowledge
ATL	Asynchronous Transfer List
ATX	Analog USB Transceiver
DMA	Direct Memory Access
EHCI	Enhanced Host Controller Interface
FIFO	First In, First Out
HC	Host Controller
HNP	Host Negotiation Protocol
HS	High-Speed
INT	Interrupt
ISO	Isochronous
NAK	Not Acknowledge
OHCI	Open Host Controller Interface
OTG	On-The-Go
PCB	Printed-Circuit Board
PCI	Peripheral Component Interconnect
PID	Packet Identifier
PIO	Parallel I/O
PLL	Phase-Locked Loop
PTD	Proprietary Transfer Descriptor
SIE	Serial Interface Engine
SOF	Start-Of-Frame
SRP	Session Request Protocol
TT	Transaction Translator
USB	Universal Serial Bus

18. References

- [1] Universal Serial Bus Specification Rev. 2.0
- [2] Enhanced Host Controller Interface Specification for Universal Serial Bus Rev. 1.0
- [3] On-The-Go Supplement to the USB Specification Rev. 1.3

19. Revision history

Table 163. Revision history

Revision	Release date	Data sheet status	Change notice
4	14-Oct-2013	Product data sheet	-
Modifications:	Publication of the features and description on the web product page. No change in the content.		
3	23-Sep-2013	Product data sheet	-
Modifications:	Re-branding to ST. No change in the content.		
2	24-Feb-2011	Product data sheet	-
Modifications:	<ul style="list-style-type: none"> Table 153 "Dynamic characteristics: system clock": updated conditions for f_{clk}. 		
1	18-Mar-2010	Product data sheet	-

20. Tables

Table 1. Ordering information	3	allocation	38
Table 2. Marking codes	3	Table 28. USBSTS - USB Status register (address 90h) bit description	38
Table 3. Pin description	6	Table 29. USBINTR - USB Interrupt register (address 94h) bit allocation	38
Table 4. Bus configuration modes	11	Table 30. USBINTR - USB Interrupt register (address 94h) bit description	39
Table 5. Pinning information of the bus interface	12	Table 31. FRINDEX - Frame Index register (address: 98h) bit allocation	39
Table 6. Register address	15	Table 32. FRINDEX - Frame Index register (address: 98h) bit description	40
Table 7. Memory address	21	Table 33. CONFIGFLAG - Configure Flag register (address 9Ch) bit allocation	40
Table 8. Using the IRQ MASK AND or IRQ MASK OR registers	24	Table 34. CONFIGFLAG - Configure Flag register (address 9Ch) bit description	41
Table 9. Endpoint access and programmability	26	Table 35. PORTSC1 - Port Status and Control 1 register (address A0h) bit allocation	41
Table 10. Power supply	28	Table 36. PORTSC1 - Port Status and Control 1 register (address A0h) bit description	41
Table 11. Overview of OTG controller-specific registers	30	Table 37. ISO PTD Done Map register (address A4h) bit description	42
Table 12. OTG_CTRL - OTG Control register (address set: E4h, clear: E6h) bit allocation	30	Table 38. ISO PTD Skip Map register (address A6h) bit description	42
Table 13. OTG_CTRL - OTG Control register (address set: E4h, clear: E6h) bit description	31	Table 39. ISO PTD Last PTD register (address A8h) bit description	43
Table 14. OTG_INTR_SRC - OTG Interrupt Source register (address E8h) bit allocation	32	Table 40. INT PTD Done Map register (address AAh) bit description	43
Table 15. OTG_INTR_SRC - OTG Interrupt Source register (address E8h) bit description	32	Table 41. INT PTD Skip Map register (address ACh) bit description	43
Table 16. OTG_INTR_L - OTG Interrupt Latch register (address set: ECh, clear: EEh) bit allocation	32	Table 42. INT PTD Last PTD register (address AEh) bit description	44
Table 17. OTG_INTR_L - OTG Interrupt Latch register (address set: ECh, clear: EEh) bit description	33	Table 43. ATL PTD Done Map register (address B0h) bit description	44
Table 18. OTG_INTR_EN_F - OTG Interrupt Enable Fall register (address set: F0h, clear: F2h) bit allocation	33	Table 44. ATL PTD Skip Map register (address B2h) bit description	44
Table 19. OTG_INTR_EN_F - OTG Interrupt Enable Fall register (address set: F0h, clear: F2h) bit description	33	Table 45. ATL PTD Last PTD register (address B4h) bit description	45
Table 20. OTG_INTR_EN_R - OTG Interrupt Enable Rise register (address set: F4h, clear: F6h) bit allocation	34	Table 46. HW Mode Control - Hardware Mode Control register (address B6h) bit allocation	45
Table 21. OTG_INTR_EN_R - OTG Interrupt Enable Rise register (address set: F4h, clear: F6h) bit description	34	Table 47. HW Mode Control - Hardware Mode Control register (address B6h) bit description	45
Table 22. OTG_TMR - OTG Timer register (address low word set: F8h, low word clear: FAh; high word set: FCh, high word clear: FEh) bit allocation	35	Table 48. SW Reset - Software Reset register (address B8h) bit allocation	46
Table 23. OTG_TMR - OTG Timer register (address low word set: F8h, low word clear: FAh; high word set: FCh, high word clear: FEh) bit description	35	Table 49. SW Reset - Software Reset register (address B8h) bit description	47
Table 24. Overview of host controller-specific registers	36	Table 50. HcBufferStatus - Host Controller Buffer Status register (address BAh) bit allocation	47
Table 25. USBCMD - USB Command register (address 8Ch) bit allocation	37	Table 51. HcBufferStatus - Host Controller Buffer Status	
Table 26. USBCMD - USB Command register (address 8Ch) bit description	37		
Table 27. USBSTS - USB Status register (address 90h) bit			

continued >>

register (address BAh) bit description	48		73
Table 52. HcDMAConfiguration - Host Controller Direct Memory Access Configuration register (address BCh) bit allocation	48	Table 83. SE description	75
Table 53. HcDMAConfiguration - Host Controller Direct Memory Access Configuration register (address BCh) bit description	49	Table 84. Start and complete split for isochronous: bit allocation	76
Table 54. ATL Done Timeout register (address: C0h) bit description	49	Table 85. Start and complete split for isochronous: bit description	77
Table 55. Memory register (address C4h) bit allocation .	50	Table 86. Start and complete split for interrupt: bit allocation	80
Table 56. Memory register (address C4h) bit description	50	Table 87. Start and complete split for interrupt: bit description	81
Table 57. Data Port register (address: C6h) bit description .	50	Table 88. Microframe description	83
Table 58. Edge Interrupt Count register (address C8h) bit allocation	50	Table 89. SE description	83
Table 59. Edge Interrupt Count register (address C8h) bit description	51	Table 90. Peripheral controller-specific register overview	84
Table 60. DMA Data Port register (address 60h) bit description	51	Table 91. ADDR - Address register (address 00h) bit allocation	85
Table 61. DMA Start Address register (address CCh) bit description	51	Table 92. ADDR - Address register (address 00h) bit description	85
Table 62. Power Down Control register (address D0h) bit allocation	51	Table 93. MODE - Mode register (address 0Ch) bit allocation	85
Table 63. Power Down Control register (address D0h) bit description	52	Table 94. MODE - Mode register (address 0Ch) bit description	86
Table 64. HcInterrupt - Host Controller Interrupt register (address D4h) bit description	53	Table 95. INTR_CONF - Interrupt Configuration register (address 10h) bit allocation	87
Table 65. HcInterrupt - Host Controller Interrupt register (address D4h) bit description	54	Table 96. INTR_CONF - Interrupt Configuration register (address 10h) bit description	87
Table 66. HcInterruptEnable - Host Controller Interrupt Enable register (address D6h) bit allocation	55	Table 97. Debug mode settings	87
Table 67. HcInterruptEnable - Host Controller Interrupt Enable register (address D6h) bit description	56	Table 98. DcInterruptEnable - Device Controller Interrupt Enable register (address 14h) bit allocation	88
Table 68. ISO IRQ MASK OR register (address D8h) bit description	57	Table 99. DcInterruptEnable - Device Controller Interrupt Enable register (address 14h) bit description	88
Table 69. INT IRQ MASK OR register (address DAh) bit description	57	Table 100. ENDP_INDEX - Endpoint Index register (address 2Ch) bit allocation	90
Table 70. ATL IRQ MASK OR register (address DCh) bit description	57	Table 101. ENDP_INDEX - Endpoint Index register (address 2Ch) bit description	90
Table 71. ISO IRQ MASK AND register (address DEh) bit description	57	Table 102. Addressing of endpoint buffers	90
Table 72. INT IRQ MASK AND register (address E0h) bit description	58	Table 103. CTRL_FUNC- Control Function register (address 28h) bit allocation	90
Table 73. ATL IRQ MASK AND register (address E2h) bit description	58	Table 104. CTRL_FUNC- Control Function register (address 28h) bit description	91
Table 74. High-speed bulk IN and OUT: bit allocation	60	Table 105. DATA_PORT - Data Port register (address 20h) bit description	92
Table 75. High-speed bulk IN and OUT: bit description	61	Table 106. BUFFER_LENGTH - Buffer Length register (address 1Ch) bit description	92
Table 76. High-speed isochronous IN and OUT: bit allocation	64	Table 107. DcBufferStatus - Device Controller Buffer Status register (address 1Eh) bit allocation	93
Table 77. High-speed isochronous IN and OUT: bit description	65	Table 108. DcBufferStatus - Device Controller Buffer Status register (address 1Eh) bit description	93
Table 78. High-speed interrupt IN and OUT: bit allocation	68	Table 109. ENDP_MAXPKTSIZE - Endpoint MaxPacketSize register (address 04h) bit allocation	93
Table 79. High-speed interrupt IN and OUT: bit description	69	Table 110. ENDP_MAXPKTSIZE - Endpoint MaxPacketSize register (address 04h) bit description	94
Table 80. Microframe description	71	Table 111. ENDP_TYPE - Endpoint Type register (address 08h) bit allocation	94
Table 81. Start and complete split for bulk: bit allocation .	72	Table 112. ENDP_TYPE - Endpoint Type register (address 08h) bit description	95
Table 82. Start and complete split for bulk: bit description .	73	Table 113. Control bits for GDMA read/write (opcode = 00h/01h)	96
		Table 114. DMA_CMD - DMA Command register (address	

30h) bit allocation	96	Table 143. TEST_MODE - Test Mode register (address 84h) bit allocation	106
Table 115. DMA_CMD - DMA Command register (address 30h) bit description	96	Table 144. TEST_MODE - Test Mode register (address 84h) bit description	107
Table 116. DMA commands	96	Table 145. Limiting values	108
Table 117. DMA_XFR_CTR - DMA Transfer Counter register (address 34h) bit allocation	97	Table 146. Recommended operating conditions	108
Table 118. DMA_XFR_CTR - DMA Transfer Counter register (address 34h) bit description	98	Table 147. Static characteristics: supply pins	109
Table 119. DcDMAConfiguration - Device Controller Direct Memory Access Configuration register (address 38h) bit allocation	98	Table 148. Static characteristics: digital pins	109
Table 120. DcDMAConfiguration - Device Controller Direct Memory Access Configuration register (address 38h) bit description	98	Table 149. Static characteristics: USB interface block (pins DM1, DM2, DP1, DP2)	109
Table 121. DMA_HW - DMA Hardware register (address 3Ch) bit allocation	99	Table 150. Static characteristics: V _{BUS} comparators	110
Table 122. DMA_HW - DMA Hardware register (address 3Ch) bit description	99	Table 151. Static characteristics: V _{BUS} resistors	111
Table 123. DMA_INTR_REASON - DMA Interrupt Reason register (address 50h) bit allocation	99	Table 152. Static characteristics: ID detection circuit	111
Table 124. DMA_INTR_REASON - DMA Interrupt Reason register (address 50h) bit description	100	Table 153. Dynamic characteristics: system clock	112
Table 125. Internal EOT-functional relation with bit DMA_XFER_OK	100	Table 154. Dynamic characteristics: power-up and reset	112
Table 126. Status of the bits in the DMA Interrupt Reason register	100	Table 155. Dynamic characteristics: digital pins	112
Table 127. DMA_INTR_EN - DMA Interrupt Enable register (address 54h) bit allocation	101	Table 156. Dynamic characteristics: high-speed source electrical	112
Table 128. DMA_INTR_EN - DMA Interrupt Enable register (address 54h) bit description	101	Table 157. Dynamic characteristics: full-speed source electrical	113
Table 129. DMA_ENDP - DMA Endpoint register (address 58h) bit allocation	101	Table 158. Dynamic characteristics: low-speed source electrical	113
Table 130. DMA_ENDP - DMA Endpoint register (address 58h) bit description	102	Table 159. DMA timing	115
Table 131. DMA_BRST_CTR - DMA Burst Counter register (address 64h) bit allocation	102	Table 160. PIO timing	116
Table 132. DMA_BRST_CTR - DMA Burst Counter register (address 64h) bit description	102	Table 161. PIO timing	117
Table 133. DcInterrupt - Device Controller Interrupt register (address 18h) bit allocation	103	Table 162. Abbreviations	127
Table 134. DcInterrupt - Device Controller Interrupt register (address 18h) bit description	103	Table 163. Revision history	128
Table 135. DcChipID - Device Controller Chip Identifier register (address 70h) bit description	104		
Table 136. FRAME_NO - Frame Number register (address 74h) bit allocation	105		
Table 137. FRAME_NO - Frame Number register (address 74h) bit description	105		
Table 138. SCRATCH - Scratch register (address 78h) bit allocation	105		
Table 139. SCRATCH - Scratch register (address 78h) bit description	105		
Table 140. UNLOCK_DEV - Unlock Device register (address 7Ch) bit allocation	106		
Table 141. UNLOCK_DEV - Unlock Device register (address 7Ch) bit description	106		
Table 142. INTR_PULSE_WIDTH - Interrupt Pulse Width register (address 80h) bit description	106		

21. Figures

Fig 1.	Block diagram	4
Fig 2.	Pin configuration TFBGA64	5
Fig 3.	Pin configuration VFQFPN64	6
Fig 4.	Write operation	13
Fig 5.	HNP sequence of events	18
Fig 6.	Internal hub	20
Fig 7.	Memory segmentation and access block diagram	22
Fig 8.	Power-up and reset sequence	29
Fig 9.	USB source differential data-to-EOP transition skew and EOP width	114
Fig 10.	DMA read and write	115
Fig 11.	Read in SRAM mode	118
Fig 12.	Write in SRAM mode	119
Fig 13.	Read in proprietary SRAM mode	120
Fig 14.	Write in proprietary SRAM mode	121
Fig 15.	Read in multiplex NAND mode	121
Fig 16.	Write in multiplex NAND mode	122
Fig 17.	Read in general multiplex mode	122
Fig 18.	Write in general multiplex mode	123
Fig 19.	Read in multiplex NOR mode	123
Fig 20.	Write in multiplex NOR mode	124
Fig 21.	Memory read prefetch	124
Fig 22.	Package outline VFQFPN64	125
Fig 23.	Package outline TFBGA64	126

[continued >>](#)

22. Contents

1	General description	1	8.12.3	Power-up and reset sequence	29
2	Features	1	8.12.4	ATX reference voltage	29
3	Applications	2	9	OTG controller-specific registers	30
3.1	Host or peripheral roles	2	9.1	OTG control register	30
4	Ordering information	3	9.1.1	OTG Control register	30
5	Marking	3	9.2	OTG interrupt registers	31
6	Block diagram	4	9.2.1	OTG Interrupt Source register	31
7	Pinning information	5	9.2.2	OTG Interrupt Latch register	32
7.1	Pinning	5	9.2.3	OTG Interrupt Enable Fall register	33
7.2	Pin description	6	9.2.4	OTG Interrupt Enable Rise register	34
8	Functional description	11	9.3	OTG Timer register	35
8.1	CPU bus interface	11	9.3.1	OTG Timer register	35
8.2	Interface mode lock	12	10	Host controller-specific registers	36
8.3	SRAM bus interface mode	12	10.1	EHCI operational registers	37
8.4	NAND bus interface mode	13	10.1.1	USBCMD register	37
8.5	NOR bus interface mode	13	10.1.2	USBSTS register	37
8.6	General multiplex bus interface mode	14	10.1.3	USBINTR register	38
8.7	DMA controller	14	10.1.4	FRINDEX register	39
8.8	On-The-Go (OTG) controller	16	10.1.5	CONFIGFLAG register	40
8.8.1	Introduction	16	10.1.6	PORTSC1 register	41
8.8.2	Dual-role device	16	10.1.7	ISO PTD Done Map register	42
8.8.3	Session Request Protocol (SRP)	17	10.1.8	ISO PTD Skip Map register	42
8.8.3.1	B-device initiating SRP	17	10.1.9	ISO PTD Last PTD register	43
8.8.3.2	A-device responding to SRP	17	10.1.10	INT PTD Done Map register	43
8.8.4	Host Negotiation Protocol (HNP)	17	10.1.11	INT PTD Skip Map register	43
8.8.4.1	Sequence of HNP events	18	10.1.12	INT PTD Last PTD register	43
8.8.5	Power saving in the idle state and during wake-up 19	19	10.1.13	ATL PTD Done Map register	44
8.9	USB host controller	19	10.1.14	ATL PTD Skip Map register	44
8.9.1	ISP1763A USB host controller and hub internal architecture	19	10.1.15	ATL PTD Last PTD register	44
8.9.2	Host controller buffer memory block	20	10.2	Configuration registers	45
8.9.2.1	General considerations	20	10.2.1	HW Mode Control register	45
8.9.2.2	Structure of the host controller memory	20	10.2.2	SW Reset register	46
8.9.3	Interrupts	22	10.2.3	HcBufferStatus register	47
8.10	USB peripheral controller	24	10.2.4	HcDMAConfiguration register	48
8.10.1	Introduction	24	10.2.5	ATL Done Timeout register	49
8.10.2	Peripheral controller data transfer operation	25	10.2.6	Memory register	49
8.10.2.1	IN data transfer	25	10.2.7	Data Port register	50
8.10.2.2	OUT data transfer	25	10.2.8	Edge Interrupt Count register	50
8.10.3	Endpoint description	25	10.2.9	DMA Data Port register	51
8.10.4	Peripheral controller suspend	26	10.2.10	DMA Start Address register	51
8.10.5	Peripheral controller resume	27	10.2.11	Power Down Control register	51
8.10.6	Remote wake-up	27	10.3	Interrupt registers	53
8.11	Phase-Locked Loop (PLL) clock multiplier	27	10.3.1	HcInterrupt register	53
8.12	Power management	27	10.3.2	HcInterruptEnable register	55
8.12.1	Power supply	27	10.3.3	ISO IRQ MASK OR register	57
8.12.2	Power modes	28	10.3.4	INT IRQ MASK OR register	57
8.12.2.1	Operation mode	28	10.3.5	ATL IRQ MASK OR register	57
8.12.2.2	Suspend mode	28	10.3.6	ISO IRQ MASK AND register	57
8.12.2.3	Deep sleep mode	28	10.3.7	INT IRQ MASK AND register	58
8.12.2.4	Power-down mode	28	10.3.8	ATL IRQ MASK AND register	58
8.12.2.5	ISP1763A wake up	28	10.4	Proprietary Transfer Descriptor (PTD)	58
8.12.2.6	Isolation mode	29	10.4.1	High-speed bulk IN and OUT	60
			10.4.2	High-speed isochronous IN and OUT	64
			10.4.3	High-speed interrupt IN and OUT	68
			10.4.4	Start and complete split for bulk	72

10.4.5	Start and complete split for isochronous.	76
10.4.6	Start and complete split for interrupt.	80
11	Peripheral controller-specific registers.	84
11.1	Register access	84
11.2	Initialization registers	85
11.2.1	Address register	85
11.2.2	Mode register	85
11.2.3	Interrupt Configuration register.	86
11.2.4	DcInterruptEnable register	87
11.3	Data flow registers	89
11.3.1	Endpoint Index register.	89
11.3.2	Control Function register	90
11.3.3	Data Port register	91
11.3.4	Buffer Length register	92
11.3.5	DcBufferStatus register.	93
11.3.6	Endpoint MaxPacketSize register.	93
11.3.7	Endpoint Type register	94
11.4	DMA registers.	95
11.4.1	DMA Command register	96
11.4.2	DMA Transfer Counter register.	97
11.4.3	DcDMAConfiguration register.	98
11.4.4	DMA Hardware register	99
11.4.5	DMA Interrupt Reason register.	99
11.4.6	DMA Interrupt Enable register	100
11.4.7	DMA Endpoint register	101
11.4.8	DMA Burst Counter register	102
11.5	General registers	102
11.5.1	DcInterrupt register.	102
11.5.2	Chip ID register.	104
11.5.3	Frame Number register.	104
11.5.4	Scratch register	105
11.5.5	Unlock Device register	105
11.5.6	Interrupt Pulse Width register.	106
11.5.7	Test Mode register	106
12	Limiting values.	108
13	Recommended operating conditions.	108
14	Static characteristics.	109
15	Dynamic characteristics	112
15.1	Timing.	115
15.1.1	DMA	115
15.1.2	PIO	116
16	Package outline	125
17	Abbreviations.	127
18	References	127
19	Revision history.	128
20	Tables	129
21	Figures	132
22	Contents	133

Please Read Carefully:

Information in this document is provided solely in connection with ST products. STMicroelectronics NV and its subsidiaries ("ST") reserve the right to make changes, corrections, modifications or improvements, to this document, and the products and services described herein at any time, without notice.

All ST products are sold pursuant to ST's terms and conditions of sale.

Purchasers are solely responsible for the choice, selection and use of the ST products and services described herein, and ST assumes no liability whatsoever relating to the choice, selection or use of the ST products and services described herein.

No license, express or implied, by estoppel or otherwise, to any intellectual property rights is granted under this document. If any part of this document refers to any third party products or services it shall not be deemed a license grant by ST for the use of such third party products or services, or any intellectual property contained therein or considered as a warranty covering the use in any manner whatsoever of such third party products or services or any intellectual property contained therein.

UNLESS OTHERWISE SET FORTH IN ST'S TERMS AND CONDITIONS OF SALE ST DISCLAIMS ANY EXPRESS OR IMPLIED WARRANTY WITH RESPECT TO THE USE AND/OR SALE OF ST PRODUCTS INCLUDING WITHOUT LIMITATION IMPLIED WARRANTIES OF MERCHANTABILITY, FITNESS FOR A PARTICULAR PURPOSE (AND THEIR EQUIVALENTS UNDER THE LAWS OF ANY JURISDICTION), OR INFRINGEMENT OF ANY PATENT, COPYRIGHT OR OTHER INTELLECTUAL PROPERTY RIGHT.

ST PRODUCTS ARE NOT DESIGNED OR AUTHORIZED FOR USE IN: (A) SAFETY CRITICAL APPLICATIONS SUCH AS LIFE SUPPORTING, ACTIVE IMPLANTED DEVICES OR SYSTEMS WITH PRODUCT FUNCTIONAL SAFETY REQUIREMENTS; (B) AERONAUTIC APPLICATIONS; (C) AUTOMOTIVE APPLICATIONS OR ENVIRONMENTS, AND/OR (D) AEROSPACE APPLICATIONS OR ENVIRONMENTS. WHERE ST PRODUCTS ARE NOT DESIGNED FOR SUCH USE, THE PURCHASER SHALL USE PRODUCTS AT PURCHASER'S SOLE RISK, EVEN IF ST HAS BEEN INFORMED IN WRITING OF SUCH USAGE, UNLESS A PRODUCT IS EXPRESSLY DESIGNATED BY ST AS BEING INTENDED FOR "AUTOMOTIVE, AUTOMOTIVE SAFETY OR MEDICAL" INDUSTRY DOMAINS ACCORDING TO ST PRODUCT DESIGN SPECIFICATIONS. PRODUCTS FORMALLY ESCC, QML OR JAN QUALIFIED ARE DEEMED SUITABLE FOR USE IN AEROSPACE BY THE CORRESPONDING GOVERNMENTAL AGENCY.

Resale of ST products with provisions different from the statements and/or technical features set forth in this document shall immediately void any warranty granted by ST for the ST product or service described herein and shall not create or extend in any manner whatsoever, any liability of ST.

ST and the ST logo are trademarks or registered trademarks of ST in various countries.
Information in this document supersedes and replaces all information previously supplied.

The ST logo is a registered trademark of STMicroelectronics. All other names are the property of their respective owners.

© 2013 STMicroelectronics - All rights reserved

STMicroelectronics group of companies

Australia - Belgium - Brazil - Canada - China - Czech Republic - Finland - France - Germany - Hong Kong - India - Israel - Italy - Japan - Malaysia - Malta - Morocco - Philippines - Singapore - Spain - Sweden - Switzerland - United Kingdom - United States of America

www.st.com