

SI-8000W Series Surface-Mount, Separate Excitation Step-down Switching Mode

■Features

- Surface-mount package (SOP8)
- Output current: 0.6A
- High efficiency: 75 to 80%
- Requires only 4 discrete components
- Internally-adjusted phase correction and output voltage adjustment performed internally
- Built-in reference oscillator (60kHz)
- Built-in overcurrent and thermal protection circuits

■Absolute Maximum Ratings

Parameter	Symbol	Ratings	Unit
DC Input Voltage	V_{IN}	35	V
Power Dissipation	P_D	1	W
Junction Temperature	T_j	-30 to +125	°C
Storage Temperature	T_{stg}	-40 to +125	°C
Thermal Resistance (Junction to 7-Pin Lead)	θ_{j-L}	22	°C/W
Thermal Resistance (Junction to Ambient Air) ^{*1}	θ_{j-a}	100	°C/W

*1: Glass-epoxy board of 40 × 40mm (copper laminate area 4.3%)

■Applications

- Power supplies for telecommunication equipment
- Onboard local power supplies

■Recommended Operating Conditions

Parameter	Symbol	Ratings		Unit
		SI-8033W	SI-8050W	
DC Input Voltage Range	V_{IN}	5.3 to 28	7 to 33	V
Output Current Range	I_O	0 to 0.6		A
Operating Junction Temperature Range	T_{jop}	-30 to +125		°C

■Electrical Characteristics

($T_a=25^\circ\text{C}$)

Parameter	Symbol	Ratings						Unit
		SI-8033W			SI-8050W			
		min.	typ.	max.	min.	typ.	max.	
Output Voltage	V_O	3.17	3.30	3.43	4.80	5.00	5.20	V
	Conditions	$V_{IN}=15\text{V}, I_O=0.3\text{A}$			$V_{IN}=20\text{V}, I_O=0.3\text{A}$			
Efficiency	η	75			80			%
	Conditions	$V_{IN}=15\text{V}, I_O=0.3\text{A}$			$V_{IN}=20\text{V}, I_O=0.3\text{A}$			
Oscillation Frequency	f	60			60			kHz
	Conditions	$V_{IN}=15\text{V}, I_O=0.3\text{A}$			$V_{IN}=20\text{V}, I_O=0.3\text{A}$			
Line Regulation	ΔV_{OLINE}	60			80			mV
	Conditions	$V_{IN}=8\text{ to }28\text{V}, I_O=0.3\text{A}$			$V_{IN}=10\text{ to }30\text{V}, I_O=0.3\text{A}$			
Load Regulation	ΔV_{OLOAD}	20			30			mV
	Conditions	$V_{IN}=15\text{V}, I_O=0.1\text{ to }0.4\text{A}$			$V_{IN}=20\text{V}, I_O=0.1\text{ to }0.4\text{A}$			
Temperature Coefficient of Output Voltage	$\Delta V_O/\Delta T_a$	± 0.5			± 0.5			mV/°C
Ripple Rejection	R_{REJ}	45			45			dB
	Conditions	$f=100\text{ to }120\text{Hz}$			$f=100\text{ to }120\text{Hz}$			
Overcurrent Protection Starting Current	I_{S1}	0.61			0.61			A
	Conditions	$V_{IN}=15\text{V}$			$V_{IN}=20\text{V}$			

External Dimensions (SOP8)

(Unit : mm)

Block Diagram

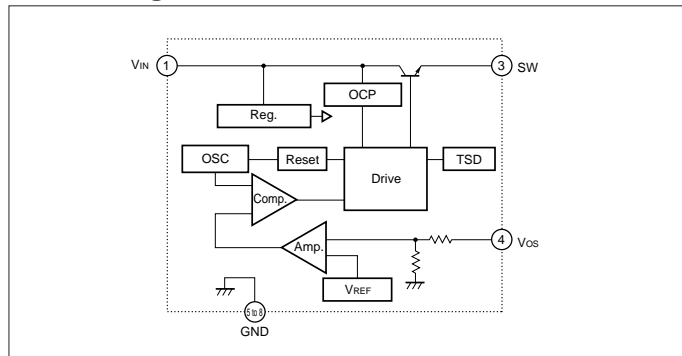

Typical Connection Diagram

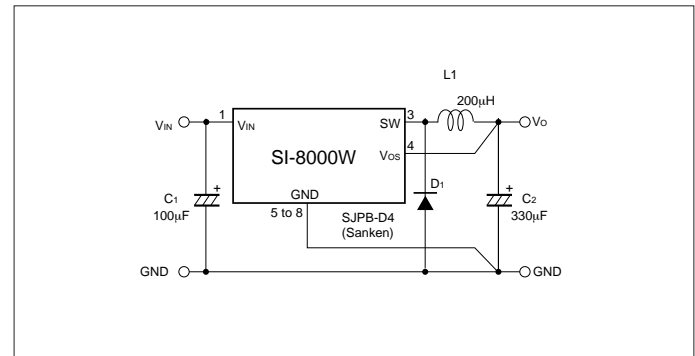

Reference Data

