

Product Specification

OC-48 SR/STM I-16 RoHS Compliant Pluggable SFP Transceiver

FTLF1321P1xTL

PRODUCT FEATURES

- Up to 2.67Gb/s bi-directional data links
- Hot-pluggable SFP footprint
- Built-in digital diagnostic functions
- Uncooled Fabry-Perot 1310nm laser transmitter
- Duplex LC connector
- RoHS compliant and lead-free
- Metal enclosure, for lower EMI
- Single 3.3V power supply
- Low power dissipation <700mW typical
- Extended operating temperature range: -40°C to 85°C



APPLICATIONS

- SONET OC-48 SR / SDH STM I-16
- SONET OC-12 SR / SDH STM I-4
- SONET OC-3 SR / SDH STM I-1
- Gigabit Ethernet / Fibre Channel

Finisar's FTLF1321P1xTL Small Form Factor Pluggable (SFP) transceivers are compatible with the Small Form Factor Pluggable Multi-Sourcing Agreement (MSA)¹. They comply with SONET OC-48 SR (SDH STM I-16) standards², Gigabit Ethernet as specified in IEEE Std 802.3³ and Fibre Channel FC-PI 13.0⁴. They are compatible with SONET OC-12 and SONET OC-3 standards². Digital diagnostics functions are available via the 2-wire serial bus specified in the SFP MSA. They are RoHS compliant and lead-free per Directive 2002/95/EC⁵ and Finisar Application Note AN-2038.

PRODUCT SELECTION

FTLF1321P1xTL

x	W	Wide Extraction Bail
	B	Narrow Extraction Bail

I. Pin Descriptions

Pin	Symbol	Name/Description	Ref.
1	V _{EET}	Transmitter Ground (Common with Receiver Ground)	1
2	T _{FAULT}	Transmitter Fault. Not supported.	
3	T _{DIS}	Transmitter Disable. Laser output disabled on high or open.	2
4	MOD_DEF(2)	Module Definition 2. Data line for Serial ID.	3
5	MOD_DEF(1)	Module Definition 1. Clock line for Serial ID.	3
6	MOD_DEF(0)	Module Definition 0. Grounded within the module.	3
7	Rate Select	No connection required	4
8	LOS	Loss of Signal indication. Logic 0 indicates normal operation.	5
9	V _{EER}	Receiver Ground (Common with Transmitter Ground)	1
10	V _{EER}	Receiver Ground (Common with Transmitter Ground)	1
11	V _{EER}	Receiver Ground (Common with Transmitter Ground)	1
12	RD-	Receiver Inverted DATA out. AC Coupled.	
13	RD+	Receiver Non-inverted DATA out. AC Coupled.	
14	V _{EER}	Receiver Ground (Common with Transmitter Ground)	1
15	V _{CCR}	Receiver Power Supply	
16	V _{CCT}	Transmitter Power Supply	
17	V _{EET}	Transmitter Ground (Common with Receiver Ground)	1
18	TD+	Transmitter Non-Inverted DATA in. AC Coupled.	
19	TD-	Transmitter Inverted DATA in. AC Coupled.	
20	V _{EET}	Transmitter Ground (Common with Receiver Ground)	1

Notes:

1. Circuit ground is internally isolated from chassis ground.
2. Laser output disabled on T_{DIS} > 2.0V or open, enabled on T_{DIS} < 0.8V.
3. Should be pulled up with 4.7k - 10kohms on host board to a voltage between 2.0V and 3.6V. MOD_DEF(0) pulls line low to indicate module is plugged in.
4. Finisar FTLFxx21xxxxx transceivers operate between OC-3 and OC-48, 1x and 2x Fibre Channel, and Gigabit Ethernet data rates and respective protocols without active control. Finisar FTLFxx19xxxxx transceivers operate at 1x and 2x Fibre Channel, and Gigabit Ethernet data rates and respective protocols without active control.
5. LOS is open collector output. Should be pulled up with 4.7k - 10kohms on host board to a voltage between 2.0V and 3.6V. Logic 0 indicates normal operation; logic 1 indicates loss of signal.

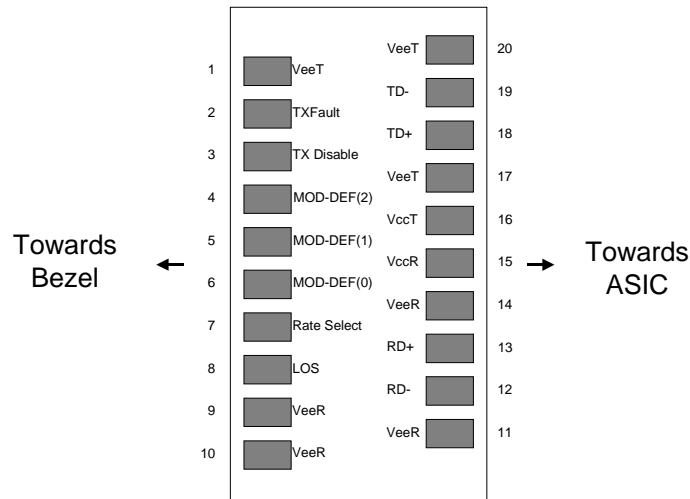

Pinout of Connector Block on Host Board

II. Absolute Maximum Ratings

Parameter	Symbol	Min	Typ	Max	Unit	Ref.
Maximum Supply Voltage	V _{CC}	-0.5		4.5	V	
Storage Temperature	T _S	-40		100	°C	
Case Operating Temperature	T _{OP}	-40		85	°C	
Relative Humidity	RH	0		85	%	1

III. Electrical Characteristics (T_{OP} = -40 to 85 °C, V_{CC} = 3.00 to 3.60 Volts)

Parameter	Symbol	Min	Typ	Max	Unit	Ref.
Supply Voltage	V _{CC}	3.00		3.60	V	
Supply Current	I _{CC}		165	300	mA	
Transmitter						
Input differential impedance	R _{in}		100		Ω	2
Single ended data input swing	V _{in,pp}	250		1200	mV	
Transmit Disable Voltage	V _D	V _{CC} – 1.3		V _{CC}	V	
Transmit Enable Voltage	V _{EN}	V _{EE}		V _{EE} + 0.8	V	3
Transmit Disable Assert Time				10	μs	
Receiver						
Single ended data output swing	V _{out,pp}	300	400	800	mV	4
Data output rise time	t _r		100	175	ps	5
Data output fall time	t _f		100	175	ps	5
LOS Fault	V _{LOS fault}	V _{CC} – 0.5		V _{CC} _{HOST}	V	6
LOS Normal	V _{LOS norm}	V _{EE}		V _{EE} +0.5	V	6
Power Supply Rejection	PSR	100			mV _{pp}	7
Total Generated Receiver Jitter (peak to peak)	J _{RXP-P}			0.07	UI	
Total Generated Receiver Jitter (rms)	J _{RXRms}			0.007	UI	

Notes:

1. Non condensing.
2. AC coupled.
3. Or open circuit.
4. Into 100 ohm differential termination.
5. 20 – 80 %
6. Loss Of Signal is LVTTTL. Logic 0 indicates normal operation; logic 1 indicates no signal detected.
7. All transceiver specifications are compliant with a power supply sinusoidal modulation of 20 Hz to 1.5 MHz up to specified value applied through the power supply filtering network shown on page 23 of the Small Form-factor Pluggable (SFP) Transceiver MultiSource Agreement (MSA), September 14, 2000.

IV. Optical Characteristics ($T_{OP} = -40$ to 85 °C, $V_{CC} = 3.00$ to 3.60 Volts)

Parameter	Symbol	Min	Typ	Max	Unit	Ref.
Transmitter						
Output Opt. Pwr: 9/125 SMF	P_{OUT}	-9.5		-3	dBm	1
Optical Wavelength	λ	1270		1360	nm	2
Spectral Width	σ			3	nm	2
Optical Extinction Ratio	ER	9			dB	
Optical Rise/Fall Time	t_r/ t_f			160	ps	3
Relative Intensity Noise	RIN			-120	dB/Hz	
Total Generated Transmitter Jitter (peak to peak)	J_{TXP-p}			0.07	UI	
Total Generated Transmitter Jitter (rms)	J_{TXrms}			0.007	UI	
Receiver						
Average Rx Sensitivity @ 2.67Gb/s	R_{SENS1}	0		-18	dBm	4
Average Rx Sensitivity @ OC-48	R_{SENS1}	0		-18	dBm	4
Average Rx Sensitivity @ 2X Fibre Channel	R_{SENS2}	0		-19	dBm	5
Average Rx Sensitivity @ Gigabit Ethernet	R_{SENS3}	0		-19	dBm	5
Average Rx Sensitivity @ OC-12	R_{SENS4}	0		-19	dBm	6
Average Rx Sensitivity @ OC-3	R_{SENS5}	-8		-19	dBm	6
Optical Center Wavelength	λ_C	1270		1600	nm	
LOS De-Assert	LOS_D		-23	-19	dBm	
LOS Assert	LOS_A	-30	-25		dBm	
LOS Hysteresis		0.5			dB	

Notes:

1. Class 1 Laser Safety per FDA/CDRH and EN (IEC) 60825 regulations.
2. Also specified to meet curves in FC-PI 13.0 Figures 18 and 19, which allow trade-off between wavelength, spectral width and OMA.
3. Unfiltered, 20-80%.
4. With worst-case extinction ratio. Measured with a PRBS $2^{31}-1$ test pattern interspersed with 72 consecutive ones and 72 consecutive zeros.
5. With worst-case extinction ratio. Measured with a PRBS 2^7-1 test pattern.
6. With worst-case extinction ratio. Measured with a PRBS $2^{23}-1$ test pattern.

V. General Specifications

Parameter	Symbol	Min	Typ	Max	Units	Ref.
Data Rate	BR	155		2667	Mb/sec	1
Bit Error Rate	BER			10^{-12}		2
Max. Supported Link Length on 9/125 μ m SMF @ OC-48	L _{MAX1}		5		km	4
Max. Supported Link Length on 9/125 μ m SMF @ 2X Fibre Channel	L _{MAX2}		10		km	3
Max. Supported Link Length on 9/125 μ m SMF @ Gigabit Ethernet	L _{MAX3}		10		km	3
Max. Supported Link Length on 9/125 μ m SMF @ OC-12	L _{MAX4}		10		km	4
Max. Supported Link Length on 9/125 μ m SMF @ OC-3	L _{MAX5}		10		km	4

Notes:

- SONET OC-48 SR/SDH STM I-16, Gigabit Ethernet and 1x/2x Fibre Channel compliant. Compatible with SONET OC-12 and OC-3. Supports FEC at 2.67 Gb/s.
- Tested with a PRBS $2^{31}-1$ test pattern interspersed with 72 consecutive ones and 72 consecutive zeros.
- Dispersion limited per FC-PI Rev. 13
- Attenuation of 0.55 dB/km is used for the link length calculations (per GR-253 CORE). Distances are indicative only. Please refer to the Optical Specifications in Table IV to calculate a more accurate link budget based on specific conditions in your application.

VI. Environmental Specifications

Finisar 1310nm SFP transceivers have an extended operating temperature range from -40°C to $+85^{\circ}\text{C}$ case temperature.

Parameter	Symbol	Min	Typ	Max	Units	Ref.
Case Operating Temperature	T _{op}	-40		85	$^{\circ}\text{C}$	
Storage Temperature	T _{sto}	-40		100	$^{\circ}\text{C}$	

VII. Regulatory Compliance

Finisar transceivers are Class 1 Laser Products and comply with US FDA regulations. These products are certified by TÜV and CSA to meet the Class 1 eye safety requirements of EN (IEC) 60825 and the electrical safety requirements of EN (IEC) 60950. Copies of certificates are available at Finisar Corporation upon request.

VIII. Digital Diagnostic Functions

Finisar FTLF1321P1xTL SFP transceivers support the 2-wire serial communication protocol as defined in the SFP MSA¹. It is very closely related to the E²PROM defined in the GBIC standard, with the same electrical specifications.

The standard SFP serial ID provides access to identification information that describes the transceiver's capabilities, standard interfaces, manufacturer, and other information.

Additionally, Finisar SFP transceivers provide a unique enhanced digital diagnostic monitoring interface, which allows real-time access to device operating parameters such as transceiver temperature, laser bias current, transmitted optical power, received optical power and transceiver supply voltage. It also defines a sophisticated system of alarm and warning flags, which alerts end-users when particular operating parameters are outside of a factory-set normal range.

The SFP MSA defines a 256-byte memory map in E²PROM that is accessible over a 2-wire serial interface at the 8 bit address 1010000X (A0h). The digital diagnostic monitoring interface makes use of the 8 bit address 1010001X (A2h), so the originally defined serial ID memory map remains unchanged. The interface is identical to, and is thus fully backward compatible with both the GBIC Specification and the SFP Multi Source Agreement. The complete interface is described in Finisar Application Note AN-2030: "Digital Diagnostics Monitoring Interface for SFP Optical Transceivers".

The operating and diagnostics information is monitored and reported by a Digital Diagnostics Transceiver Controller (DDTC) inside the transceiver, which is accessed through a 2-wire serial interface. When the serial protocol is activated, the serial clock signal (SCL, Mod Def 1) is generated by the host. The positive edge clocks data into the SFP transceiver into those segments of the E²PROM that are not write-protected. The negative edge clocks data from the SFP transceiver. The serial data signal (SDA, Mod Def 2) is bi-directional for serial data transfer. The host uses SDA in conjunction with SCL to mark the start and end of serial protocol activation. The memories are organized as a series of 8-bit data words that can be addressed individually or sequentially.

For more information, please see the SFP MSA documentation¹ or Finisar Application Note AN-2030.

Digital diagnostics for the FTLF1321P1xTL are externally calibrated by default.

Please note that evaluation board FDB-1018 is available with Finisar ModDEMO software that allows simple to use communication over the 2-wire serial interface.

IX. Mechanical Specifications

Finisar’s Small Form Factor Pluggable (SFP) transceivers are compatible with the dimensions defined by the SFP Multi-Sourcing Agreement (MSA)³.

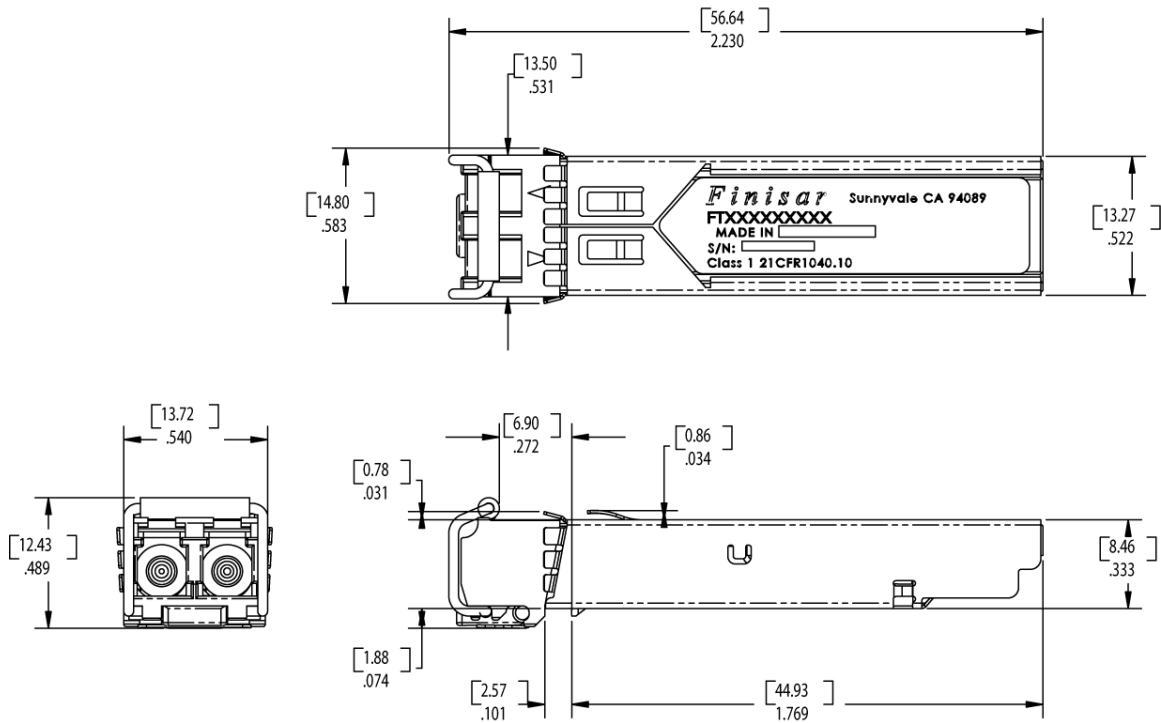

FTLF1321P1BTL

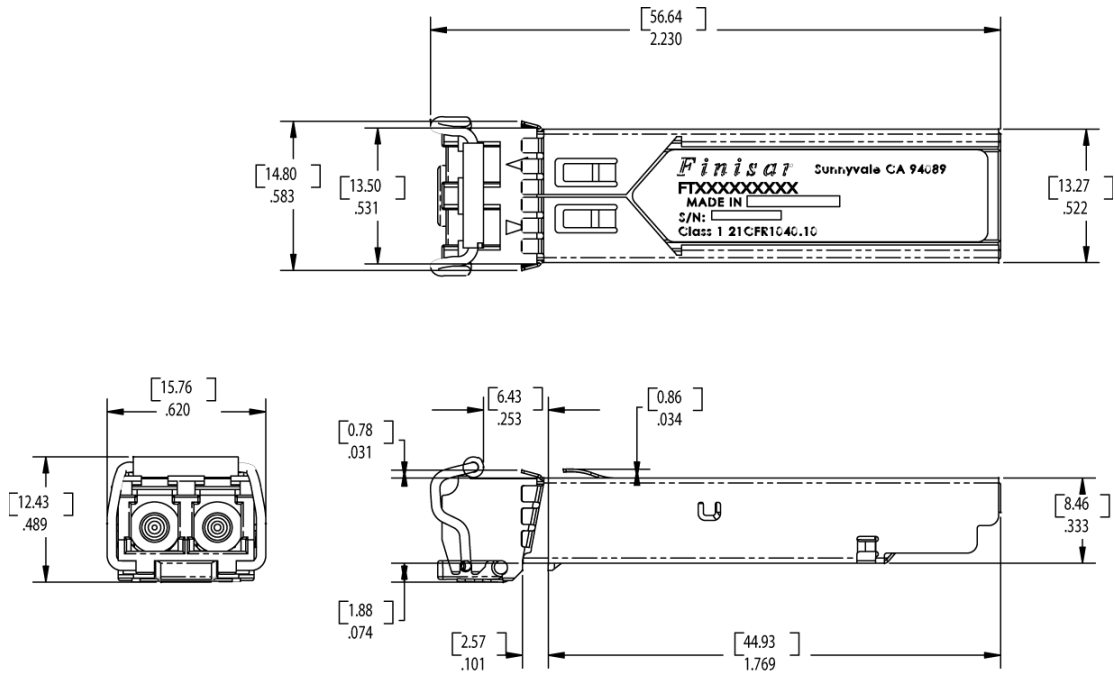

FTLF1321P1WTL

X. PCB Layout and Bezel Recommendations

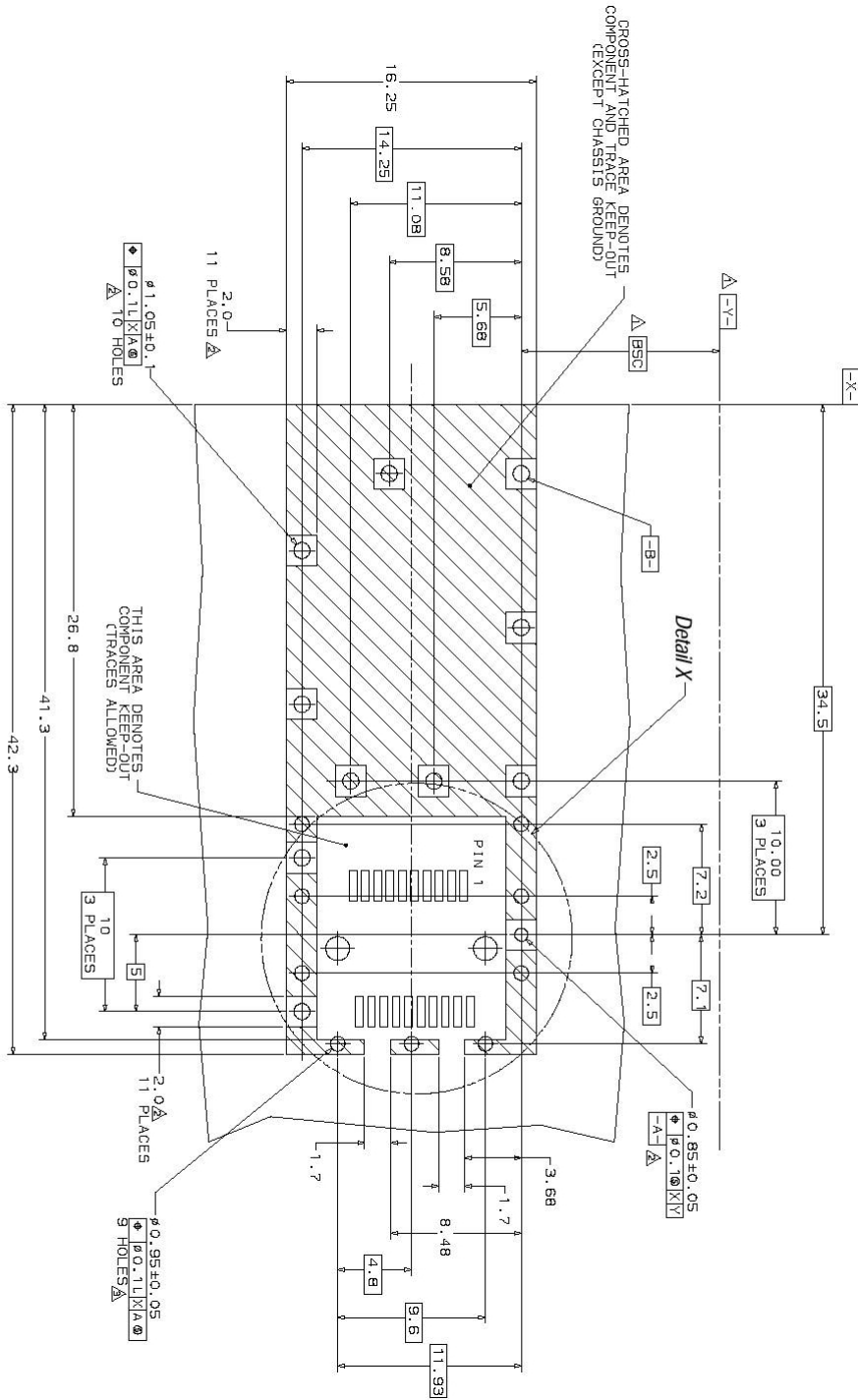

- △ Datum and Basic Dimension Established by Customer
- ⊠ Rads and Vias are Chassis Ground, 11 Places
- △ Through Holes are Unplated

XI. References

1. Small Form Factor Pluggable (SFP) Transceiver Multi-Source Agreement (MSA), September 2000. Documentation is currently available at Finisar upon request.
2. Bellcore GR-253 and ITU-T G.957 Specifications (Transmitter Optical Output Power complies with SONET OC-48 requirements only).
3. IEEE Std 802.3, 2002 Edition, Clause 38, PMD Type 1000BASE-LX. IEEE Standards Department, 2002.
4. “Fibre Channel Draft Physical Interface Specification (FC-PI 13.0)”. American National Standard for Information Systems.
5. Directive 2002/95/EC of the European Council Parliament and of the Council, “on the restriction of the use of certain hazardous substances in electrical and electronic equipment.” January 27, 2003.

XII. Revision History

Revision	Date	Description
C1	03/23/2011	Corrected Rx sensitivity over different bit rates

XIII. For More Information

Finisar Corporation
1389 Moffett Park Drive
Sunnyvale, CA 94089-1134
Tel. 1-408-548-1000
Fax 1-408-541-6138
sales@finisar.com
www.finisar.com