

Red LED for optical link

L9534

Red LED for 125 Mbps optical link

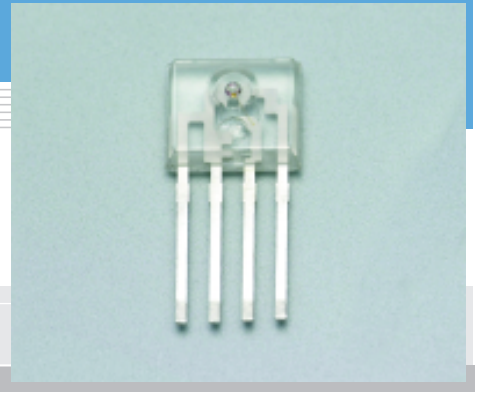

L9534 is a LED ideal for high-speed POF communications. L9534 is sealed in a small plastic package with a lens, allowing easy coupling to an FOP.

Features

- Peak emission wavelength: 650 nm
- High-speed response and high output power

Applications

- Home networks and short-range high-speed data communications

■ Absolute maximum ratings (Ta=25 °C)

Parameter	Symbol	Value	Unit
Forward current	IF	40	mA
Reverse voltage	VR	3	V
Power dissipation *1	Pmax	250	mW
Operating temperature	Topr	-20 to +70	°C
Storage temperature	Tstg	-40 to +85	°C
Soldering	-	230 °C, 5 s, at least 1.8 mm away from package surface	-

*1: Power dissipation going down at a rate of -1.75 mW/°C above Ta=25 °C

■ Electrical and optical characteristics (Ta=25 °C)

Parameter	Symbol	Condition	Min.	Typ.	Max.	Unit
Data rate	fD	NRZ *2	DC	-	125	Mbps
Forward voltage	VF	IF=20 mA	1.8	2.0	2.5	V
Reverse current	IR	VR=3 V	-	-	10	μA
Peak emission wavelength	λp	IF=20 mA	-	650	-	nm
Spectral half width (FWHM)	Δλ	IF=20 mA	-	20	-	nm
Fiber-coupled optical output	PO	*2, 3, 4	-6.5	-	-3	dBm
Pulse distortion	ΔT	*2, 3	-2	-	0	ns
Jitter	Δtj	*2, 3	-	-	1.5	ns

*2: Measured with the recommended driver circuit shown below.

(Vcc=4.75 to 5.25 V, R1=180 Ω, R2=470 Ω, R3=10 Ω, C1=47 pF)

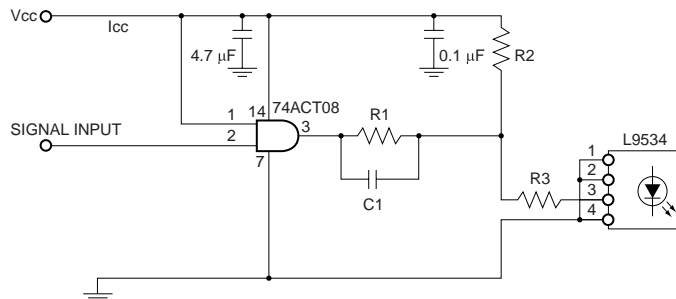

KLEDC0039EA

*3: Input is a pseudo-random bi-phase signal at 125 Mbps (NRZ signal conversion).

*4: Average value (duty ratio 50 %) measured by using a plastic fiber of φ1 mm. SI-POF and NA=0.5 (GH4001 made by Mitsubishi Rayon).

Note)

- A bypass capacitor (0.1 μF) and another capacitor (4.7 μF) are connected between Vcc and GND at a position within 3 mm from the lead.
- The center of the optical fiber is aligned with the center of the lens on the package. The distance between the fiber end and the lens is 0.1 mm.

Dimensional outline (unit: mm)

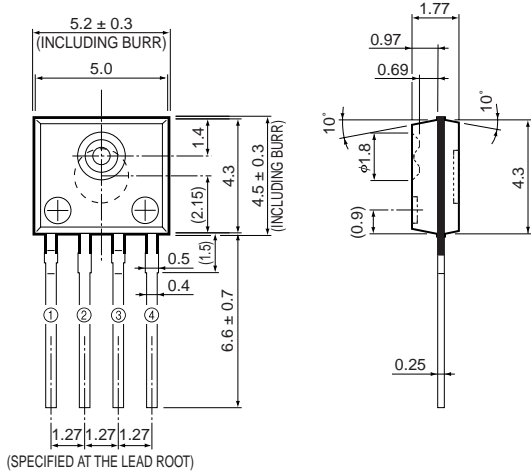

(SPECIFIED AT THE LEAD ROOT)

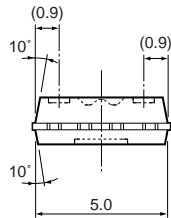

- ① CATHODE
- ② CATHODE
- ③ ANODE
- ④ CATHODE

Tolerance unless otherwise noted: ± 0.1 , $\pm 2^\circ$
 Shaded area indicates burr.
 Values in parentheses indicate reference value.

KLEDA0087EA