



SGM8926

110kHz, Rail-to-Rail Output CMOS Operational Amplifier

PRODUCT DESCRIPTION

The SGM8926 is a low power, low offset voltage and rail-to-rail output voltage feedback amplifier. It has a wide output voltage swing, and takes the minimum operating supply voltage down to 1.6V. The maximum recommended supply voltage is 5.5V.

The SGM8926 provides 110kHz bandwidth at a low current consumption of 6.4 μ A per amplifier. Very low input bias currents of 1pA enable this amplifier to be used for integrators, photodiode amplifiers, and piezoelectric sensors. Rail-to-rail output is useful to designers for buffering ASIC in single-supply systems.

Applications for this amplifier also include safety monitoring, portable equipment, battery and power supply control, signal conditioning and interfacing for transducers in very low power systems.

The SGM8926 dual is available in Green MSOP-8 and SOIC-8 packages. It is specified over the extended -40°C to +85°C temperature range.

FEATURES

- **Low Offset Voltage: 0.9mV (MAX)**
- **Rail-to-Rail Output**
- **Unity Gain Stable**
- **Gain-Bandwidth Product: 110kHz**
- **Supply Voltage Range: 1.6V to 5.5V**
- **Low Supply Current: 6.4 μ A/Amplifier (TYP)**
- **Small Packaging:**
Available in Green SOIC-8 and MSOP-8 Packages

APPLICATIONS

- ASIC Input or Output Amplifier
- Sensor Interface
- Piezoelectric Transducer Amplifier
- Medical Instrumentation
- Mobile Communication
- Audio Output
- Portable Systems
- Smoke Detectors
- Mobile Telephone
- Notebook PC
- PCMCIA Cards
- Battery-Powered Equipment

PACKAGE/ORDERING INFORMATION

MODEL	PACKAGE DESCRIPTION	SPECIFIED TEMPERATURE RANGE	ORDER NUMBER	MARKING INFORMATION	PACKAGE OPTION
SGM8926	SOIC-8	-40°C to +85°C	SGM8926YS8G/TR	SGM 8926YS8 XXXXX	Tape and Reel, 2500
	MSOP-8	-40°C to +85°C	SGM8926YMS8G/TR	SGM8926 YMS8 XXXXX	Tape and Reel, 3000

NOTE: XXXXX = Date Code and Vendor Code.

ABSOLUTE MAXIMUM RATINGS

Supply Voltage, +V_S to -V_S6V
 Input Common Mode Voltage Range
 (-V_S) - 0.1V to (+V_S) - 1.3V
 Storage Temperature Range.....-65°C to +150°C
 Junction Temperature150°C
 Operating Temperature Range..... -40°C to +85°C
 Lead Temperature (Soldering 10sec)
260°C
 ESD Susceptibility
 HBM.....8000V
 MM400V

NOTE:

Stresses beyond those listed under “Absolute Maximum Ratings” may cause permanent damage to the device. These are stress ratings only, and functional operation of the device at these or any other conditions beyond those indicated in the operational sections of the specifications is not implied. Exposure to absolute maximum rating conditions for extended periods may affect device reliability.

CAUTION

This integrated circuit can be damaged by ESD if you don't pay attention to ESD protection. SGMICRO recommends that all integrated circuits be handled with appropriate precautions. Failure to observe proper handling and installation procedures can cause damage. ESD damage can range from subtle performance degradation to complete device failure. Precision integrated circuits may be more susceptible to damage because very small parametric changes could cause the device not to meet its published specifications.

SGMICRO reserves the right to make any change in circuit design, specification or other related things if necessary without notice at any time. Please contact SGMICRO sales office to get the latest datasheet.

PIN CONFIGURATIONS (TOP VIEW)

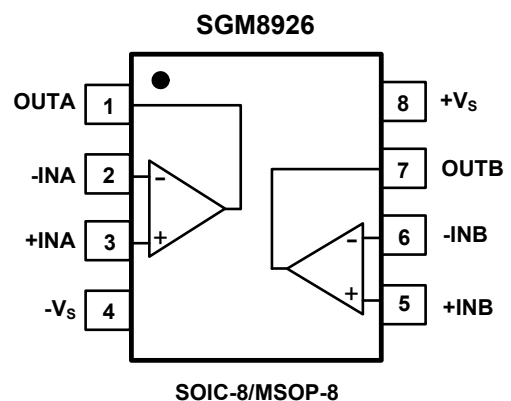

ELECTRICAL CHARACTERISTICS: $V_S = +5V$ (At $T_A = +25^\circ\text{C}$, $V_{OUT} = V_S/2$, unless otherwise noted.)

PARAMETER	CONDITIONS	MIN	TYP	MAX	UNITS
DC PERFORMANCE					
Input Offset Voltage (V_{OS})	$V_{CM} = V_S/2$		0.15	0.9	mV
Input Offset Voltage Drift ($\Delta V_{OS}/\Delta T$)			2.5		$\mu\text{V}/^\circ\text{C}$
Open-Loop Voltage Gain (A_{OL})	$R_L = 100\text{k}\Omega$ to $V_S/2$, $V_{OUT} = 0.05\text{V}$ to 4.95V		93		dB
	$R_L = 10\text{k}\Omega$ to $V_S/2$, $V_{OUT} = 0.15\text{V}$ to 4.85V	80	88		
	$-40^\circ\text{C} \leq T_A \leq +85^\circ\text{C}$	77			
INPUT CHARACTERISTICS					
Common Mode Rejection Ratio (CMRR)	$V_{CM} = -0.1\text{V}$ to 3.7V	69	85		dB
	$-40^\circ\text{C} \leq T_A \leq +85^\circ\text{C}$	67			
OUTPUT CHARACTERISTICS					
Output Voltage Swing from Rail	$R_L = 10\text{k}\Omega$ to $V_S/2$		21	39	mV
	$-40^\circ\text{C} \leq T_A \leq +85^\circ\text{C}$			42	
	$R_L = 2\text{k}\Omega$ to $V_S/2$		80	105	mV
	$-40^\circ\text{C} \leq T_A \leq +85^\circ\text{C}$			115	
Output Short-Circuit Current (I_{SC})	$R_L = 10\Omega$ to $V_S/2$	24	36		mA
	$-40^\circ\text{C} \leq T_A \leq +85^\circ\text{C}$	18			
POWER SUPPLY					
Quiescent Current/Amplifier (I_Q)	$I_{OUT} = 0\text{mA}$		6.4	11.5	μA
	$-40^\circ\text{C} \leq T_A \leq +85^\circ\text{C}$			14	
Power Supply Rejection Ratio (PSRR)	$V_S = +1.6\text{V}$ to $+5.5\text{V}$, $V_{CM} = 0.3\text{V}$	64	77		dB
	$-40^\circ\text{C} \leq T_A \leq +85^\circ\text{C}$	62			
DYNAMIC PERFORMANCE					
Gain-Bandwidth Product (GBP)	$R_L = 100\text{k}\Omega$, $C_L = 100\text{pF}$, $V_{CM} = 2.5\text{V}$		110		kHz
Slew Rate (SR)	$V_{CM} = 2.5\text{V}$		0.04		$\text{V}/\mu\text{s}$
Crosstalk	$f = 1\text{kHz}$		90		dB
NOISE PERFORMANCE					
Input Voltage Noise (e_n)	$f = 1\text{kHz}$		105		$\text{nV}/\sqrt{\text{Hz}}$

ELECTRICAL CHARACTERISTICS: $V_S = +1.6V$ (At $T_A = +25^\circ C$, $V_{CM} = 0.3V$, $V_{OUT} = V_S/2$, unless otherwise noted.)

PARAMETER	CONDITIONS	MIN	TYP	MAX	UNITS
DC PERFORMANCE					
Input Offset Voltage (V_{OS})			0.25	0.9	mV
Input Offset Voltage Drift ($\Delta V_{OS}/\Delta T$)			1.8		$\mu V/^\circ C$
Open-Loop Voltage Gain (A_{OL})	$R_L = 100k\Omega$ to $V_S/2$, $V_{OUT} = 0.05V$ to $1.55V$		99		dB
	$R_L = 10k\Omega$ to $V_S/2$, $V_{OUT} = 0.15V$ to $1.45V$	79	91		
	$-40^\circ C \leq T_A \leq +85^\circ C$	78			
INPUT CHARACTERISTICS					
Common Mode Rejection Ratio (CMRR)	$V_{CM} = -0.1V$ to $0.3V$	64	78		dB
	$-40^\circ C \leq T_A \leq +85^\circ C$	62			
OUTPUT CHARACTERISTICS					
Output Voltage Swing from Rail	$R_L = 10k\Omega$ to $V_S/2$		13	25	mV
	$-40^\circ C \leq T_A \leq +85^\circ C$			28	
	$R_L = 2k\Omega$ to $V_S/2$		63	87	mV
	$-40^\circ C \leq T_A \leq +85^\circ C$			90	
Output Short-Circuit Current (I_{SC})	$R_L = 10\Omega$ to $V_S/2$	0.4	2.6		mA
	$-40^\circ C \leq T_A \leq +85^\circ C$	0.25			
POWER SUPPLY					
Quiescent Current/Amplifier (I_Q)	$I_{OUT} = 0mA$		5.8	10	μA
	$-40^\circ C \leq T_A \leq +85^\circ C$			13.5	
DYNAMIC PERFORMANCE					
Gain-Bandwidth Product (GBP)	$R_L = 100k\Omega$, $C_L = 100pF$		110		kHz
Slew Rate (SR)			0.04		$V/\mu s$
Crosstalk	$f = 1kHz$		90		dB
NOISE PERFORMANCE					
Input Voltage Noise (e_n)	$f = 1kHz$		105		nV/\sqrt{Hz}

TYPICAL PERFORMANCE CHARACTERISTICS

At $T_A = +25^\circ\text{C}$, $V_S = 5\text{V}$, unless otherwise noted.

Small Signal Step Response

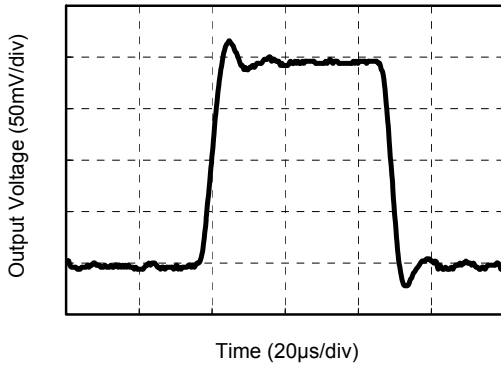

Large Signal Step Response

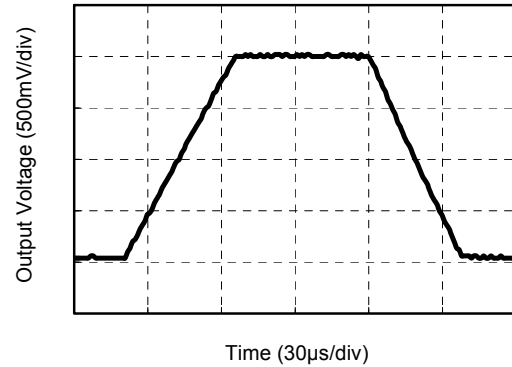

CMRR and PSRR vs. Frequency

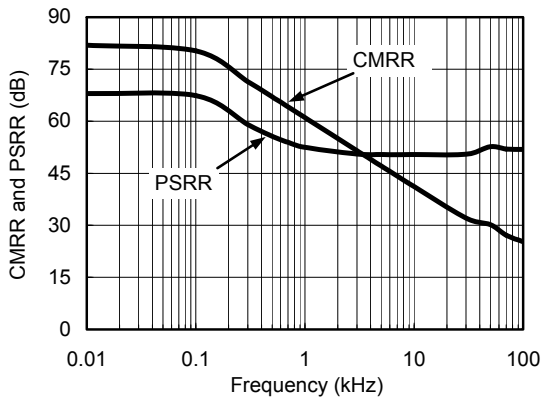

Input Voltage Noise Spectral Density vs. Frequency

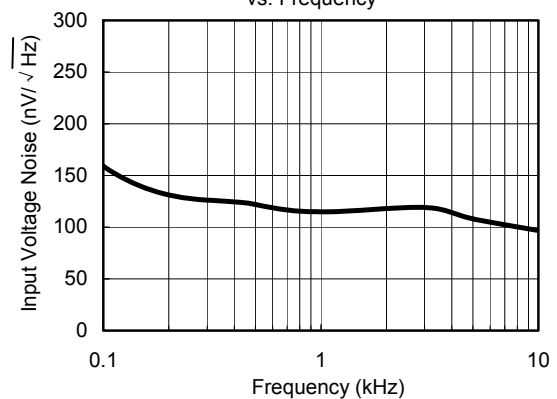

Quiescent Current/Amplifier vs. Temperature

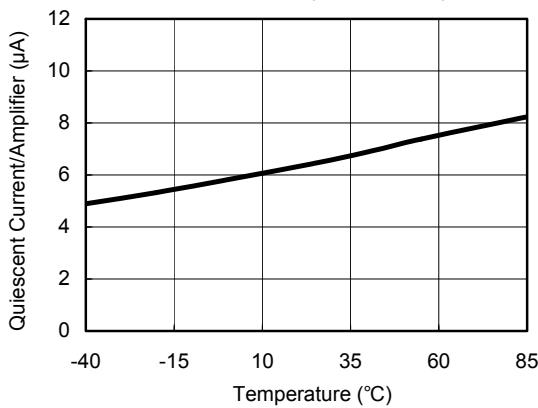

Output Voltage vs. Output Current

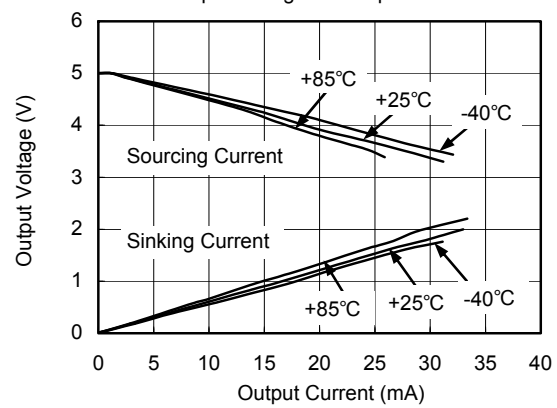

TYPICAL PERFORMANCE CHARACTERISTICS

At $T_A = +25^\circ\text{C}$, $V_S = 5\text{V}$, unless otherwise noted.

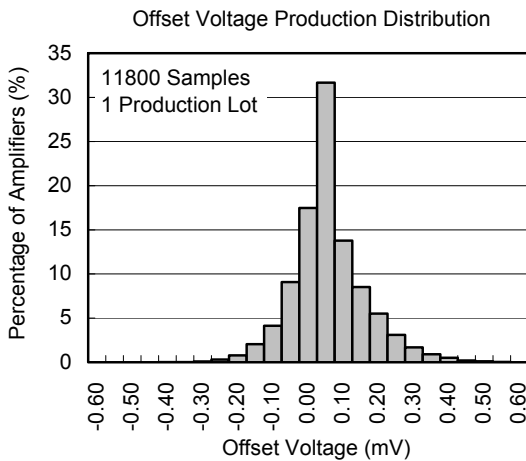
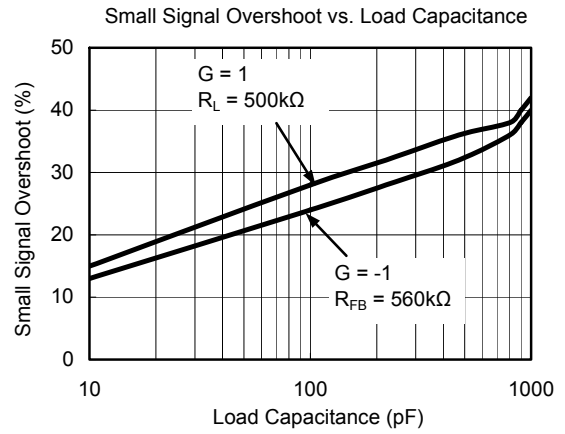
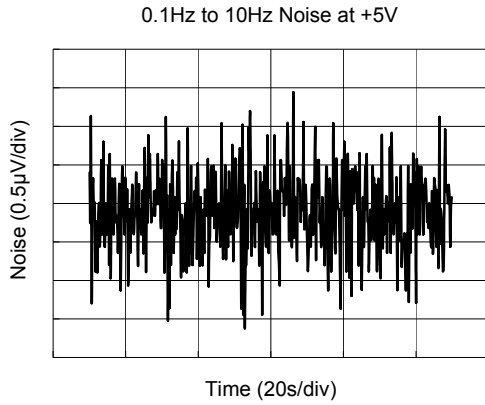

PACKAGE OUTLINE DIMENSIONS

SOIC-8

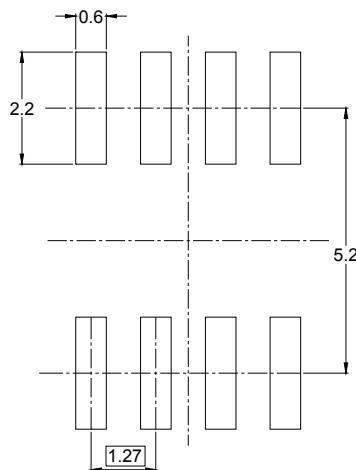
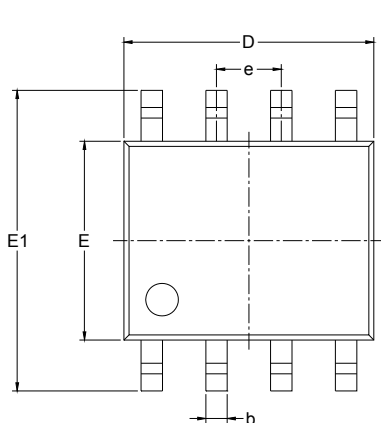

RECOMMENDED LAND PATTERN (Unit: mm)

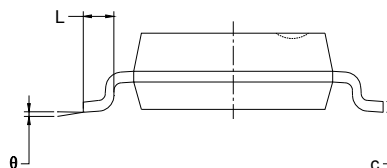
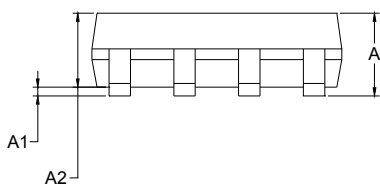

Symbol	Dimensions In Millimeters		Dimensions In Inches	
	MIN	MAX	MIN	MAX
A	1.350	1.750	0.053	0.069
A1	0.100	0.250	0.004	0.010
A2	1.350	1.550	0.053	0.061
b	0.330	0.510	0.013	0.020
c	0.170	0.250	0.006	0.010
D	4.700	5.100	0.185	0.200
E	3.800	4.000	0.150	0.157
E1	5.800	6.200	0.228	0.244
e	1.27 BSC		0.050 BSC	
L	0.400	1.270	0.016	0.050
θ	0°	8°	0°	8°

PACKAGE OUTLINE DIMENSIONS

MSOP-8

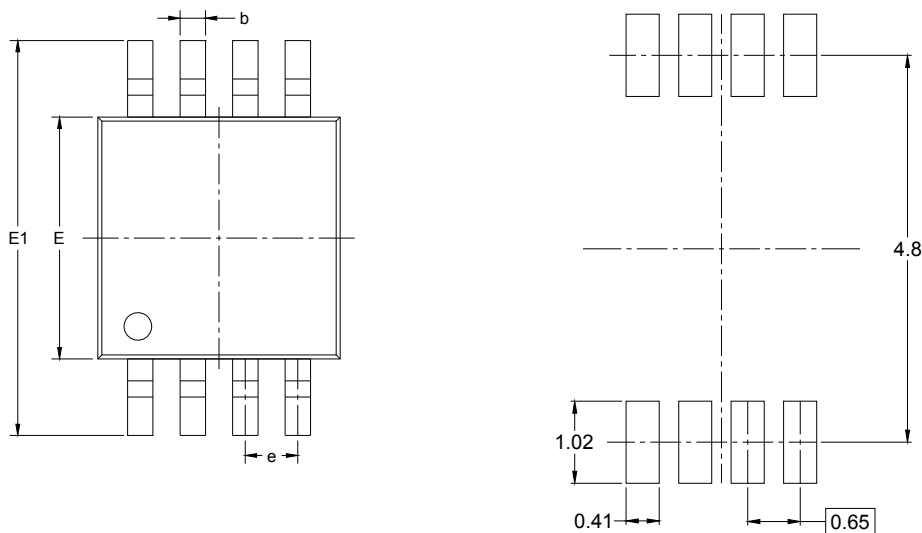

RECOMMENDED LAND PATTERN (Unit: mm)

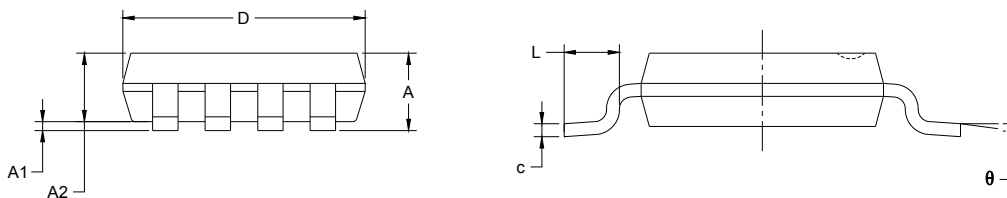

Symbol	Dimensions In Millimeters		Dimensions In Inches	
	MIN	MAX	MIN	MAX
A	0.820	1.100	0.032	0.043
A1	0.020	0.150	0.001	0.006
A2	0.750	0.950	0.030	0.037
b	0.250	0.380	0.010	0.015
c	0.090	0.230	0.004	0.009
D	2.900	3.100	0.114	0.122
E	2.900	3.100	0.114	0.122
E1	4.750	5.050	0.187	0.199
e	0.650 BSC		0.026 BSC	
L	0.400	0.800	0.016	0.031
θ	0°	6°	0°	6°

TAPE AND REEL INFORMATION

REEL DIMENSIONS

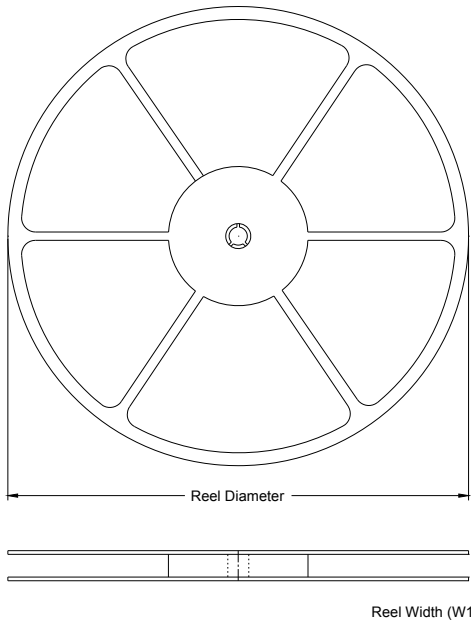

TAPE DIMENSIONS

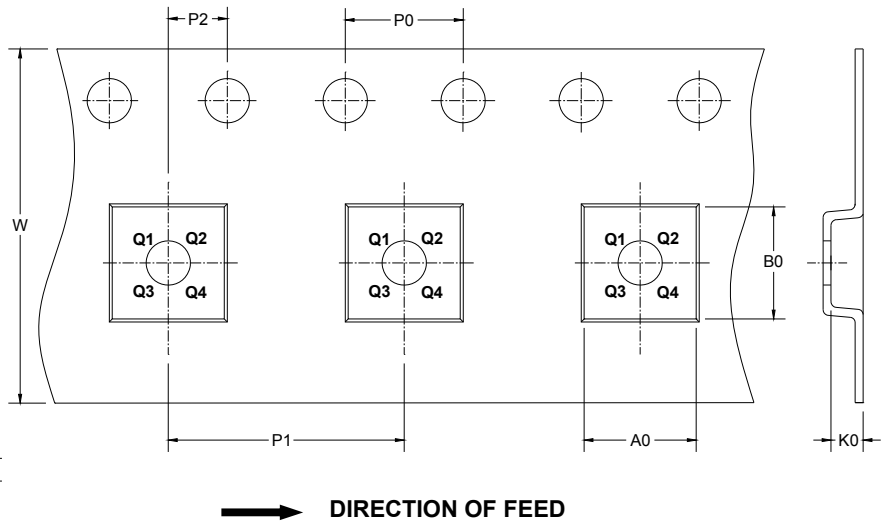

NOTE: The picture is only for reference. Please make the object as the standard.

KEY PARAMETER LIST OF TAPE AND REEL

Package Type	Reel Diameter	Reel Width W1 (mm)	A0 (mm)	B0 (mm)	K0 (mm)	P0 (mm)	P1 (mm)	P2 (mm)	W (mm)	Pin1 Quadrant
SOIC-8	13"	12.4	6.4	5.4	2.1	4.0	8.0	2.0	12.0	Q1
MSOP-8	13"	12.4	5.2	3.3	1.5	4.0	8.0	2.0	12.0	Q1

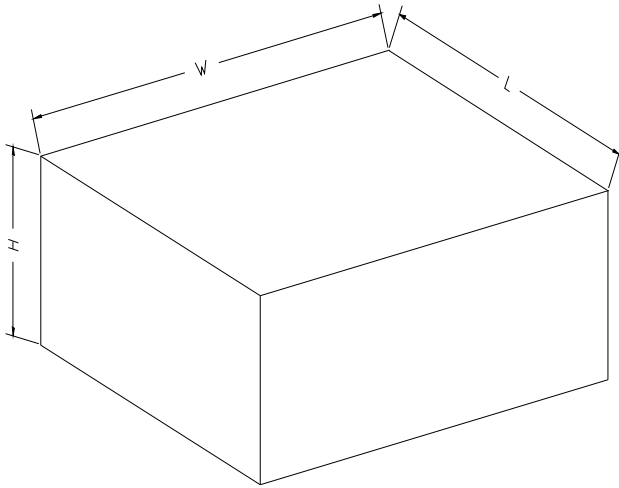
CARTON BOX DIMENSIONS

NOTE: The picture is only for reference. Please make the object as the standard.

KEY PARAMETER LIST OF CARTON BOX

Reel Type	Length (mm)	Width (mm)	Height (mm)	Pizza/Carton
13"	386	280	370	5