

Silicon PNP Power Transistors

2N4901 2N4902 2N4903

DESCRIPTION

- With TO-3 package
- Complement to type 2N5067/5068/5069
- Low collector saturation voltage

APPLICATIONS

- For general-purpose switching and power amplifier applications.

PINNING

PIN	DESCRIPTION
1	Base
2	Emitter
3	Collector

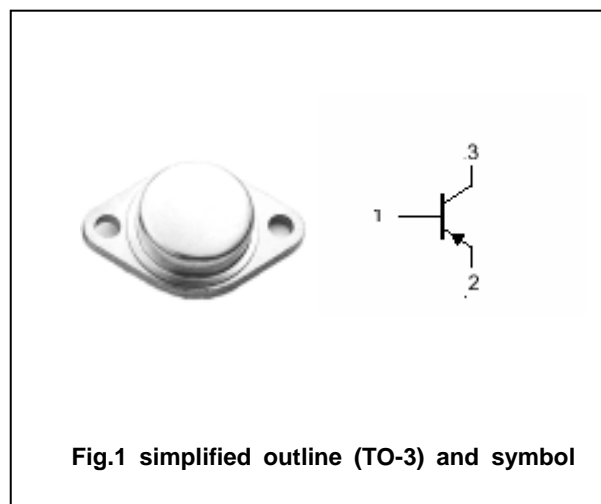

Fig.1 simplified outline (TO-3) and symbol

Absolute maximum ratings(Ta=)

SYMBOL	PARAMETER	CONDITIONS	VALUE	UNIT
V _{CBO}	Collector-base voltage	2N4901	-40	V
		2N4902	-60	
		2N4903	-80	
V _{CEO}	Collector-emitter voltage	2N4901	-40	V
		2N4902	-60	
		2N4903	-80	
V _{EBO}	Emitter-base voltage	Open collector	-5	V
I _C	Collector current		-5	A
I _{CM}	Collector current-peak		-10	A
I _B	Base current		-1	A
P _D	Total power dissipation	T _C =25	87.5	W
T _j	Junction temperature		200	
T _{stg}	Storage temperature		-65~200	

THERMAL CHARACTERISTICS

SYMBOL	PARAMETER	VALUE	UNIT
R _{th j-c}	Thermal resistance junction to case	2.0	/W

Silicon PNP Power Transistors

2N4901 2N4902 2N4903

CHARACTERISTICS

T_j=25 unless otherwise specified

SYMBOL	PARAMETER		CONDITIONS	MIN	TYP.	MAX	UNIT
V _{CE0(SUS)}	Collector-emitter sustaining voltage	2N4901	I _C =-0.2A ; I _B =0	-40			V
		2N4902		-60			
		2N4903		-80			
V _{CEsat-1}	Collector-emitter saturation voltage		I _C =-1A; I _B =-0.1A			-0.4	V
V _{CEsat-2}	Collector-emitter saturation voltage		I _C =-5A ; I _B =-1A			-1.5	V
V _{BE}	Base-emitter on voltage		I _C =-1A ; V _{CE} =-2V			-1.2	V
I _{CEO}	Collector cut-off current		V _{CE} =Rated V _{CE0} ; I _B =0			-1.0	mA
I _{CBO}	Collector cut-off current		V _{CB} =Rated V _{CBO} ; I _E =0			-0.1	mA
I _{CEX}	Collector cut-off current		V _{CE} = Rated V _{CE0} ; V _{BE(off)} =1.5V T _C =150			-1.0 -2.0	mA
I _{EBO}	Emitter cut-off current		V _{EB} =-5V; I _C =0			-1.0	mA
h _{FE-1}	DC current gain		I _C =-1A ; V _{CE} =-2V	20		80	
h _{FE-2}	DC current gain		I _C =-5A ; V _{CE} =-2V	7			
f _T	Transition frequency		I _C =-1A ; V _{CE} =-10V	4			MHz

Silicon PNP Power Transistors

2N4901 2N4902 2N4903

PACKAGE OUTLINE

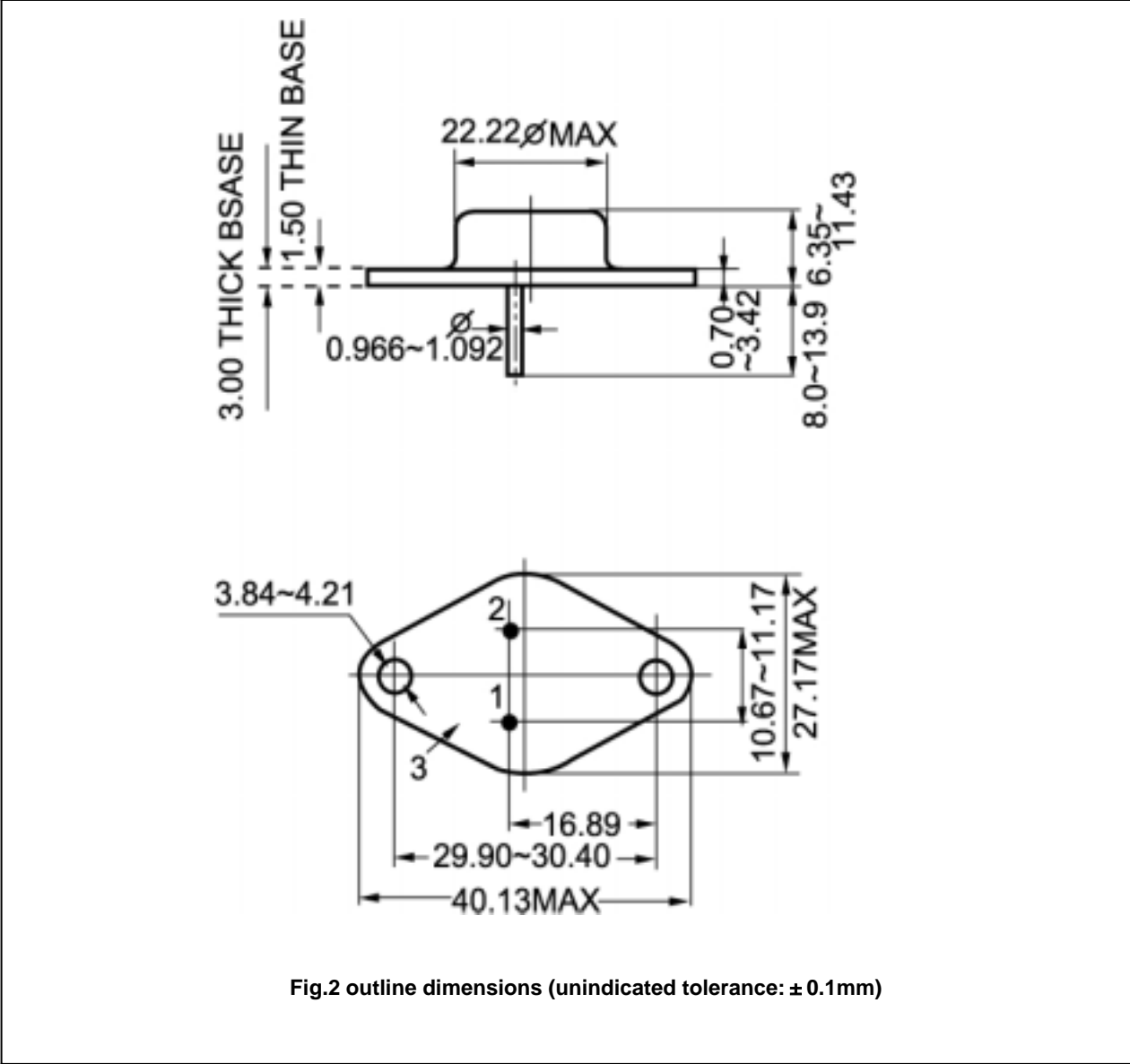

Fig.2 outline dimensions (unindicated tolerance: ± 0.1mm)