

Protection in Portable Electronics Applications.

FEATURES

- Transient protection for data lines to
 - IEC61000-4-2(ESD) : Air mode $\pm 20\text{kV}$ / Contact mode $\pm 15\text{kV}$
 - IEC 61000-4-4(EFT) : $\pm 50\text{A}$ (5/50ns)
 - IEC 61000-4-5(Surge) : 4A (tp=8/20 μs)
- Low capacitance $C_T = 0.5\text{pF}$ (Max)
- Bi-directional, symmetrical working voltage up to : $V_{RWM} = \pm 5\text{V}$
- Extremely small Size $0.6 \times 0.3 \times 0.28\text{mm}^2$
- Low reverse current : 5nA typical ($V_R=5\text{V}$)



ELP-2A (leadless-type)

PRODUCT DESCRIPTION

- Molding compound flammability rating : UL 94V-0
- Pb-Free, Halogen-Free, RoHs Compliant

| Package dimensions (ELP-2A) | Pin configurations (Bi-directional) | | | | | | | | | | | | | | | | | | | | |
|---|-------------------------------------|-------------|---|-----------------|---|-----------------|---|-----------------|---|-----------------|---|-----------------|---|---------|---|-----------------|---|---------|---|---------|-----------------------------|
| <table border="1"> <thead> <tr> <th>DIM</th> <th>MILLIMETERS</th> </tr> </thead> <tbody> <tr> <td>A</td> <td>0.6 ± 0.025</td> </tr> <tr> <td>B</td> <td>0.3 ± 0.025</td> </tr> <tr> <td>C</td> <td>0.28 ± 0.02</td> </tr> <tr> <td>D</td> <td>0.24 ± 0.01</td> </tr> <tr> <td>E</td> <td>0.14 ± 0.01</td> </tr> <tr> <td>F</td> <td>Typ 0.4</td> </tr> <tr> <td>G</td> <td>0.03 ± 0.02</td> </tr> <tr> <td>H</td> <td>Max 0.3</td> </tr> <tr> <td>I</td> <td>Typ 0.1</td> </tr> </tbody> </table> | DIM | MILLIMETERS | A | 0.6 ± 0.025 | B | 0.3 ± 0.025 | C | 0.28 ± 0.02 | D | 0.24 ± 0.01 | E | 0.14 ± 0.01 | F | Typ 0.4 | G | 0.03 ± 0.02 | H | Max 0.3 | I | Typ 0.1 | <p>1. ANODE 2. ANODE</p> |
| DIM | MILLIMETERS | | | | | | | | | | | | | | | | | | | | |
| A | 0.6 ± 0.025 | | | | | | | | | | | | | | | | | | | | |
| B | 0.3 ± 0.025 | | | | | | | | | | | | | | | | | | | | |
| C | 0.28 ± 0.02 | | | | | | | | | | | | | | | | | | | | |
| D | 0.24 ± 0.01 | | | | | | | | | | | | | | | | | | | | |
| E | 0.14 ± 0.01 | | | | | | | | | | | | | | | | | | | | |
| F | Typ 0.4 | | | | | | | | | | | | | | | | | | | | |
| G | 0.03 ± 0.02 | | | | | | | | | | | | | | | | | | | | |
| H | Max 0.3 | | | | | | | | | | | | | | | | | | | | |
| I | Typ 0.1 | | | | | | | | | | | | | | | | | | | | |

ORDERING INFORMATION

| Part Number | Qty per Reel | Reel Size | Marking code |
|----------------|--------------|-----------|--------------|
| PS05TBEL2A-RTK | 5,000 | 7 inch | S |
| PS05TBEL2A-RTL | 10,000 | | |
| PS05TBEL2A-RTH | 5,000 | | |
| PS05TBEL2A-RTR | 10,000 | | |

PS05TBEL2A

MAXIMUM RATING (Ta=25)

| CHARACTERISTIC | SYMBOL | RATING | UNIT |
|---------------------------------|------------------|---------|------|
| Peak Pulse Power (tp=8/20 μs) | P _{PK} | 60 | W |
| Peak Pulse Current (tp=8/20 μs) | I _{PP} | 4 | A |
| Junction Temperature | T _J | 150 | |
| Storage Temperature | T _{stg} | -55 150 | |

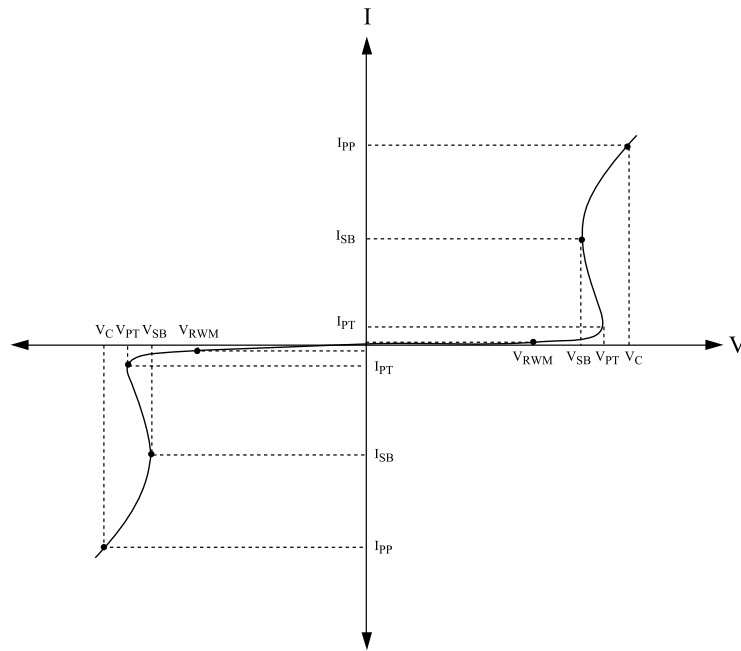

ELECTRICAL CHARACTERISTICS (Ta=25)

| CHARACTERISTIC | SYMBOL | TEST CONDITION | MIN. | TYP. | MAX. | UNIT |
|---------------------------|------------------|---------------------------------|---------|------|------|------|
| Reverse Stand-Off Voltage | V _{RWM} | - | - | - | 5 | V |
| Reverse Leakage Current | I _R | V _{RWM} =5V | - | 5 | 100 | nA |
| Snab-back Voltage | V _{SB} | - | 5.5 | - | - | V |
| Punch-through Voltage | V _{PT} | - | 6 | - | - | V |
| Total Capacitance | C _T | V _R =0V, f=1MHz | - | 0.35 | 0.5 | pF |
| Clamping Voltage | V _C | I _{PP} =1A, tp=8/20 μs | - | 10 | 13 | V |
| | | I _{PP} =4A, tp=8/20 μs | - | 12 | 15 | |
| | | I _{TLP} =4A, tp=100ns | - | 11 | 15 | |
| | | I _{TLP} =16A, tp=100ns | - | 21 | 25 | |
| Electrstatic Discharge | V _{ESD} | IEC61000-4-2 | Air | ± 20 | - | kV |
| | | | Contact | ± 15 | - | |

PS05TBEL2A

NON-REPETITIVE PEAK PULSE
POWER VS. PULSE TIME

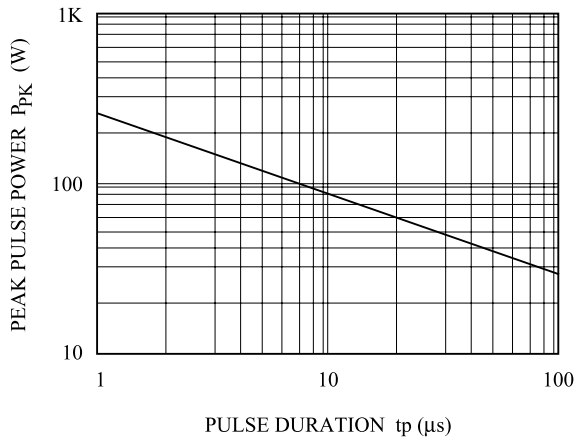

POWER DERATION CURVE

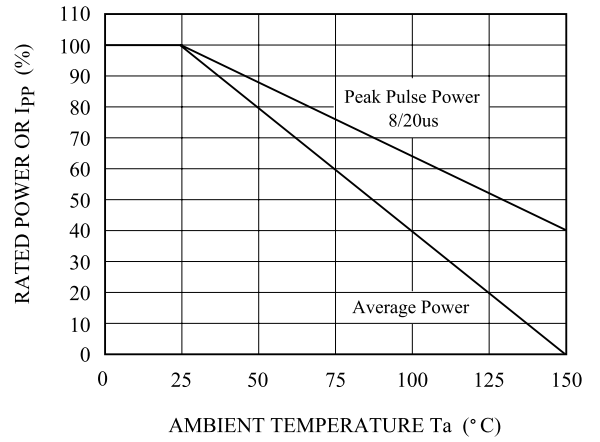

$I_R - V_R$

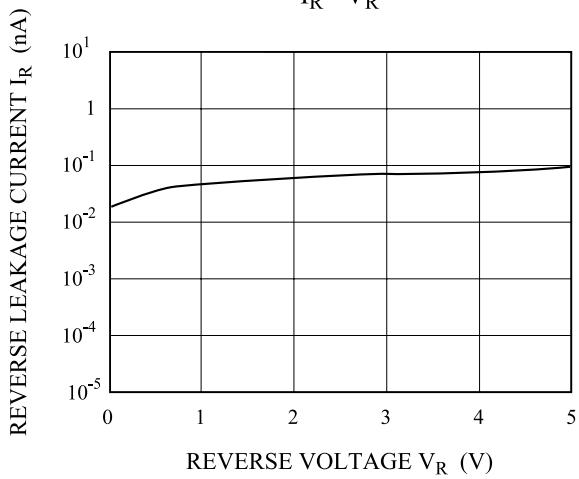

$C_T - V_R$

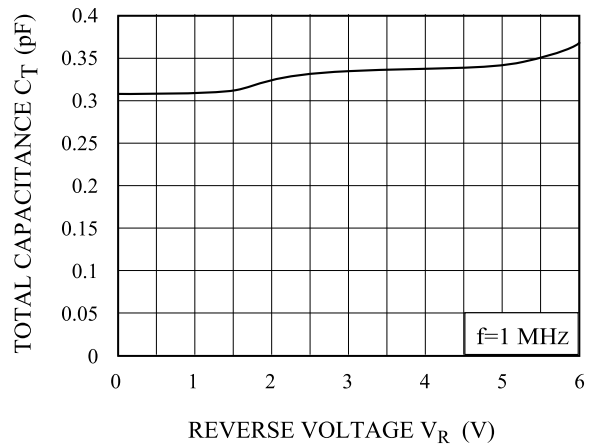

$V_C - I_{pp}$

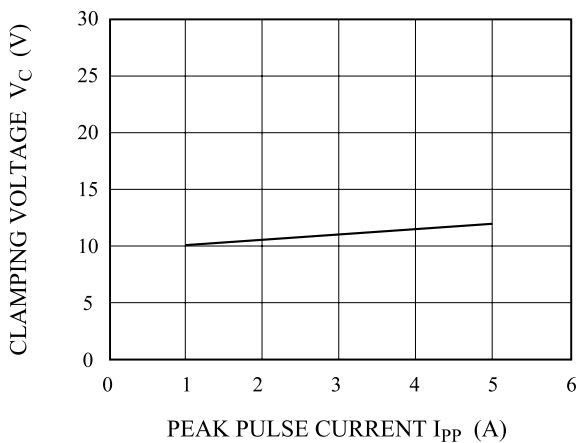

TLP CURVE

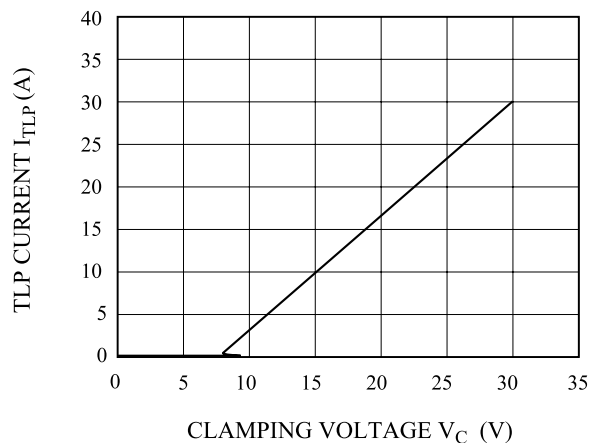

PS05TBEL2A

ESD Clamping
(+8 kV Contact per IEC 61000-4-2)

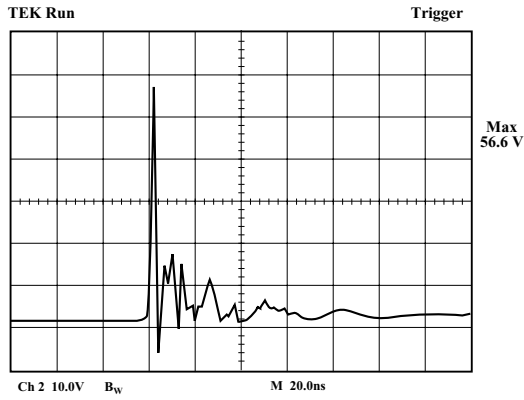

Note : Data is taken with a 10x attenuator

ESD Clamping
(-8 kV Contact per IEC 61000-4-2)

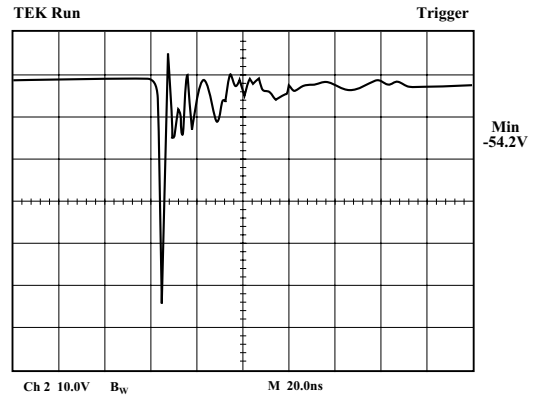

Note : Data is taken with a 10x attenuator

PULSE WAVEFORM

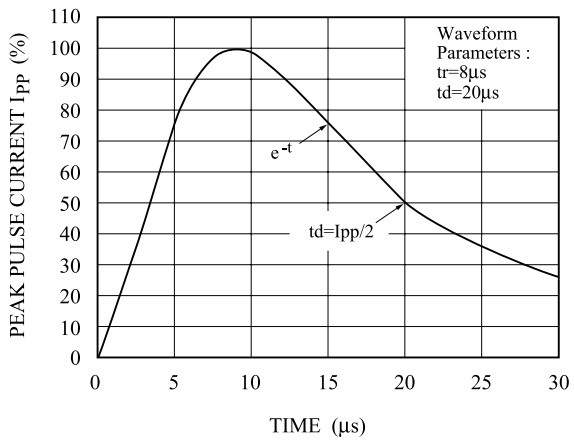

PS05TBEL2A

APPLICATIONS

- USB 2.0, 10/100/1000 Ethernet, DVI, HDMI, S-ATA
- MDDI Port
- LCD-Display, Camera
- GPS / FM Antennas
- LVDS
- High speed data lines

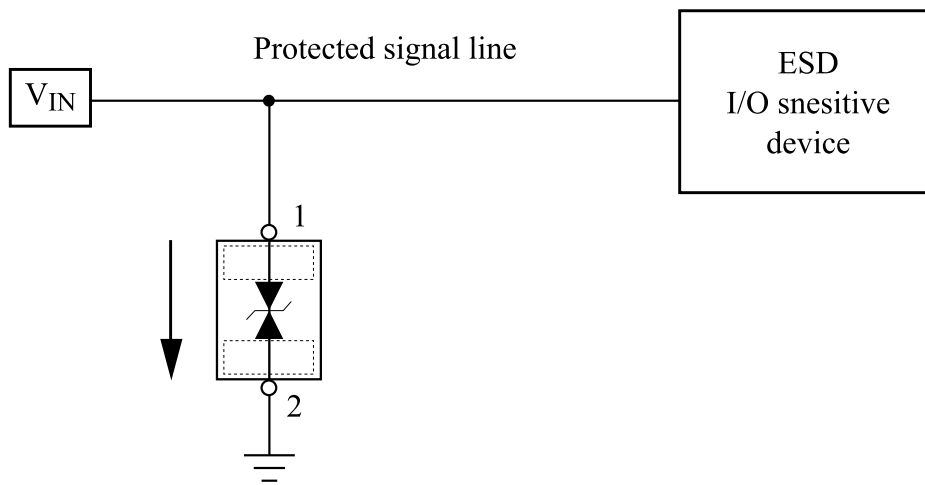

Recommended pad dimension & Marking Information

| Recommended pad dimension | Marking Code |
|--|--|
| <p>Diagram showing the recommended pad dimensions for the diode. The pad width is 0.21, the pad height is 0.3, and the distance between pads is 0.4.</p> | <p>Diagram showing the marking code 'S' on the diode package. The cathode is marked with '2' and the anode with '1'. A 'CATHODE MARK' is indicated on the cathode pad.</p> |