

Tritium II PA-Duplexer Module™ CDMA PCS Band

Functional Block Diagram

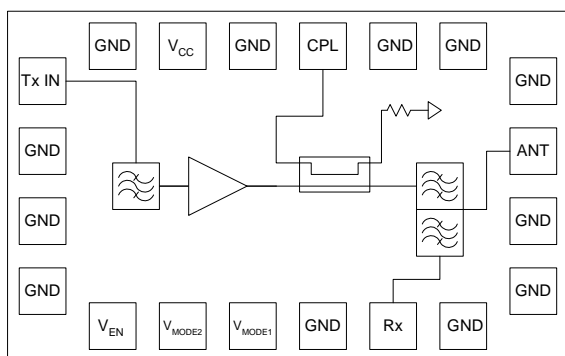

Product Description

The TQM663029A is a fully matched CDMA PCS band PA-Duplexer module for use in mobile phones and part of TriQuint's Tritium III product family. The module is designed with a focus on size, current consumption and phone layout simplicity. Within a compact area of only 28mm², the module integrates a single-ended transmit filter, duplexer, high efficiency PA die, RF power coupler, matching and built in voltage regulator functionality eliminating the need for external switch circuitry. With an RF power output up to 26dBm the TQM663029A meets the strict ACPR/ALTR requirements of multi-band, feature-rich CDMA2000 handset designs.

The module will provide the lowest overall current consumption available in the market based on the current sub-urban CDG (CDMA Development Group) curve by providing a 3 Gain state amplifier. In Low-Power mode operation a quiescent current of only 5mA will allow the module to achieve an overall average current of less than 44mA including RFT currents. The pin layout is optimized for use with new CDMA discrete and packaged transceiver solutions although its operation is backwards compatible with existing chipsets.

Electrical Specifications

Test Conditions V_{CC}=3.4V, V_{EN}=High, T=25°C

| Parameter | Typ | Units |
|---|------|--------|
| Frequency | 1880 | MHz |
| Max P _{OUT} | 26 | dBm |
| ACPR (±1.25MHz offset) | -52 | dBc |
| ALTR (±1.98MHz offset) | -60 | dBc |
| Current Consumption (at +25dBm P _{out}) | 380 | mA |
| Quiescent Current in LPM | 5 | mA |
| Leakage at Rx Port | -38 | dBm |
| Rx Noise | -183 | dBm/Hz |

Features

- Compact 7.0x4.0x1.1mm module replacing more than 16 discrete components
- Integrated duplexer, single-ended Tx filter, PA die, RF power coupler and matching
- Built-in voltage regulator functionality eliminating any external switch circuitry
- High efficiency three gain state PA for lowest overall current consumption
- Typical quiescent current values:
 Low Power Mode (LPM) = 5mA
 Medium Power Mode (MPM) = 17mA
 High Power Mode (HPM) = 85mA
- Low Current Consumption
 Typical: 350 mA @ +25dBm
 Typical: 43 mA @ +13dBm
- Excellent ACPR
 Typical: -52 dBc @ +/- 1.25 MHz offset
- Excellent ALTR
 Typical: -60 dBc @ +/- 1.98 MHz offset
- Lead-free 260°C RoHS Compliant
- Halogen-free (HF)
- Utilizes TriQuint BAW Duplexer Technology

Applications

- IS-95/98/CDMA2000
- EVDO Rev A Compliant
- Single/Dual/Tri-band CDMA Cellular radios

Package Style

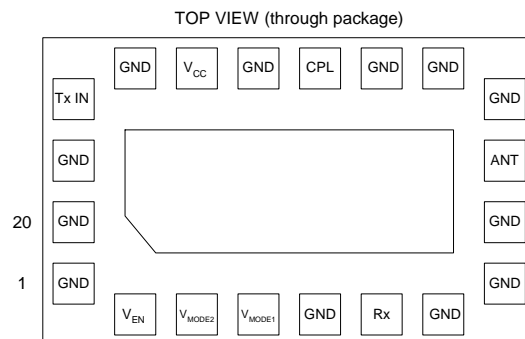

Tritium II PA-Duplexer Module™ CDMA PCS Band

Absolute Maximum Ratings

| Symbol | Parameter | Absolute Maximum Value | Units |
|---|---|------------------------|-------|
| V _{CC} | Supply Voltage with no RF applied | +6.0 | V |
| | Supply Voltage with RF applied | +4.7 | V |
| V _{MODE1} , V _{MODE2} | Mode Control Voltages | +3.3 | V |
| P _{IN} | Input RF Power at Tx Port | +13 | dBm |
| | Input RF Power at Antenna Port | +30 | dBm |
| | Input RF Power at Rx Port | +10 | dBm |
| T _C | Case Temperature, Survival | -35 to +95 | °C |
| T _{STG} | Storage Temperature | -55 to +125 | °C |
| ESD | ESD meets class 1B Human Body Model (HBM) rating under the conditions in JESD22-A114-E. | | |

Note: Stresses above those listed under absolute maximum ratings may cause permanent and functional damage to the device. Exposure exceeding absolute maximum rating conditions for extended periods may affect device reliability. The part may not survive all maximums applied simultaneously.

DC Electrical Characteristics

| Parameter | Conditions | Min. | Typ/Nom | Max. | Units |
|---|---|------|---------|------|-------|
| Supply Voltage (V _{CC}) | No RF | 3.2 | 3.8 | 6.0 | V |
| | HPM, MPM, LPM with RF | 3.2 | 3.8 | 4.2 | V |
| | Ruggedness Testing | | | 4.7 | V |
| PA Enable Digital Control Voltage (V _{EN}) | Low – PA off | 0.0 | | 0.5 | V |
| | High – PA Enabled | 1.8 | | 3.0 | V |
| PA Bias Mode Control Voltages (V _{MODE1} , V _{MODE2}) | V _{MODE1} / V _{MODE2} = Low | 0.0 | | 0.5 | V |
| | V _{MODE1} / V _{MODE2} = High | 1.8 | | 3.0 | V |
| Control Line Current (I _{CONTROL}) | All control lines (source or sink current) | | 0.04 | 1 | mA |
| “Off Current” (I _{OFF}) | Total current on all pins; T=-20to+85°C, V _{CC} =4.7V, V _{EN} =0V | | 5 | 15 | µA |
| Leakage Current (I _{LEAK}) | Total current on all pins; T=-20to+85°C, V _{CC} =4.7V, V _{EN} =0V | | 5 | 15 | µA |
| Turn on/off time ¹ (T _{ON-DC} , T _{OFF-DC}) | | | 1.5 | 20 | µs |
| Gain switching time (T _{MODE}) | High-Mid-Low | | 0.7 | 6 | µs |
| Ambient Operating Temperature | | -30 | | +85 | °C |
| Case Temperature (TEMP _{CASE}) | | -35 | | +95 | °C |

*Note 1: Definition of switching time: T_{ON-DC} = The time required to obtain the idle bias condition ±10% from a zero bias condition with RF signal applied
T_{ON-RF} = The time required to go from zero output power to reach the final output power ± 1 dB.
T_{OFF-DC} = The time required for the bias current (idle current) to decrease to < 100µA
T_{OFF-RF} = The time required to for the output power to decrease 30 dB when input signal is removed.*

Tritium II PA-Duplexer Module™ CDMA PCS Band

Power Range Truth Table

| Mode of Operation | V _{EN} | V _{MODE1} | V _{MODE2} | V _{CC} |
|--|-----------------|--------------------|--------------------|-----------------|
| Power Down / PA Off | Low | X | X | ON |
| Stand-by mode N/A | N/A | N/A | N/A | N/A |
| High Power Mode – HPM (-50 dBm < P _{OUT} < +26 dBm) | High | Low | High | ON |
| Medium Power Mode – MPM (-50 dBm < P _{OUT} < +16 dBm) | High | High | High | ON |
| Low Power Mode – LPM (-50 dBm < P _{OUT} < +13 dBm) | High | X | Low | ON |

Tx to Antenna Port RF Electrical Characteristics¹

| Parameter | Conditions | Min. | Typ/Nom | Max. | Units |
|---|--|---------|---------|---------|--------|
| RF Frequency | | 1851.25 | - | 1908.75 | MHz |
| Maximum Output Power | HPM, V _{CC} =3.4 – 4.2V | 26 | - | - | dBm |
| | MPM, V _{CC} =3.4 – 4.2V | 16 | - | - | dBm |
| | LPM, V _{CC} =3.4 – 4.2V | 13 | - | - | dBm |
| Maximum Input Power | HPM | 7 | - | - | dBm |
| | MPM | 9 | - | - | dBm |
| | LPM | 9 | - | - | dBm |
| Tx Gain | HPM | 18 | 25 | 29 | dB |
| | MPM | 9 | 15 | 19 | dB |
| | LPM | 4 | 9 | 15 | dB |
| Step Function Droop ² | HPM | - | - | 0.3 | dB |
| Tx Gain in GPS Band | | - | - | -44 | dB |
| Gain Flatness | HPM | - | - | ±2.0 | dB |
| | MPM | - | - | ±1.8 | dB |
| | LPM | - | - | ±1.5 | dB |
| Tx VSWR | Tx in port | - | - | 2.5:1 | |
| Adjacent Channel Power ⁶ (EVDO RevA 4096 payload) | HPM, 3.8V, 26dBm, 25°C | - | -52 | -45 | dBc |
| | HPM, 3.4V, 25dBm, -30°C to 70°C | - | -52 | -45 | dBc |
| | MPM, 16dBm, -30°C to 70°C | - | -52 | -45 | dBc |
| | LPM, 13dBm, -30°C to 70°C | - | -52 | -45 | dBc |
| Alternate Channel Power ⁶ (EVDO RevA 4096 payload) | HPM, 3.8V, 26dBm, 25°C | - | -60 | -53 | dBc |
| | HPM, 3.4V, 25dBm, -30°C to 70°C | - | -60 | -53 | dBc |
| | MPM, 16dBm, -30°C to 70°C | - | -60 | -53 | dBc |
| | LPM, 13dBm, -30°C to 70°C | - | -60 | -53 | dBc |
| Power Efficiency | HPM, 3.4V, 25°C, 25dBm | - | 22 | - | % |
| BC1 Tx Noise in BC1 Rx Band | HPM, N _{IN} at Tx port = -135dBm/Hz | - | - | -183 | dBm/Hz |
| | MPM, N _{IN} at Tx port = -135 – (HP _{MAX} – MP _{MAX}) dBm/Hz | - | - | -183 | dBm/Hz |
| | LPM, N _{IN} at Tx port = -135 – (HP _{MAX} – LP _{MAX}) dBm/Hz | - | - | -183 | dBm/Hz |
| Tx Noise in GPS Band | N _{IN} at Ant port = -135 dBm/Hz | - | - | -174 | dBm/Hz |
| Harmonics | P _{out} = 26dBm | - | -75 | -45 | dBc |
| Stability (all spurious) | Load VSWR = 10:1 @ all angles | - | - | -90 | dBc |
| Ruggedness | HPM, Load VSWR = 10:1 @ all angles, No Damage | | 26dBm | | |
| | MPM, Load VSWR = 10:1 @ all angles, No Damage | | 16dBm | | |
| | LPM, Load VSWR = 10:1 @ all angles, No Damage | | 13dBm | | |

Data Sheet

For additional information and latest specifications, see our website: www.triquint.com

Revision H, June 21, 2010



Tritium II PA-Duplexer Module™ CDMA PCS Band

Tx to Antenna Port RF Electrical Characteristics¹ (cont.)

| Parameter | Conditions | Min. | Typ/Nom | Max. | Units |
|--|---|--------|---------|--------|-------|
| CDG Current ³ including RFT contributions | V _{CC} = 3.8V, 25°C | - | 44 | 50 | mA |
| PA Switching Time: Rise / Fall ⁴ | 0dB < P _{OUT} < 5dBm | - | 0.165 | 6.0 | µs |
| Code Domain Power ⁵ | 25°C < T < 60°C | 23 | - | - | dB |
| Code Channel Reverse Plot Power Accuracy | HPM, 5.5dBm P _{OUT} , R-FCH to R-Pilot @ 9600 rate | 3.50 | - | 4.00 | |
| | HPM, 5.5dBm P _{OUT} , R-SCH to R-Pilot @ 9600 rate | 3.50 | - | 4.00 | |
| Convolution Encoding ⁷ | HPM, 5.5dBm P _{OUT} , R-FCH to R-Pilot @ 19.2K rate | 3.38 | - | 3.88 | |
| | HPM, 5.5dBm P _{OUT} , R-SCH to R-Pilot @ 19.2K rate | 6.00 | - | 6.50 | |
| | HPM, 5.5dBm P _{OUT} , R-FCH to R-Pilot @ 38.4K rate | 2.13 | - | 2.63 | |
| | HPM, 5.5dBm P _{OUT} , R-SCH to R-Pilot @ 38.4K rate | 7.25 | - | 7.75 | |
| | HPM, 5.5dBm P _{OUT} , R-FCH to R-Pilot @ 76.8K rate | 0.88 | - | 1.38 | |
| | HPM, 5.5dBm P _{OUT} , R-SCH to R-Pilot @ 76.8K rate | 8.75 | - | 9.25 | |
| | HPM, 5.5dBm P _{OUT} , R-FCH to R-Pilot @ 153.6K rate | -1.00 | - | -0.50 | |
| | HPM, 5.5dBm P _{OUT} , R-SCH to R-Pilot @ 153.6K rate | 10.25 | - | 10.75 | |
| Code Channel Reverse Pilot Power Accuracy | HPM, 5.5dBm P _{OUT} , R-FCH to R-Pilot @ 19.2K rate | 3.250 | - | 3.750 | |
| | HPM, 5.5dBm P _{OUT} , R-SCH to R-Pilot @ 19.2K rate | 5.250 | - | 5.750 | |
| Turbo Encoding ⁷ | HPM, 5.5dBm P _{OUT} , R-FCH to R-Pilot @ 38.4K rate | 2.250 | - | 2.750 | |
| | HPM, 5.5dBm P _{OUT} , R-SCH to R-Pilot @ 38.4K rate | 6.750 | - | 7.250 | |
| | HPM, 5.5dBm P _{OUT} , R-FCH to R-Pilot @ 76.8K rate | 1.125 | - | 1.625 | |
| | HPM, 5.5dBm P _{OUT} , R-SCH to R-Pilot @ 76.8K rate | 8.250 | - | 8.750 | |
| | HPM, 5.5dBm P _{OUT} , R-FCH to R-Pilot @ 153.6K rate | -0.625 | - | -0.125 | |
| | HPM, 5.5dBm P _{OUT} , R-SCH to R-Pilot @ 153.6K rate | 9.250 | - | 9.750 | |

Note 1: Test Conditions: V_{CC1}=3.8VDC, T_C = 25°C unless otherwise specified.

Note 2: With the module in high gain mode steps the RF signal from -80dBm a level such that PO = POUT (H). The rise time for the step in the input power to the module shall not exceed 250ns

Note 3: Total current integrated across CDMA suburban CDG curve including estimated RFT contributions

Note 4: Rise: time required to go from (Pout - 30 dB) to (Pout ± 1 dB); Fall: time required to reach (Pout - 30 dB) from (Pout ± 1 dB) when input signal removed.

Note 5: To be measured at Pout = 26dBm. Refer to IS98E section 4.3.5.

Note 6: Linearity in MPM and LPM for CDMA EVDO revA modulation is guaranteed with a 1dB back-off from stated switch points

Note 7: Refer to IS-98E section 4.4.9; High Power Mode only; required to meet this specification at +25C

Rx to Antenna Port RF Electrical Characteristics

| Parameter | Conditions | Min. | Typ/Nom | Max. | Units |
|-------------------------|---|------|---------|-------|-------|
| Frequency | | 1930 | - | 1990 | MHz |
| Mid Band Insertion Loss | 1935 – 1985 MHz | - | 2.0 | 2.8 | dB |
| Insertion Loss | 1930 – 1990 MHz over temperature | - | 2.6 | 3.5 | dB |
| Rx VSWR | ANT and Rx ports | - | - | 2.5:1 | |
| Attenuation | BCO Tx 824-849 MHz | 25 | - | - | dB |
| | BC1 Tx 1850-1910 MHz | 45 | - | - | dB |
| | ISM Tx 2400-2484 MHz | 35 | - | - | dB |
| | Rx 2 nd Harmonic 3860-3980 MHz | 30 | - | - | dB |
| | Rx 3 rd Harmonic 5790-5970 Mhz | 30 | - | - | dB |
| | Rx 4 th Harmonic 7720-7960 MHz | 30 | - | - | dB |

Data Sheet

For additional information and latest specifications, see our website: www.triquint.com

Revision H, June 21, 2010



Tritium II PA-Duplexer Module™ CDMA PCS Band

Tx to Rx Port RF Electrical Characteristics

| Parameter | Conditions | Min. | Typ/Nom | Max. | Units |
|-------------------------------|---------------------------------|------|---------|-------|-------|
| Small Signal Gain | | - | - | -54 | dB |
| Tx Leakage | 25.5 dBm, 3.8V, 25°C < T < 60°C | - | -31 | -26.1 | dBm |
| Triple Beat Test ¹ | T = 25°C, Center Band | | -91 | | dB |

Note 1: Ratio of CW jammer to triple beat product at Rx port (HPM only). Triple beat frequencies: Ant input = 1930, 1960, 1990 MHz; Tone 1 = 1850, 1880, 1910MHz; Tone 2 = 1851, 1881, 1931 MHz

Coupled Port RF Electrical Characteristics

| Parameter | Conditions | Min. | Typ/Nom | Max. | Units |
|--------------------------|--|------|---------|-------|-------|
| Tx Power at Coupled Port | Over freq & temp relative to P _{OUT} , 15dBm < P _{OUT} < 26dBm | -23 | - | -18 | dBc |
| Output Impedance | | - | 50 | - | Ω |
| VSWR | HPM, Coupled Port | - | - | 2.0:1 | |
| Directivity Error | HPM, 3.5:1 @ all angles, 22dBm < P _{OUT} < 26dBm | -4.0 | - | 1.0 | dB |
| Temp Variation | HPM, 25dBm, 50Ω load at ANT, 3.8V, -30°C < T < 85°C | -0.5 | - | 0.5 | dB |

Tritium II PA-Duplexer Module™ CDMA PCS Band

Pin Out and Assignments

TOP VIEW (through package)

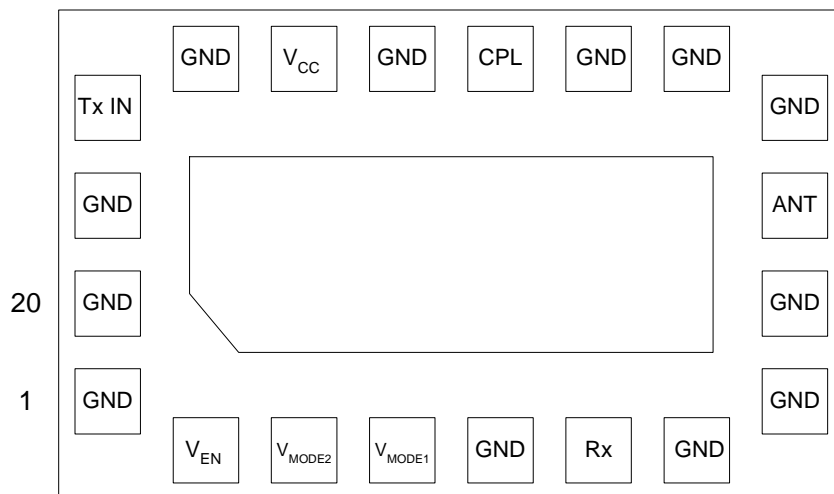

| Pin | Symbol | Description |
|-----|--------------------|---|
| 1 | GND | Ground |
| 2 | V _{EN} | Enable Logic Control |
| 3 | V _{MODE2} | Control for low power mode |
| 4 | V _{MODE1} | Control for high and medium power modes |
| 5 | GND | Ground |
| 6 | Rx | Duplexer Rx Output Port |
| 7 | GND | Ground |
| 8 | GND | Ground |
| 9 | GND | Ground |
| 10 | ANT | Duplexer Antenna Port |
| 11 | GND | Ground |
| 12 | GND | Ground |
| 13 | GND | Ground |
| 14 | CPL | Directional Coupler Output Port |
| 15 | GND | Ground |
| 16 | V _{CC} | PA Power Supply |
| 17 | GND | Ground |
| 18 | Tx _{in} | Tx Input |
| 19 | GND | Ground |
| 20 | GND | Ground |

Tritium II PA-Duplexer Module™ CDMA PCS Band

Applications information; tuning procedures; board layout precautions

TriQuint offers our customers the below evaluation board as a means for testing and analysis of the TQM663029A. The evaluation board schematic and picture are provided for preliminary analysis and design. The following figures show the TriQuint application board and the schematic of the board followed by the power-up/power-down sequence instructions

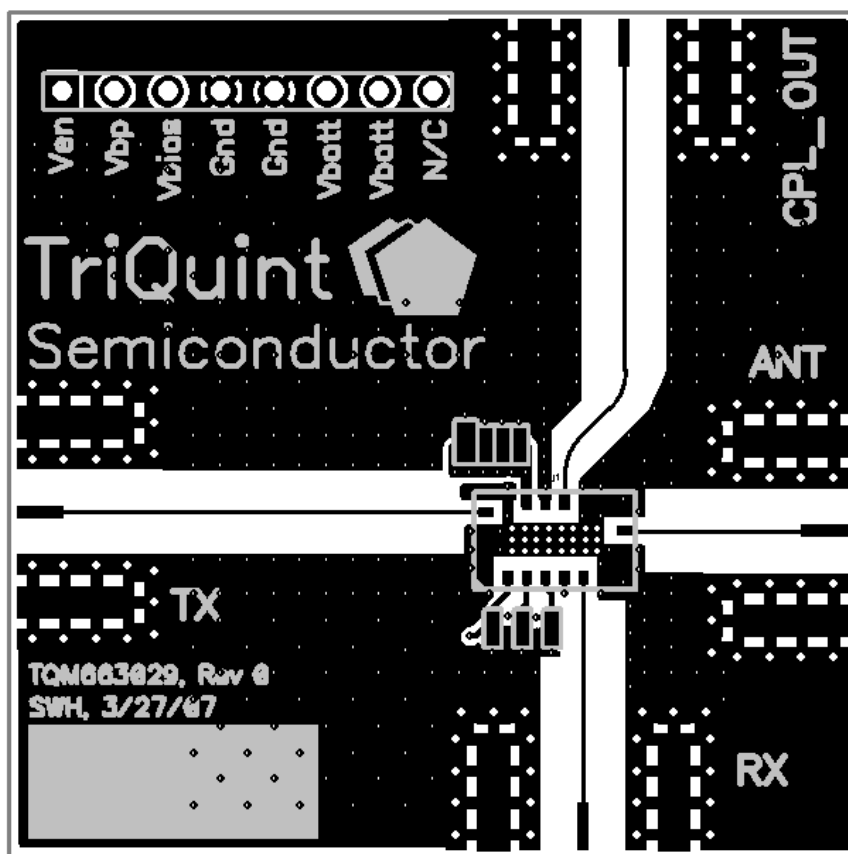

Tritium II PA-Duplexer Module™ CDMA PCS Band

PC Board Layout recommendations

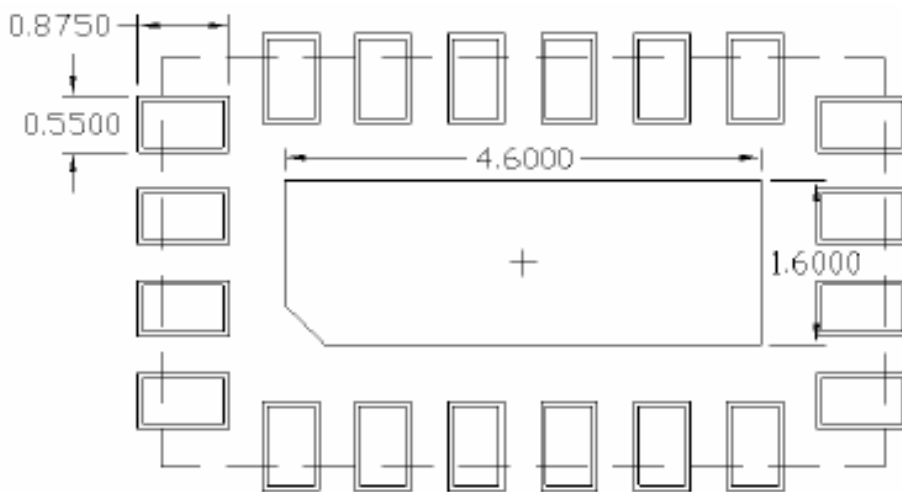
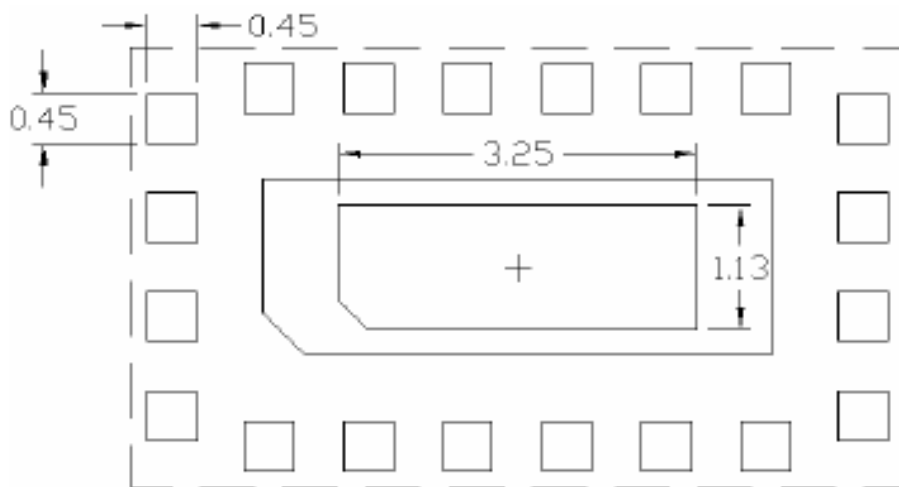

Recommended Reflow Profile

Data Sheet

For additional information and latest specifications, see our website: www.triquint.com
Revision H, June 21, 2010



Tritium II PA-Duplexer Module™ CDMA PCS Band

The TQM663029A is rated for 260°C reflow profile. Below is a general recommendation for 260°C reflow. The specific profile used will need to take into account the requirements of the board, other components, and the layout. The following recommendation should only be used as a guideline.

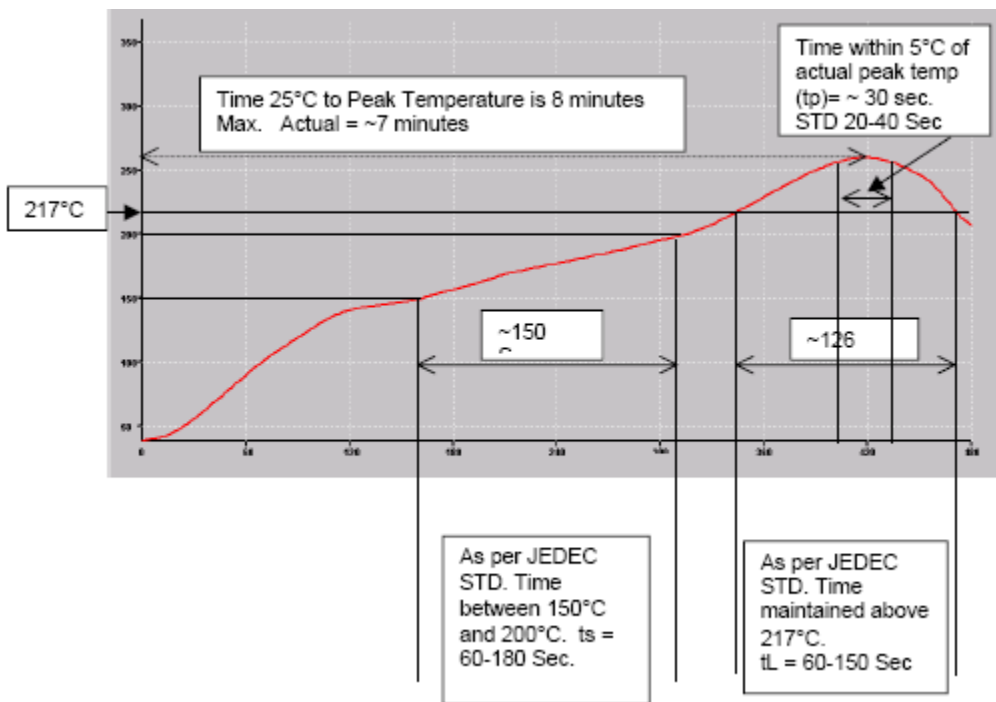

Tritium II PA-Duplexer Module™ CDMA PCS Band

Package Marking



4x7mm, Pin 1 Lower Left Hand Corner

- 1) Line 1: TriQuint + Logo
- 2) Line 2: Product Name: TQM663029A
- 3) Line 3: YYWW = Year/Week [CCCC = Country Code (Production Parts), Engineering Mark (Must start w/ letter "E", ENGR (Default) E#@# (Engineering Revision with 3 Digits, where # = number, @ = letter), ES#@ (Engineering revision with 2 digits, where # = number, @ = letter))]
- 4) Line 4: XXXXXXXX (6 to 8 character alphanumeric lot number)

Tape and Reel Specification:

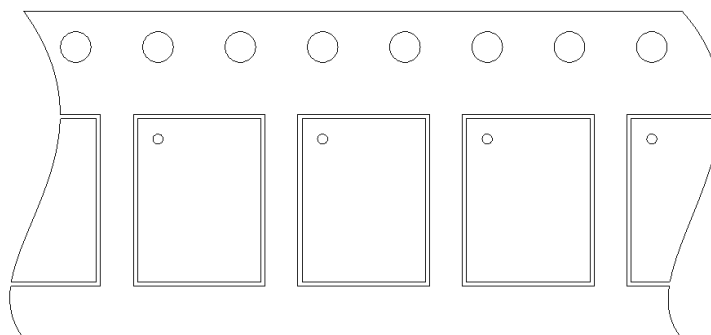

MODULE 4x7 and 5x8
User Direction of Feed →

Carrier tape - 3M part # 3M053091, Ao = 4.55mm, Bo = 7.60mm, Ko = 1.73mm, width = 16mm, pitch = 8mm
Cover tape - 3M part # 2678 13.3mm wide

Note: Packaged quantity is 2,500 per reel

Shipment Box & Label Description:

Data Sheet

For additional information and latest specifications, see our website: www.triquint.com
Revision H, June 21, 2010









Tritium II PA-Duplexer Module™ CDMA PCS Band

Tape & Reels will be packaged in a dry-pack bag and then in a shipment box. The box dimensions will depend on the number of reels shipped in each box and are noted in the table below. The box label and a description of each item on the label are also shown below.

| 13 Inch x16mm--Drypack | | |
|------------------------|--------------|-------------------------|
| Box Size | Reel Qty/Box | Empty Box Wt w/ Packing |
| 15x15x7 | 3 | 2 |
| 18x15x11 | 5 | 2.36 |
| 17x16x17 | 9 | 2.76 |



| | | |
|---|---|--|
| Format: 4 * 6.5 in 102 * 166 mm Code 39 1:2 | Ship From: TRIQUINT SEMICONDUCTOR, INC 2300 NE BROOKWOOD PARKWAY HILLSBORO, OR 97124 | Ship To: Recipient Address Information Here |
| Supplier Code: 10 Character Max. + TQS Shipper Number. (Pkg. ID/Serial Number) | (3S) Pkg ID: 581+23047123  | |
| Customer Purchase Order. 20 Character Max. | (K) Trans ID: 812934657  | |
| Customer Part Number. 22 Character Max. | (P) CPN: 5871-2489  | |
| Quantity. | (Q) QTY: 20000  | |
| Supplier Product Number. 21 Character Max. | (1P) SPN: TQD777001  | |
| Box Count (1/3, 2/3, etc.) | (13Q) Pkg Count: 1/1  | |
| | Package Weight 3.0 LB / 1.36 KG | |

All Barcodes Contain
Data Identifier Followed
by Data, e.g.
K812934657

Manufacturer's
Part Number

Tritium II PA-Duplexer Module™ CDMA PCS Band

Additional Information¹

This part is compliant with RoHS directive (Restrictions on the Use of Certain Hazardous Substances in Electrical and Electronic Equipment).

The part is rated Moisture Sensitivity Level 3 at 260°C per JEDEC standard IPC/JEDEC J-STD-020.

¹ For latest specifications, additional product information, worldwide sales and distribution locations, and information about TriQuint:

Web: www.triquint.com

Tel: (503) 615-9000

Email: info_wireless@tqs.com

Fax: (503) 615-8902

For technical questions and additional information on specific applications:

Email: info_wireless@tqs.com

The information provided herein is believed to be reliable; TriQuint assumes no liability for inaccuracies or omissions. TriQuint assumes no responsibility for the use of this information, and all such information shall be entirely at the user's own risk. Prices and specifications are subject to change without notice. No patent rights or licenses to any of the circuits described herein are implied or granted to any third party.

TriQuint does not authorize or warrant any TriQuint product for use in life-support devices and/or systems.

Copyright © 2004 TriQuint Semiconductor, Inc. All rights reserved 2008.

Data Sheet

For additional information and latest specifications, see our website: www.triquint.com

Revision H, June 21, 2010

