

## Non-isolation High Power Factor LED Driver

### Features

- Transition mode (TM) PFC control
- Non-isolation flyback topology
- Precision current regulation for LED
- Cycle-by-cycle over current protection
- VCC pin over voltage protection
- Output open protection
- Constant on time PWM control
- Programmable CT pin for PFC optimization

### Application

- LED lighting

### General Description

The GL8216 is a high performance non-isolation AC/DC off-line switching mode single stage PFC control IC for LED lighting. It's built-in an accuracy +/- 1% reference voltage for current regulation. The feedback control loop is easily compensated by connected a capacitor to COMP pin and ground. The application circuit for constant current is very simple without any OPamp required. It's suitable for low cost LED driver with PFC requirement and accuracy LED current.

### Ordering and Marking Information

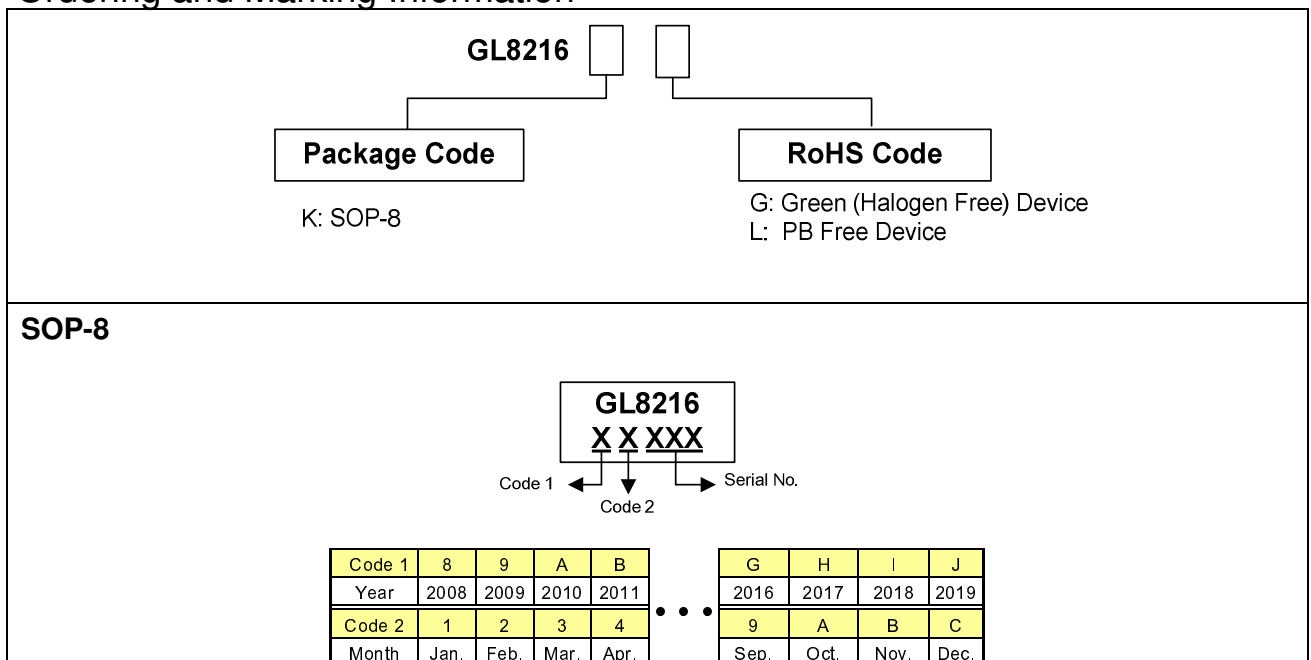

Grenergy OPTO Inc. reserves the right to make changes to improve reliability or manufacture ability without notice, and advise customers to obtain the latest version of relevant information to verify before placing orders.

## Pin Configuration

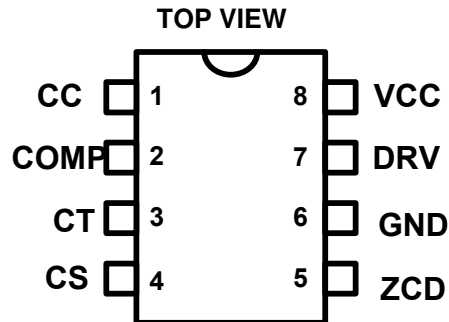

## Pin Description

Pin No.	Name	Function
1	CC	The Constant Current pin is connected to the internal error amplifier.
2	COMP	The COMP pin is connected to the output of internal error amplifier. Adding compensation network to stabilize the control loop and get higher power factor.
3	CT	The CT pin is connected to the current source to charge the external capacitor and compare the COMP voltage to terminate the power switch.
4	CS	The Current Sense pin is connected to the input of OCP comparator, and terminates the power switch when the current sense voltage is beyond threshold.
5	ZCD	The Zero Current Detector Input, which is connected to an auxiliary winding to monitor the zero crossing current of the inductor. When the ZCD detects that the winding has been demagnetized, it will send the set signal to turn on the external MOSFET.
6	GND	The ground pin.
7	DRV	The DRV pin is connected to the totem pole gate driver to drive the external power switch.
8	VCC	Positive power supply pin.

### Absolute Maximum Ratings

Supply voltage VCC .....	30V
Junction temperature .....	150°C
Operating ambient temperature .....	-20°C ~ 85°C
Storage temperature range .....	-65°C ~ 150°C
SOP-8 package thermal resistance .....	160°C/W
Power dissipation (SOP-8, at ambient temperature = 85°C) .....	400mW
Lead temperature (All Pb free packages, soldering, 10sec) .....	260°C
ESD voltage protection, human body model .....	2KV
ESD voltage protection, machine model .....	200V

### Block Diagram

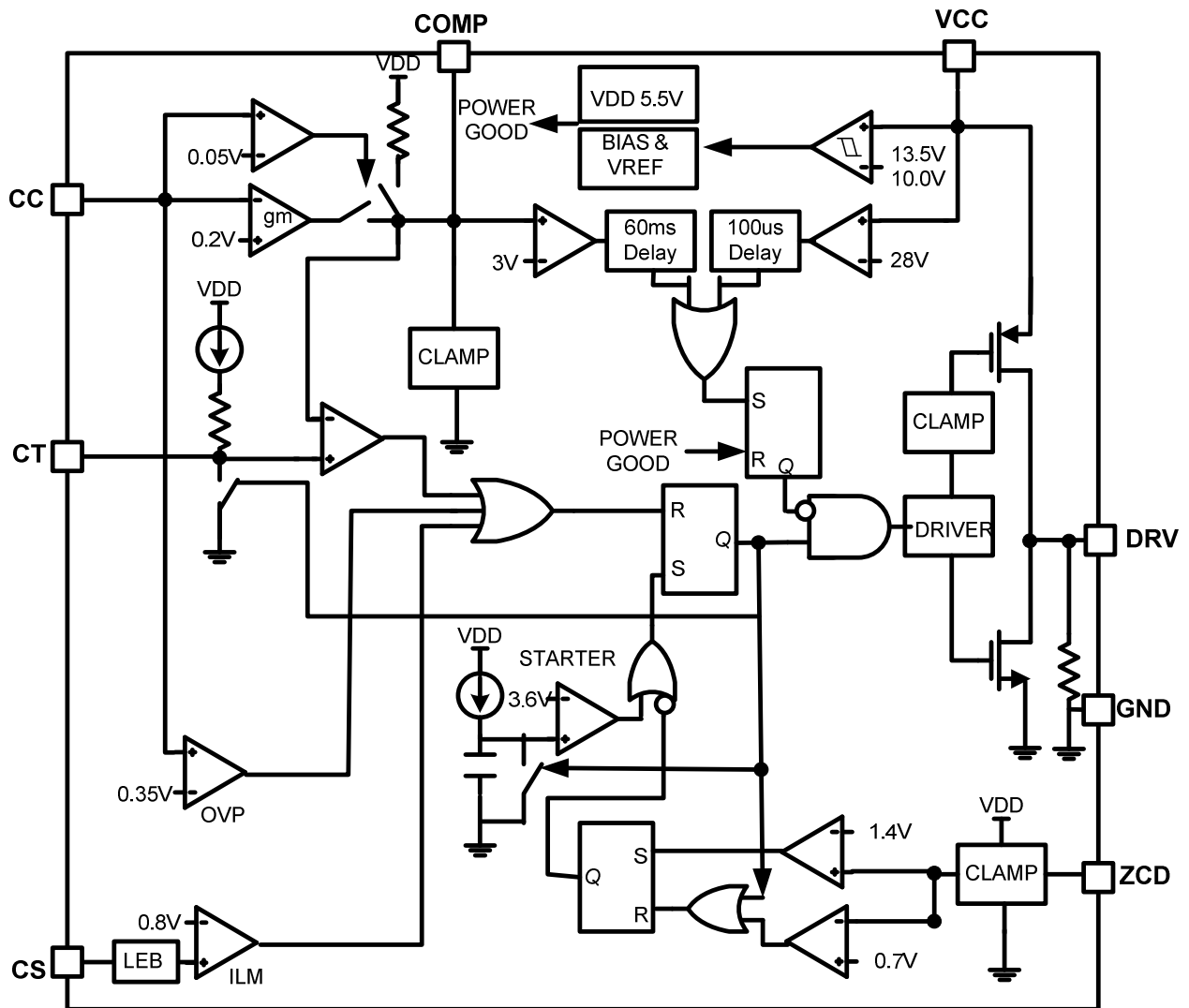

Electrical Characteristics ( $V_{CC} = 15V$ ,  $T_A = 25^\circ C$ , unless otherwise specified.)

Parameter	Symbol	Test Conditions	Min	Typ	Max	Units
-----------	--------	-----------------	-----	-----	-----	-------

**SUPPLY SECTION**

VCC turn-on threshold (UVLO on)	$UVLO_{ON}$		12.5	13.5	14.5	V
VCC turn-off threshold (UVLO off)	$UVLO_{OFF}$		9	10	11	V
VCC UVLO on/off hysteresis	$UVLO_{HYST}$			3.5		V
Operation current	$I_{VCC}$	$C_{LOAD} = 1nF, f_{sw}=70kHz$		2.5	3.2	mA
		$C_{LOAD} = 0F, f_{sw}=70kHz$		1.6	2.5	mA
Startup current	$I_{VCCSTART}$	$V_{CC} = UVLO_{ON} - 0.5V$		21	50	uA
VCC over voltage protection	$V_{CCOVP}$		26	28	30	V

**ZERO CURRENT DETECTOR SECTION**

Upper clamp voltage	$V_{ZCDH}$	$I_{ZCD} = 2.5mA$	4.3	4.8	5.3	V
Lower clamp voltage	$V_{ZCDL}$	$I_{ZCD} = -2.5mA$	-0.4	-0.2	0	V
Arming voltage (positive-going edge)	$V_{ZCDA}$		1.2	1.4	1.6	V
Arming voltage (negative-going edge)	$V_{ZCDT}$		0.5	0.7	0.9	V
Input bias current	$V_{ZCDB}$		1	1.5	2	uA

**PROTECTION SENSE SECTION**

Over load protection Vcomp threshold	$V_{OLP}$		2.6	3.0		v
Output over voltage protection	$V_{OVP}$			0.35		v

**INTERNAL VOLTAGE REFERENCE SECTION**

Reference voltage	$V_{REF}$	$T_A = 25^\circ C$	198	200	202	mV
Line regulation	$\Delta V_{REG}$	$13V < V_{CC} < 20V$		2	5	mV
Temp. stability	$T_{STAB}$	$-40^\circ C \leq T_{AMB} \leq 125^\circ C$		0.5	1	%
Total variation	$\Delta V_{TOT}$	Over VCC and Tj ranges		2.5		mV

**VOLTAGE ERROR AMPLIFIER SECTION**

Transconductance	$g_m$	$V_{in}=0.1$ to $0.3V$	100	120	140	uS
Source current	$I_{SOURCE}$	$CC=0.1V$	-10	-12	-14	uA
Sink current	$I_{SINK}$	$CC=0.3V$	10	12	14	uA
Effective $V_{COMP}$ voltage	$V_{COMP\ EFF}$		3.2	3.5	3.8	V
Input bias current	$I_{IB}$	$CC= 0.2V$ $-25^\circ C \leq T_{AMB} \leq 125^\circ C$	-0.25		-1.25	uA
Sourcing current	$I_{COMP}$	$CC=0V$	-0.5	-1	-2	mA

**CURRENT LIMIT SECTION**

Peak current limit protection ( $I_{PKLMT}$ ) $I_{SNS}$ voltage threshold	$V_{ISNS}$		0.7	0.8	0.9	V
Leading edge blanking time	$t_{LEB}$		350	450	550	ns
Delay to output	$t_{TD}$			130	220	ns

**GATE DRIVER SECTION**

Output low level	$V_{OL}$	$I_o = 20mA$			1	V
Output high level	$V_{OH}$	$I_o = -20mA$	8			V
Rising Time	$t_r$	$C_{LOAD} = 1nF, V_{CC} = 15V$		280	500	ns
Falling Time	$t_f$	$C_{LOAD} = 1nF, V_{CC} = 15V$		80	150	ns
Gate clamp voltage	$V_{DRV}$	$V_{CC} = 20V$	10		15	V

**RAMP CONTROL SECTION**

CT charge current	$I_{CT}$	$V_{CT} = 0V$	-80	-100	-120	$\mu A$
Start timer period	$t_{ST}$		75	160	300	$\mu s$

## Typical Performance Characteristics

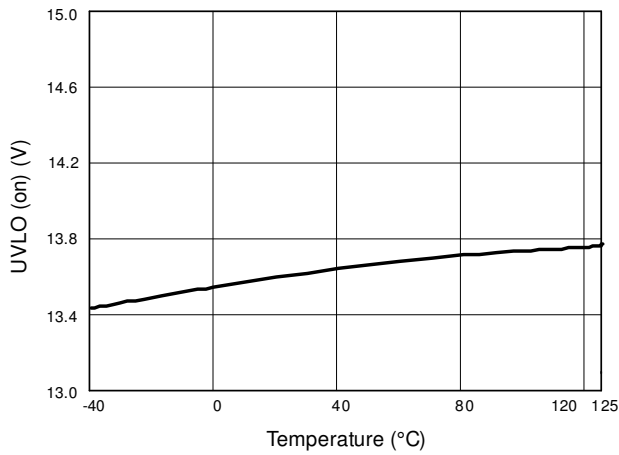

Fig. 1 UVLO (on) vs. Temperature

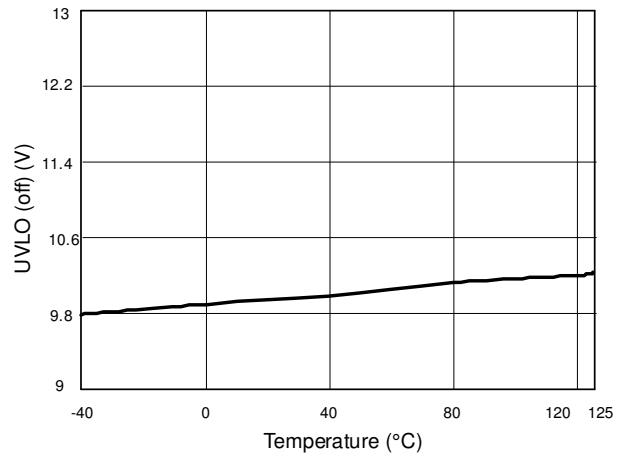

Fig. 2 UVLO (off) vs. Temperature

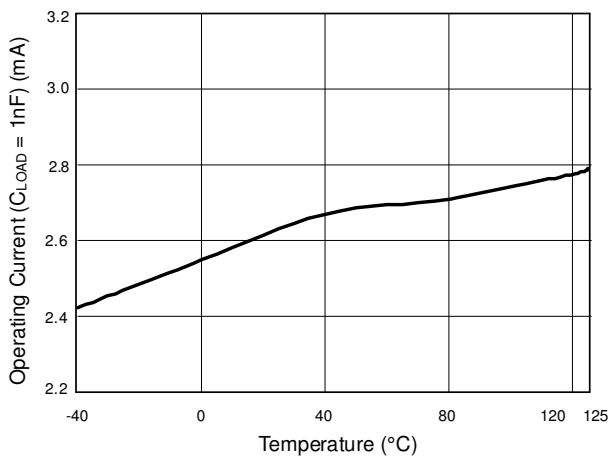
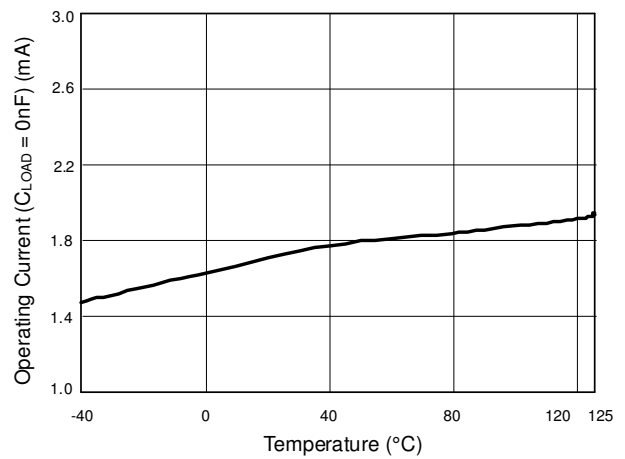
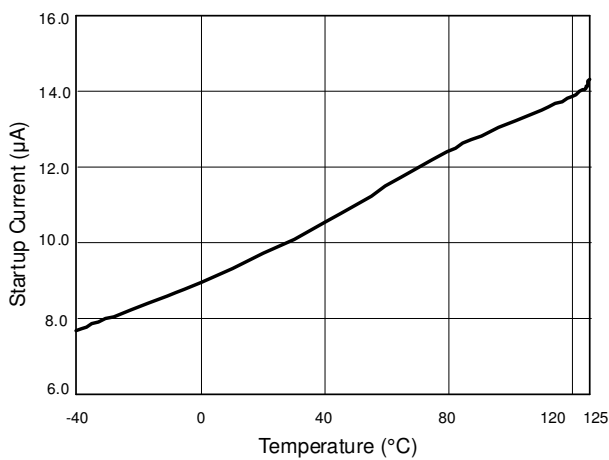

 Fig. 3 Operating Current (C<sub>LOAD</sub> = 1nF) vs. Temperature

 Fig. 4 Operating Current (C<sub>LOAD</sub> = 0nF) vs. Temperature

Fig. 5 Startup Current vs. Temperature

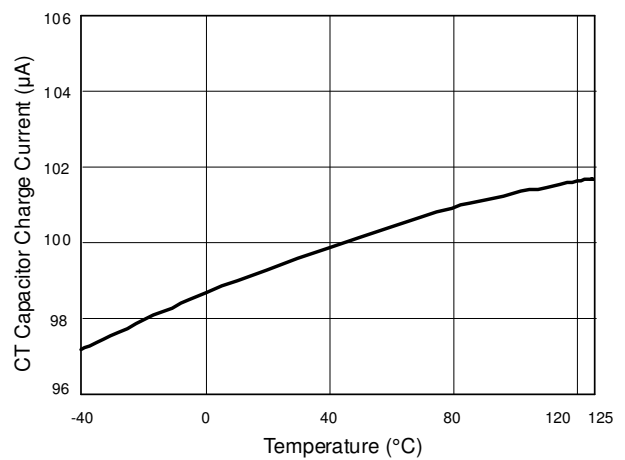

Fig. 6 CT Capacitor Charge Current vs. Temperature

## Typical Performance Characteristics(Cont.)

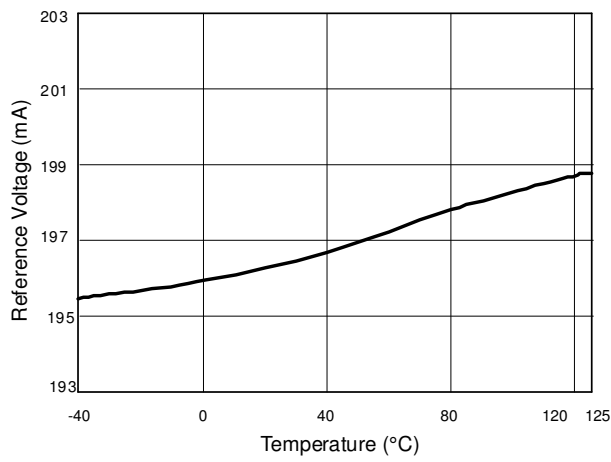

Fig. 7 Reference Voltage vs. Temperature

## Application Information

### Overview

The GL8216 contains a programmable timer, a transconductance error amplifier used in a feedback loop, an over current comparator, a current sense comparator, a zero current detector, a PWM and logic circuit, a totem pole MOSFET driver, an internal voltage reference, a restart timer and under voltage lockout circuit. It achieves the PFC function by using constant on time and voltage mode control.

### Constant On time

The on time of pulse width to drive MOSFET is determined by the input CT pin and the error amplifier output COMP pin. The input CT pin provides the saw tooth waveform to compare with the COMP pin signal. The driver turned off when CT pin voltage reaches to COMP pin voltage. Due to the boundary mode operation of the transformer, the PFC function is implemented naturally by constant on time mode control.

### Transconductance Error Amplifier

With an external capacitor between the pins COMP and GND, the transconductance error amplifier forms an active low pass filter. The low pass filter monitors the average output current over several line cycles. Typically the filter's bandwidth is set below 10Hz in order to suppress the 100Hz line ripple of the output current. The non-inverting input is biased internally at an accuracy reference voltage 0.2V. The inverting input CC pin is directly connected to the sense resistor series with LED. The gate drive is disabled when CC voltage is more than 0.35V.

### Over current Comparator

Because of the feedback loop with low bandwidth, the fast changes of the output current can't be

regulated within an adequate time. Fast output changes occur during initial start-up. During this fast changes, a peak current is flowing through the external sense resistor series to LED. If this current exceeds an internal defined margin the over current comparator shut down the gate driver to reduce the output current.

### Current Sense Comparator

An external sense resistor connected to the MOSFET source and ground transfers the source current of the MOSFET into a sense voltage. The signal is compared with internal reference voltage 0.8V. The switch-on peak current of the MOSFET is blanked out via a leading edge blanking circuit with a blanking time of typically 450ns.

### Zero Current Detector

The zero current detector senses the inductor current via an auxiliary winding and ensures that the next on-time of the MOSFET is initiated immediately when the inductor current has reached zero. This diminishes the reverse recovery losses of the flyback converter diode. The MOSFET is switched off when the voltage of the CT pin reaches the voltage level of the error amplifier output. So the inductor current waveform has a triangular shape and there are no dead-time gaps between the cycles. This leads to an AC line current proportional to line voltage. To prevent false tripping the zero current detector is designed as a Schmitt-Trigger with a hysteresis of 0.7V. An internal 4.8V clamp protects the input from overvoltage breakdown. An external resistor has to be used in series with the auxiliary winding to limit the current through the clamps.



## Restart Timer

The restart timer function eliminates the need of a oscillator. The timer starts or restarts the GL8216 when the drive output has been off for more than 160us after the inductor current reaches zero.

## Under-voltage Lockout

An under voltage lockout circuit switches the IC on

when Vcc reaches the UVLO(ON) threshold and switches the IC off when Vcc is falling below the UVLO(OFF) threshold. During star up the supply current is less than 50uA. An internal voltage clamp has been added to protect the IC from Vcc overvoltage.

## Typical Application Circuit

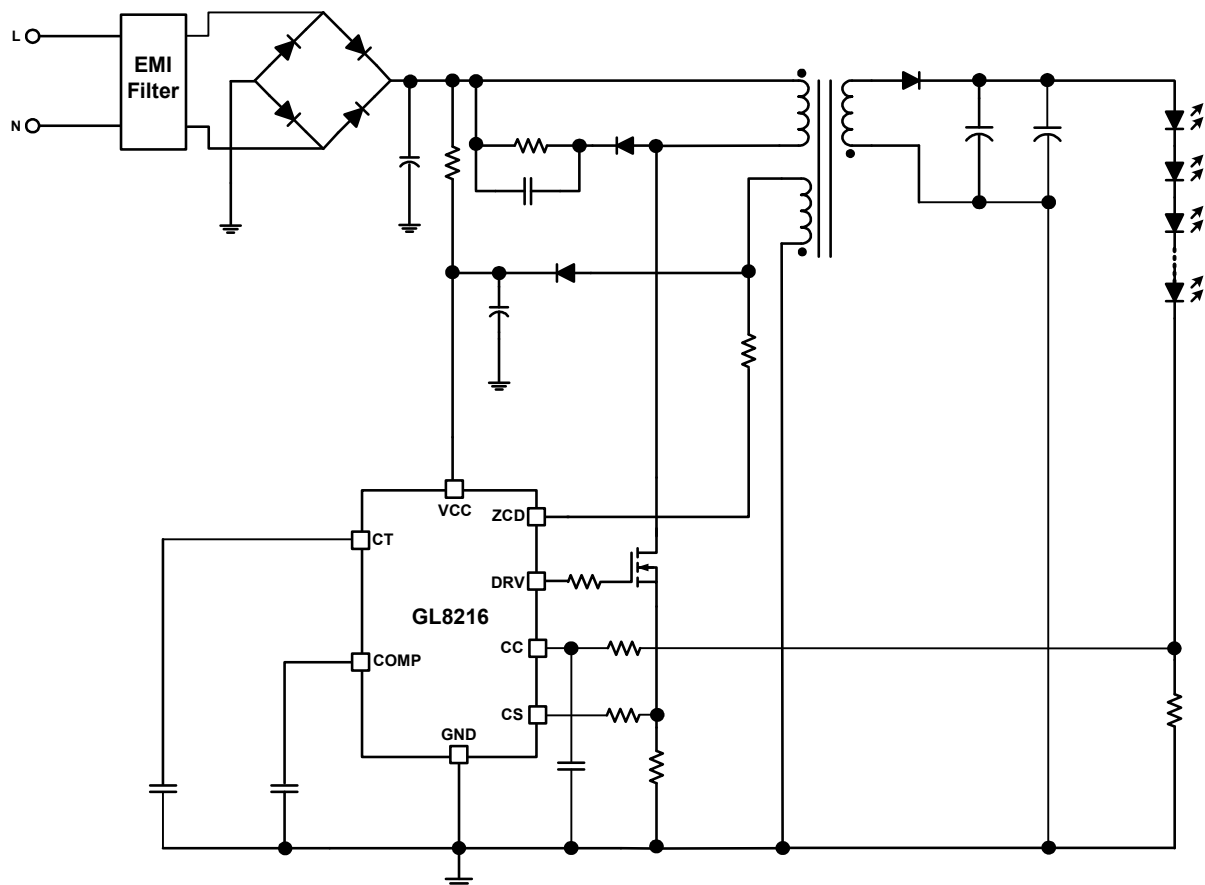

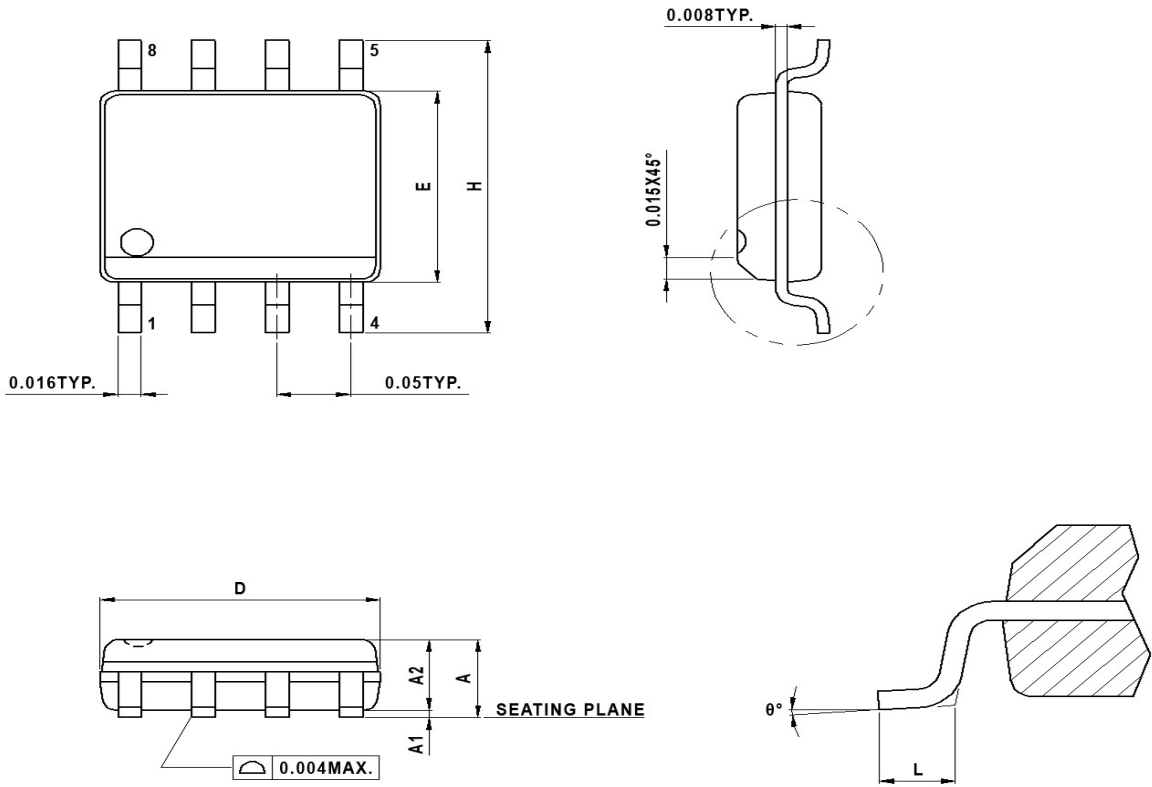
**Package Information**
**SOP-8**

SYMBOL	INCHES	
	MIN.	MAX.
A	0.057	0.069
A1	0.004	0.010
A2	0.053	0.059
D	0.189	0.196
E	0.150	0.157
H	0.228	0.244
L	0.016	0.050
$\theta^\circ$	0	8

## Carrier Tape & Reel Dimensions

SOP- 8

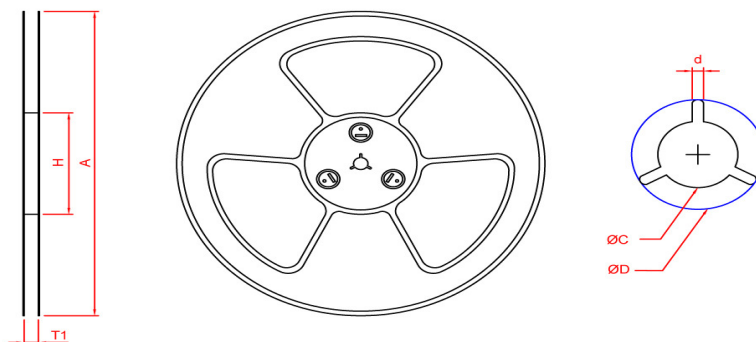
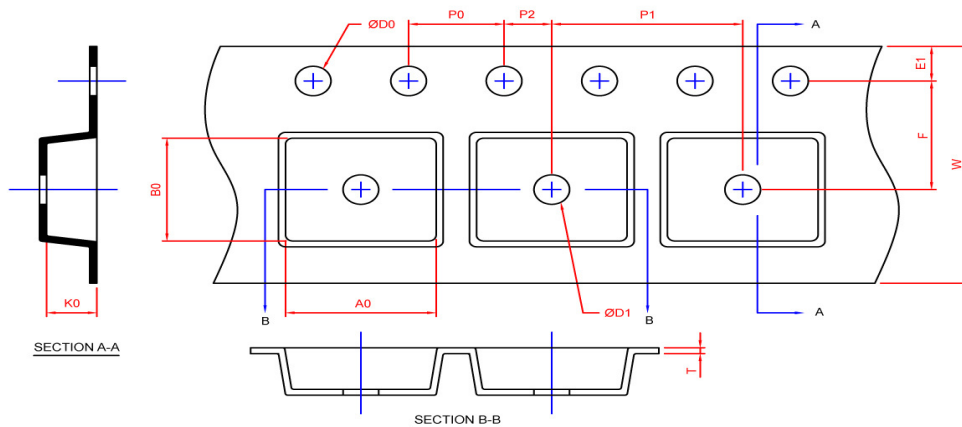

Application	A	H	T1	C	d	D	W	E1	F
SOP-8	330.0±2.0	50 MIN.	12.4+2.00 -0.00	13.0+0.50 -0.20	1.5 MIN.	20.2 MIN.	12.0±0.30	1.75±0.10	5.5±0.05
	P0	P1	P2	D0	D1	T	A0	B0	K0
	4.0±0.10	8.0±0.10	2.0±0.05	1.5+0.10 -0.00	1.5 MIN.	0.6+0.00 -0.40	6.40±0.20	5.20±0.20	2.10±0.20

(mm)

### Devices Per Unit

Application	Carrier Width	Cover Tape Width	Devices Per Reel
SOP- 8	12	-	2500

Greenergy OPTO, Inc. reserves the right to make corrections, modifications, enhancements, improvements, and other changes to its products and services at any time and to discontinue any product or service without notice. Customers should obtain the latest relevant information before placing orders and should verify that such information is current and complete.