

**HYBRID-HIGH RELIABILITY
RADIATION HARDENED
DC-DC CONVERTER**

**LSO SERIES
28V Input, Single/Dual Output**



Description

The LSO Series of DC-DC converters are, high reliability devices designed for hostile radiation hardened environments. The design is based on the heritage-rich LS Series with enhanced functional performance and an inclusion of an output overvoltage protection. The LSO Series provide up to 30 watts output power, small size, low weight, integrated EMI filtering and a high tolerance to environmental stresses such as radiation, temperature extremes, mechanical shock, and vibration. All components are fully de-rated to meet the requirements of MIL-STD-1547, MIL-STD-975 and NASA EEE-INST-002. Extensive documentation including, thermal analysis, stress analysis and reliability predictions are available.

The LSO Series of converters incorporate a fixed frequency single forward topology with magnetic feedback and an internal EMI filter. These converters are capable of meeting the conducted emissions requirements of MIL-STD-461C without any additional components. All models include an external inhibit port and have an adjustable output voltage. The converters are overload, short circuit and output over-voltage protected. They are enclosed in a hermetic 3.5" x 2.5" x 0.475" H steel package and weigh less than 125 grams. The package utilizes rugged ceramic feed-through copper core pins and is sealed using parallel seam welding.

Manufactured in a facility fully qualified to MIL-PRF-38534, these converters are fabricated utilizing DLA qualified processes. For available screening options, refer to device screening table in the data sheet.

Variations in electrical specifications and screening to meet custom requirements can be accommodated.

Features

- 18 to 40V DC Input Range
- Total Ionization Dose > 100K Rad(Si)
- SEE Hardened to LET (Heavy Ions) up to 82 MeV·cm²/mg (SEU, SEL, SEGB, SEGR)
- Internal EMI filter; Converter Capable of meeting MIL-STD-461C CE03
- Derated per MIL-STD-1547, MIL-STD-975 and NASA EEE-INST-002
- Magnetically Coupled Feedback
- Up to 30W Output Power
- Single and Dual Output Models Include 1.5, 1.8, 2.5, 3.3, 5, 12, 15, ±5, ±12 and ±15V
- Remote Sense Compensation for Single Output
- Latch-off Output Overvoltage Protection
- Input Current Telemetry
- Input Undervoltage Lockout with Latching Mode Options
- High Efficiency - to 81%
- 20MΩ @ 100VDC Isolation
- Undervoltage Protection
- Short Circuit and Overload Protection
- Adjustable Output Voltage
- Adjustable External OVP-115% to 125%
- External Inhibit
- Low Weight, < 125 grams
- 4000000 Hour MTBF (SF)

Applications

- Geo Synchronous Satellite
- Low Earth Orbit
- Deep Space Probe
- Communication and Display Systems
- Payload and Experiment LVPS

LSO SERIES

28V Input, Single/Dual Output

International
IR Rectifier

Circuit Description

The LSO Series converters utilize a single-ended forward topology with resonant reset. The nominal switching frequency is 500KHz. Electrical isolation and tight output regulation are achieved through the use of a magnetically coupled feedback. Voltage feed-forward with duty factor limiting provides high line rejection.

An internal EMI filter allows the converter to meet the conducted emissions requirements of MIL-STD-461C on the input power leads.

Functional Notes

Input Current Telemetry: The LSO Series single and dual output models also feature an input current telemetry with a magnitude of 0 to 3.3V full scale. The voltage signal at this pin (Pin 7) with respect to Output Return (Pin 12) is equal to 1.5 times the input current ($V_{in\ TLM} (V) = 1.5 * Input\ Current (A) \pm 0.1V$)

Short Circuit and Overload Protection: Output current is limited under any load fault condition to approximately 125% of rated. An overload condition causes the converter output voltage to drop below nominal. The converter will resume normal operation when the load current is reduced below the current limit point. This protects the converter from both overload and short circuit conditions. The current limit point exhibits a slightly negative temperature coefficient to reduce the possibility of thermal runaway.

Input Undervoltage Lockout (UVLO) and

Undervoltage Release (UVR): The converter is designed to be protected against an undervoltage condition. The converter will be in a non-functional (UVLO) mode when the input voltage is approximately 15.5V or less. The converter will turn on when the input voltage rises to 15.5V to 17.9V (defined as UVR threshold) and will provide a regulated output as the input voltage reaches 18V.

Should the input voltage drops below 16.5V to 14.5V (defined as UVLO threshold), the converter will turn off and remains off so long as the input voltage remains under the UVLO threshold. The converter will resume a normal operation when the input line rises above the UVR threshold. However, the converter can be configured to remain in a latch-up mode if desired.

To take advantage of the latch-up feature, the U/V Latch Pin (Pin 5) should be shorted (with less than 100 ohms) to the Inhibit Return Pin (Pin 4). Note that in this mode the converter will latch off if an undervoltage condition lasts more than 1milli-sec. The converter is reset by a shorted Enable Input pin command followed by an open Enable Input pin command.

Output Overvoltage Protection: The converter also features an output over-voltage protection. One OVP circuitry for each output for the dual output models. In an event the voltage output exceeds a preset voltage threshold of approximately 120 +/- 5% of nominal voltage output, the converter will turn off. The input power to the converter or the signal at the Inhibit pin must be recycled (connecting and removing the Inhibit pin to/from Inhibit Return pin) to turn on the converter. This event is possible only if the converter shuts off due to a false triggering. The OVP threshold voltage can also be reset to within 115% to 125% of nominal output voltage with two external resistors. Refer to the Application Notes section of the data sheet on page 9.

Inhibit (On/Off Command) : An external inhibit port is provided to control converter operation. The converter's operation is inhibited when this pin is pulled low. It is intended to be driven by an open collector logic device. The pin may be left open for normal operation and has a nominal open circuit voltage of 4V with respect to the inhibit return (Pin 4).

Output Voltage Adjustment: The output voltage of all models can be adjusted greater or less than the nominal output voltage using a single external resistor. Refer to the Application Notes section of the data sheet on page 9.

Design Methodology

The LSO Series was developed using a proven conservative design methodology derived from other space level designs that includes selection of established reliability components and fully derating to the requirements of MIL-STD-1547, MIL-PRF-975 and NASA EEE-INST-002 except for the CDR type ceramic capacitors, a capacitor with 50V rating is used for in-circuit voltage stress of less than 10V. A magnetic feedback circuit is utilized instead of opto-couplers to minimize temperature, aging and radiation sensitivity. PSPICE was used extensively to predict and optimize circuit performance for both beginning and end-of-life. Thorough design analyses include stress, thermal, and reliability (MTBF).

LSO SERIES

28V Input, Single/Dual Output



Absolute Maximum Ratings		Recommended Operating Conditions	
Input voltage range	-0.5Vdc to +60Vdc	Input voltage range ¹	+18Vdc to +40Vdc
Output power	Internally limited	Output power	0 to Max. Rated
Lead temperature	+300°C for 10 seconds	Operating case temperature	-55°C to +85°C
Operating case temperature	-55°C to +125°C (Note 13)	Operating case temperature	-55°C to +70°C
Storage temperature	-55°C to +135°C		

1. Meets MIL-STD-1547, MIL-STD-975 and NASA EEE-INST-002 up to the input voltage at 38.6V.

Electrical Performance Characteristics

Parameter	Group A Subgroup	Conditions -55°C ≤ T _C ≤ +85°C V _{IN} = 28V DC ± 5%, C _L = 0 unless otherwise specified	Limits			Unit	
			Min	Nom	Max		
Input Voltage			18	28	40	V	
Output Voltage (V _{OUT})							
LSO2801R5S	1	I _{OUT} = 100% rated load Note 4	1.47	1.50	1.53	V	
LSO2801R8S	1		1.77	1.80	1.83		
LSO2802R5S	1		2.47	2.50	2.53		
LSO2803R3S	1		3.27	3.30	3.33		
LSO2805S	1		4.95	5.00	5.05		
LSO2812S	1		11.88	12.00	12.12		
LSO2815S	1		14.85	15.00	15.15		
LSO2805D	1		±4.95	±5.00	±5.05		
LSO2812D	1		±11.88	±12.00	±12.12		
LSO2815D	1		±14.85	±15.00	±15.15		
LSO2801R5S	2,3	I _{OUT} = 100% rated load Notes 4, 13	1.43		1.57	V	
LSO2801R8S	2,3		1.73		1.87		
LSO2802R5S	2,3		2.43		2.57		
LSO2803R3S	2,3		3.23		3.37		
LSO2805S	2,3		4.90		5.10		
LSO2812S	2,3		11.76		12.24		
LSO2815S	2,3		14.70		15.30		
LSO2805D	2,3		±4.90		±5.10		
LSO2812D	2,3		±11.76		±12.24		
LSO2815D	2,3		±14.70		±15.30		
Output power (P _{OUT})							
LSO2801R5S	1,2,3	V _{IN} = 18, 28, 40 Volts, Note 2	0		12	W	
LSO2801R8S			0		14.4		
LSO2802R5S			0		20		
LSO2803R3S			0		25		
All Others			0		30		
Output current (I _{OUT})							
LSO2801R5S	1,2,3	V _{IN} = 18, 28, 40 Volts, Note 2	0		8.0	A	
LSO2801R8S			0		8.0		
LSO2802R5S			0		8.0		
LSO2803R3S			0		7.57		
LSO2805S			0		6.0		
LSO2812S			0		2.5		
LSO2815S			0		2.0		
LSO2805D			Either Output, Note 3	0			4.8
LSO2812D			Either Output, Note 3	0			2.3
LSO2815D			Either Output, Note 3	0			1.6

For Notes to Electrical Performance Characteristics, refer to page 7

Electrical Performance Characteristics (continued)

Parameter	Group A Subgroup	Conditions -55°C ≤ T _C ≤ +85°C V _{IN} = 28V DC ± 5%, C _L = 0 unless otherwise specified	Limits			Unit
			Min	Nom	Max	
Line regulation (V _{RLINE}) All Single and Dual Output Models	1,2,3	V _{IN} = 18, 28, 40 Volts I _{OUT} = 0, 50%, 100% rated, Note 4	-0.5		0.5	%
Load regulation (V _{RLOAD}) All Single Output Models	1,2,3	V _{IN} = 18, 28, 40 Volts I _{OUT} = 0, 50%, 100% rated, Note 4	-1.0		1.0	%
Total regulation (Line and Load)	1,2,3	V _{IN} = 18 to 40 Volts Min load to full load Dual model is measured from +Output to -Output, Note 13	-1.0		1.0	%
Cross regulation (V _{RCROSS}) LSO2805D LSO2812D LSO2815D	1,2,3	V _{IN} = 18, 28, 40 Volts Duals only, Note 5	-5.0 -3.0 -3.0		5.0 3.0 3.0	%
Input Current, no load (I _{IN}) LSO2801R5S LSO2801R8S LSO2802R5S LSO2803R3S LSO2805S LSO2812S LSO2815S LSO2805D LSO2812D LSO2815D	1,2,3	I _{OUT} = 0, Pin 3 open			60 60 60 60 70 70 70 70 100 100	mA
Input current inhibited	1,2,3	Pin 4 shorted to Pin 3			8.0	mA
Output Ripple (V _{RIP}) LSO2801R5S LSO2801R8S LSO2802R5S LSO2803R3S LSO2805S LSO2812S LSO2815S LSO2805D LSO2812D LSO2815D	1,2,3	V _{IN} = 18, 28, 40 Volts I _{OUT} = 100% rated load Notes 4, 6			35 35 35 35 50 70 50 50 50 50	mV p-p
Switching frequency (F _S)	1,2,3		425	500	575	KHz
Efficiency (E _{FF}) LSO2801R5S LSO2801R8S LSO2802R5S LSO2803R3S LSO2805S LSO2812S LSO2815S LSO2805D LSO2812D LSO2815D	1,2,3	I _{OUT} = 100% rated load Note 4	60 63 67 71 77 77 77 76 78 78	62 65 69 73 80 80 80 79 81 81		%
Input undervoltage lockout (UVLO) (turn off when input voltage decreasing)	1,2,3	No load to full load, Notes 1, 4	14.5		16.5	V
Input undervoltage release (UVR) (turn on when input voltage rising)	1,2,3	No load to full load, Notes 1, 4	15.5		17.9	V
Input undervoltage Hysteresis (UVR-UVLO)	1,2,3	No load to full load, Notes 1, 4	1.0		3.0	V
Input current telemetry ratio(ICT)	1,2,3	I _{OUT} = 100% rated load, Note 4	1.4		1.6	V/A

For Notes to Electrical Performance Characteristics, refer to page 7

LSO SERIES
28V Input, Single/Dual Output

Electrical Performance Characteristics (continued)

Parameter	Group A Subgroup	Conditions $-55^{\circ}\text{C} \leq T_C \leq +85^{\circ}\text{C}$ $V_{IN} = 28\text{V DC} \pm 5\%$, $C_L = 0$ unless otherwise specified	Limits			Unit
			Min	Nom	Max	
Overvoltage protection (OVP) Output voltage threshold (for single and each of dual output models)	1,2,3	No load to full load, Notes 1, 4	115		125	% of nominal Vout
Enable Input (Inhibit Function) open circuit voltage drive current (sink) voltage range		Note 1	3.0 -0.5		5.0 5.0 50	V mA V
Current Limit Point Expressed as a percentage of full rated load current	1,2,3	$V_{OUT} = 90\%$ of Nominal, Note 4	105		145	%
Power dissipation, load fault (P _D)	1,2,3	Short Circuit, Overload, Note 8			16	W
Output response to step load changes (V _{TLD})	4,5,6	Half Load to/from Full Load, Notes 4,9	-300		300	mV pk
Recovery time, step load changes (T _{TLD})	4,5,6	Half Load to/from Full Load, Notes 4,9,10			200	μs
Output response to step line changes (V _{TLN})		18V to/from 40V $I_{OUT} = 100\%$ rated load, Notes 1,4,11	-300		300	mV pk
Recovery Time, step line changes (T _{TLN})		18V to/from 40V $I_{OUT} = 100\%$ rated load, Notes 1, 4,10,11			200	μs
Turn-on Overshoot (V _{OS}) All Single and Dual Output Models Turn-on Delay (T _{DLY}) All Single and Dual Output Models	4,5,6	10% Load, Full Load Notes 4,12	0		50 10	mV ms
Capacitive Load (C _L) LSO2801R5S LSO2801R8S LSO2802R5S LSO2803R3S LSO2805S LSO2812S LSO2815S LSO2805D LSO2812D LSO2815D		$I_{OUT} = 100\%$ rated load No effect on DC performance Notes 1, 4, 7 Each output on duals			2500 2500 2500 2200 1000 180 120 500 90 60	μF
Line Rejection	1	$I_{OUT} = 100\%$ rated load DC to 50KHz, Notes 1, 4	40	50		dB
Isolation	1	Input to Output or Any Pin to Case except Pin 6, test @ 100VDC	20			MΩ
Device Weight					125	g
MTBF		MIL-HDBK-217F2, SF, 35°C Note 14	4.0×10^6			Hr

For Notes to Electrical Performance Characteristics, refer to page 7

Notes for Electrical Performance Characteristics Table

1. Parameter is tested as part of design characterization or after design changes. Thereafter, parameter shall be guaranteed to the limits specified.
2. Parameter verified during line and load regulation tests.
3. Output load current must be distributed such that at least 20% of the total load current is being provided by one of the outputs.
4. Load current split equally between outputs on dual output models.
5. Cross regulation is measured with 20% rated load on output under test while changing the load on the other output from 20% to 80% of rated.
6. Guaranteed for a D.C. to 20MHz bandwidth. Tested using a 20KHz to 10MHz bandwidth using the circuit shown in Fig.1.
7. Capacitive load may be any value from 0 to the maximum limit without compromising dc performance. For a capacitive load in excess of the maximum limit, consult the factory.
8. Overload power dissipation is defined as the device power dissipation with the load set such that $V_{OUT} = 90\%$ of nominal.
9. Load step transition time $\leq 10\mu s$.
10. Recovery time is measured from the initiation of the transient to where V_{OUT} has returned to within $\pm 1\%$ of its steady state value.
11. Line step transition time $\leq 100\mu s$.
12. Turn-on delay time from either a step application of input power or a logic low to a logic high transition on the inhibit pin (pin 3) to the point where $V_{OUT} = 90\%$ of nominal.
13. End of life (EOL) is $\pm 3\%$
14. MIL-HDBK MOSFET failure rates replaced by empirical failure rate data supplied by International Rectifier.

Fig. 1 - Circuit for measuring Output Ripple Voltage

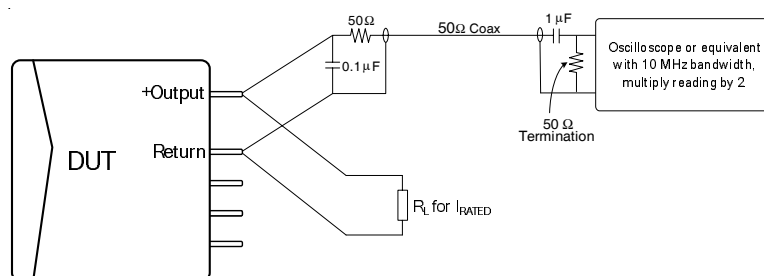

Radiation Performance Characteristics

Test Inspection	Method	Min	Typ	Unit
Total Ionizing Dose (Gamma)	MIL-PRF-883, Method 1019 Operating bias applied during exposure, Full Rated Load, $V_{IN} = 28V$	100	150	Krads(Si)
Single Event Effects SEU, SEL, SEGR, SEB	Heavy Ions (LET) Operating bias applied during exposure, Full Rated Load, $V_{IN} = 28V$ Test lab: Cyclotron Institute Texas A & M University	82		MeV·cm ² /mg

LSO SERIES
28V Input, Single/Dual Output

Fig. 2 - Single Output Block Diagram

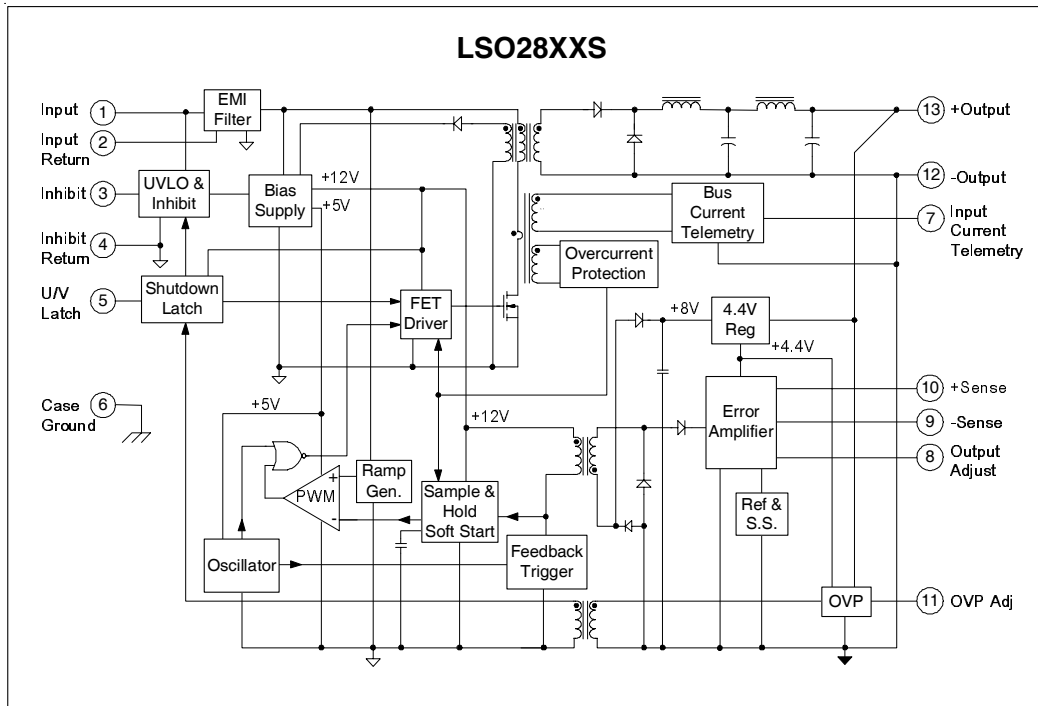
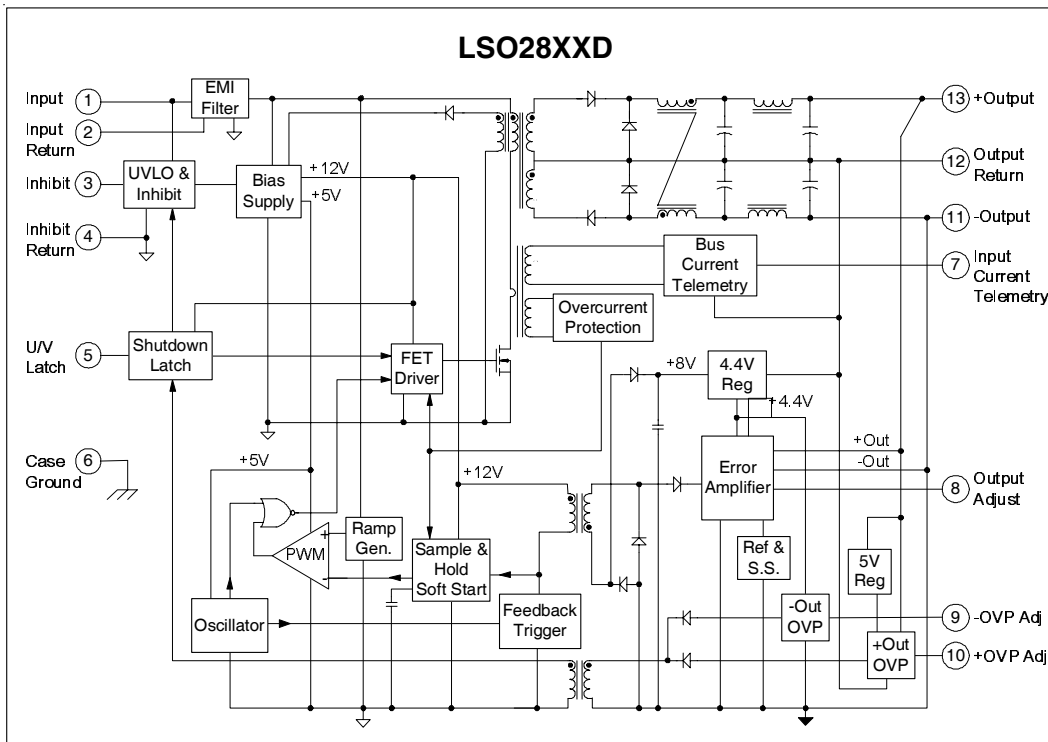
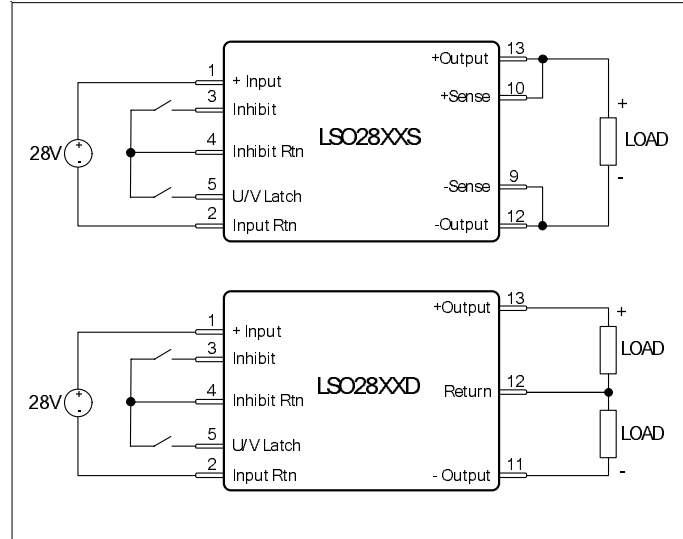

Fig. 3 - Dual Output Block Diagram



Application Notes:

Fig. 4 - Typical Connections Diagram



Inhibit Function:

The converter is disabled when the INHIBIT pin is shorted to the INHIBIT RETURN with an impedance less than or equal to 1K ohm, and that the converter be enabled when the impedance between the INHIBIT pin and INHIBIT RETURN is greater than or equal to 500K ohms.

Fig. 5 - Inhibit Function

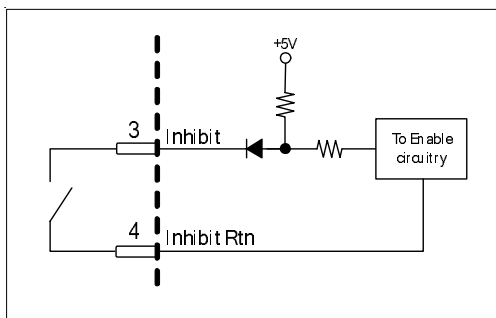

Remote Sense:

A remote sense feature maintains the desired output voltage regulation at the load. It corrects the voltage drop along the conductors between converter's output and the load. To use this function connect \pm sense pins directly to the load as shown in Fig. 6. To use a converter without remote sense function, connect the \pm sense pins to output pins respectively. This function is available just on single output models.

Fig. 6 - Remote Sense - Single Models

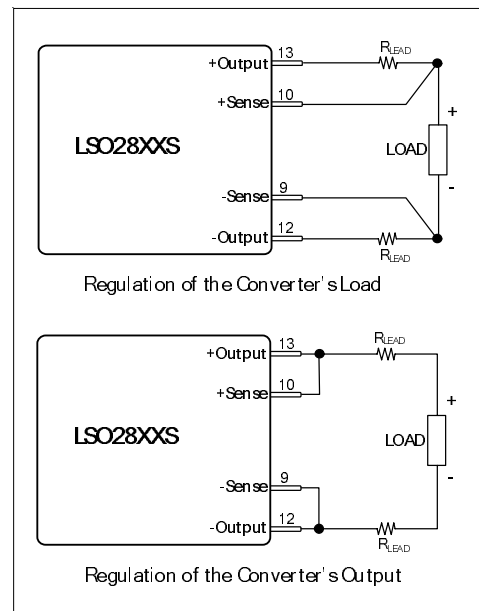

LSO SERIES

28V Input, Single/Dual Output

Output Voltage Adjustment:

Output of LSO singles and duals can be adjusted to be greater or less the nominal output voltage with an external resistor. However, the ranges of the output voltages are limited depending on the model as specified in Table 1 and Table 2. An approximate value of the resistor can be determined using the following formula.

For Single Output Model:

$$R_{adj} = \frac{A - (B * V_{out})}{(C * V_{out}) - D}$$

For Dual Output Model:

$$R_{adj} = \frac{A - (B * 2 * V_{out})}{(C * 2 * V_{out}) - D}$$

Where:

R_{adj} is the external resistor in ohms, as shown in Fig 7. Power rating of the resistor shall be ≥ 0.125 W. Metal film resistor with temperature coefficient of $\leq \pm 50$ ppm and tolerance of $\leq 1\%$ is recommended. However, the final selection is dependent on specific design requirements.

V_{ovp} is the output voltage in volts.

A, B, C and D are unique constants depending on every model as shown in Table 1 for single output models and Table 2 for dual output models.

Placement of R_{adj} : An external resistor must be added in order to trim the output voltage of a LSO converter. The placement of a R_{adj} resistor must be connected as shown in Fig. 7.

Singles: R_{adj} is placed across Out Adj and \pm Sense pins. For output voltage greater than nominal voltage, R_{adj} is placed from Out Adj to $-Sense$. To have output voltage less than nominal voltage, place R_{adj} across Out Adj and $+Sense$.

Duals: R_{adj} is placed across Out Adj and \pm Output pins respectively.

Table 1. LSO2803R3S. Output Voltage Ranges and Constants

	Output voltage Low range	Output voltage High range
Constants	3.135 to 3.300	3.300 to 3.465
A	466.4×10^6	466.0×10^6
B	238.3×10^6	84.0×10^6
C	9550	9550
D	31489	31489

Table 2. LSO2805S. Output Voltage Ranges and Constants

	Output voltage Low range	Output voltage High range
Constants	4.750 to 5.000	5.000 to 5.250
A	588.3×10^6	587.8×10^6
B	264.5×10^6	699.6×10^6
C	7950	7950
D	39716	39717

Table 3. LSO2815S. Output Voltage Ranges and Constants

	Output voltage Low range	Output voltage High range
Constants	14.250 to 15.000	15.000 to 15.750
A	588.3×10^6	1451.2×10^6
B	264.5×10^6	57.5×10^6
C	7950	6540
D	39716	39717

Table 4. LSO2805D. Output Voltage Ranges and Constants

	Output voltage Low range	Output voltage High range
Constants	± 4.750 to ± 5.000	± 5.000 to ± 5.250
A	1012.4×10^6	1011.5×10^6
B	395.0×10^6	60.1×10^6
C	6840	6840
D	68344	68344

Table 5. LSO2815D. Output Voltage Ranges and Constants

	Output voltage Low range	Output voltage High range
Constants	± 14.250 to ± 15.000	± 15.000 to ± 15.750
A	2780.2×10^6	2777.9×10^6
B	974.8×10^6	55.0×10^6
C	6260	6260
D	187646	187646

Fig. 7 - Output Voltage Adjustment

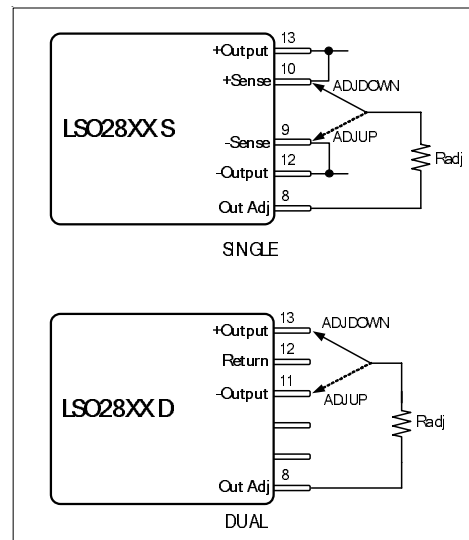

OVP External Adjustment:

Over-voltage Protection threshold of LSO singles and duals can be adjusted to be greater or less the nominal OVP with a couple of external resistors. Lower resistors, *R1* and *R2* are 10KΩ resistors, while *Radj* set the new OVP threshold as stated in Table 6 for single output models and Table 7 for dual output models. Ranges of LSO series converter can be adjusted from 115% to 125% of the nominal output voltage. See Fig.8 to place external resistors.

An approximate value of the resistor can be determined using the following formula.

$$Radj = \frac{(A * V_{ovp}) - B}{C - (D * V_{ovp})}$$

Where:

Radj is the upper external resistor in kilo-ohms, as shown in Fig 8. Power rating of the resistor shall be ≥ 0.125 W. Metal film resistor with temperature coefficient of ≤ ± 50 ppm and tolerance of ≤ 1% is recommended. However, the final selection is dependent on specific design requirements.

V_{ovp} is the output voltage protection limit in volts.

A, B, C and D are unique constants depending on every model.

Placement of Radj: Two external resistors must be added in order to set new OVP threshold.

Singles: Radj(OVP) is placed across +Output and OVP Adj pins and R1 from OVP Adj to -Output.

Duals: Radj(+OVP) is placed across +Output and +OVP Adj pins and R1 from +OVP Adj to -Return. Radj(-OVP) is placed across +Return and -OVP Adj pins while R2 is placed across -OVP Adj to -Output.

Table 6. LSO Singles. OVP Exeternal

Range	LSO2803R3S		LSO2805S		LSO2815S	
	OVP	Radj (KΩ)	OVP	Radj (KΩ)	OVP	Radj (KΩ)
Vo* (115%)	3.79	13	5.75	26	17.25	102
Vo* (116%)	3.82	15	5.80	28	17.40	108
Vo* (117%)	3.86	16	5.85	31	17.55	114
Vo* (118%)	3.89	18	5.90	33	17.70	121
Vo* (119%)	3.92	20	5.95	36	17.85	128
Vo* (120%)	3.96	22	6.00	39	18.00	137
Vo* (121%)	3.99	25	6.05	42	18.15	146
Vo* (122%)	4.02	28	6.10	46	18.30	157
Vo* (123%)	4.05	31	6.15	51	18.45	168
Vo* (124%)	4.09	36	6.20	56	18.60	181
Vo* (125%)	4.12	41	6.25	63	18.75	197

Table 7. LSO Duals. OVP Exeternal

Range	LSO2805DS		LSO2815D	
	OVP	Radj (KΩ)	OVP	Radj (KΩ)
Vo* (115%)	5.75	26	17.25	101
Vo* (116%)	5.80	28	17.40	107
Vo* (117%)	5.85	30	17.55	113
Vo* (118%)	5.90	33	17.70	121
Vo* (119%)	5.95	36	17.85	128
Vo* (120%)	6.00	39	18.00	137
Vo* (121%)	6.05	43	18.15	146
Vo* (122%)	6.10	47	18.30	157
Vo* (123%)	6.15	51	18.45	169
Vo* (124%)	6.20	57	18.60	183
Vo* (125%)	6.25	64	18.75	199

Fig. 8 - OVP with External Adjustment

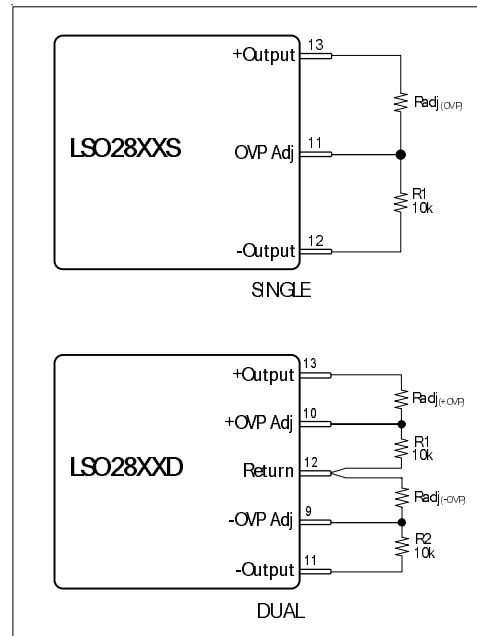

Stacking Outputs:

On dual output models, output can be stacked to double the output voltage as shown in Fig 9.

Fig. 9 - Stacked Outputs on Dual Models

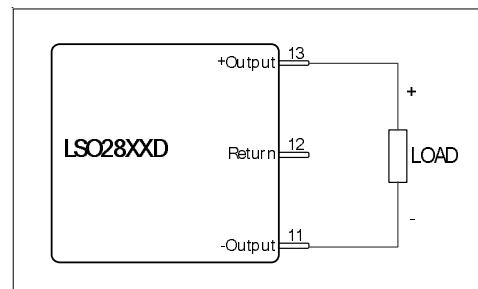

LSO SERIES
28V Input, Single/Dual Output

Typical Performance Curves: 25°C Tc, 28 Vdc VIN, Rated Load, unless otherwise specified

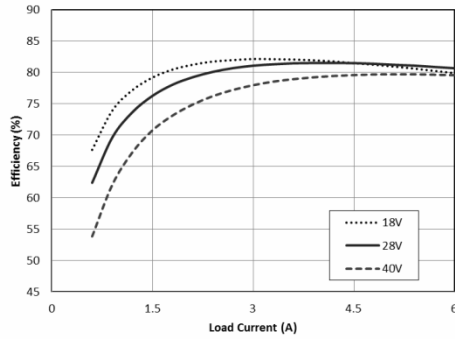

Fig. 10 - LSO2805S Efficiency

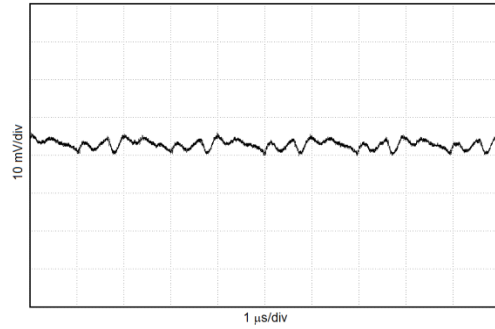

Fig. 11 - LSO2805S Output Ripple

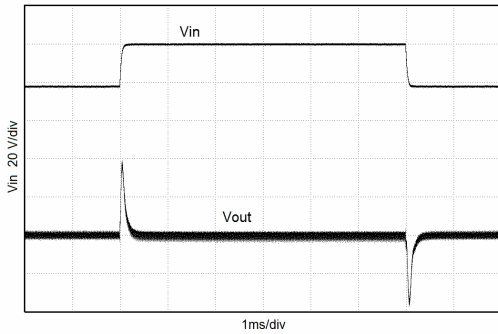

Fig. 12 - LSO2805S Step Line Response, 18V to/from 40V.

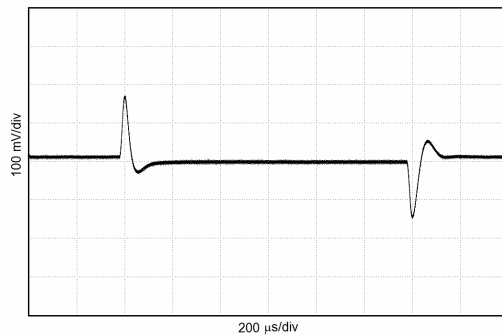

Fig. 13 - LSO2805S Step Load Response, Half Load to/from Full Load, 0.25A/μs Slew Rate.

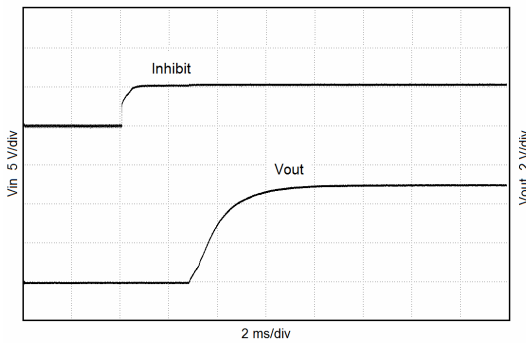

Fig. 14 - LSO2805S Turn On Response

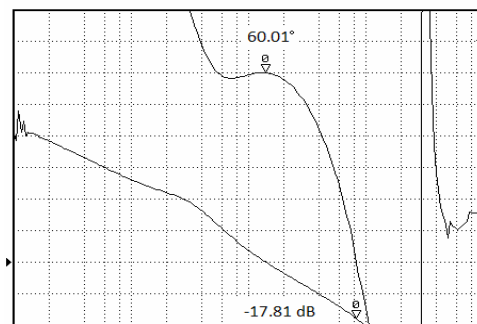

Fig. 15 - LSO2805S Loop Response, Phase = 60.01° and Gain = -17.81dB

Typical Performance Curves: 25°C Tc, 28 VDC VIN, Rated Load, unless otherwise specified

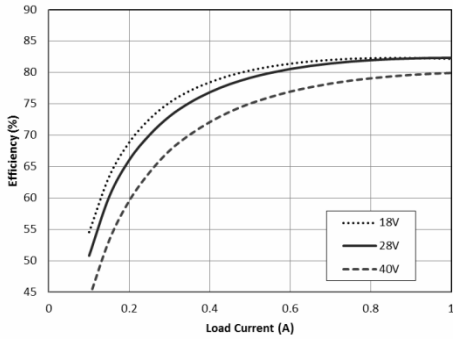

Fig. 16 - LSO2815D Efficiency

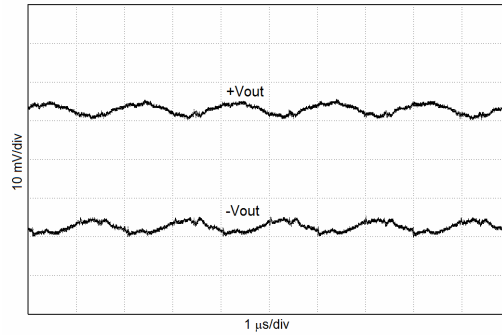

Fig. 17 - LSO2815D Output Ripple

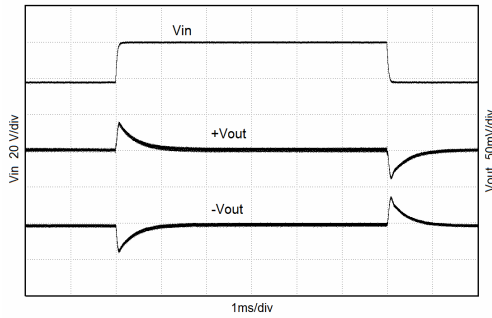

Fig. 18 - LSO2815D Step Line Response, 18V to/from 40V.

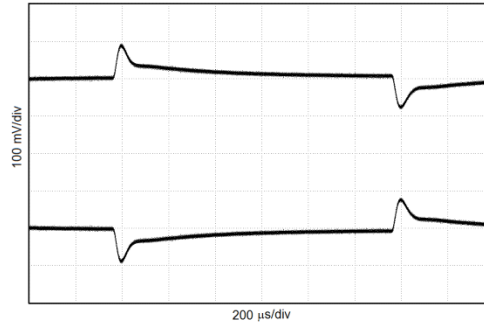

Fig. 19 - LSO2815D Step Load Response, Half Load to/from Full Load, 0.05A/μs Slew Rate.

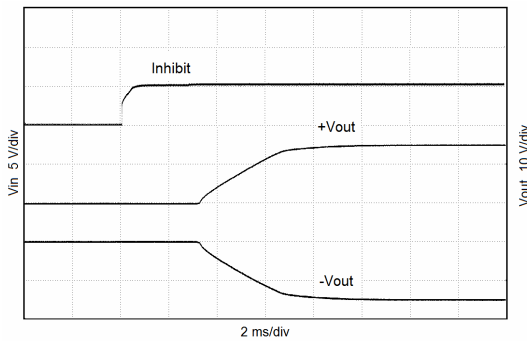

Fig. 20 - LSO2815D Turn On Response

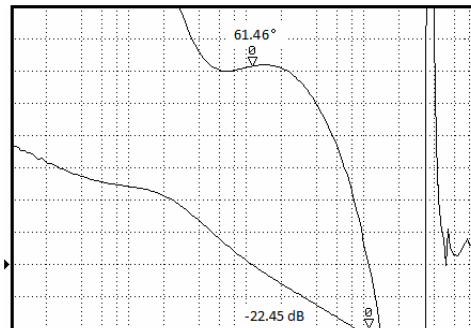

Fig. 21 - LSO2815D Loop response, Phase = 61.46° and Gain = -22.45dB

LSO SERIES
28V Input, Single/Dual Output

Typical Performance Curves: 25°C T_c, 28 VDC V_{IN}, Rated Load, unless otherwise specified

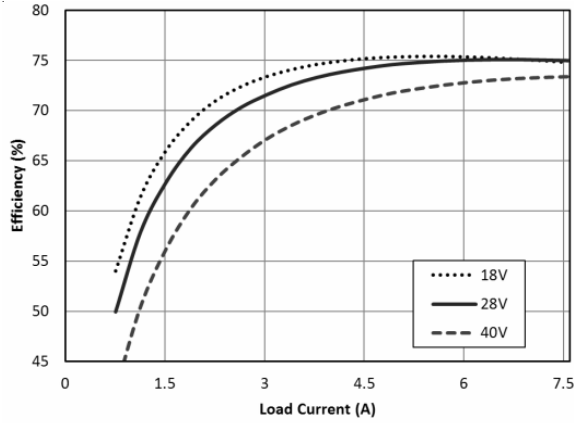

Fig. 22 - LSO2803R3S Efficiency.

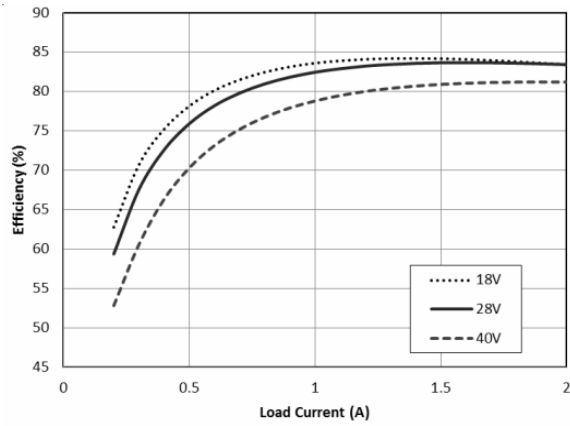

Fig. 23 - LSO2815S Efficiency.

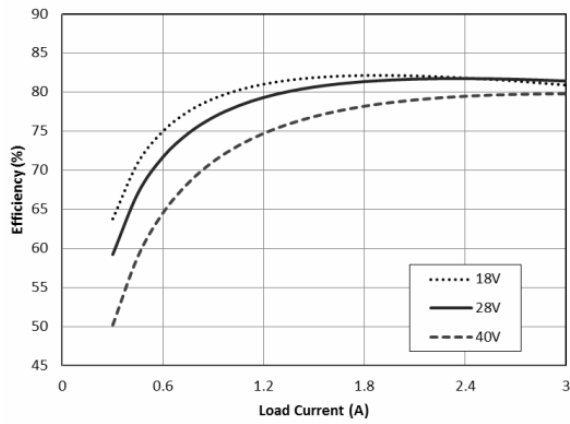

Fig. 24 - LSO2805D Efficiency.

Typical Performance Curves: 25°C Tc, 28 VDC VIN, Rated Load, unless otherwise specified

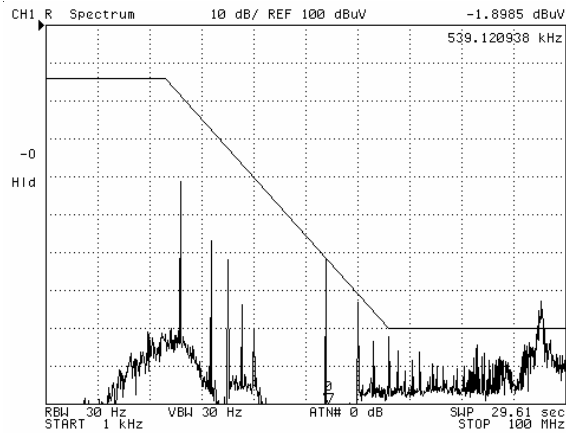

Fig. 25 - LSO2805S Full Load, Common Mode, Negative Lead.

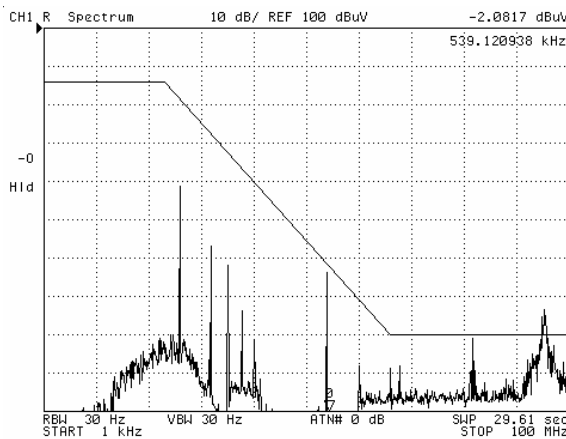

Fig. 26 - LSO2805S Full Load, Common Mode, Positive Lead.

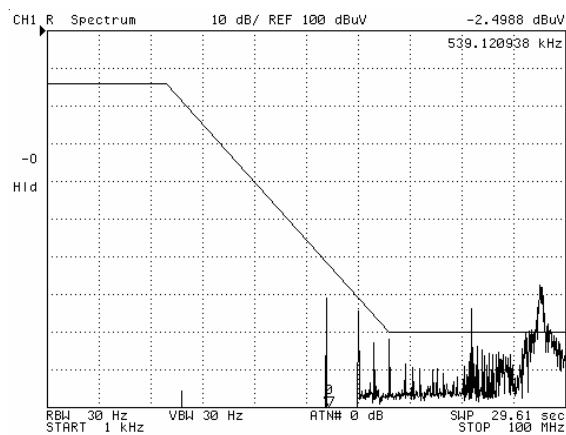

Fig. 27 - LSO2805S Full Load, Common Mode, Positive Lead.

LSO SERIES
28V Input, Single/Dual Output

Typical Performance Curves: 25°C Tc, 28 VDC VIN, Rated Load, unless otherwise specified

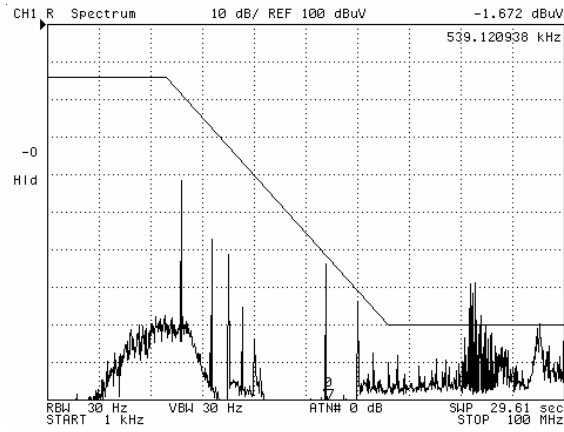

Fig. 28 - LSO2815D Full Load, Common Mode, Negative Lead.

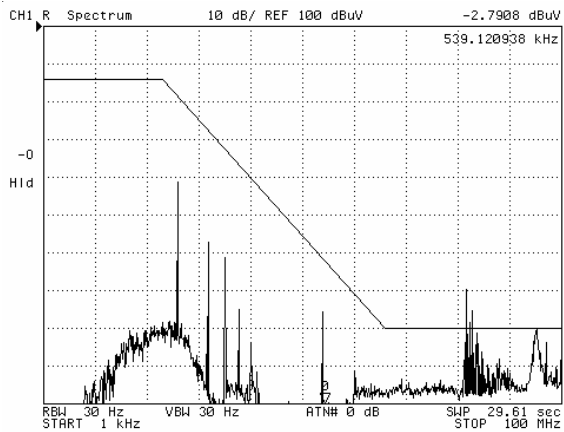

Fig. 29 - LSO2815D Full Load, Common Mode, Positive Lead.

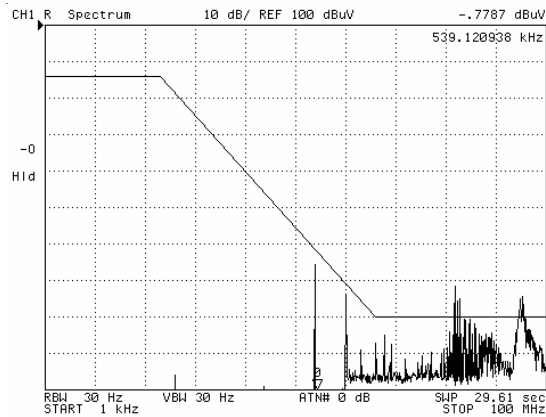
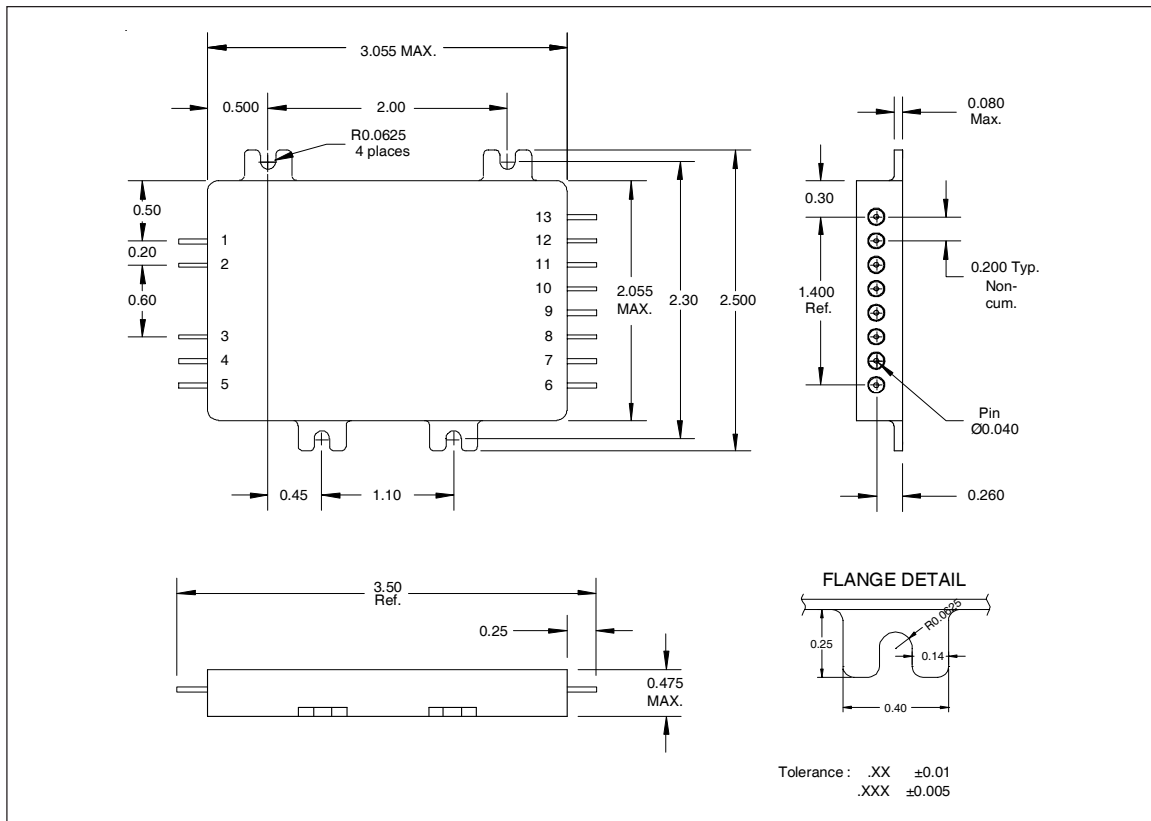

Fig. 30 - LSO2815D Full Load, Common Mode, Positive Lead.

Mechanical Outline



Note: Standard leads finish is solder dipped.

Pin Designation (Single/Dual)

Pin #	Single	Dual
1	Input	Input
2	Input Return	Input Return
3	Inhibit	Inhibit
4	Inhibit Return	Inhibit Return
5	U/V Latch	U/V Latch
6	Case Ground	Case Ground
7	Input Current Telemetry	Input Current Telemetry
8	Output Adjust	Output Adjust
9	- Sense	- OVP Adjust
10	+ Sense	+ OVP Adjust
11	OVP Adjust	- Output
12	- Output	Output Return
13	+ Output	+ Output

LSO SERIES
28V Input, Single/Dual Output

International
IR Rectifier

Device Screening

Requirement	MIL-STD-883 Method	No Suffix (Flight Model)	EM (Engineering Model)
Temperature Range	—	-55°C to +85°C	-55°C to +85°C
Element Evaluation	MIL-PRF-38534	Class K	N/A
Non-Destruction Bond Pull	2023	YES	N/A
Internal Visual	2017	YES	⓪
Temperature Cycle	1010	Cond C	Cond C
Constant Acceleration	2001, Y1 Axis	3000 Gs	3000 Gs
PIND	2020	Cond A	N/A
Burn-In	1015	320 hrs @ 125°C (2 x 160 hrs)	48 hrs @ 125°C
Final Electrical (Group A)	MIL-PRF-38534 & Specification	-55°C, +25°C, +85°C	-55°C, +25°C, +85°C
PDA	MIL-PRF-38534	2%	N/A
Seal, Fine and Gross	1014	Cond A, C	Cond A
Radiographic	2012	Yes	N/A
External Visual	2009	Yes	⓪

Notes:

⓪ Best commercial practice

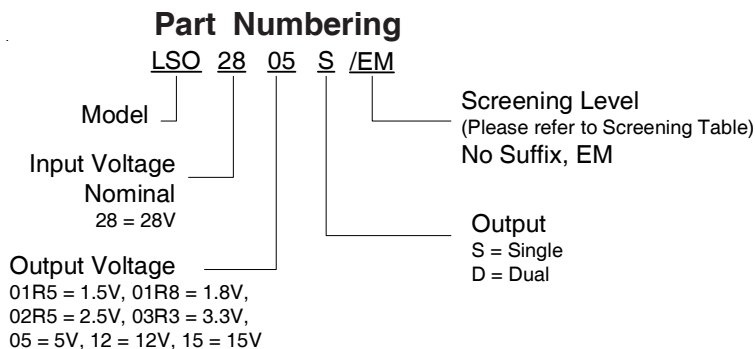

International
IR Rectifier

WORLD HEADQUARTERS: 101 N, Sepulveda Blvd., El Segundo, California 90245, USA Tel: (310) 252-7105
IR SAN JOSE: 2520 Junction Avenue, San Jose, California 95134, USA Tel: (408) 434-5000
 Visit us at www.irf.com for sales contact information.

Data and specifications subject to change without notice. 08/2013