

# TESD\*\*G2B SERIES

## BIDIRECTIONAL TVS DIODE ARRAY FOR LATCH-UP PROTECTION

### APPLICATIONS

- ◆ RS-232, RS-422 & RS-423 Data Lines
- ◆ Audio/Video Inputs
- ◆ Wireless Network Systems
- ◆ Digit Video Interface (DVI)
- ◆ Medical Sensors
- ◆ Notebook Computers

### IEC COMPATIBILITY

- ◆ IEC61000-4-2 (ESD)  $\pm 30\text{kV}$  (air),  $\pm 30\text{kV}$  (contact) -- 3.3V~18V
- ◆ IEC61000-4-2 (ESD)  $\pm 15\text{kV}$  (air),  $\pm 8\text{kV}$  (contact) -- 24V~36V
- ◆ IEC61000-4-4 (EFT) 40A (5/50  $\eta$  s)
- ◆ IEC61000-4-5 (Lightning) 21A (8/20 $\mu$ s)

### FEATURES

- ◆ 350 Watts Peak Pulse Power per Line ( $t_p=8/20\mu$ s)
- ◆ Protects two bi-directional I/O lines
- ◆ Low clamping voltage
- ◆ Working voltages : 3.3V to 36V
- ◆ Low leakage current

### MECHANICAL CHARACTERISTICS

- ◆ SOT-23 Package
- ◆ Molding Compound Flammability Rating : UL 94V-0
- ◆ Weight 8.0 Milligrams (Approximate)
- ◆ Quantity Per Reel : 3,000pcs
- ◆ Reel Size : 7 inch
- ◆ Lead Finish : Lead Free

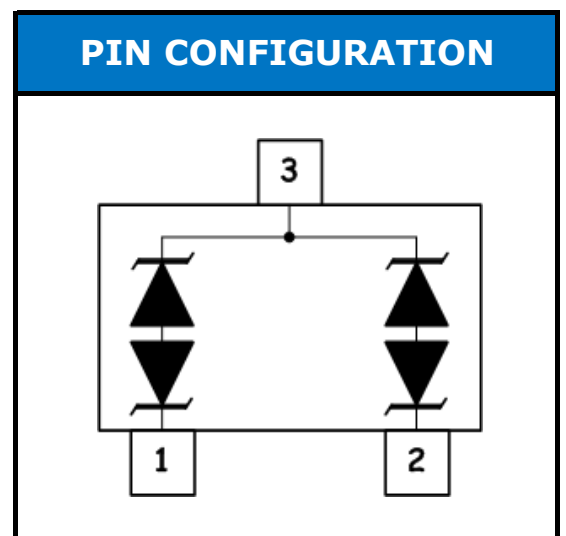
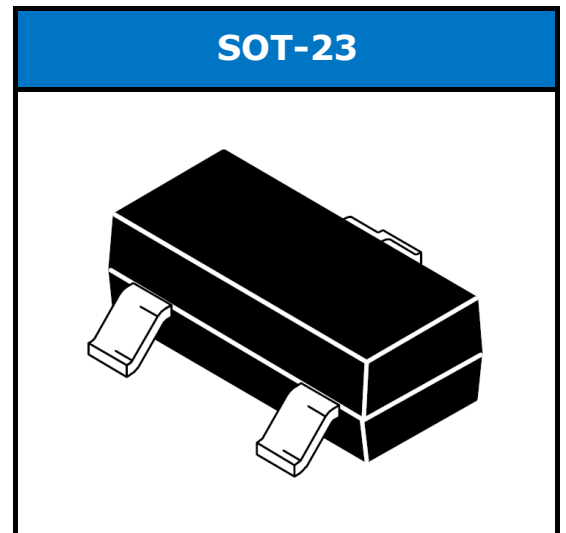

# TESD\*\*G2B SERIES

## DEVICE CHARACTERISTICS

MAXIMUM RATINGS (@ 25°C Unless Otherwise Specified)			
PARAMETER	SYMBOL	VALUE	UNITS
Peak Pulse Power (tp=8/20μs waveform)	P <sub>PP</sub>	350	Watts
Lead Soldering Temperature	T <sub>L</sub>	260 (10 sec.)	°C
Operating Temperature Range	T <sub>J</sub>	-55 ~ 150	°C
Storage Temperature Range	T <sub>STG</sub>	-55 ~ 150	°C

ELECTRICAL CHARACTERISTICS PER LINE (@ 25°C Unless Otherwise Specified)									
PART NUMBER	DEVICE MARKING	V <sub>RWM</sub>	V <sub>B</sub>	I <sub>T</sub>	V <sub>C</sub>	V <sub>C</sub>		I <sub>R</sub>	C <sub>T</sub>
		(V) (max.)	(V) (min.)	(mA)	@1A (max.)	(max.)	(@A)	(μA) (max.)	(pF) (typ.)
TESD03G2B	C03	3	4	1	7	10.5	20	40	220
TESD05G2B	C05	5	6	1	9.8	18	10	10	150
TESD08G2B	C08	8	8.5	1	13.4	24	12	1	75
TESD12G2B	C12	12	13.3	1	19	32	5	1	65
TESD15G2B	C15	15	16.7	1	24	38	5	1	60
TESD18G2B	C18	18	20	1	29	45	9	1	55
TESD24G2B	C24	24	26.7	1	43	52	7	1	40
TESD36G2B	C36	36	40	1	60	75	5	1	15

ESD Clamping  
(8kV Contact per IEC 61000-4-2)

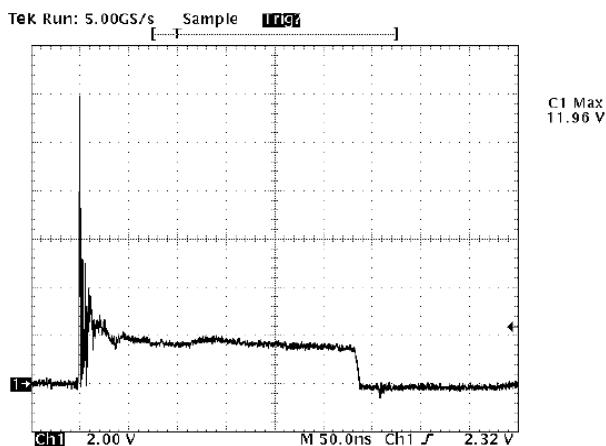

ESD Clamping  
(-8kV Contact per IEC 61000-4-2)

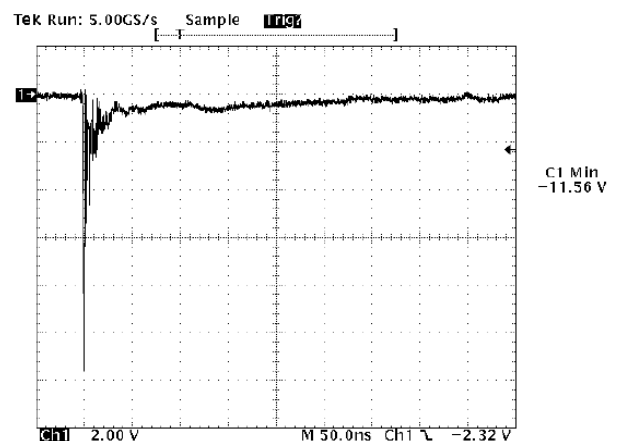

# TESD\*\*G2B SERIES

## SOT-23 PACKAGE OUTLINE & DIMENSIONS

DIM	MILLIMETERS			INCHES		
	MIN	NOM	MAX	MIN	NOM	MAX
A	0.89	1.00	1.11	0.035	0.040	0.044
A1	0.01	0.06	0.10	0.001	0.002	0.004
b	0.37	0.44	0.50	0.015	0.018	0.020
c	0.09	0.13	0.18	0.003	0.005	0.007
D	2.80	2.90	3.04	0.110	0.114	0.120
E	1.20	1.30	1.40	0.047	0.051	0.055
e	1.78	1.90	2.04	0.070	0.075	0.081
L	0.35	0.54	0.69	0.014	0.021	0.029
HE	2.10	2.40	2.64	0.083	0.094	0.104

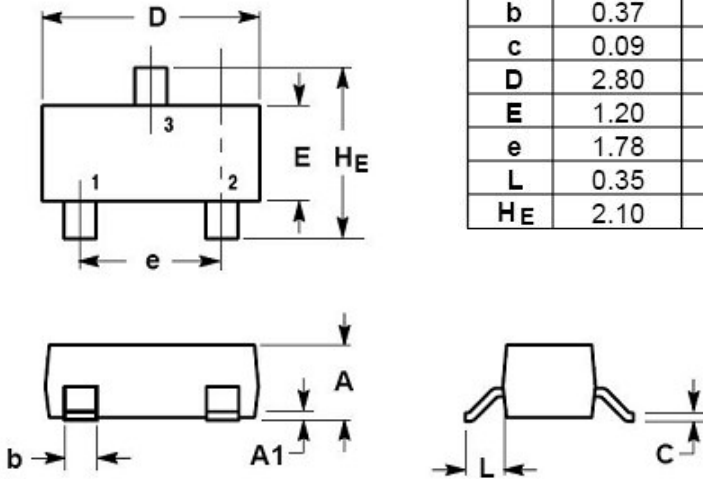

### \* SOLDERING FOOTPRINT

