

25 W mono BTL class-D audio amplifier demonstration board based on the TDA7491MV

Introduction

The STEVAL-CCA043V1 is a demonstration board designed for the evaluation of the TDA7491MV mono BTL class-D audio amplifier. This application note provides the board specifications and a quick-start list for standalone operation. Also included are the schematic, printed circuit board layout and bill of material.

Due to its high efficiency, the device, assembled in the PSSO36 (slug-down) package, is capable of dissipating heat without a heatsink. Jumpers on the board allow the configuration of the amplifier in order to verify the input signal as single-ended or differential and choose the fixed gain settings. Microswitches are also provided to enable the standby and mute functions.

The main features of the TDA7491MV include:

- 25 W continuous output power at THD = 10%, $R_L = 6 \Omega$, $V_{CC} = 16 V$
- 20 W continuous output power at THD = 10%, $R_L = 8 \Omega$, $V_{CC} = 18 V$
- Wide-range, single-supply operation (5 V - 18 V)
- High efficiency ($\eta = 90\%$)
- Four selectable, fixed gain settings (20 dB, 26 dB, 30 dB and 32 dB)
- Differential inputs to minimize common-mode noise
- Filterless operation up to 15 W, $R_L = 8 \Omega$, $V_{CC} = 18 V$
- Standby and mute features
- Short-circuit and thermal overload protections
- Externally synchronizable

Figure 1. STEVAL-CCA043V1

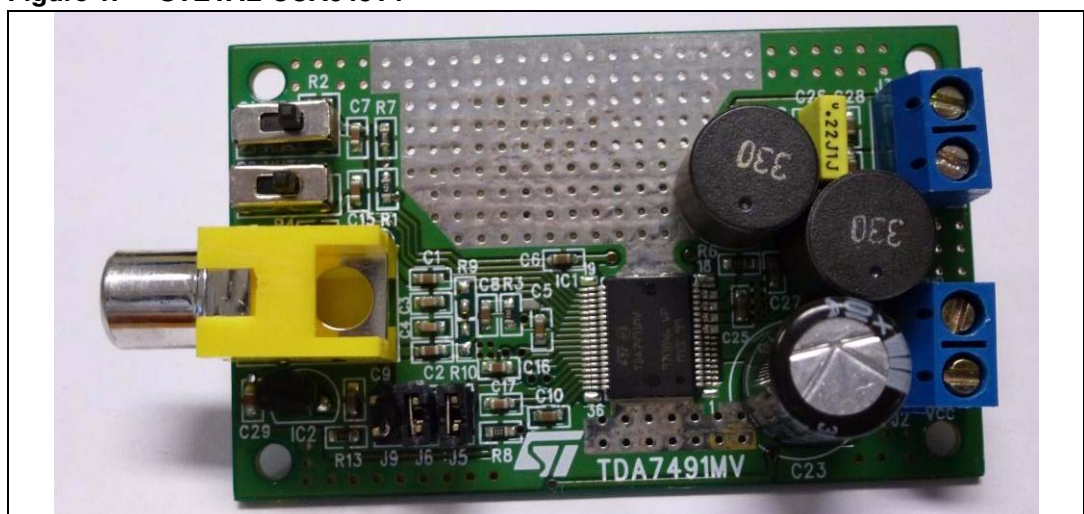

Contents

1	Operation	3
1.1	Power supply	3
1.2	Demonstration board preparation	3
1.3	Inputs and outputs	3
1.4	Powering up	4
1.5	Gain settings	5
1.6	Single-ended or differential input	5
1.7	Board schematic and bill of material	6
2	PCB layout	8
2.1	Layout views	8
2.2	Design guidelines for PCB schematic and layout	9
2.2.1	Dumping network	9
2.2.2	Main filter	10
2.2.3	Layout recommendations	11
3	Revision history	13

1 Operation

The TDA7491MV demonstration board specifications are as follows:

- Power supply voltage range: 5 V to 18 V
- Number of channels: 1 BTL (Bridge-Tied Load)
- Load impedance: 4 Ω to 8 Ω
- Gain settings: 20 dB, 26 dB, 30 dB, 32 dB
- Undervoltage protection (UVP): 4.5 V

1.1 Power supply

A single power supply is required to feed the TDA7491MV demonstration board via the connector J2 (see [Figure 2](#)).

Connect the positive voltage of the 25 V/3 A DC power supply to the +Vcc pin and the negative to GND.

Note: Voltage range 5 V to 18 V = 3 A current capability

1.2 Demonstration board preparation

1. Ensure that the power supply is switched OFF.
2. Connect the regulated power supply, adjusted in the device operating range, to the connector J2 (observe the polarity).

1.3 Inputs and outputs

1. Connect the loads across the connectors J3 (LEFT) and J4 (RIGHT), the specified impedance ranges from 6 to 8 Ω .
2. Connect the analog audio inputs, either differential or single-ended, to the L-input and R-input RCA plugs (J1).

Table 1. Input configuration

Input configuration	Jumper J8 (right)	Jumper J9 (left)
Differential	Open	Open
Single-ended	Closed	Closed

Refer to [Figure 2: Demonstration board connections on page 4](#).

Figure 2. Demonstration board connections

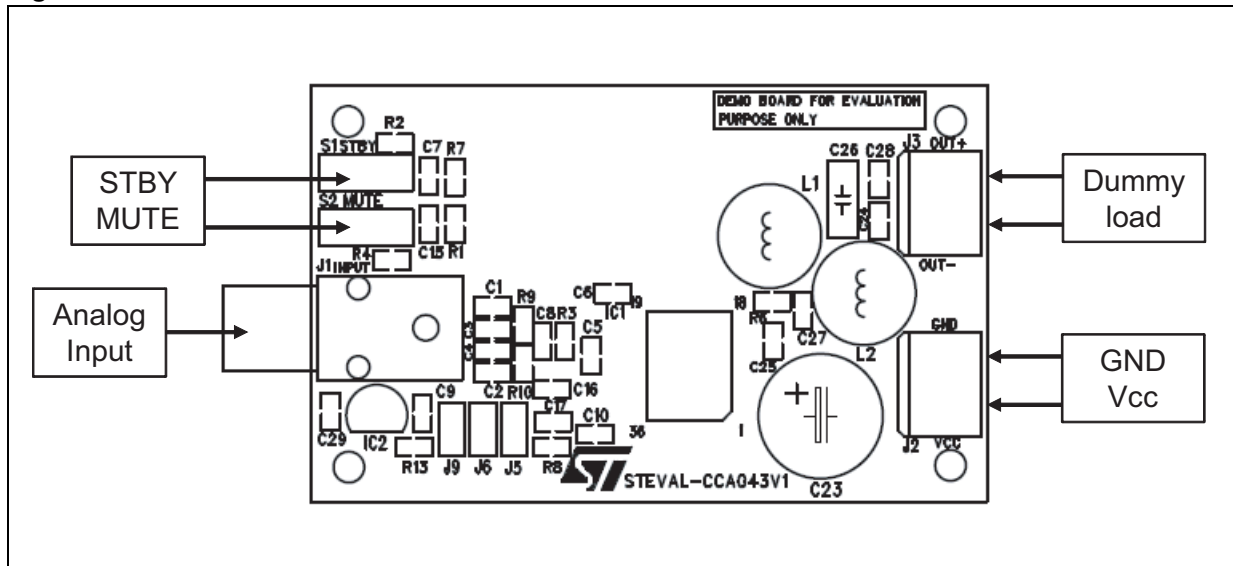

1.4 Powering up

Before powering up the demonstration board, ensure that the TDA7491MV is in standby and mute conditions and the gain is set to the desired value (default 20 dB). Verify also the dedicated switches and jumpers.

Table 2. Standby and mute settings

STBY (S1)	MUTE (S2)	Status
L	L	STBY
L	H	STBY
H	L	MUTE
H	H	PLAY

Figure 3. Standby and mute switches

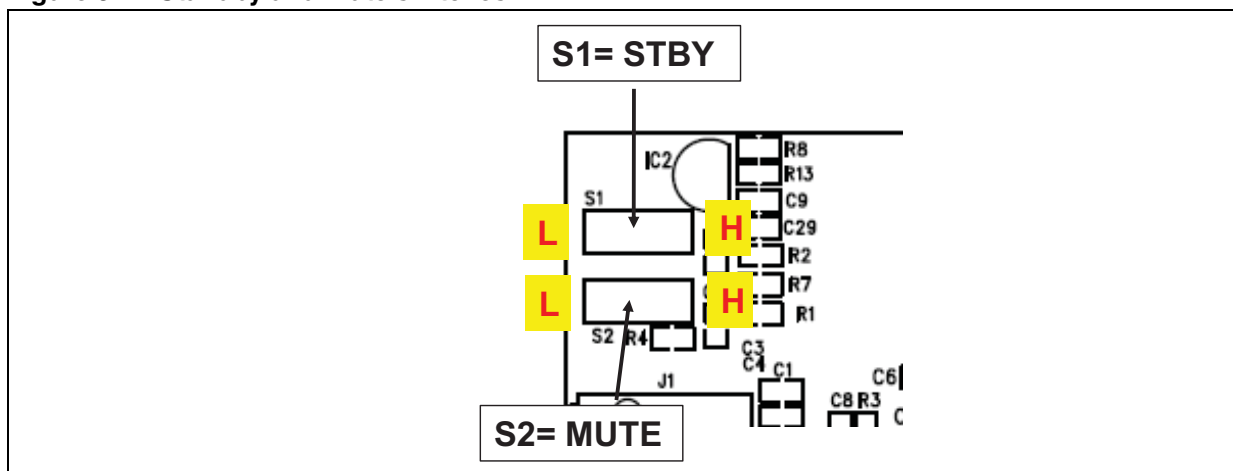

1.5 Gain settings

Table 3. Configuration of jumpers J5 and J6

Gain 0 (J5)	Gain 1 (J6)	Gain (db)
Open (L)	Open (L)	20
Open (L)	Closed (H)	26
Closed (H)	Open (L)	30
Closed (H)	Closed (H)	32

Figure 4. Jumpers J5 and J6

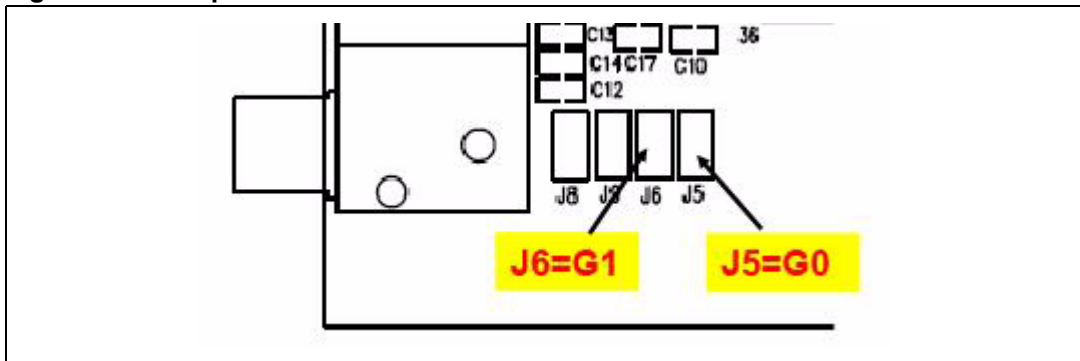

1.6 Single-ended or differential input

Jumper J9 is used to modify the input signal configuration.

Table 4. Configuration of jumper J9

Input configuration	Jumper (J9)
Differential	Open
Single-ended	Closed

Figure 5. Jumper J9

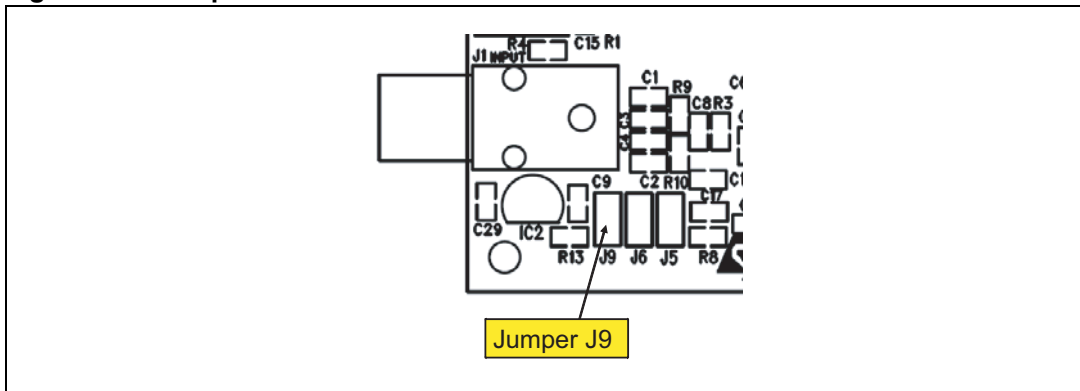

1.7 Board schematic and bill of material

Figure 6. STEVAL-CCA043V1 schematic

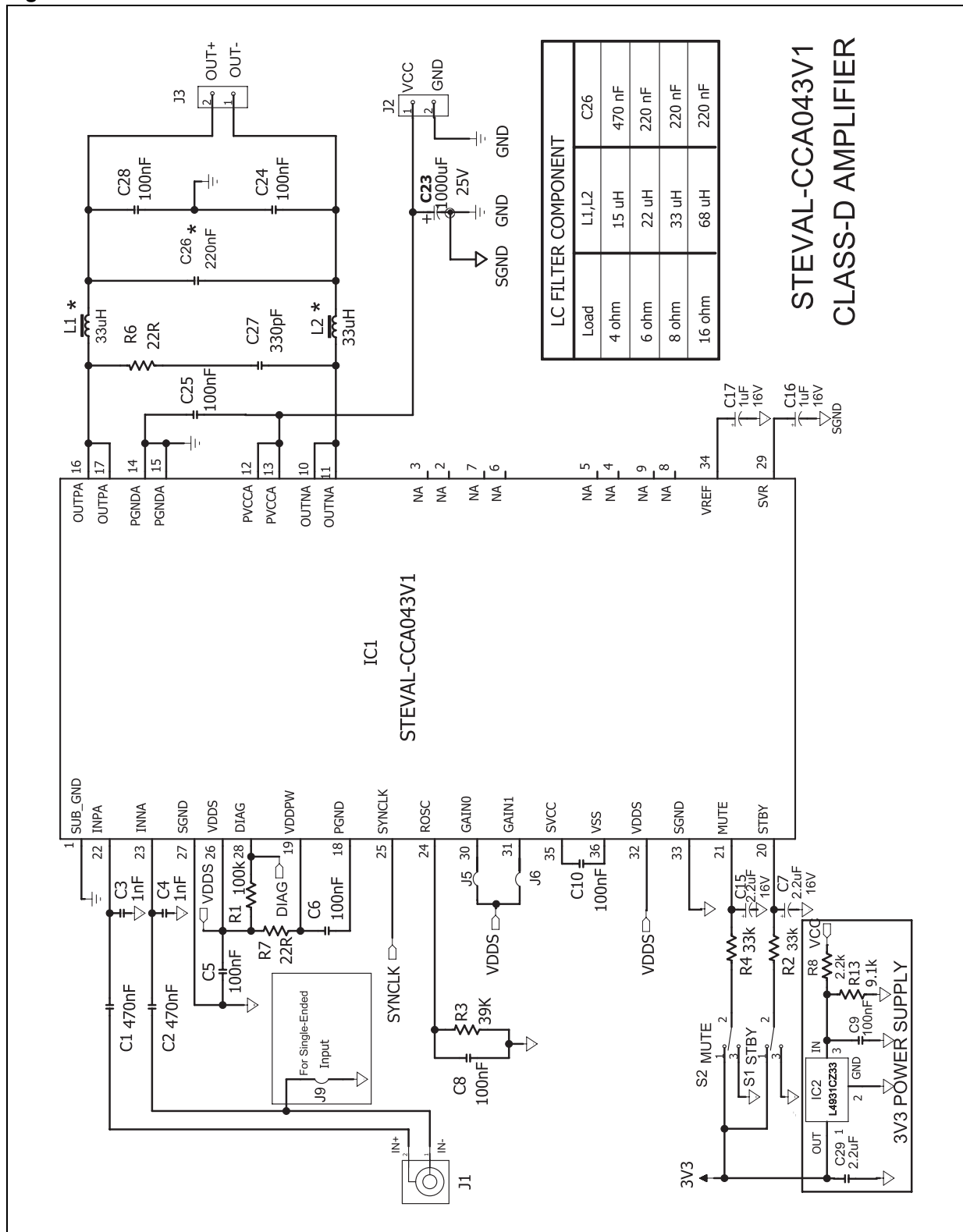

Table 5. Bill of material

Package	Description	Qty	Reference	Manufacturer
C0603	330 pF 50 V NPO $\pm 5\%$	1	C27	Murata
C0603	1 nF 50 V $\pm 10\%$	2	C3, C4	Murata
C0603	100 nF 50 V $\pm 10\%$	8	C5, C6, C8, C9, C10, C24, C25, C28	Murata
C0603	470 nF 50 V $\pm 10\%$	2	C1, C2	Murata
C0603	2.2 μ F, 16 V $\pm 10\%$	3	C7, C15, C29	Murata
C0603	1 μ F, 16 V, $\pm 10\%$	2	C16, C17	Murata
E-cap	1000 μ F, 25 V, $\pm 10\%$, pitch = 5.0 mm	1	C23	Rubycon
C1206	10 μ F, 25 V, $\pm 20\%$, Y5V	4	C30, C31, C32, C33	Murata
Mcap	220 nF, 50 V, $\pm 10\%$ PITCH=5.0mm	1	C26	Murata
R0603	22 ohm, $\pm 10\%$, 1/16 W	2	R6, R7	Murata
R0603	2.2k ohm, $\pm 10\%$, 1/16 W	1	R8	Murata
R0603	9.1k ohm, $\pm 10\%$, 1/16 W	1	R13	Murata
R0603	33k ohm, $\pm 10\%$, 1/16 W	2	R2, R4	Murata
R0603	39k ohm, $\pm 10\%$, 1/16 W	1	R3	Murata
R0603	100k ohm, $\pm 10\%$, 1/16 W	1	R1	Murata
PSSO36 slug-down	TDA7491MV (SSO36) slug-down	1	IC1	STMicroelectronics
Coil 10X10	33 μ h 2 A Type:7075P-330M ⁽¹⁾	2	L1, L2	Kwan Sung
RCA-2P	RCA socket 1X2P, type AV2-8.4-4	1	J1	Songcheng
TO92	L4931CZ33, 3V3 regulator	1	IC2	STMicroelectronics
CNN-Terminal	2P, pitch = 5 mm connector terminal	3	J2, J3	Any source
2-way jumper	2P, pitch = 2.5 mm jumper	4	J5, J6, J9	Any source
Slide switch	3P, pitch = 2.5 mm	2	S1, S2	Any source

1. Alternate part MSS1246/MSS1260

2 PCB layout

2.1 Layout views

Figure 7. Top view of PCB layout

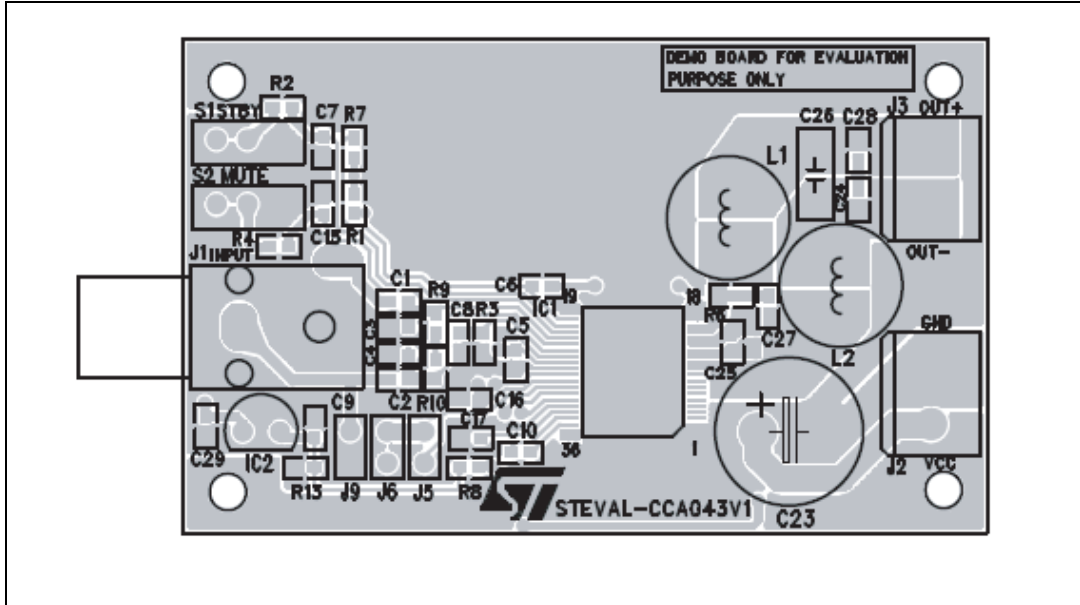

Figure 8. Bottom view of PCB layout

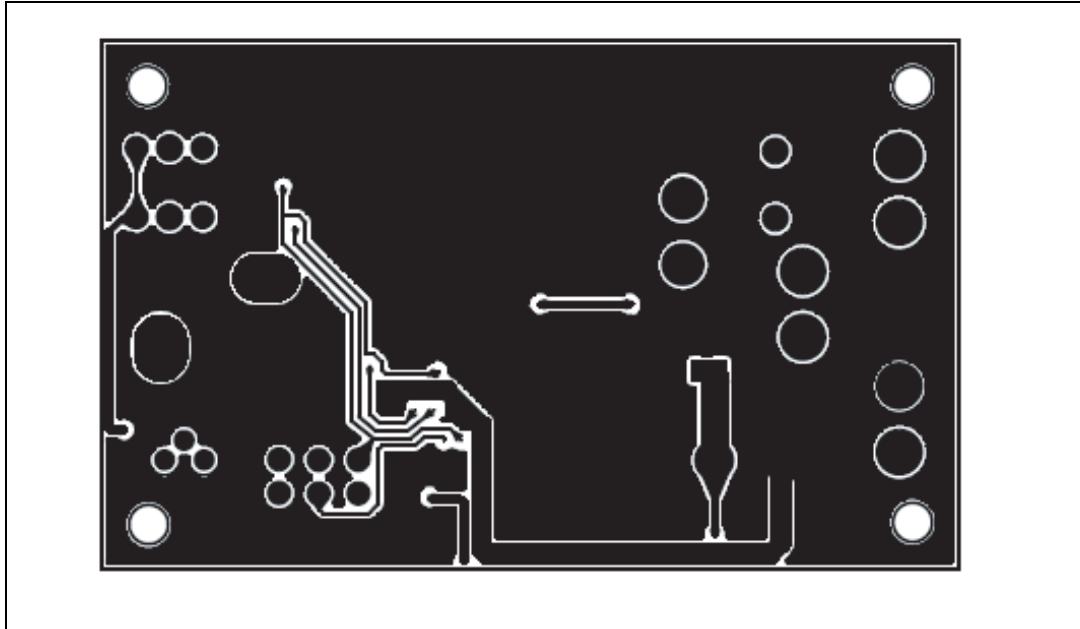
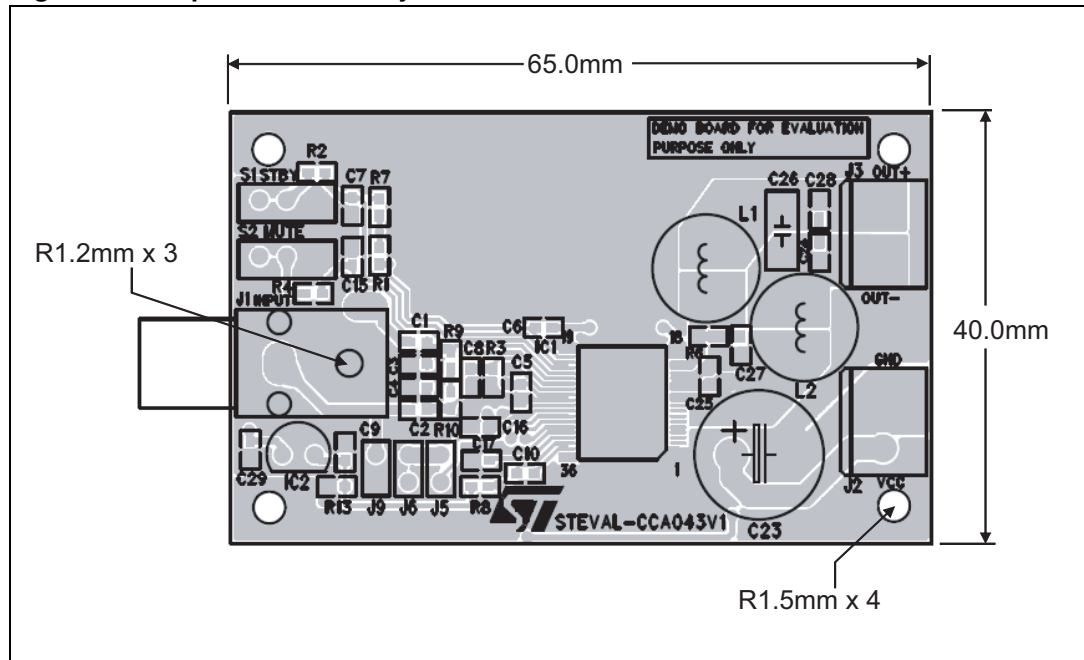

Figure 9. Top view of PCB layout - with dimensions



2.2 Design guidelines for PCB schematic and layout

2.2.1 Dumping network

The capacitor is mainly intended for high inductive loads and for common-mode noise attenuation.

Figure 10. Dumping network

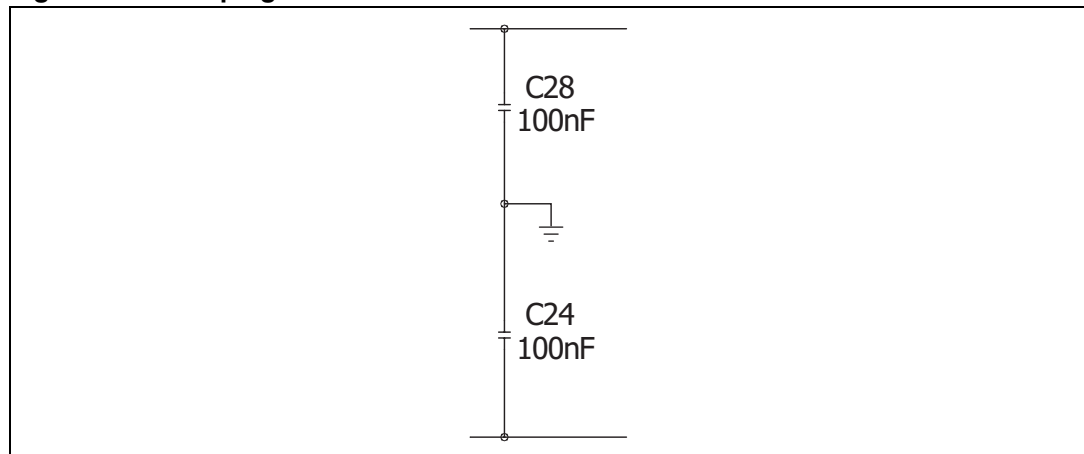

2.2.2 Main filter

The main filter is an LC Butterworth based filter. The cutoff frequency must be chosen between the upper limit of the audio band (~20 kHz) and the carrier frequency (310 kHz).

Figure 11. Main filter

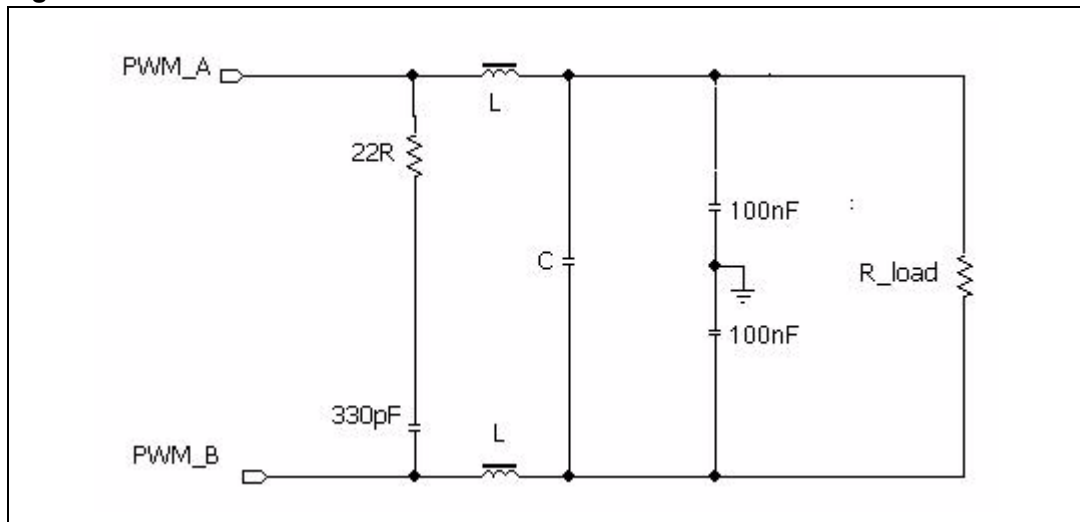

Table 6. Recommended values

R_{LOAD}	8 Ω	6 Ω
L_{LOAD}	33 μH	22 μH
C_{LOAD}	220 nF	220 nF

2.2.3 Layout recommendations

The following figures illustrate layout recommendations.

Solder the 100 nF bypass capacitor (X7R) as close as possible to the IC V_{CC} pins (recommended distance to be within 3 mm) in order to avoid spikes generated by the stray inductance caused by the copper supply lines.

Figure 12. Capacitor soldered as close as possible to V_{CC} pins

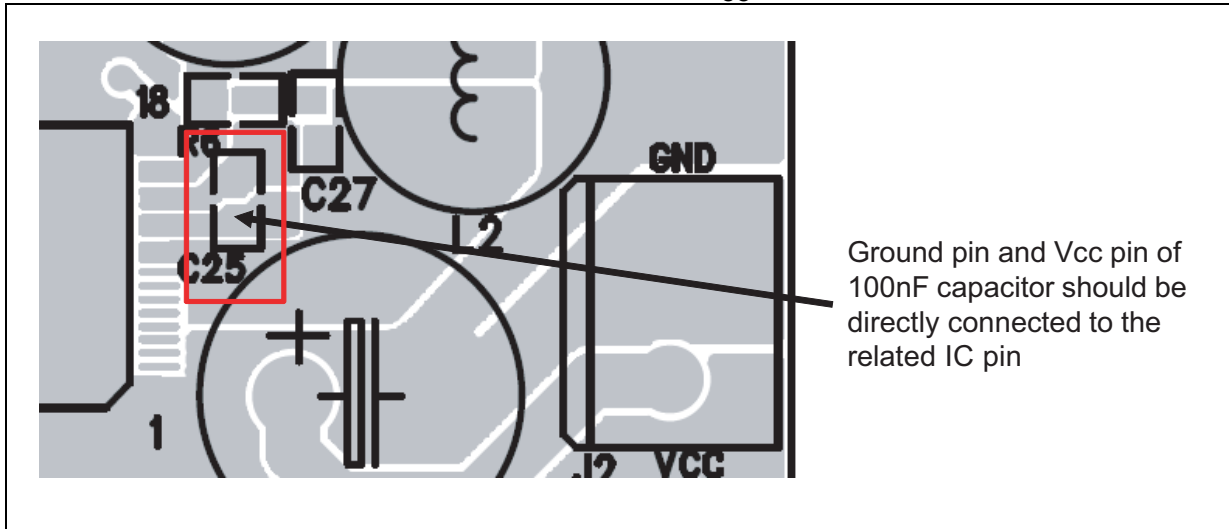

Solder the snubber network as close as possible to the related IC pin.

A voltage spike dangerous for device operation could occur if the snubber network is far from the output pins. It is recommended that the distance between the snubber network and the output pins be within 5 mm.

Figure 13. Snubber network soldered as close as possible to relevant IC pin

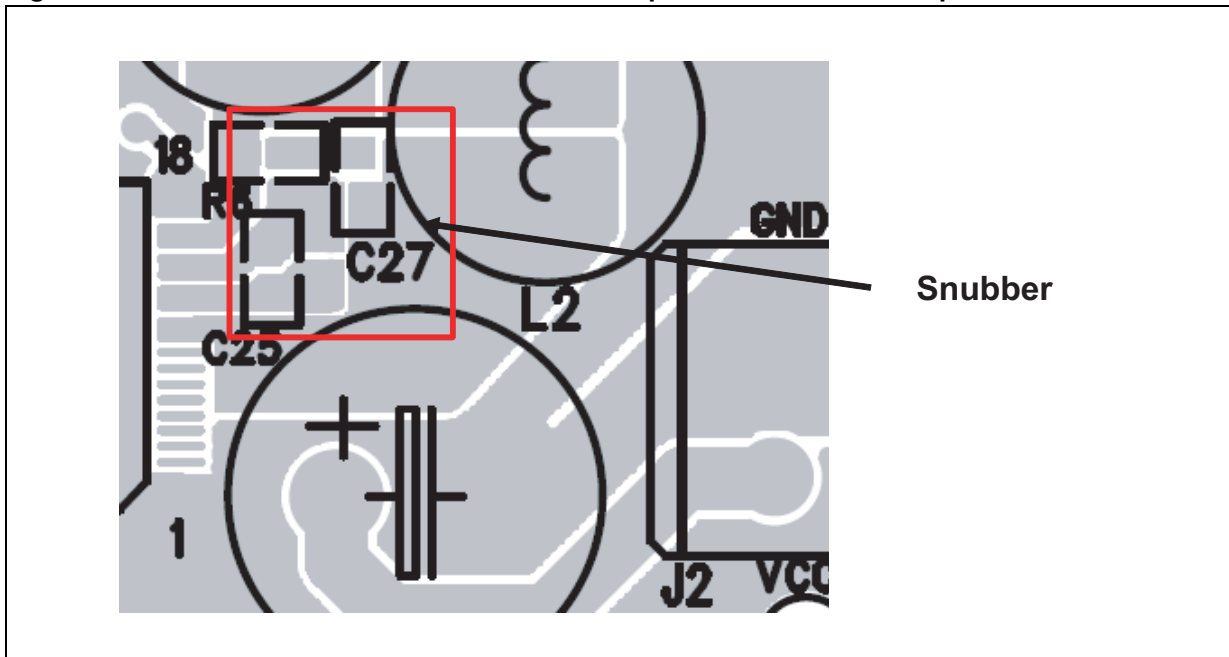

Place the RC filter for the ROOSC pin close to the IC.

Figure 14. RC filter

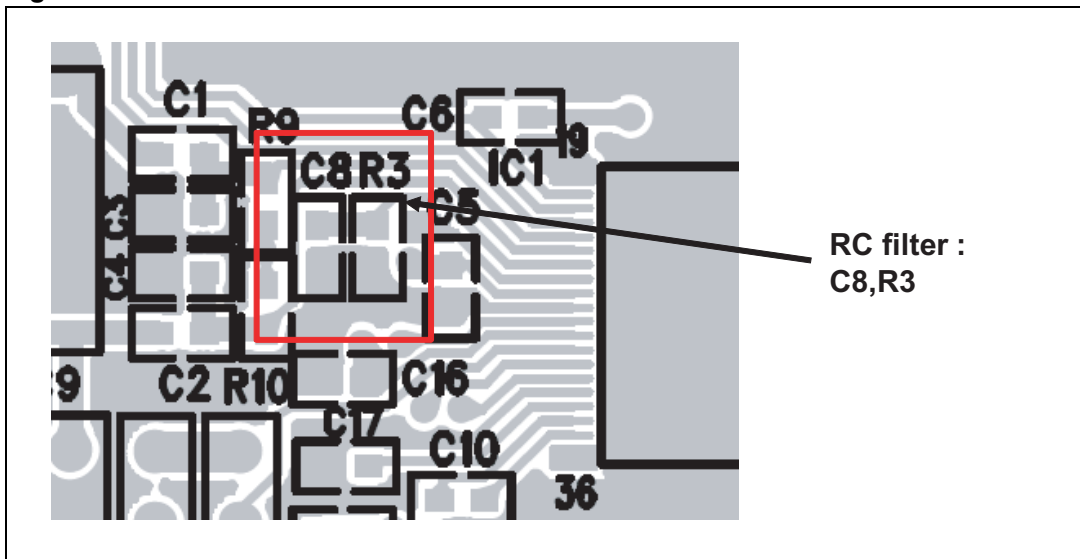

Place the filter capacitor for SVR, VREF, SVCC, VSS and VDDPW close to the IC.

Figure 15. Filter capacitor

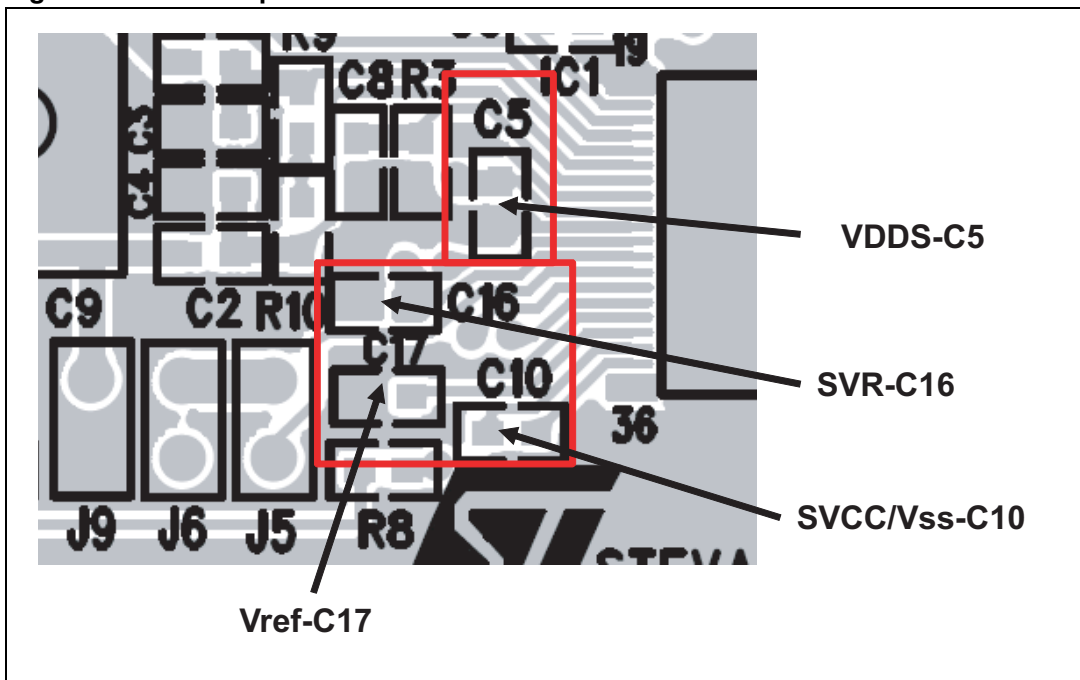

3 Revision history

Table 7. Document revision history

Date	Revision	Changes
13-Nov-2012	1	Initial release.

Please Read Carefully:

Information in this document is provided solely in connection with ST products. STMicroelectronics NV and its subsidiaries ("ST") reserve the right to make changes, corrections, modifications or improvements, to this document, and the products and services described herein at any time, without notice.

All ST products are sold pursuant to ST's terms and conditions of sale.

Purchasers are solely responsible for the choice, selection and use of the ST products and services described herein, and ST assumes no liability whatsoever relating to the choice, selection or use of the ST products and services described herein.

No license, express or implied, by estoppel or otherwise, to any intellectual property rights is granted under this document. If any part of this document refers to any third party products or services it shall not be deemed a license grant by ST for the use of such third party products or services, or any intellectual property contained therein or considered as a warranty covering the use in any manner whatsoever of such third party products or services or any intellectual property contained therein.

UNLESS OTHERWISE SET FORTH IN ST'S TERMS AND CONDITIONS OF SALE ST DISCLAIMS ANY EXPRESS OR IMPLIED WARRANTY WITH RESPECT TO THE USE AND/OR SALE OF ST PRODUCTS INCLUDING WITHOUT LIMITATION IMPLIED WARRANTIES OF MERCHANTABILITY, FITNESS FOR A PARTICULAR PURPOSE (AND THEIR EQUIVALENTS UNDER THE LAWS OF ANY JURISDICTION), OR INFRINGEMENT OF ANY PATENT, COPYRIGHT OR OTHER INTELLECTUAL PROPERTY RIGHT.

UNLESS EXPRESSLY APPROVED IN WRITING BY TWO AUTHORIZED ST REPRESENTATIVES, ST PRODUCTS ARE NOT RECOMMENDED, AUTHORIZED OR WARRANTED FOR USE IN MILITARY, AIR CRAFT, SPACE, LIFE SAVING, OR LIFE SUSTAINING APPLICATIONS, NOR IN PRODUCTS OR SYSTEMS WHERE FAILURE OR MALFUNCTION MAY RESULT IN PERSONAL INJURY, DEATH, OR SEVERE PROPERTY OR ENVIRONMENTAL DAMAGE. ST PRODUCTS WHICH ARE NOT SPECIFIED AS "AUTOMOTIVE GRADE" MAY ONLY BE USED IN AUTOMOTIVE APPLICATIONS AT USER'S OWN RISK.

Resale of ST products with provisions different from the statements and/or technical features set forth in this document shall immediately void any warranty granted by ST for the ST product or service described herein and shall not create or extend in any manner whatsoever, any liability of ST.

ST and the ST logo are trademarks or registered trademarks of ST in various countries.

Information in this document supersedes and replaces all information previously supplied.

The ST logo is a registered trademark of STMicroelectronics. All other names are the property of their respective owners.

© 2012 STMicroelectronics - All rights reserved

STMicroelectronics group of companies

Australia - Belgium - Brazil - Canada - China - Czech Republic - Finland - France - Germany - Hong Kong - India - Israel - Italy - Japan - Malaysia - Malta - Morocco - Philippines - Singapore - Spain - Sweden - Switzerland - United Kingdom - United States of America

www.st.com