

High voltage switching diode

BAS21C2

Description

High voltage switching diode encapsulated in a SOD-523 small plastic SMD package.

Features

- Fast switching speed
- Low forward voltage drop
- Small plastic SMD package
- Pb-free lead plating package

Mechanical Data

- Case: Molded Plastic, JEDEC SOD-523.
- Terminals: Solder plated, solderable per MIL-STD-750 Method 2026
- Polarity: Indicated by cathode band.
- Mounting Position : Any.

Symbol

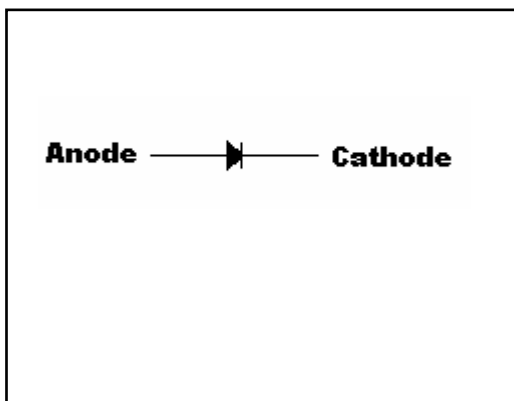

Outline

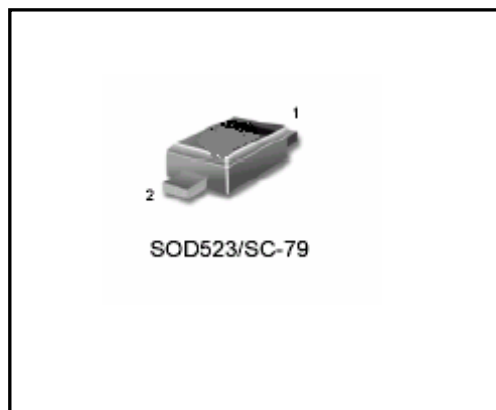



Absolute Maximum Ratings (TA=25°C, unless otherwise noted)

Parameters	Conditions	Symbol	Min	Typ	Max	Units
Repetitive peak reverse voltage		VRRM			300	V
RMS voltage		VRMS			210	V
Continuous reverse voltage		VR			300	V
Continuous forward current		IF			250	mA
Repetitive peak forward current	tp=1ms, duty≤0.25	IFRM			1	A
Non-repetitive peak forward current	t=1μs	IFSM			4.5	A
Total Device Dissipation	TA=25°C (Note 1)	PD			250	mW
	TSP≤90°C (Note 2)				500	
Thermal resistance	Junction to ambient (Note 1)	RθJA			500	°C/W
	Junction to soldering point (Note3)	RθJSP			120	
Storage temperature range		Tstg	-65		150	°C
Operating junction temperature range		Tj	-55		150	°C

- Note : 1.Parts mounted on FR-5 board with minimum pad, in free air.
- 2.Tsp is the solder point temperature at the soldering point of the cathode tab.
- 3.Soldering point of cathode tab.

Characteristics (Ta=25°C)

Characteristic	Symbol	Condition	Min.	Max.	Unit
Reverse Breakdown Voltage	VBR	IR=100μA	300	-	V
Forward Voltage (Note)	VF(1)	IF=100mA	-	1	V
	VF(2)	IF=200mA	-	1.25	V
Reverse Leakage Current (Note)	IR(1)	VR=250V,Tj=25°C	-	150	nA
	IR(2)	VR=250V,Tj=150°C		100	μA
Diode Capacitance	CD	VR=0V, f=1MHz	-	5	pF
Reverse Recovery Time	trr	IF=IR=30mA RL=100Ω measured at IR=3mA	-	50	ns

Notes: Pulse test, tp=300μs, duty cycle<2%.

Ordering Information

Device	Package	Shipping
BAS21C2-0-T5-G	SOD-523 (Pb-free lead plating and halogen-free package)	8000 pcs / Tape & Reel

Typical Characteristics

Forward Current vs Forward Voltage

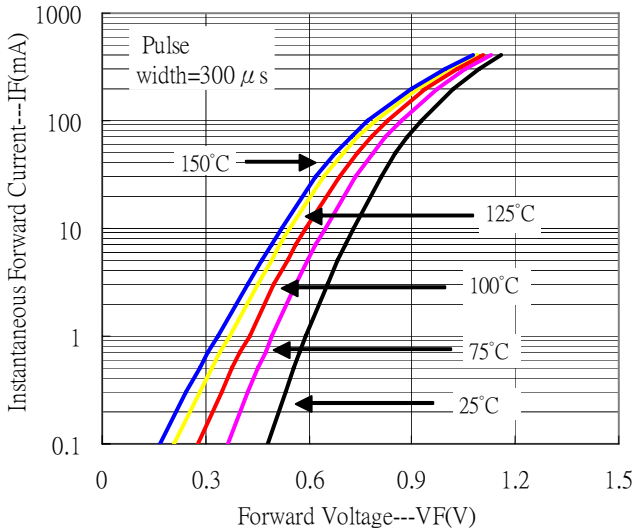

Reverse Leakage Current vs Reverse Voltage

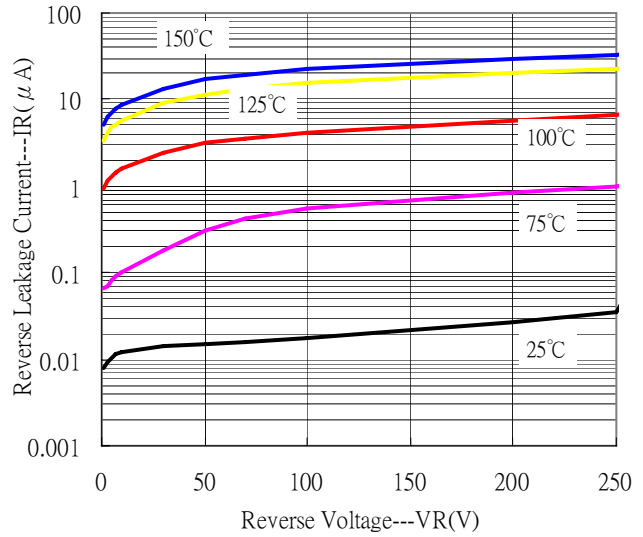

Junction Capacitance vs Reverse Voltage

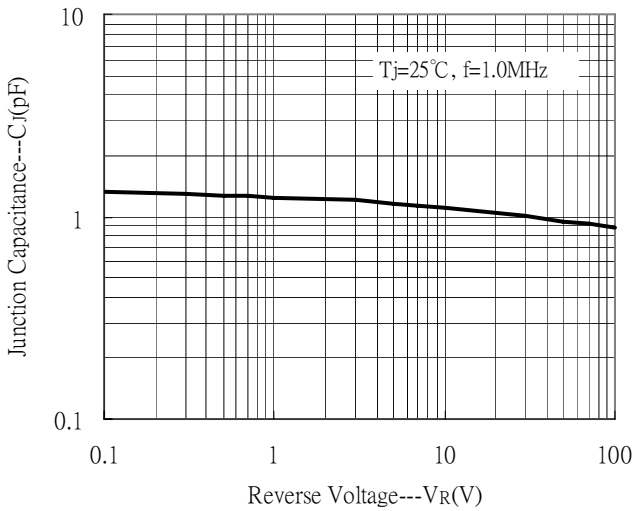

Power Derating Curve

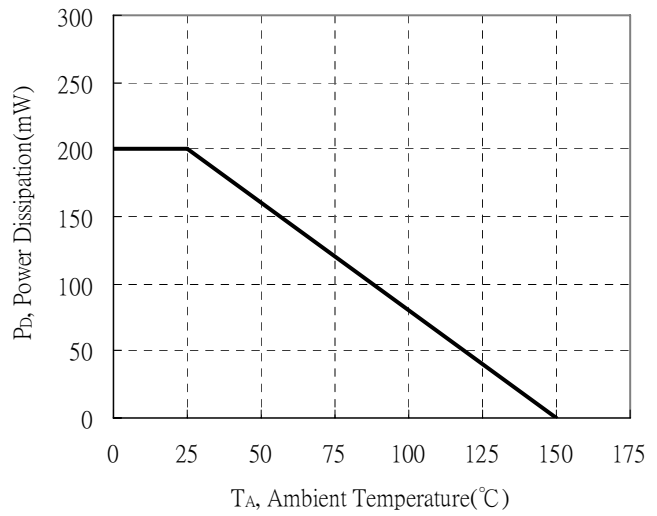

Recommended Footprint

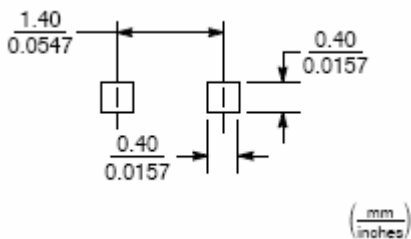

Reel Dimension

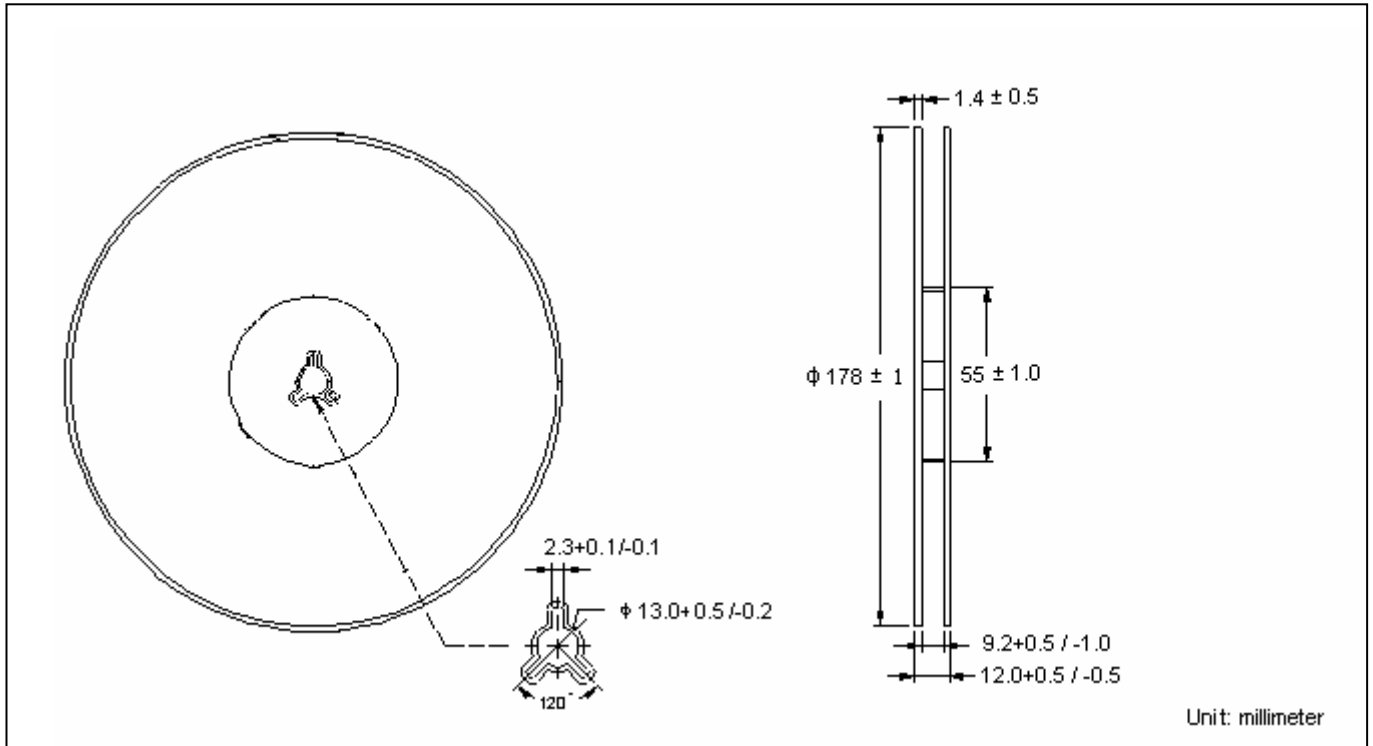

Carrier Tape Dimension

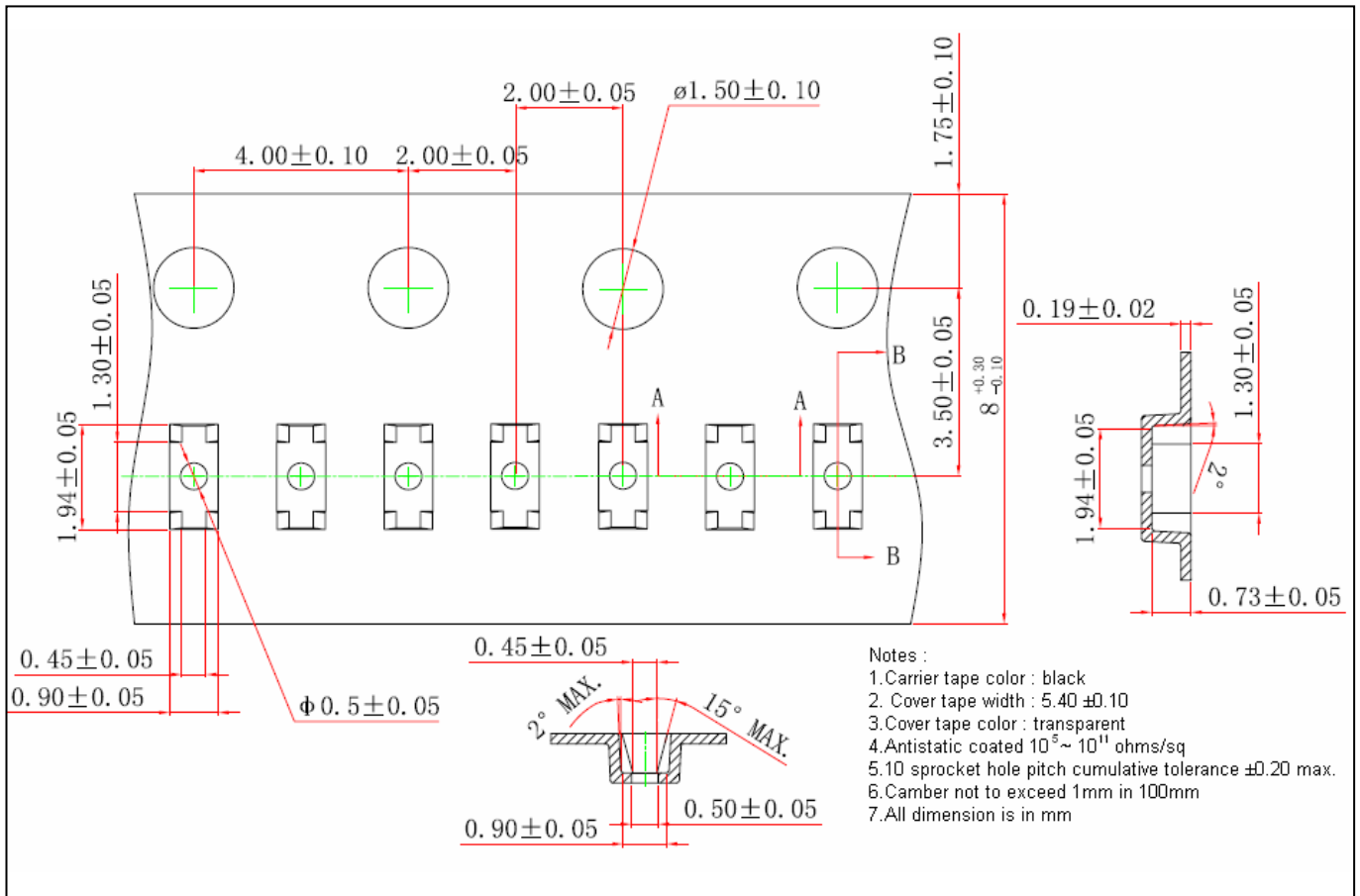

Recommended wave soldering condition

Product	Peak Temperature	Soldering Time
Pb-free devices	260 +0/-5 °C	5 +1/-1 seconds

Recommended temperature profile for IR reflow

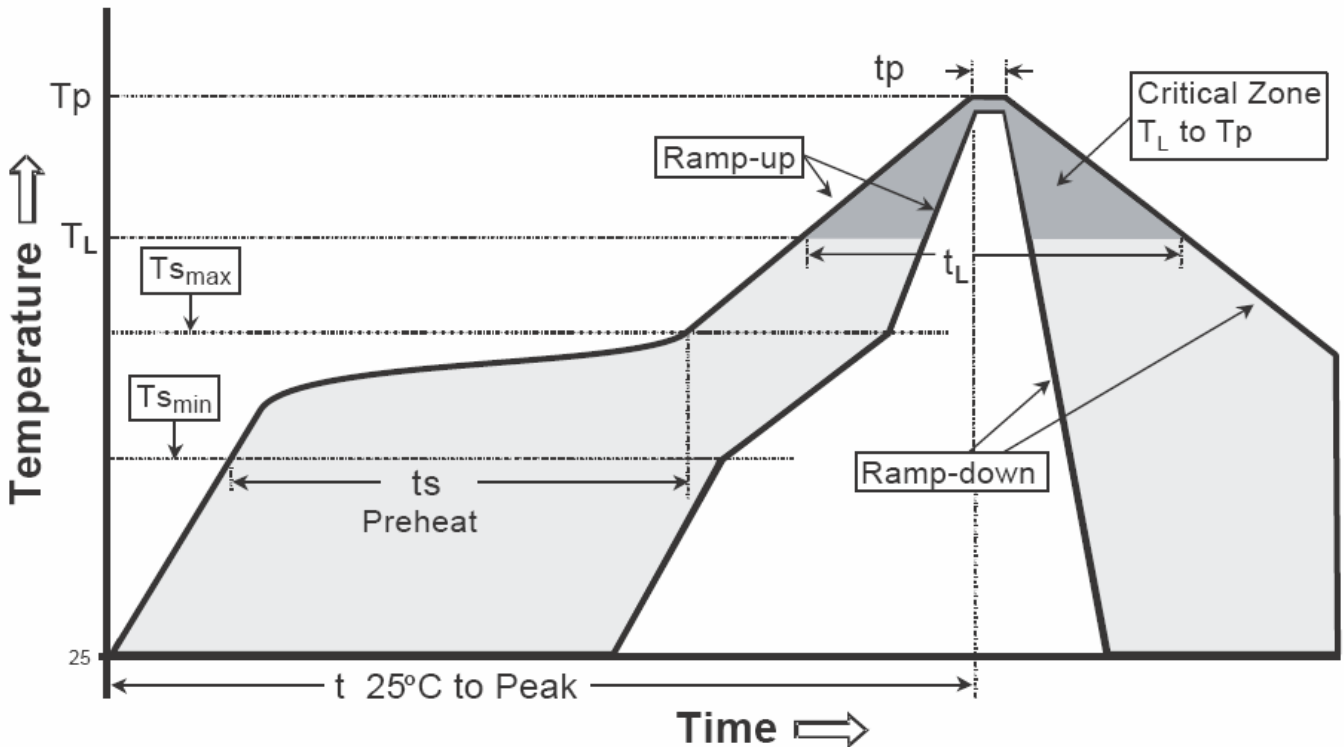

Profile feature	Sn-Pb eutectic Assembly	Pb-free Assembly
Average ramp-up rate (T _{smax} to T _p)	3°C/second max.	3°C/second max.
Preheat		
-Temperature Min(T _{s min})	100°C	150°C
-Temperature Max(T _{s max})	150°C	200°C
-Time(t _{s min} to t _{s max})	60-120 seconds	60-180 seconds
Time maintained above:		
-Temperature (T _L)	183°C	217°C
- Time (t _L)	60-150 seconds	60-150 seconds
Peak Temperature(T _P)	240 +0/-5 °C	260 +0/-5 °C
Time within 5°C of actual peak temperature(tp)	10-30 seconds	20-40 seconds
Ramp down rate	6°C/second max.	6°C/second max.
Time 25 °C to peak temperature	6 minutes max.	8 minutes max.

Note : All temperatures refer to topside of the package, measured on the package body surface.

SOD-523 Dimension

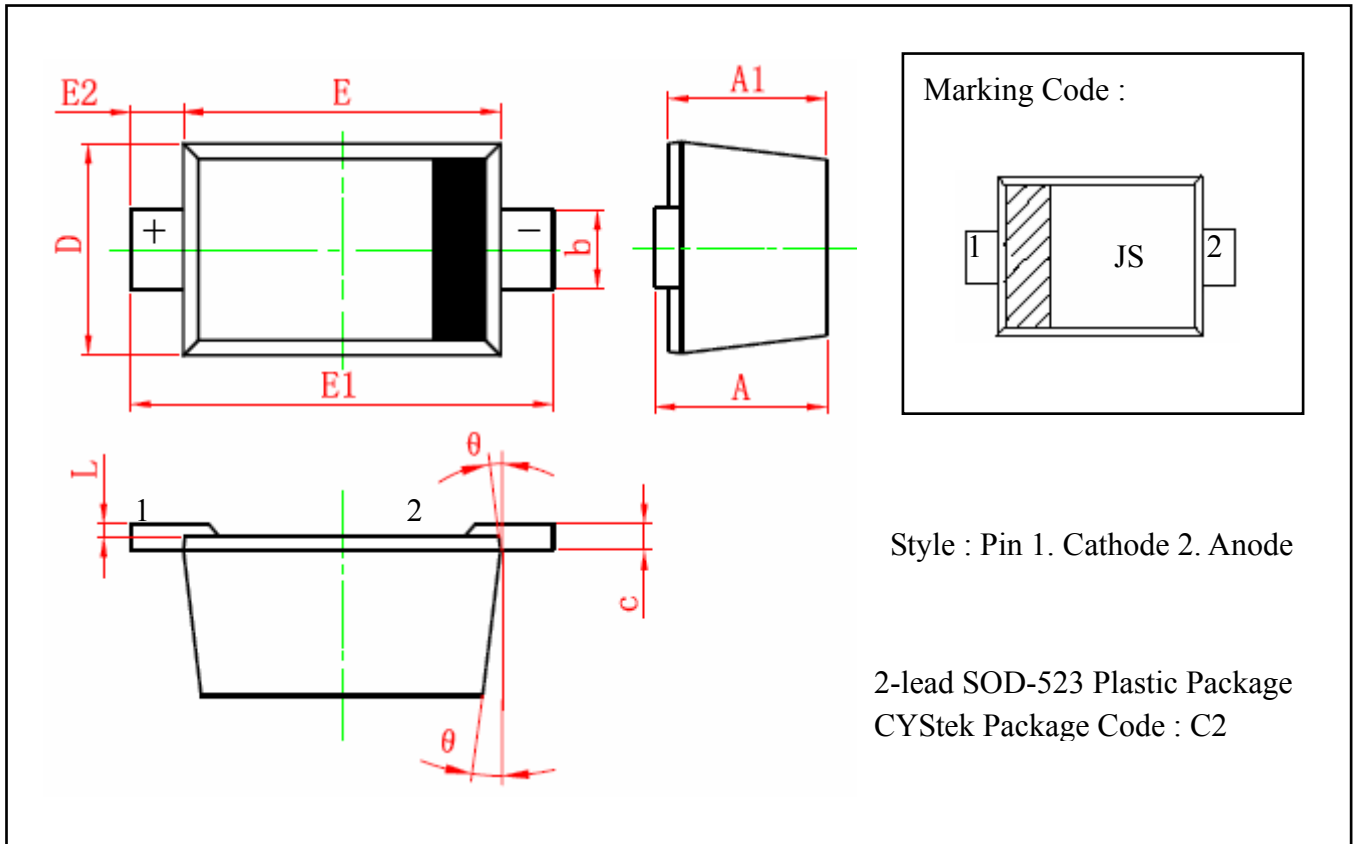

*: Typical

DIM	Millimeters		Inches		DIM	Millimeters		Inches	
	Min.	Max.	Min.	Max.		Min.	Max.	Min.	Max.
A	0.510	0.770	0.020	0.031	E	1.100	1.300	0.043	0.051
A1	0.500	0.700	0.020	0.028	E1	1.500	1.700	0.059	0.067
b	0.250	0.350	0.010	0.014	E2	0.200	REF	0.008	REF
c	0.080	0.150	0.003	0.006	L	0.010	0.070	0.001	0.003
D	0.750	0.850	0.030	0.033	θ	7° REF		7° REF	

Notes: 1.Maximum lead thickness includes lead finish thickness, and minimum lead thickness is the minimum thickness of base material.
 2.If there is any question with packing specification or packing method, please contact your local CYStek sales office.

Material:

- Lead: Pure tin plated.
- Mold Compound: Epoxy resin family, flammability solid burning class: UL94V-0.

Important Notice:

- All rights are reserved. Reproduction in whole or in part is prohibited without the prior written approval of CYStek.
- CYStek reserves the right to make changes to its products without notice.
- CYStek **semiconductor products are not warranted to be suitable for use in Life-Support Applications, or systems.**
- CYStek assumes no liability for any consequence of customer product design, infringement of patents, or application assistance.