

TO-126 (SOT-32) Plastic Package

CSD794, CSD794A

CSD794, 794A NPN PLASTIC POWER TRANSISTOR

Complementary CSB744, 744A

Audio frequency Power Amplifier

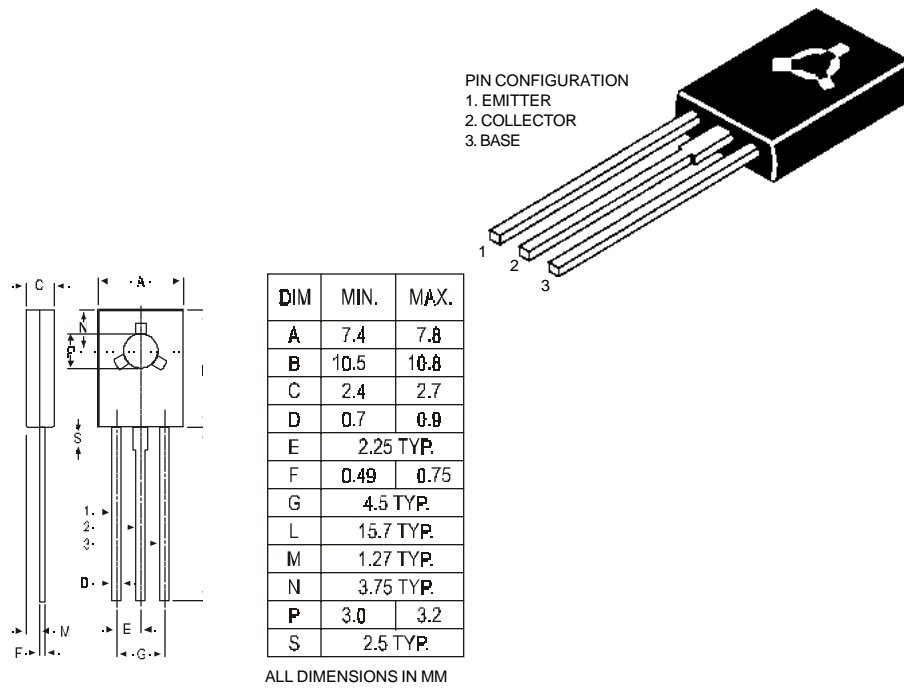

ABSOLUTE MAXIMUM RATINGS

		794	794A
Collector-base voltage (open emitter)	V_{CBO}	max. 70	70 V
Collector-emitter voltage (open base)	V_{CEO}	max. 45	60 V
Collector current (DC)	I_C	max.	3.0 A
Total power dissipation up to $T_C = 25^\circ C$	P_{tot}	max.	10 W
Junction temperature	T_j	max.	150 $^\circ C$
Collector-emitter saturation voltage $I_C = 1.5A; I_B = 0.15 A$	V_{CEsat}	max.	2.0 V
D.C. current gain $I_C = 0.5 A; V_{CE} = 5 V$	h_{FE}	min.	60
		max.	320

RATINGS (at $T_A=25^\circ C$ unless otherwise specified)

Limiting values

		794	794A
Collector-base voltage (open emitter)	V_{CBO}	max. 70	70 V
Collector-emitter voltage (open base)	V_{CEO}	max. 45	60 V

CSD794, CSD794A

Emitter-base voltage (open collector)	V_{EBO}	max.	5.0	V
Collector current (DC)	I_C	max.	3.0	A
Collector current (Pulse) (1)	I_C	max.	5.0	A
Base current (DC)	I_B	max.	0.6	A
Total power dissipation up to $T_C = 25^\circ\text{C}$	P_{tot}	max.	10	W
Total power dissipation up to $T_A = 25^\circ\text{C}$	P_{tot}	max.	1.0	W
Junction temperature	T_j	max.	150	$^\circ\text{C}$
Storage temperature	T_{stg}		-65 to +150	$^\circ\text{C}$

CHARACTERISTICS

$T_{amb} = 25^\circ\text{C}$ unless otherwise specified

			794	794A
Collector cutoff current				
$I_E = 0; V_{CB} = 45\text{V}$	I_{CBO}	max.	1.0	μA
Emitter cut-off current				
$I_C = 0; V_{EB} = 3\text{V}$	I_{EBO}	max.	1.0	μA
Breakdown voltages				
$I_C = 1\text{ mA}; I_B = 0$	V_{CEO}	min.	45	60 V
$I_C = 1\text{ mA}; I_E = 0$	V_{CBO}	min.	70	70 V
$I_E = 1\text{ mA}; I_C = 0$	V_{EBO}	min.	5.0	V
Saturation voltages				
$I_C = 1.5\text{ A}; I_B = 0.15\text{ A}$	V_{CEsat}^*	max.	2.0	V
	V_{BEsat}^*	max.	2.0	V
D.C. current gain				
$I_C = 20\text{ mA}; V_{CE} = 5\text{ V}^*$	h_{FE}^*	min.	30	
$I_C = 0.5\text{ A}; V_{CE} = 5\text{ V}^{**}$	h_{FE}^*	min.	60	
		max.	320	
Output capacitance at $f = 1\text{ MHz}$				
$I_E = 0, V_{CB} = 10\text{V}$	C_o	typ.	40	pF
Transition frequency				
$I_C = 0.1\text{ A}; V_{CE} = 5\text{ V}$	f_T	typ.	60	MHz

* Pulse test: Pulse width $\leq 350\ \mu\text{s}$; duty cycle $\leq 2\%$. Pulsed.

(1) $P_W \leq 10\text{ ms}$, Duty cycle $\leq 50\%$.

** h_{FE} classification: **R: 60-120 O: 100-200 Y: 160-320**

Disclaimer

The product information and the selection guides facilitate selection of the CDIL's Discrete Semiconductor Device(s) best suited for application in your product(s) as per your requirement. It is recommended that you completely review our Data Sheet(s) so as to confirm that the Device(s) meet functionality parameters for your application. The information furnished on the CDIL Web Site/ CD are believed to be accurate and reliable. CDIL however, does not assume responsibility for inaccuracies or incomplete information. Furthermore, CDIL does not assume liability whatsoever, arising out of the application or use of any CDIL product; neither does it convey any license under its patent rights nor rights of others. These products are not designed for use in life saving/support appliances or systems. CDIL customers selling these products (either as individual Discrete Semiconductor Devices or incorporated in their end products), in any life saving/support appliances or systems or applications do so at their own risk and CDIL will not be responsible for any damages resulting from such sale(s).

CDIL strives for continuous improvement and reserves the right to change the specifications of its products without prior notice.



CDIL is a registered Trademark of
Continental Device India Limited

C-120 Naraina Industrial Area, New Delhi 110 028, India.
Telephone + 91-11-2579 6150, 5141 1112 Fax + 91-11-2579 5290, 5141 1119
email@cdil.com www.cdilsemi.com