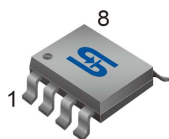

SOP-8EP

Pin Definition:

1. COMP	8. SS
2. FB	7. FREQ
3. EN	6. VCC
4. GND	5. LX

General Description

The TS1910A is a high performance, high efficiency step up DC-DC Converter with integrated 2A. The TS1910A converter input voltage ranging from 2.6 to 5.5V. The Output voltage can be set up to 27V. The selectable frequency of 680kHz and 1.2MHz allows the use of small external inductors and capacitors and provides fast transient response. Current mode control with external compensation network makes it easy to stabilize the system and keep maximum flexibility. Programmable soft start function minimizes impact on the input power system. Internal power MOSFET with very low $R_{DS(ON)}$ provides high efficiency. The TS1910A automatically transits from PWM to PFM during light load condition further increasing efficiency. The converter also provides protection functions such as Current Limit and Thermal shutdown.

Features

- 2.6V to 5.5V operating input voltage range
- Adjustable output voltage range up to 27V
- Up to 3A output switch current
- 680K/1.2MHz Selectable Switching Frequency
- Programmable soft-start function
- External Compensation Network
- Current limit and Thermal shutdown protection
- Under voltage Lockout
- $\leq 1\mu A$ Shutdown Current

Application

- Digital Still Cameras
- Portable Electronics
- PDA's and Palm-Top Computers
- Local Boost Regulator

Ordering Information

Part No.	Package	Packing
TS1910ACS RLG	SOP-8EP	2.5Kpcs / 13" Reel

Note: "G" denotes for Halogen Free

Absolute Maximum Rating

Parameter	Symbol	Limit	Unit
VCC Pin Voltage	V_{CC}	GND - 0.3 to GND + 6	V
EN, FREQ, COMP, FB, SS, Pin Voltage		GND - 0.3 to $V_{CC} + 0.3$	V
LX Pin Voltage	V_{LX}	30	V
Power Dissipation	PD	$(T_J - T_A) / \theta_{JA}$	mW
Storage Temperature Range	T_{ST}	-65 to +150	°C
Operating Junction Temperature Range	T_{OP}	-40 to +125	°C
Thermal Resistance from Junction to case	θ_{JC}	15	°C/W
Thermal Resistance from Junction to ambient	θ_{JA}	40	°C/W

Note: θ_{JA} is measured with the PCB copper area of approximately 1.5 in²(Multi-layer). That copper area needs connect to exposed pad.

Electrical Specifications ($T_a = 25^\circ\text{C}$, $V_{IN}=5\text{V}$, $EN=V_{IN}$, $I_L=0\text{A}$ unless otherwise noted)

Characteristics	Symbol	Conditions	Min	Typ	Max	Units
Input Voltage range	V_{CC}		2.6	--	5.5	V
Under Voltage Lockout	UVLO	Rising	--	2.35	2.6	V
UVLO Hysteresis	UVLOhys		--	-150	--	mV
Step-Up Voltage Adjust Range	V_{OUT}		$V_{CC}+0.5$	--	27	V
Operating quiescent current	I_{CCQ}	$I_{OUT}=0\text{mA}$, $V_{FB}=1.5\text{V}$	--	150	250	μA
Shutdown current	I_{SD}	$V_{EN}=0\text{V}$	--	0.1	1	μA
Feedback Voltage	V_{FB}		1.219	1.238	1.257	V
FB Input Leakage Current	I_{FB-LKG}	$V_{FB} = 1.5\text{V}$	-100	0.01	+100	nA
Line Regulation	REG_{LINE}	$V_{IN}=2.6$ to 5.5V $I_{OUT}=20\text{mA}$	--	0.2	--	%
Load Regulation	REG_{LOAD}	$V_{IN}=5\text{V}$ $I_{OUT}=1\text{mA}$ to 0.7A	-	0.3	--	%
Oscillator frequency	F_{OSC}	FREQ=High	900	1200	1500	KHz
		FREQ=Low	500	680	850	
FREQ high-level input voltage	V_{FQ-IH}		2	--	--	V
FREQ low-level input voltage	V_{FQ-IL}		--	--	0.5	
FREQ input leakage current	I_{FQ-LKG}	FREQ=GND	--	--	0.1	μA
Soft Start Current	I_{SS}		4	7	13	μA
N-channel MOSFET current limit	I_{LIM}	Duty=40%	3	3.8	-	A
MOSFET on-resistance (Note)	$R_{DS(on)}$	$V_{IN}=3\text{V}$, $I_{SW}=2\text{A}$	--	200	280	m Ω
		$V_{IN}=5\text{V}$, $I_{SW}=2\text{A}$	--	160	220	
EN high-level input voltage	V_{IH}		1.0	--	--	V
EN low-level input voltage	V_{IL}		--	-	0.4	V
EN Hysteresis	ENhys		--	200	-	mV
EN input leakage current	I_{EN-LKG}	$V_{EN}=GND$ or V_{IN}	--	0.01	0.1	μA
Maximum Duty Cycle	Duty	$V_{FB}=0\text{V}$	85	90	--	%
LX Leakage Current	I_{LXL}	$V_{LX}=25\text{V}$, $V_{FB}=1.5\text{V}$	--	--	10	μA
Thermal Shutdown	TSD		--	150	--	$^\circ\text{C}$
Thermal Shutdown Hysteresis	Thys		--	35	--	

Note: Guaranteed by design

Block Diagram

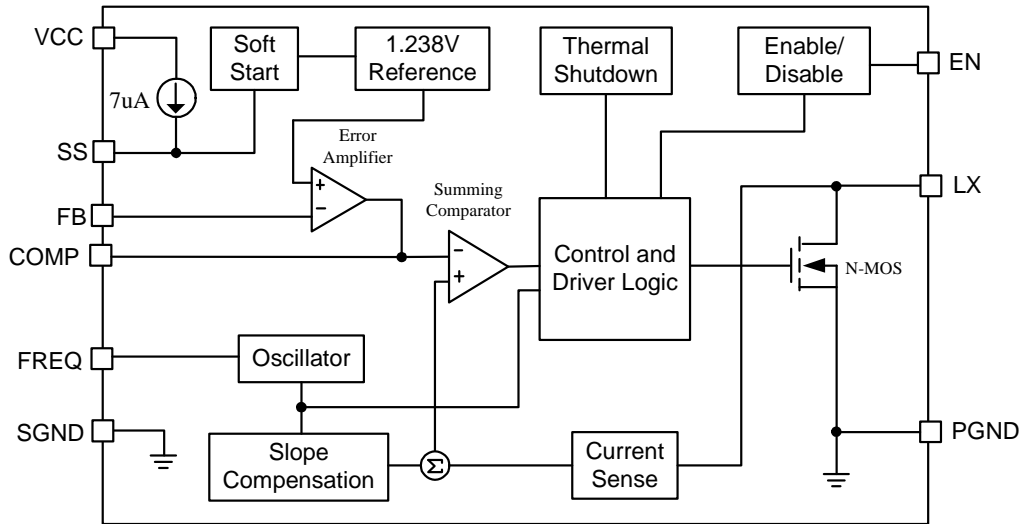

Pin Description

Pin Number	Pin Name	Description
1	COMP	Compensation Pin
2	FB	Feedback Pin
3	EN	Enable Pin
4	GND	Ground Pin
5	LX	Switch Output Pin
6	V _{CC}	Power Input pin
7	FREQ	Frequency select pin. The power switch operates at 680kHz if FREQ is connected to GND and at 1.2MHz if FREQ is connected to VCC
8	SS	Soft start Pin. Connect a capacitor to GND

Application Circuit

FREQ=High (Frequency=1.2MHz)

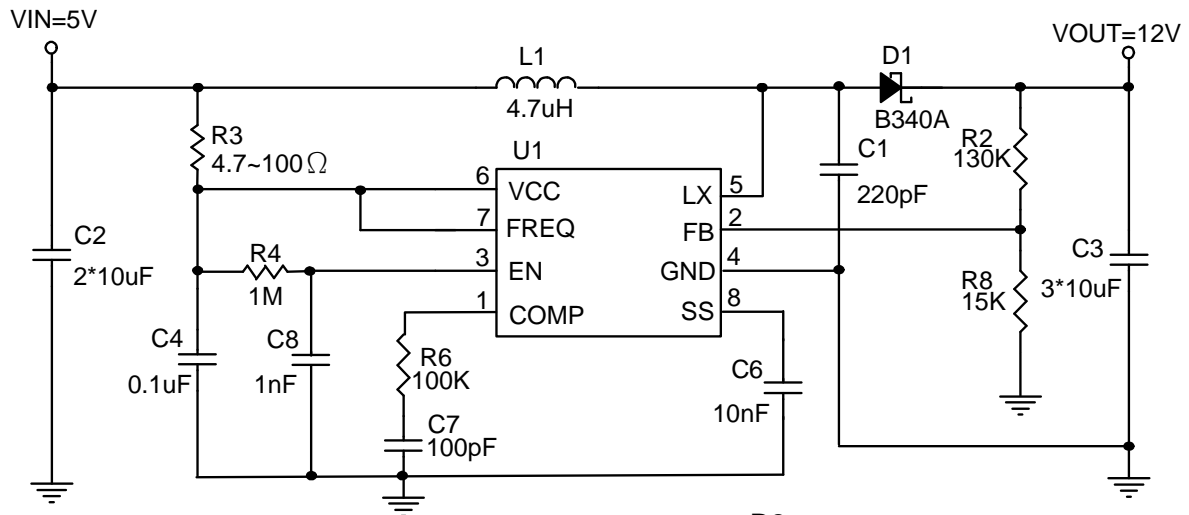

$$V_{OUT} = 1.238V \times \left(1 + \frac{R2}{R8}\right)$$

R8 Suggest 10K~30K

VIN ≤ 4.5V, R3=10Ω

VIN > 4.5V, R3=100Ω

FREQ=Low (Frequency=680KHz)

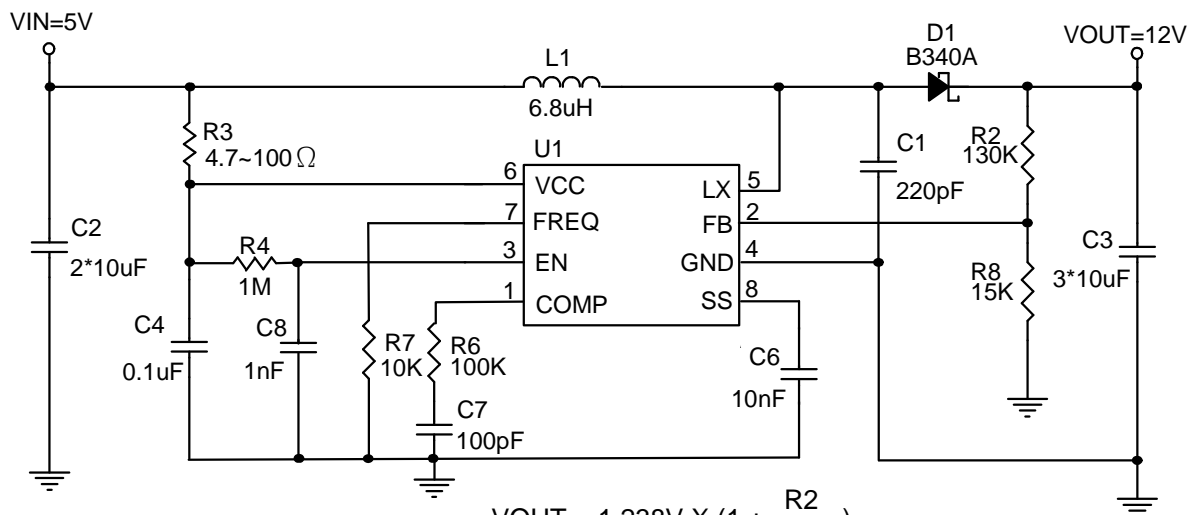

$$V_{OUT} = 1.238V \times \left(1 + \frac{R2}{R8}\right)$$

R8 Suggest 10K~30K

VIN ≤ 4.5V, R3=10Ω

VIN > 4.5V, R3=100Ω

Compensation Table

Frequency(Hz)	L1 (H)	VIN (V)	VOUT (V)	R6 (Ω)	C7 (F)
680K (FREQ=Low)	6.8u	2.5~4.4	5	10K	1.2n
		2.5~5.5	7	15K	470p
		2.5~5.5	9	27K	270p
		2.5~5.5	12	56K	150p
		2.5~5.5	15	150K	120p
		2.5~5.5	18	110K	100p
		2.5~5.5	21	150K	82p
		2.5~5.5	24	100K	47p
1.2M (FREQ=High)	4.7u	2.5~4.0	5	33K	1n
		2.5~5.5	7	39K	390p
		2.5~5.5	9	39K	220p
		2.5~5.5	12	100K	100p
		2.5~5.5	15	130K	68p
		2.5~5.5	18	150K	56p
		2.5~5.5	21	220K	47p
		2.5~5.5	24	390K	39p

Application Information

Setting the Output Voltage

Application circuit item shows the basic application circuit with TS1910A adjustable output version. The external resistor sets the output voltage according to the following equation:

$$V_{OUT}=1.238V \times (1+R2/R8)$$

For most applications, R8 is a suggested a value by 10~30KΩ. Place the resistor-divider as close to the IC as possible to reduce the noise sensitivity.

Soft Start Capacitor

The soft-start function begins from SS pin Voltage=0V to V_{CC} with a 7uA (typ.) constant current charging to the soft-start capacitor, so the capacitor should be large enough to let the output voltage reach regulation inside the soft-start cycle. Typical value of soft-start capacitor range is from 4.7nF to 100nF. After the cycle finished, the load can start to draw maximum current as required.

Frequency Select Pin (FREQ)

The frequency select pin FREQ allows to set the switching frequency of the device to 680 KHz (FREQ = low) or 1.2 MHz (FREQ = high). Higher switching frequency improves load transient response but reduces slightly the efficiency. The other benefits of higher switching frequency are a lower output ripple voltage. Usually, it is recommended to use 1.2 MHz switching frequency unless light load efficiency is a major concern.

Application Information (Continue)

Under Voltage Lockout (UVLO)

To avoid mis-operation of the device at low input voltages an under voltage lockout is included that disables the device, if the input voltage falls below (2.35V-150mV).

Input Capacitor Selection

For better input bypassing, low-ESR ceramic capacitors are recommended for performance. Two parallel 10uF (or one 22uF) input capacitor is sufficient for most applications. For a lower output power requirement application, this value can be decreased.

Output Capacitor Selection

For lower output voltage ripple, low-ESR output capacitor like ceramic capacitor is recommended. Three 10uF ceramic capacitors work for most of the applications. Higher capacitor values can be used to improve the load transient response and reduce output ripple.

Layout Guide

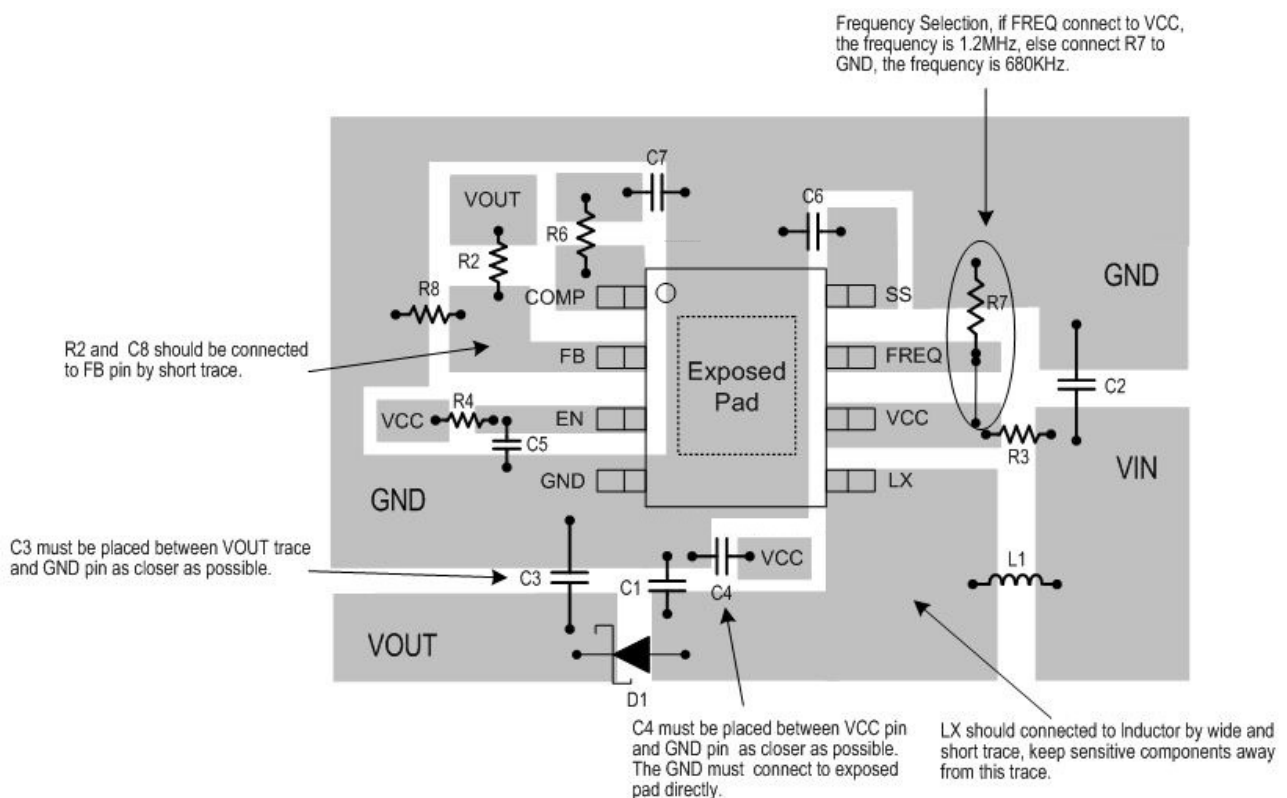

SOP-8EP Mechanical Drawing

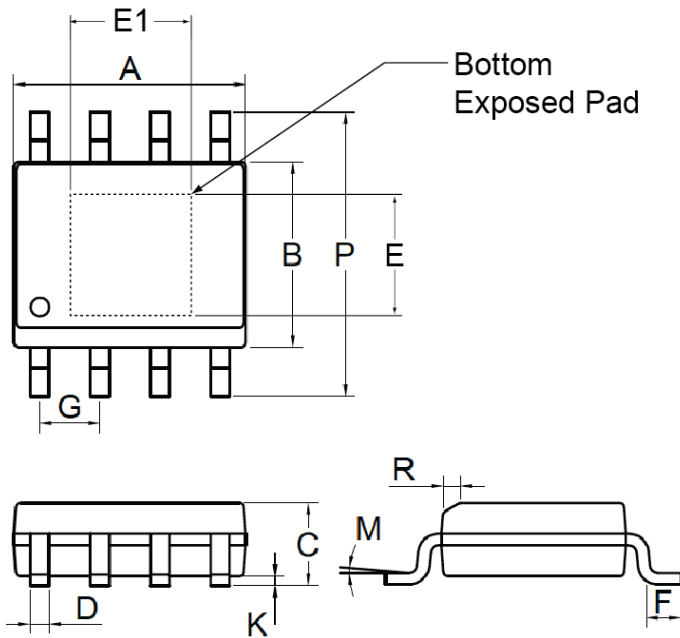

DIM	MILLIMETERS		INCHES	
	MIN	MAX	MIN	MAX.
A	4.80	5.00	0.189	0.196
B	3.80	4.00	0.150	0.157
C	1.35	1.75	0.054	0.068
D	0.35	0.49	0.014	0.019
E	2.05	2.41	0.081	0.095
E1	2.82	3.30	0.111	0.130
F	0.40	1.25	0.016	0.049
G	1.27BSC		0.05BSC	
K	0.10	0.25	0.004	0.009
M	0°	7°	0°	7°
P	5.80	6.20	0.229	0.244
R	0.25	0.50	0.010	0.019

Notice

Specifications of the products displayed herein are subject to change without notice. TSC or anyone on its behalf, assumes no responsibility or liability for any errors or inaccuracies.

Information contained herein is intended to provide a product description only. No license, express or implied, to any intellectual property rights is granted by this document. Except as provided in TSC's terms and conditions of sale for such products, TSC assumes no liability whatsoever, and disclaims any express or implied warranty, relating to sale and/or use of TSC products including liability or warranties relating to fitness for a particular purpose, merchantability, or infringement of any patent, copyright, or other intellectual property right.

The products shown herein are not designed for use in medical, life-saving, or life-sustaining applications. Customers using or selling these products for use in such applications do so at their own risk and agree to fully indemnify TSC for any damages resulting from such improper use or sale.