

SmartHCF™-USB Modem

Host-Controlled, V.90/K56flex™ Modem Device Set with USB Interface Device (11247), Modem Data Pump (P9373), SmartDAA™ (20463), and Optional Voice Codec (20437) for USB Applications

The Conexant™ SmartHCF-USB Host-Controlled, V.90/K56flex Modem Device Family with SmartDAA technology supports analog data up to 56 kbps, analog fax to 14.4 kbps, telephone answering machine (TAM), speakerphone (optional), world-wide, and Universal Serial Bus (USB) interface operation. The modem operates with PSTN telephone lines world-wide. Table 1 lists the available models.

Conexant's SmartDAA technology (patent pending) eliminates the need for a costly line transformer, relays, and opto-isolators typically used in discrete DAA (Data Access Arrangement) implementations. The SmartDAA architecture also simplifies product implementation by eliminating the need for country-specific board configurations enabling world-wide homologation of a single modem board design.

The SmartDAA system-powered DAA operates reliably without drawing power from the line, unlike line-powered DAAs which operate poorly when line current is insufficient due to long lines or poor line conditions. Enhanced features, such as monitoring of local extension status without going off-hook, are also supported.

Incorporating Conexant's proprietary Digital Isolation Barrier (DIB) design (patent pending) and other innovative DAA features, the SmartDAA architecture simplifies application design, minimizes layout area, and reduces component cost.

For over a decade, Conexant has assisted customers with DAA technology and homologation. This expertise and system level approach has been leveraged in this product.

The SmartHCF-USB device set, consisting of a USB Interface Device (UID) in a 64-pin TQFP, a Modem Data Pump (MDP) in a 100-pin TQFP, and a Line Side Device (LSD) (SmartDAA device) in a 32-pin TQFP, supports data/fax/TAM operation with hardware-based digital signal processing and DAA/telephone line interface functions (Figure 1). The optional Voice Codec (VC), in a 32-pin TQFP, supports full-duplex speakerphone (FDSP) operation with interfaces to a microphone and speaker (S model). Figure 2 identifies the major hardware signal interfaces.

Distinguishing Features

- V.90 data/V.17 fax modem
- SmartDAA technology
 - Eliminates many costly traditional DAA discrete components
 - Reduces modem and DAA board footprint
 - Allows a single modem board design to be approved for world-wide shipments
 - Caller ID detection
 - Line-in-use detection
 - Remote hang-up detection
 - Extension off-hook detection
 - Call waiting detection
 - Digital PBX line protection
- Data/Fax/Voice call discrimination
- Hardware-based digital signal processor (DSP)
- Full-duplex speakerphone mode (S model)
- World-wide operation
- Industry standard communication commands
- USB features
 - Universal Serial Bus Specification Rev. 1.1 compliant
 - USB full speed (12 Mbps)
 - Suspend/Resume
 - Vendor specific descriptions
- Four LED driver outputs
- System compatibilities
 - Windows 98, Windows 2000
 - Microsoft PC 98 and PC 99 compliant
- V.80 synchronous access mode
- Thin packages support low profile designs

Applications

- USB external modems
- Single design USB worldwide modem

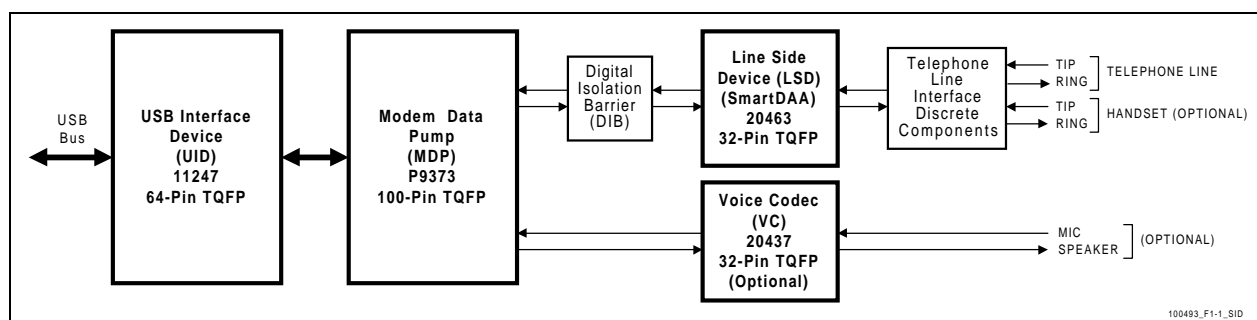

Figure 1. SmartHCF-USB Modem Simplified Interface Diagram

Table 1. SmartHCF-USB Modem Models and Functions

Model/Order/Part Numbers						Supported Functions	
Marketing Name	Device Set Order No.	USB Interface Device (UID) [64-TQFP] Part No.	Modem Data Pump (MDP) [100-TQFP] Part No.	Line Side Device (LSD) (SmartDAA) [32-Pin TQFP] Part No.	Voice Codec (VC) [32-Pin TQFP] Part No.	V.90/K56flex Data, V.17 Fax, TAM, World-Wide	FDSP
SmartHCF-USB	DS56-L511-001	11247-11	P9373-11	20463-11	—	Y	—
SmartHCF/S-USB	DS56-L511-011	11247-11	P9373-11	20463-11	20437-11	Y	Y

Notes:

1. Model options:

- S Full-duplex speakerphone (FDSP)
- USB Universal Serial Bus interface

2. Supported functions (Y = Supported; – = Not supported):

- TAM Telephone answering machine (Voice playback and record through telephone line)
- FDSP Full-duplex speakerphone and voice playback and record through telephone line and mic/speaker.

Information provided by Conexant Systems, Inc. is believed to be accurate and reliable. However, no responsibility is assumed by Conexant for its use, nor any infringement of patents, copyrights, or other rights of third parties which may result from its use. No license is granted by implication or otherwise under any patent rights or copyright of Conexant other than for circuitry embodied in Conexant products. Conexant reserves the right to change circuitry at any time without notice. This document is subject to change without notice.

Conexant products are not designed or intended for use in life support appliances, devices, or systems where malfunction of a Conexant product can reasonably be expected to result in personal injury or death. Conexant customers using or selling Conexant products for use in such applications do so at their own risk and agree to fully indemnify Conexant for any damages resulting from such improper use or sale.

K56flex is a trademark of Conexant Systems, Inc. and Lucent Technologies.

Conexant, the Conexant C symbol, "What's Next in Communications Technologies", SmartDAA, and SmartHCF are trademarks of Conexant Systems, Inc.

Product names or services listed in this publication are for identification purposes only, and may be trademarks or registered trademarks of third parties [their respective companies]. All other marks mentioned herein are the property of their respective [holders] owners.

©1999, Conexant Systems, Inc.
All Rights Reserved

Reader Response: Conexant strives to produce quality documentation and welcomes your feedback. Please send comments and suggestions to conexant.tech.pubs@conexant.com. For technical questions, contact your local Conexant sales office or field applications engineer.

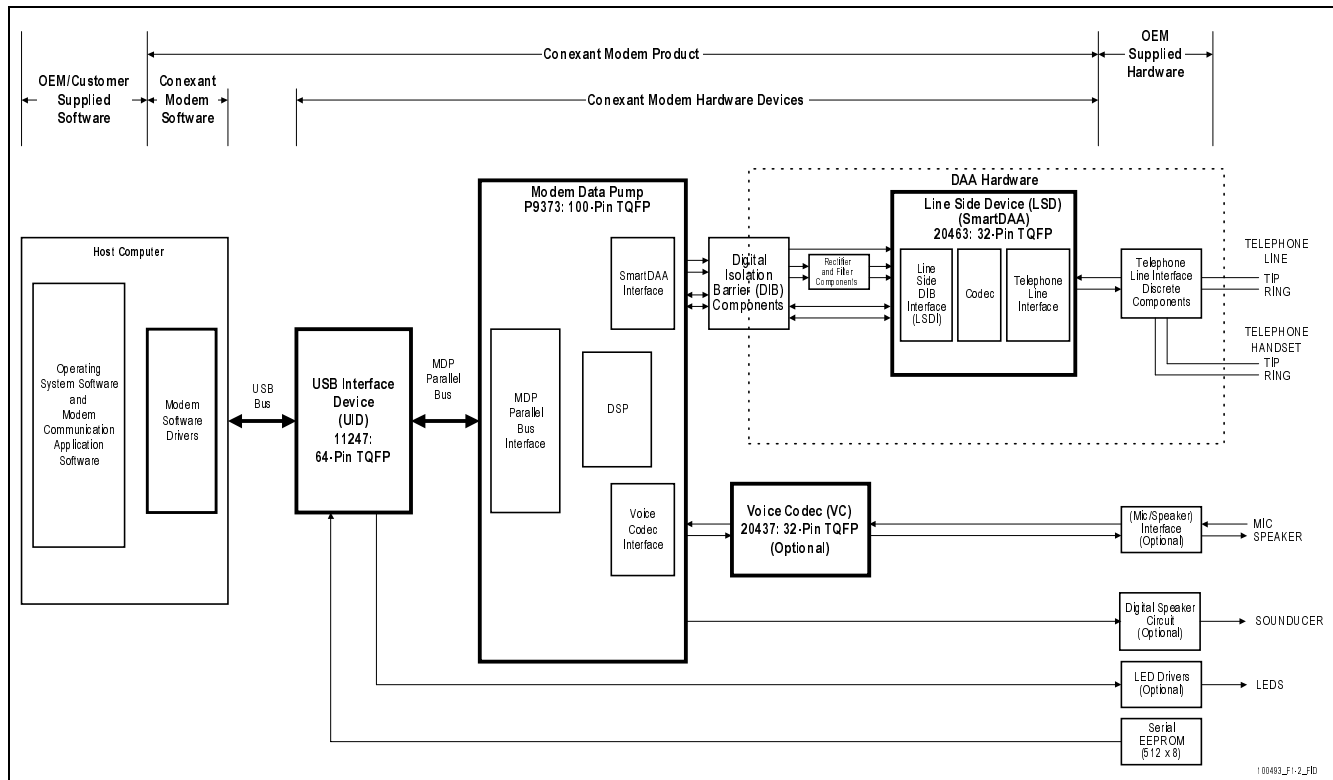

Figure 2. SmartHCF-USB Modem Major Interfaces

Overview

The Conexant SmartHCF-USB Host-Controlled, V.90/K56flex™ Modem Device Family with SmartDAA™ technology supports analog data up to 56 kbps, analog fax to 14.4 kbps, telephone answering machine (TAM), speakerphone (optional), world-class, and USB interface operation.

The modem operates with PSTN telephone lines world-wide. Modem driver software is provided.

The device set, consisting of a USB Interface Device (UID) in a 64-pin TQFP, a Modem Data Pump (MDP) in a 100-pin TQFP, and a Line Side Device (LSD) (SmartDAA device) in a 32-pin TQFP, supports data/fax/TAM operation with hardware-based digital signal processing and DAA/telephone line interface functions.

The optional Voice Codec (VC), in a 32-pin TQFP, supports full-duplex speakerphone (FDSP) operation with interfaces to a microphone and speaker (S model).

In V.90/K56flex data mode, the modem can receive data at line speeds up to 56 kbps from a digitally connected V.90 or K56flex-compatible central site modem. In this mode, the modem can transmit data at line speeds up to V.34 rates.

In V.34 data mode, the modem can operate at line speeds up to 33.6 kbps. When applicable, error correction (V.42/MNP 2-4) and data compression (V.42 bis/MNP 5) maximize data transfer integrity and boost average data throughput. Non-error-correcting mode is also supported.

In V.32 bis mode, the modem can operate at line speeds up to 14.4 kbps.

Fax Group 3 send and receive rates are supported up to 14.4 kbps with T.30 protocol.

V.80 synchronous access mode supports host-controlled communication protocols, e. g., H.324 video conferencing.

In TAM mode, 4-bit, 8-bit, or 16-bit per sample coding schemes at 8 kHz sample rates provide flexible format compatibility and allow efficient storage of voice/audio. This mode supports applications such as digital telephone answering machine (TAM), voice annotation, and recording from and playback to the telephone line.

Detailed Features

General Modem Features

- V.90 data modem with receive rates up to 56k bps and send rates up to V.34 rates
 - ITU-T V.90, K56flex, V.34 (33.6 kbps), V.32 bis, V.32, V.22 bis, V.22, V.23, and V.21; Bell 212A and 103
 - V.42 LAPM and MNP 2-4 error correction
 - V.42 bis and MNP 5 data compression
 - V.250 (ex V.25 ter) and V.251 (ex V.25 ter Annex A) commands

- V.17 fax modem with send and receive rates up to 14.4 kbps
 - V.17, V.29, V.27 ter, and V.21 ch 2
 - EIA/TIA 578 Class 1 and T.31 Class 1.0 commands
- Telephony/TAM
 - V.253 commands
 - 8-bit μ -Law/A-Law coding (G.711)
 - 8-bit/16-bit linear coding
 - 8 kHz sample rate
 - Concurrent DTMF, ring, and Caller ID detection
- V.80 synchronous access mode supports host-controlled communication protocols with H.324 interface support
- V.8/V.8bis and V.251 (ex V.25 ter Annex A) commands
- Data/Fax/Voice call discrimination
- Full-duplex Speakerphone (FDSP) Mode (S model)
 - Microphone and speaker interface
- Hardware-based digital signal processing
- Single configuration profile stored in host
- World-wide operation
 - Complies to TBR21 and other country requirements
 - Caller ID detection
- System compatibilities
 - Windows 98, Windows 2000 operating systems
 - Microsoft PC 98 and PC 99 Design Initiative compliant
 - Unimodem/V compliant
 - Pentium 200 MHz equivalent or greater
 - 16 Mbyte RAM or more
- Thin packages support low profile designs
 - UID (11247): 64-pin TQFP
 - MDP (P9373): 100-pin TQFP (1.2 mm max. height)
 - LSD (20463): 32-pin TQFP (1.6 mm max. height)
 - VC (20437): 32-pin TQFP (1.6 mm max. height)
- Four LED driver outputs

USB features

- Universal Serial Bus Specification Rev. 1.1 compliant
- USB full speed (12 Mbps)
- Suspend/Resume
- Vendor specific descriptions
- Bus-powered USB device

SmartDAA Features

- System side powered DAA operates under poor line current supply conditions
- Wake-on-ring
- Ring detection
- Line polarity reversal detection
- Line current loss detection
- Caller ID detection
- Pulse dialing
- Line-in-use detection – detects even while on-hook
- Remote hang-up detect – for efficient call termination
- Extension pickup detect
- Call waiting detection
- Digital PBX line protection
- Meets world-wide DC VI Masks requirements

Description

General

Modem operation, including dialing, call progress, telephone line interface, speakerphone interface, and host interface functions are supported and controlled through the V.250, V.251, and V.253-compatible command set.

The modem hardware connects to the host processor via a USB interface. The OEM adds a crystal circuit, EEPROM, DIB components, LSD power rectifier and filter components, telephone line interface, optional speakerphone interface, and other supporting discrete components as required by the modem model (Table 1) and the host modem software to complete the system.

Host Modem Software

The host modem software performs the following tasks:

1. General modem control, which includes command sets, fax class 1, fax class 1.0, TAM, speakerphone, error correction, data compression, voice sample formatting, operating system interface, and USB interface functions.
2. MDP control. Binary digital signal processor (DSP) executable code controlling MDP operation is downloaded as required during operation. (Signal processing, including data and facsimile modulation and demodulation, and linear voice sampling, is performed in the MDP hardware DSP.)
3. SmartDAA control, which includes MDP SmartDAA Interface control, LSD configuration and control, telephone line interface parameter control, and telephone line impedance control.

Configurations of the modem software are provided to support modem models listed in Table 1.

Binary executable host modem software is provided for the OEM.

Data/Fax Modes

In V.90/K56flex data modem mode, the modem can receive data from a digital source using a V.90- or K56flex-compatible central site modem at line speeds up to 56 kbps. Asymmetrical data transmission supports sending data at line speeds up to V.34 rates. This mode can fallback to full-duplex V.34 mode and to lower rates as dictated by line conditions.

In V.34 data modem mode, the modem can operate in 2-wire, full-duplex, asynchronous modes at line rates up to 33.6 kbps. Data modem modes perform complete handshake and data rate negotiations. Using V.34 modulation to optimize modem configuration for line conditions, the modem can connect at the highest data rate that the channel can support from 33600 bps down to 2400 bps with automatic fallback. Automode operation in V.34 is provided in accordance with PN3320 and in V.32 bis in accordance with PN2330. All tone and pattern

detection functions required by the applicable ITU or Bell standard are supported.

In V.32 bis data modem mode, the modem can operate at line speeds up to 14.4 kbps.

In fax modem mode, the modem can operate in 2-wire, half-duplex, synchronous modes and can support Group 3 facsimile send and receive speeds of 14400, 12000, 9600, 7200, 4800, and 2400 bps. Fax data transmission and reception performed by the modem are controlled and monitored through the EIA/TIA-578 Fax Class 1 and T.31 Fax Class 1.0 command interface. Full HDLC formatting, zero insertion/deletion, and CRC generation/checking are provided.

Synchronous Access Mode (SAM) - Video Conferencing

V.80 Synchronous Access Mode between the modem and the host/DTE is provided for host-controlled communication protocols, e.g., H.324 video conferencing applications.

World-wide Operation

The modem operates in TBR21-compliant and other countries. Country-dependent modem parameters for functions such as dialing, carrier transmit level, calling tone, call progress tone detection, answer tone detection, blacklisting, caller ID, and relay control are programmable.

SmartDAA technology allows a single PCB design and single BOM to be homologated world-wide. Advanced features such as extension pickup detection, remote hangup detection, line-in-use detection, and digital PBX detection are supported.

TAM Mode

TAM Mode features include:

- 8-bit μ -Law, A-Law, linear signed, and linear unsigned coding at 8 kHz sample rate
- 16-bit linear coding at 8 kHz sample rate
- ADPCM (4-bit IMA) coding at 8 kHz sample rate is also supported to meet Microsoft WHQL logo requirements allow efficient storage of voice/audio.

Full-duplex voice supports concurrent voice receive and transmit. Tone detection/generation, call discrimination, and concurrent DTMF detection are also supported.

TAM Mode is supported by three submodes:

1. Online Voice Command Mode supports connection to the telephone line.
2. Voice Receive Mode supports recording voice or audio data input from the telephone line or, for the S model, a microphone.
3. Voice Transmit Mode supports playback of voice or audio data to the telephone line or, for the S model, a speaker.

Speakerphone Mode (S Model)

The S model includes external microphone and speaker interfaces which support full-duplex speakerphone (FDSP) operation.

Hands-free full-duplex telephone operation is supported in Speakerphone Mode under host control. Speakerphone Mode features an advanced proprietary speakerphone algorithm which supports full-duplex voice conversation with acoustic, line, and handset echo cancellation. Parameters are constantly adjusted to maintain stability with automatic fallback from full-duplex to pseudo-duplex operation. The speakerphone algorithm allows position independent placement of microphone and speaker. The host can separately control volume, muting, and AGC in microphone and speaker channels.

Reference Design

A data/fax/TAM/speakerphone reference design for a USB card (RD00-D830) is available to minimize application design time and costs.

The card is pretested to pass FCC Part 15, Part 68, and TBR 21 for immediate manufacturing.

A design package is available in electronic form. The design package includes files for schematics, bill of materials (BOM), board layout (Gerber format), and documentation.

The design can also be used for the basis of a custom design by the OEM to accelerate design completion for rapid market entry.

Serial EEPROM Programming Utility

The OEM-supplied serial EEPROM is required to store the USB device, configuration, interface, and endpoint descriptors. A DOS-based EEPROM Programming Utility for the SmartHCF-USB product is available for the OEM to use to program the serial EEPROM with USB device, configuration, interface, and endpoint descriptors. The USB device descriptors (including Vendor ID, Product ID, Device Release Number, Manufacturer Name, Product Name, and Serial Number) can be customized as required.

Additional Information

Additional information is described in the SmartHCF-USB Modem Device Family for Desktop Applications Designer's Guide (Doc. No. 100493) and the Commands for Host-Processed and Host-Controlled Modems Reference Manual (Doc. No. 100498).

Hardware Description

SmartDAA™ technology (patent pending) eliminates the need for a costly analog transformer, relays, and opto-isolators that are typically used in discrete DAA implementations. The programmable SmartDAA architecture simplifies product implementation in world-

wide markets by eliminating the need for country-specific components.

USB Interface Device (UID)

The UID, packaged in a 64-pin TQFP, interfaces between a Universal Serial Bus and the MDP host parallel bus. The USB transceivers, PLL (phase locked loop), and voltage regulator (for MDP +3.3V) are integrated into the UID. The UID also supports suspend/wakeup, output ports for LED indicators, and an interface to serial EEPROM for storing vendor specific descriptors. The UID conforms to the USB Specification Rev. 1.1 and supports full-speed (12 Mbps) USB device implementation.

The UID derives +5 V power from the USB interface and provides +3.3 V power to the MDP. The input crystal frequency is 28.224 MHz.

Modem Data Pump (MDP)

The MDP performs telephone line signal modulation/demodulation in a hardware digital signal processor (DSP) which reduces computational load on the host processor. Downloadable architecture allows updating of MDP executable code.

The MDP, packaged in a 100-pin TQFP, includes a host parallel bus interface, a digital signal processor (DSP), a voice codec (VC) interface, and a SmartDAA Interface.

The MDP communicates with the UID via host parallel bus signals.

The SmartDAA Interface communicates with, and supplies power and clock to, the LSD through the DIB.

The input clock frequency is 28.224 MHz and is supplied by the UID. The operating voltage is +3.3 V with +5 V tolerant inputs.

In V.90/K56flex data modem mode, the MDP can receive data from a digital source using a V.90- or K56flex-compatible central site modem at line speeds up to 56 kbps. Asymmetrical data transmission supports sending data at speeds up to V.34 rates.

In V.34 data modem mode, the MDP can operate in 2-wire, full-duplex, synchronous/asynchronous modes at line rates up to 33.6 kbps. Using V.34 modulation to optimize modem configuration for line conditions, the MDP can connect at the highest data rate that the channel can support from 33.6 kbps to 300 bps with automatic fallback. Automode operation in V.34 is provided in accordance with PN3320 and in V.32 bis in accordance with PN2330.

In V.32 bis mode, the MDP can operate at line speeds up to 14.4 kbps.

In fax modem mode, the MDP supports Group 3 facsimile send and receive speeds of speeds of 14400, 12000, 9600, 7200, 4800, and 2400 bps.

Downloading of MDP code from the host modem software through the UID is supported.

Digital Isolation Barrier (DIB) (OEM Supplied)

The DIB electrically DC isolates the MDP from the LSD and telephone line. The MDP is connected to a fixed digital ground and operates with standard CMOS logic levels. The LSD is connected to a floating ground and can tolerate high voltage input (compatible with telephone line and typical surge requirements).

The DIB transformer couples power and clock from the MDP to the LSD.

The DIB data channel supports bidirectional half-duplex serial transfer of data, control, and status information between the MDP and the LSD.

SmartDAA Line Side Device (LSD)

The LSD includes a Line Side DIB Interface (LSDI), a coder/decoder (codec), and a Telephone Line Interface (TLI).

The LSDI communicates with, and receives power and clock from, the SmartDAA interface in the MDP through the DIB.

LSD power is received from the MDP PWRCLKP and PWRCLKN pins via the BID through a half-wave rectifying diode and capacitive power filter circuit connected to the DIB transformer secondary winding.

Information is transferred between the LSD and the MDP through the DIB_P and DIB_N pins. These pins connect to the MDP DIB_DATAP and DIB_DATAN pins, respectively, through the DIB.

The TLI integrates DAA and direct telephone line interface functions and connects directly to the line TIP and RING pins, as well as to external line protection components.

Direct LSD connection to TIP and RING allows real-time measurement of telephone line parameters, such as the telephone central office (CO) battery voltage, individual telephone line (copper wire) resistance, and allows dynamic regulation of the off-hook TIP and RING voltage and total current drawn from the central office (CO). This allows the modem to maintain compliance with U.S. and world-wide regulations and to actively control the DAA power dissipation.

Voice Codec (VC) (S Model)

The optional VC, packaged in a 32-pin TQFP, supports voice/full-duplex speakerphone (FDSP) operation with interfaces to a microphone and a speaker.

UID (11247) Hardware Pins and Signals**General**

The major functional application signals are summarized below.

UID Signal Interface and Pin Assignments

The UID hardware interface signals are shown by major interface in Figure 3 and are shown by pin number in Figure 4.

USB Interface

The USB interface complies with the Universal Serial Bus Specification Rev. 1.1.

The supported USB interface signals are:

- Data Plus (DP); input/output
- Data Minus (DM); input/output
- +5 V Power (USB_+5 V); input

LED Interface

The supported LED driver signals are:

- LED Indicator 0 (LEDS0); output. This output is used to indicate Power/Ready status.
- LED Indicator 1 (LEDS1); output. This output is used to indicate Carrier Detect status.
- LED Indicator 2 (LEDS2); output. This output is used to indicate Transmit/Receive Data status.
- LED Indicator 3 (LEDS3); output. This output is used to indicate Off-Hook status.

Serial EEPROM Interface

A serial EEPROM is required to store the USB device, configuration, interface, and endpoint descriptors. Device descriptors include Vendor ID, Product ID, Device Release Number, Manufacturer Name, Product Name, and Serial Number. Connection to a 4096 (512 x 8)-bit serial EEPROM rated at 2 MHz (EECLK is 1.5 MHz) is required. For example, the following EEPROMs or equivalent may be used: Microchip 93LC66A (512 x 8) and Atmel AT93C66 (512 x 8).

The EEPROM interface signals are:

- Serial Data Input (EEDI); output
- Serial Data Output (EEDO); input
- Clock (EECLK); output
- Chip Select (EECS); output

MDP Interface

MDP power, clock, address, data, and control signals are supported to power, control, and monitor MDP operation and to transfer data between the UID and the MDP.

The MDP interface signals are:

- +3.3 V MDP Power (VR_OUT); output
- Switch (SUSPEND_N); output
- 28.224 MHz Clock (OSCOUT); output
- Address Lines (XA[5:0]); output
- Data Lines (XD[7:0]), input/output
- Read Enable (XRD_N); output
- Write Enable (XWE_N); output
- MDP Interrupt Request (XIRQ); input
- MDP Reset (DP_RESET_N); output
- Wake Up Reset (WKRES#); output

DAA Interface

The supported DAA interface signals are:

- Ring Wakeup (RINGWAKE#); input
- Ring Indicator (IRING#); input

UID Signal Interface and Pin Assignments

The UID hardware interface signals are shown by major interface in Figure 3 and are shown by pin number in Figure 4.

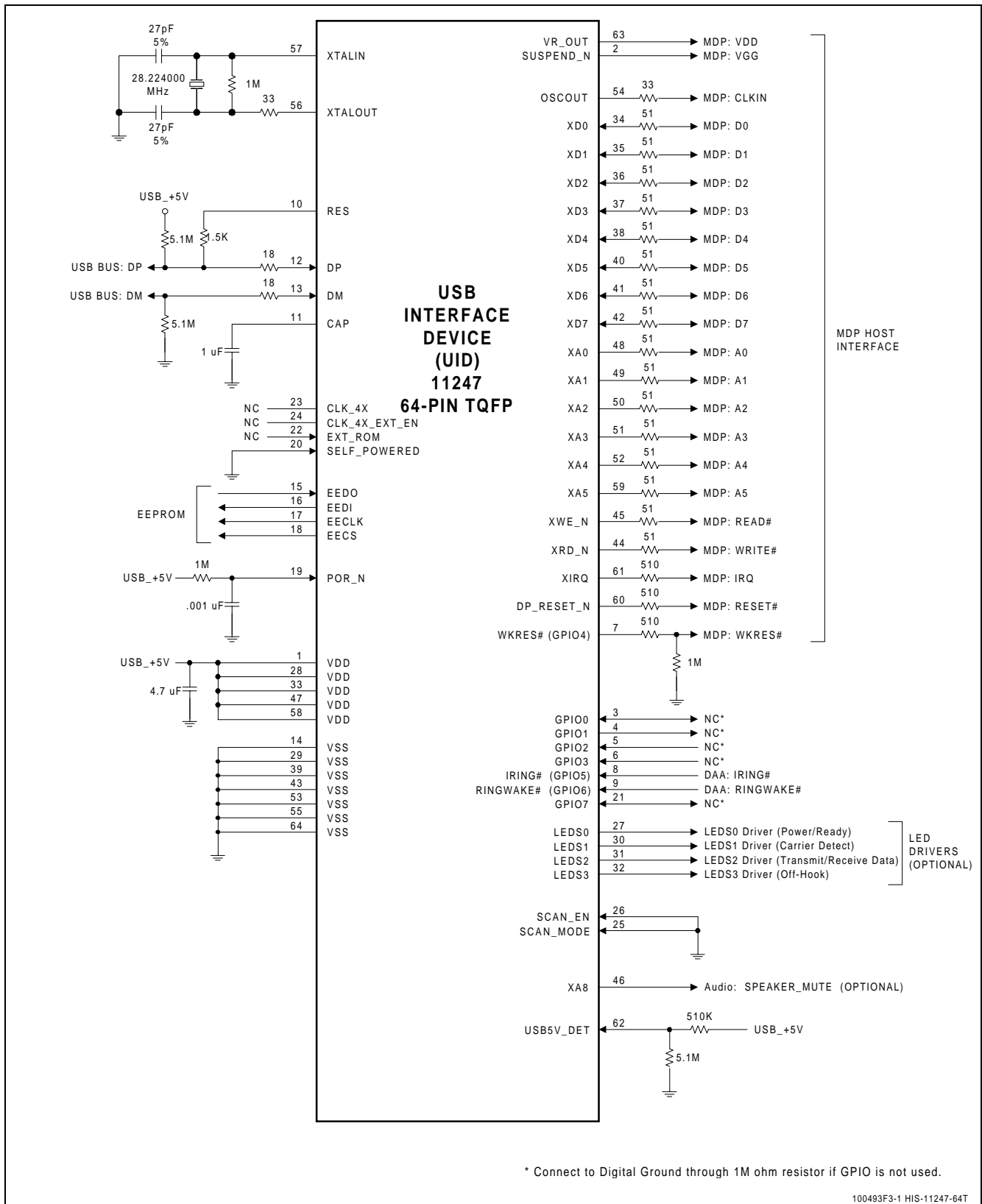

Figure 3. UID Hardware Interface Signals

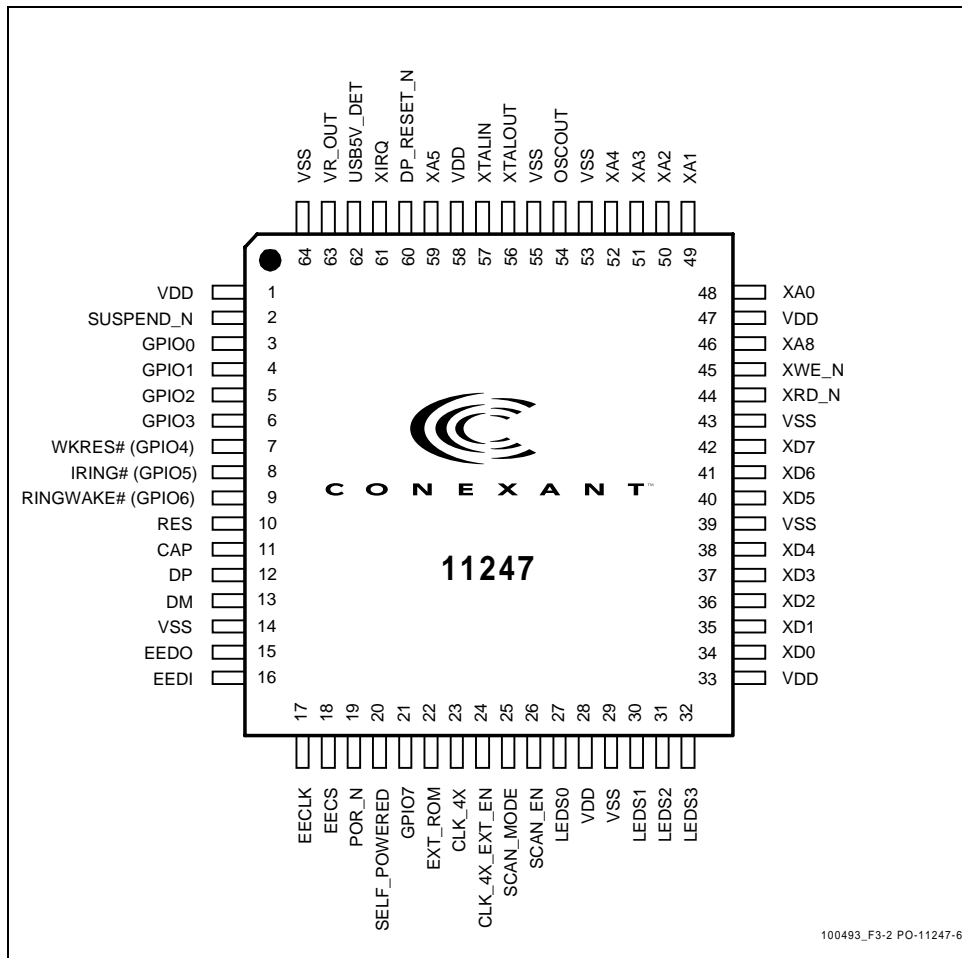

Figure 4. UID Pin Signals - 64-Pin TQFP

MDP (P9373) Hardware Pins and Signals

General

The major functional application signals are summarized below.

System Control and Status

The following discrete signals are used by the UID to control and monitor MDP operation:

- Wakeup Reset (WKRES#); input
- Interrupt Request for MDP Interface (IRQ); output
- Reset (RESET#); input
- Clock In (CLKIN); input

Digital Speaker Interface

The following output is used for audible call progress or carrier monitoring in Data/Fax mode only where sound quality is not important.

- Digital Speaker Output (DSPKOUT); output

Parallel Bus Interface

The parallel address, data, and control signals are:

- Address Lines (A[6:0]); input
- Data Lines (D[7:0]), input/output
- Chip Select (CS#); input
- Read Enable (READ#); input
- Write Enable (WRITE#); output

LSD Interface (Through DIB)

The DIB interface signals are:

- Clock and Power Positive (PWRCLKP); output
- Clock and Power Negative (PWRCLKN); output
- Data Positive (DIB_DATAP); input/output
- Data Negative (DIB_DATAN); input/output

VC Interface

The VC interface signals are:

- Sleep (IASLEEP); output
- Master Clock (M_CLK); output
- Voice Serial Clock (V_SCLK); input
- Voice Serial Control (V_CTRL); output
- Voice Serial Frame Sync (V_STROBE); input
- Voice Serial Transmit Data (V_TXSIN); output
- Voice Serial Receive Data (V_RXOUT); input

MDP Signal Interface and Pin Assignments

The MDP hardware interface signals are shown by major interface in Figure 5 and are shown by pin number in Figure 6.

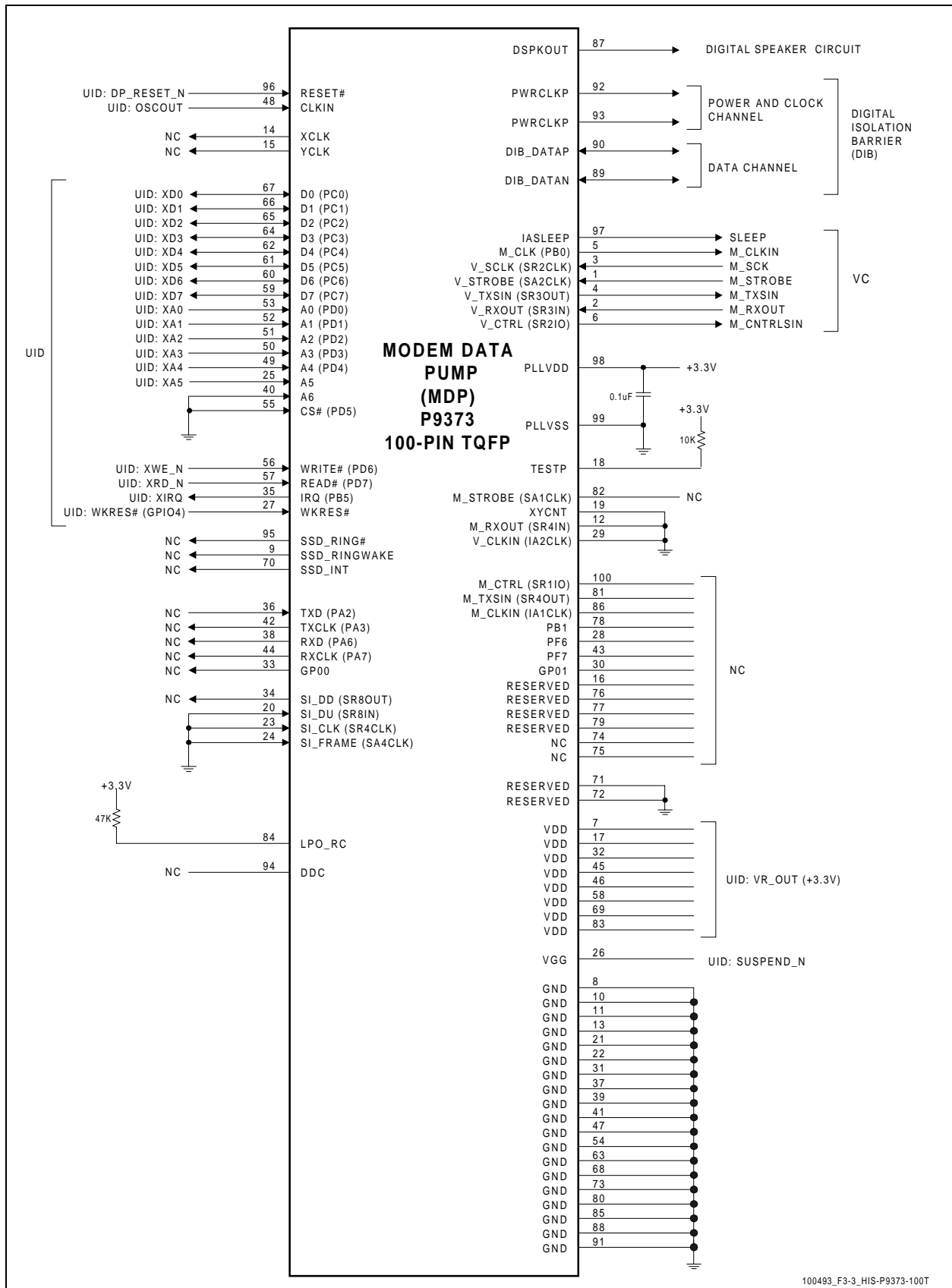

Figure 5. MDP (P9373) 100-Pin TQFP Hardware Interface Signals

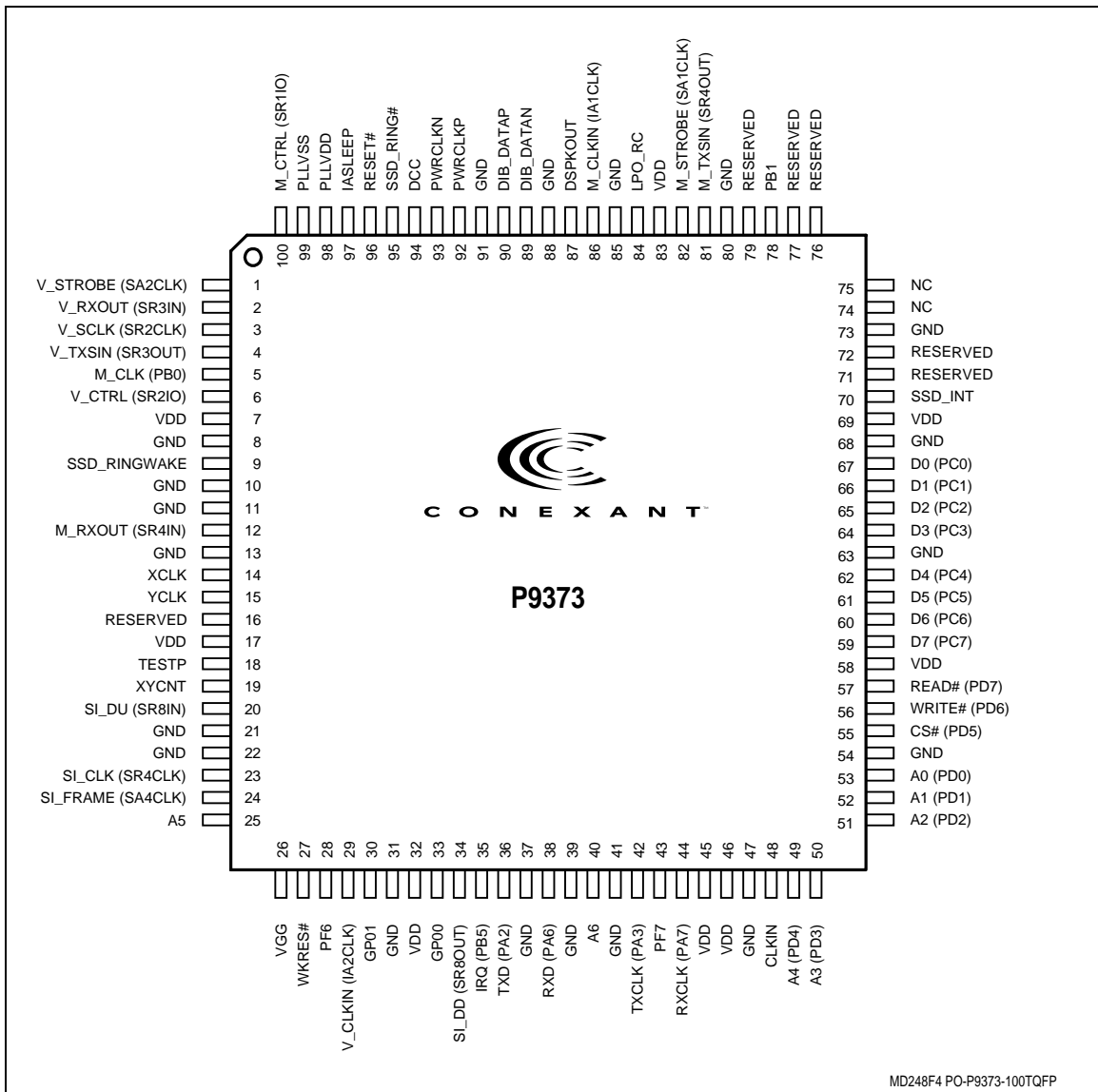

Figure 6. MDP (P9373) 100-Pin TQFP Pin Signals

SmartDAA LSD (20463) Hardware Pins and Signals

General

MDP Interface (Through DIB)

The DIB interface signals are:

- Clock (CLK); input
- Digital Power (DVDD); input power
- Digital Ground (DGND); digital ground
- Data Positive (DIB_P); input
- Data Negative (DIB_N); input

Telephone Line Interface

The telephone line interface signals are:

- RING AC Coupled (RAC1); input
- TIP AC Coupled (TAC1); input
- RING AC Coupled for Caller ID (RAC2); input
- TIP AC Coupled for Caller ID (TAC2); input
- Electronic Inductor Resistor (EIR); output
- TIP and RING DC Measurement (TRDC); input
- DAC Output Voltage (DAC); output
- Electronic Inductor Capacitor (EIC)
- Electronic Inductor Output (EIO)
- Electronic Inductor Feedback (EIF)
- Resistive Divider Midpoint (DCF)
- Transmit Analog Output (TXA); output
- Receive Analog Input (RXI); input
- Receiver Gain (RXG); output
- MOV Enable (MOVEN); output
- World-wide Impedance 0 (ZW0); input
- US Impedance 0 (ZUS0); input
- Transmit Feedback (TXF); input
- Transmit Output (TXO); output

LSD Interface Signals and Pin Assignments

The LSD (20463) 32-pin TQFP hardware interface signals are shown by major interface in Figure 7 and are shown by pin number in Figure 8.

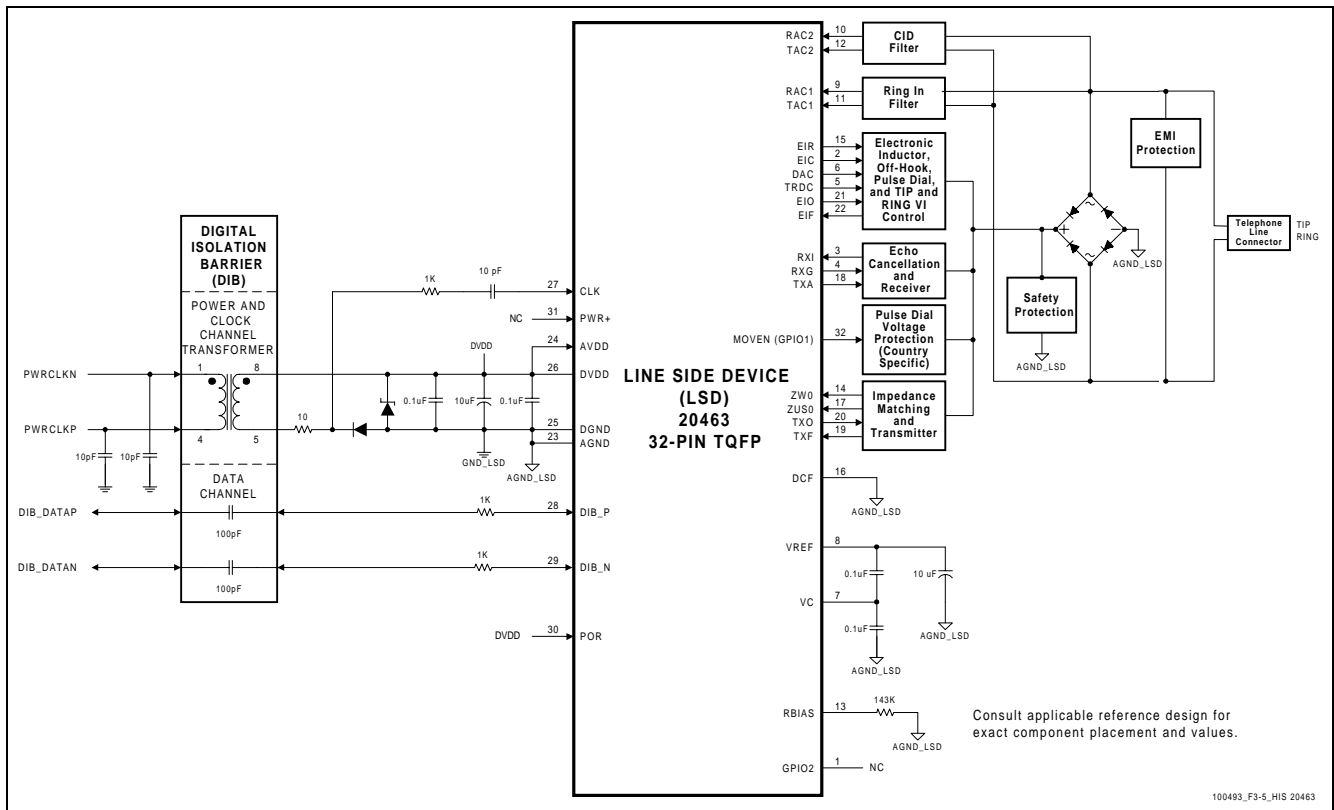

Figure 7. LSD (20463) 32-Pin TQFP Hardware Interface Signals

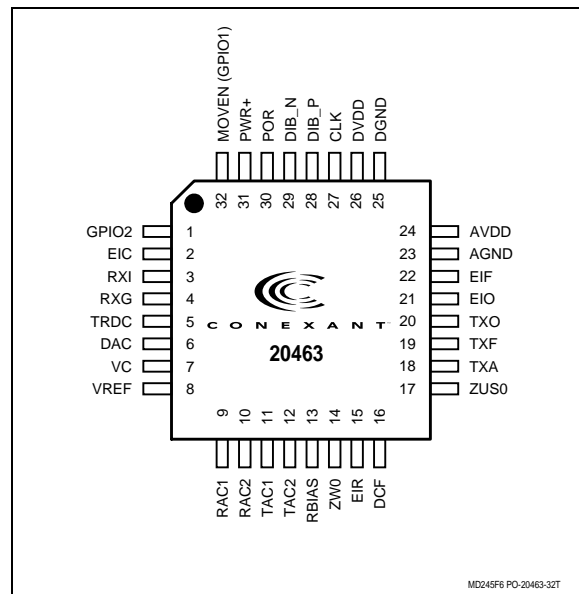

Figure 8. LSD (20463) 32-Pin TQFP Pin Signals

VC (20437) Hardware Pins and Signals (S Model)

General

Microphone and analog speaker interface signals are provided to support functions such as speakerphone mode, telephone emulation, microphone voice record, speaker voice playback, and call progress monitor.

Speakerphone Interface

The following signals are supported:

- Speaker Out (M_SPKR_OUT); analog output
- Microphone (M_MIC_IN); analog input

Telephone Handset/Headset Interface

The following interface signals are supported:

- Telephone Input (M_LINE_IN); input - Not used; leave open
- Telephone output (M_LINE_OUTP); output - Not used; leave open
- Center Voltage (VC); output reference voltage

MDP Interface

The following interface signals are supported:

- Sleep (SLEEP); input
- Master Clock (M_CLKIN); input
- Serial Clock (M_SCK); output
- Control (M_CNTRLSIN); input
- Serial Frame Sync (M_STROBE); output
- Serial Transmit Data (M_TXSIN); input
- Serial Receive Data (M_RXOUT); output

VC Interface Signals and Pin Assignments

The VC (20437) hardware interface signals are shown by major interface in Figure 9 and are shown by pin number in Figure 10.

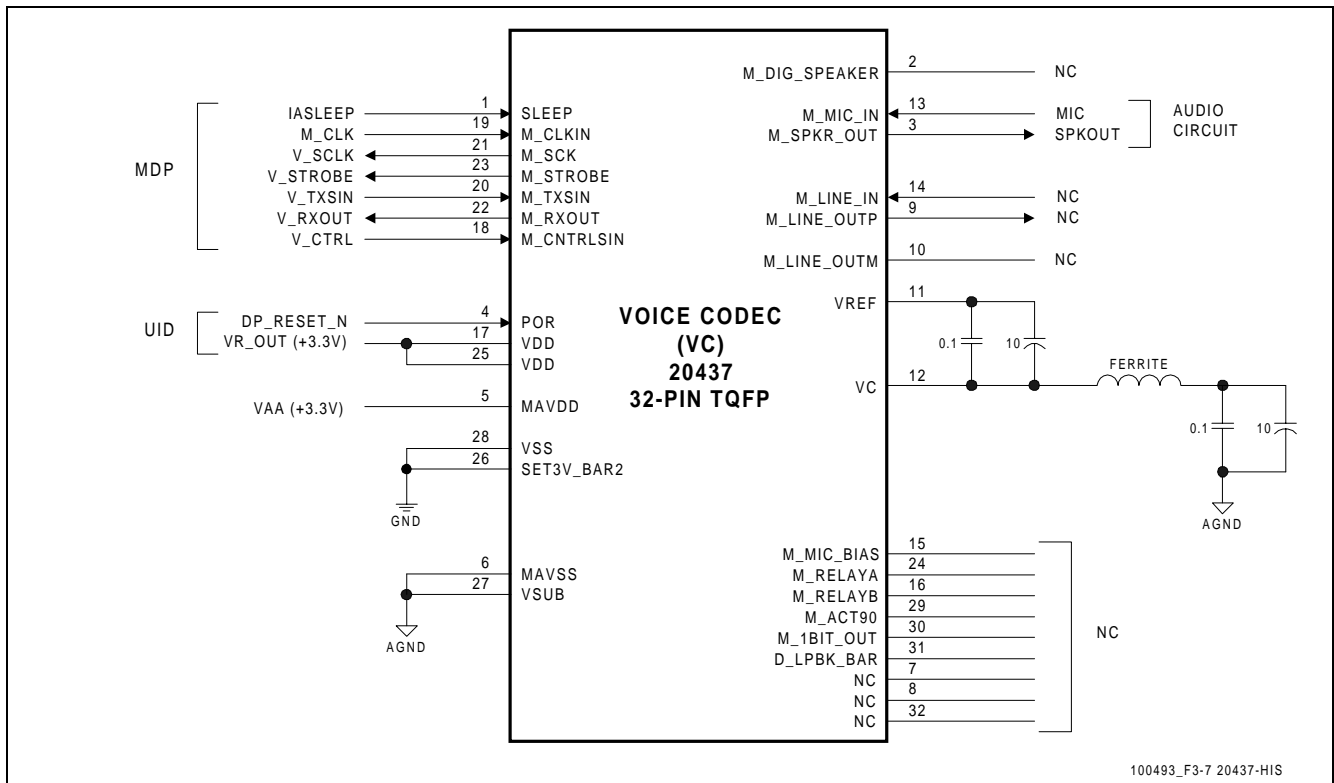

Figure 9. VC (20437) 32-Pin TQFP Hardware Interface Signals

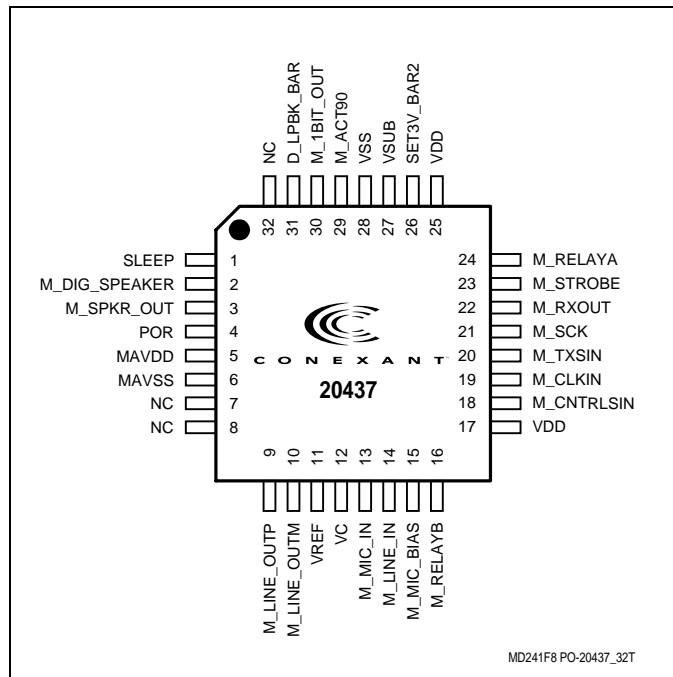

Figure 10. VC (20437) 32-Pin TQFP Pin Signals

Electrical and Environmental Specifications

The operating conditions are specified in Table 2.

The absolute maximum ratings are listed in Table 3.

The current and power requirements are listed in Table 4.

Table 2. Operating Conditions

Parameter	Symbol	Limits	Units
Supply Voltage	V_{DD}	+5.0	VDC
Operating Temperature Range	T_A	0 to +70	°C

Table 3. Absolute Maximum Ratings

Parameter	Symbol	Limits	Units
Supply Voltage	V_{DD}	UID: +4.75 to +5.25 MDP and VC: +3.0 to +3.6	V
Input Voltage	V_{IN}	-0.5 to (VDD + 0.5)	V
Operating Temperature Range	T_A	-0 to +70	°C
Storage Temperature Range	T_{STG}	-55 to +125	°C
Analog Inputs	V_{IN}	-0.3 to (VAA + 0.5)	V
Voltage Applied to Outputs in High Impedance (Off) State	V_{HZ}	-0.5 to (VDD + 0.5)	V
DC Input Clamp Current	I_{IK}	±20	mA
DC Output Clamp Current	I_{OK}	±20	mA
Static Discharge Voltage (25°C)	V_{ESD}	±2500	V
Latch-up Current (25°C)	I_{TRIG}	±400	mA

Table 4. Current and Power Requirements

UIB Bus State	Conditions		Current		Power	
	UIB Powered	MDP Powered	Typical Current	Maximum Current	Typical Power	Maximum Power
Suspend	Yes	No	780 μ A	820 μ A	3.9 μ W	4.3 μ W
Enumeration	Yes	No	22 mA	23 mA	110 mW	120 mW
Operating (Idle)	Yes	Yes	90 mA	95 mA	450 mW	500 mW
Operating (Connected)	Yes	Yes	155 mA	163 mA	775 mW	855 mW

Notes:

Operating voltage: UID VDD = +5.0 V \pm 0.25 V.

Test conditions: UID VDD = +5.0 V for typical values; VDD = + 5.25 V for maximum values.

Test configuration: UID, MDP, LSD, and VC.

Current and power is shown for UID VDD. The MDP and VC +3.3 V power is supplied by the UID VR_OUT. The LSD PWR+ power is supplied by the MDP through the DIB.

Package Dimensions

The package dimensions are shown in Figure 11 (100-pin TQFP), Figure 12 (64-pin TQFP), and Figure 13 (32-pin TQFP).

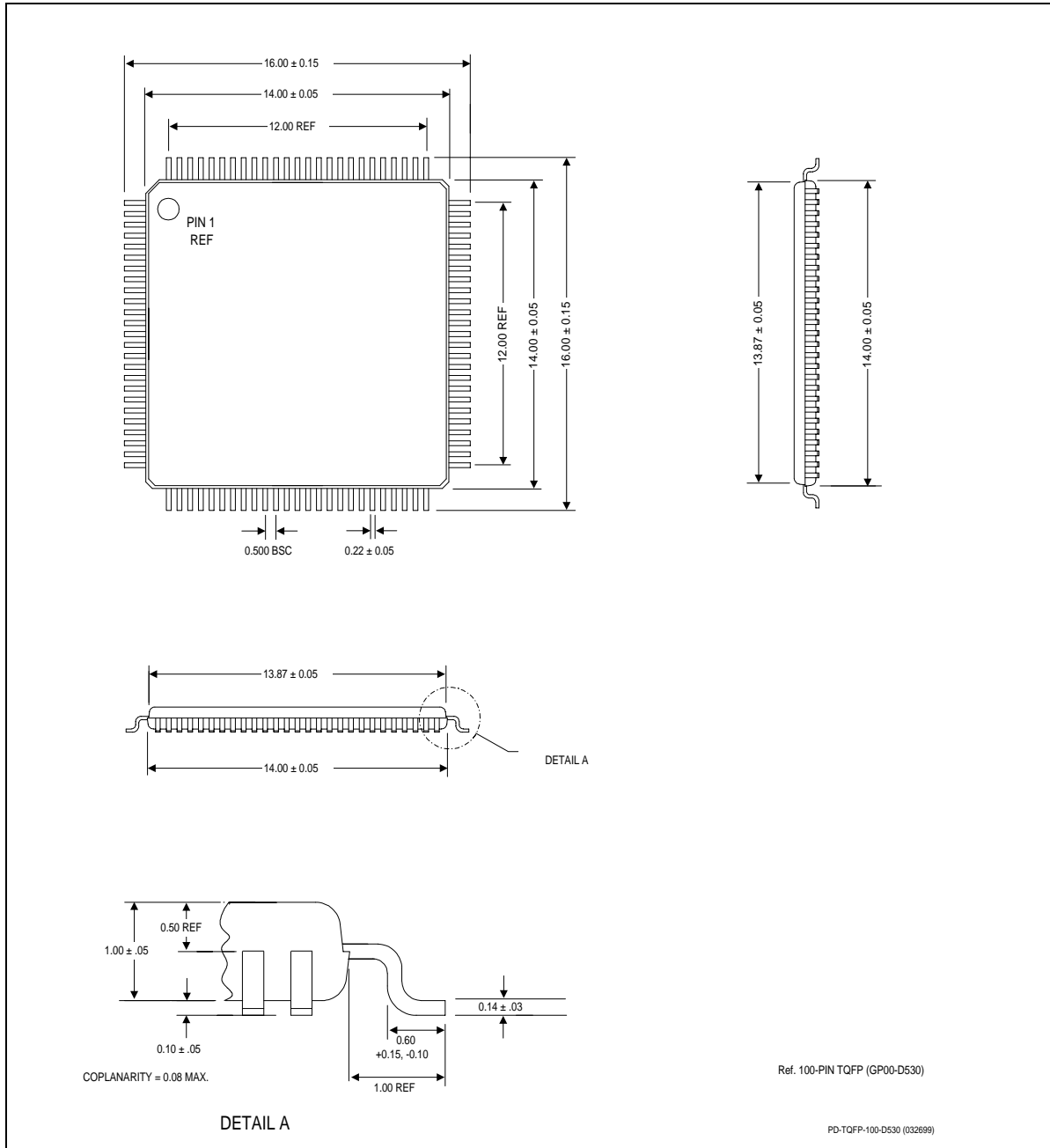
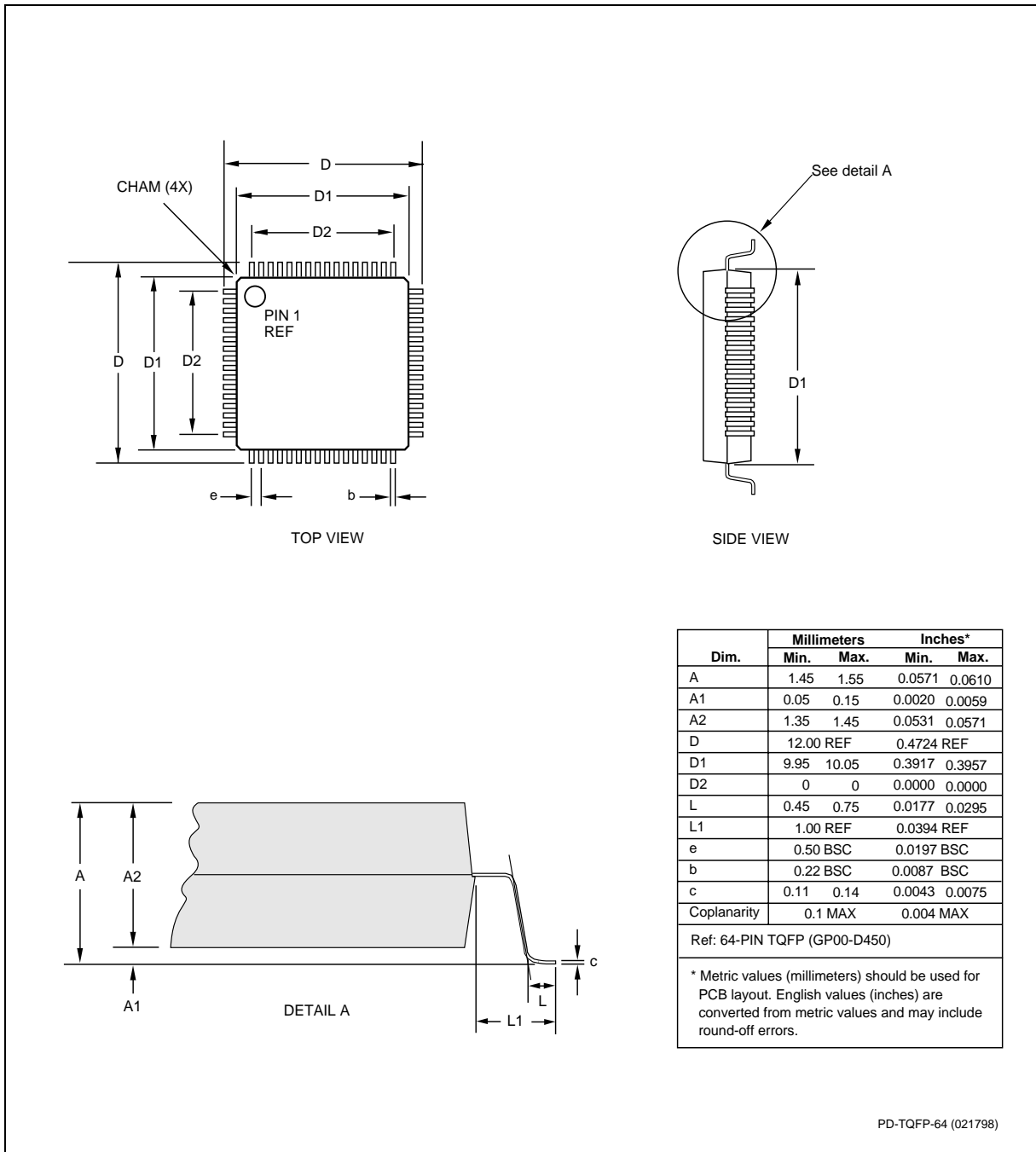

Figure 11. Package Dimensions - 100-Pin TQFP



PD-TQFP-64 (021798)

Figure 12. Package Dimensions - 64-Pin TQFP

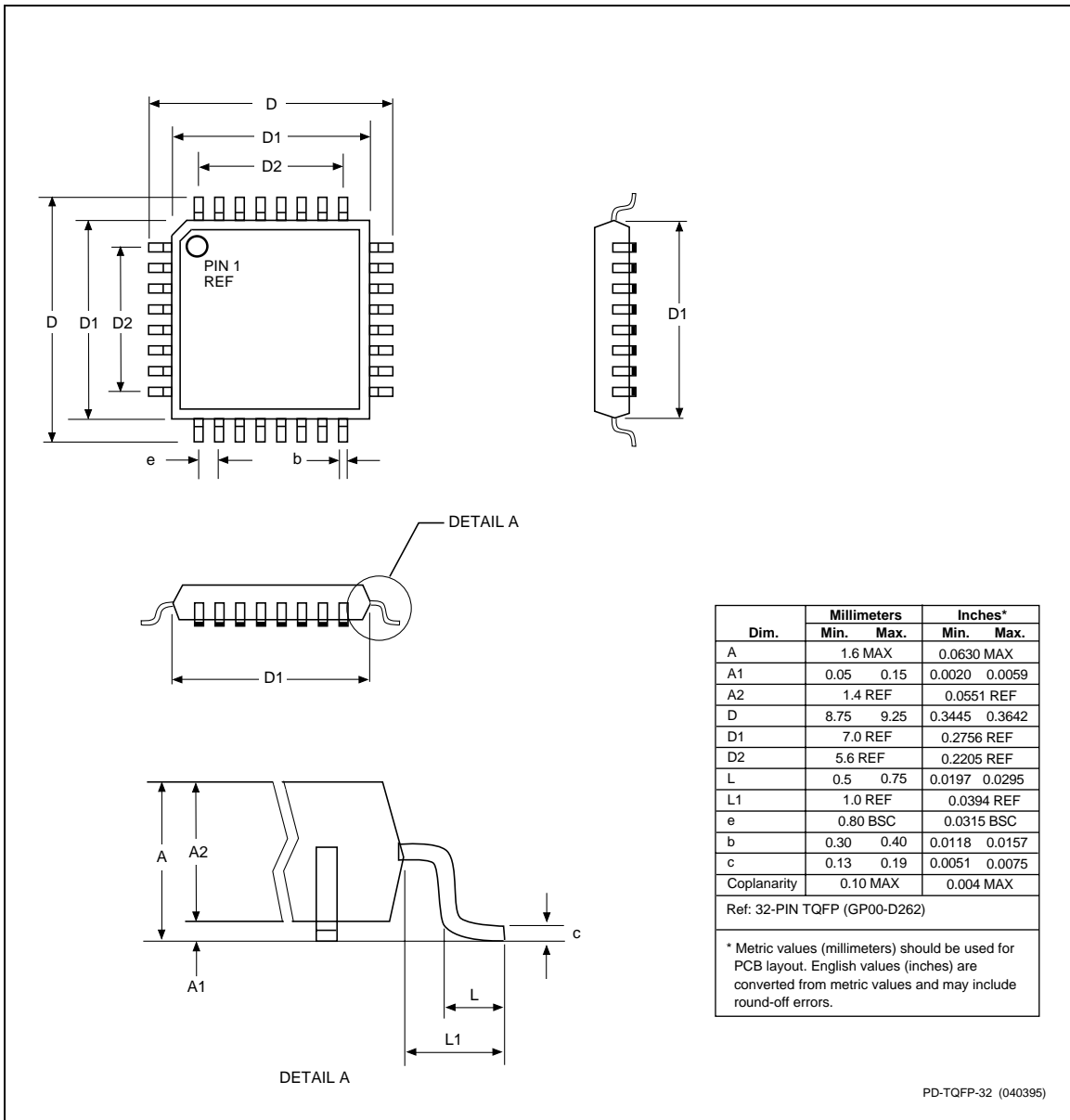

Figure 13. Package Dimensions - 32-Pin TQFP

**Further Information**

literature@conexant.com
1-800-854-8099 (North America)
33-14-906-3980 (International)

Web Site

www.conexant.com

World Headquarters

Conexant Systems, Inc.
4311 Jamboree Road
P. O. Box C
Newport Beach, CA
92658-8902
Phone: (949) 483-4600
Fax: (949) 483-6375

U.S. Florida/South America

Phone: (727) 799-8406
Fax: (727) 799-8306

U.S. Los Angeles

Phone: (805) 376-0559
Fax: (805) 376-8180

U.S. Mid-Atlantic

Phone: (215) 244-6784
Fax: (215) 244-9292

U.S. North Central

Phone: (630) 773-3454
Fax: (630) 773-3907

U.S. Northeast

Phone: (978) 692-7660
Fax: (978) 692-8185

U.S. Northwest/Pacific West

Phone: (408) 249-9696
Fax: (408) 249-7113

U.S. South Central

Phone: (972) 733-0723
Fax: (972) 407-0639

U.S. Southeast

Phone: (919) 858-9110
Fax: (919) 858-8669

U.S. Southwest

Phone: (949) 483-9119
Fax: (949) 483-9090

APAC Headquarters

Conexant Systems Singapore,
Pte. Ltd.
1 Kim Seng Promenade
Great World City
#09-01 East Tower
SINGAPORE 237994
Phone: (65) 737 7355
Fax: (65) 737 9077

Australia

Phone: (61 2) 9869 4088
Fax: (61 2) 9869 4077

China

Phone: (86 2) 6361 2515
Fax: (86 2) 6361 2516

Hong Kong

Phone: (852) 2827 0181
Fax: (852) 2827 6488

India

Phone: (91 11) 692 4780
Fax: (91 11) 692 4712

Korea

Phone: (82 2) 565 2880
Fax: (82 2) 565 1440

Phone: (82 53) 745 2880

Fax: (82 53) 745 1440

Europe Headquarters

Conexant Systems France
Les Taissounieres B1
1681 Route des Dolines
BP 283
06905 Sophia Antipolis Cedex
FRANCE
Phone: (33 1) 41 44 36 50
Fax: (33 4) 93 00 33 03

Europe Central

Phone: (49 89) 829 1320
Fax: (49 89) 834 2734

Europe Mediterranean

Phone: (39 02) 9317 9911
Fax: (39 02) 9317 9913

Europe North

Phone: (44 1344) 486 444
Fax: (44 1344) 486 555

Europe South

Phone: (33 1) 41 44 36 50
Fax: (33 1) 41 44 36 90

Middle East Headquarters

Conexant Systems
Commercial (Israel) Ltd.
P. O. Box 12660
Herzlia 46733, ISRAEL
Phone: (972 9) 952 4064
Fax: (972 9) 951 3924

Japan Headquarters

Conexant Systems Japan Co., Ltd.
Shimomoto Building
1-46-3 Hatsudai,
Shibuya-ku, Tokyo
151-0061 JAPAN
Phone: (81 3) 5371-1567
Fax: (81 3) 5371-1501

Taiwan Headquarters

Conexant Systems, Taiwan Co.,
Ltd.
Room 2808
International Trade Building
333 Keelung Road, Section 1
Taipei 110, TAIWAN, ROC
Phone: (886 2) 2720 0282
Fax: (886 2) 2757 6760