

DSP-8661

16-ch PCIe Versatile Video Processing Board with SDK



Features

- Powered by TI TMS320DM8168 SoC
- 16-ch composite video and audio inputs
- H.264 / MJPEG / RAW H/W encoding up to 480fps at D1
- H.264 / MJPEG / RAW H/W decoding up to 480fps at D1
- One HDMI supports AV display up to 1080p at 60fps
- Embedded with 1.0GHz C674X VLIW DSP
- Versatile peripherals: GbE LAN port, SATA, USB 2.0, I²C and UART
- Half-size form factor and fanless H/W design
- Windows / Linux PC driver and SDK with sample codes



Introduction

Designed with TMS320DM8168 SoC, DSP-8661 is a full-functional video processing platform with 16-ch composite video and audio inputs based on a standard half-length PCIe board form factor. The board supports H.264 / MJPEG / RAW encode / decode up to D1 resolution at a real-time frame rate (30/25fps) for all channels simultaneously. HDMI provides up to 1080p 60fps video / audio outputs that fulfills high-definition display requirements. Equipped with a high-performance C674X Digital Signal Processor (DSP), DSP-8661 can manage a system's host processing by executing image enhancement and video analytics programs. The I²C and UART interfaces are designed for extending the control and indicator functions like RS-485 and DIO (on the optional DIO & Control Board). With an easy-to-use software development kit (SDK), the DSP-8661 is an ideal solution for system integrators working to implement diverse video-processing related applications that fit a broad spectrum of customer requirements.

Specifications

Video Input	Channels	16
	Input Format	Composite for NTSC/PAL
	Resolution	Up to D1 (720 x 576)
	Compression	H.264/MJPEG/RAW
	Max. Frame Rate	480/400 fps (NTSC/PAL) at D1
	Bit Rate Control	CBR & VBR
	Connectors	DVI x1 (for connecting 16 x BNC + 8 x RCA to DVI octopus cable), Pin header x1 (Alternative for 16-ch video inputs)
Audio Input	Channels	8 + 8 (optional)
	Format	RAW
	Sampling Rate	Up to 16-bit, 44KHz
	Connectors	DVI x1 (8-ch audio shared with video-input connector) Pin header x1 (for connecting the optional Audio & Loop-out Board; supports the other 8ch audio-in)
Video Output	RCA	1
	Loop-out	16-ch pin header on board (connecting the optional Audio & Loop-out Board)
	HDMI out	1, resolution up to 1080P, frame rate up to 60fps
Peripherals	GbE Lan Port	RJ-45 x1
	USB 2.0 Port	A-type Female x1
	SATA Port	x1 (3.0 Gbps)
	I ² C and UART	Pin-header x1 for connecting the optional DIO and Control Board
	Data Bus	PCI Express 2.0, Gen2, x1
Accessories	Cable	16xBNC + 8xRCA to DVI Octopus Cable
	Expansion Board (optional)	JTAG Debug Board (with 1x Board-to-board flat cable) Audio & Loop-out Board: Audio-out + 8ch Audio-in + 16ch Video Loop-out (with 1x Octopus Cable + 1x Board-to-board flat cable) DIO & Control Board: 16x DI + 8x DO (Relay) + 1x RS-485 (with 1x Board-to-board flat cable)
	Physical Characteristics	Power Consumption < 26W Operating Temperature -20 ~ 70° C / -4 ~ 158° F (with air flow) Dimensions 140 x 111.15 mm (5.51" x 4.38")
Software	OS Supported by Driver	Linux; Windows XP / XPe / Vista / 7
	SDK	User's Manual, Programming Guide, Sample Codes
	Demo Program	16-ch Video Capturing and H.264 Encoding at PCIe Device Mode
Applications	PCIe Device Mode	PCIe digital video capturing & encoding card PCIe video decoder card with HDMI out PCIe DSP-based intelligent video analytics card

Block Diagram

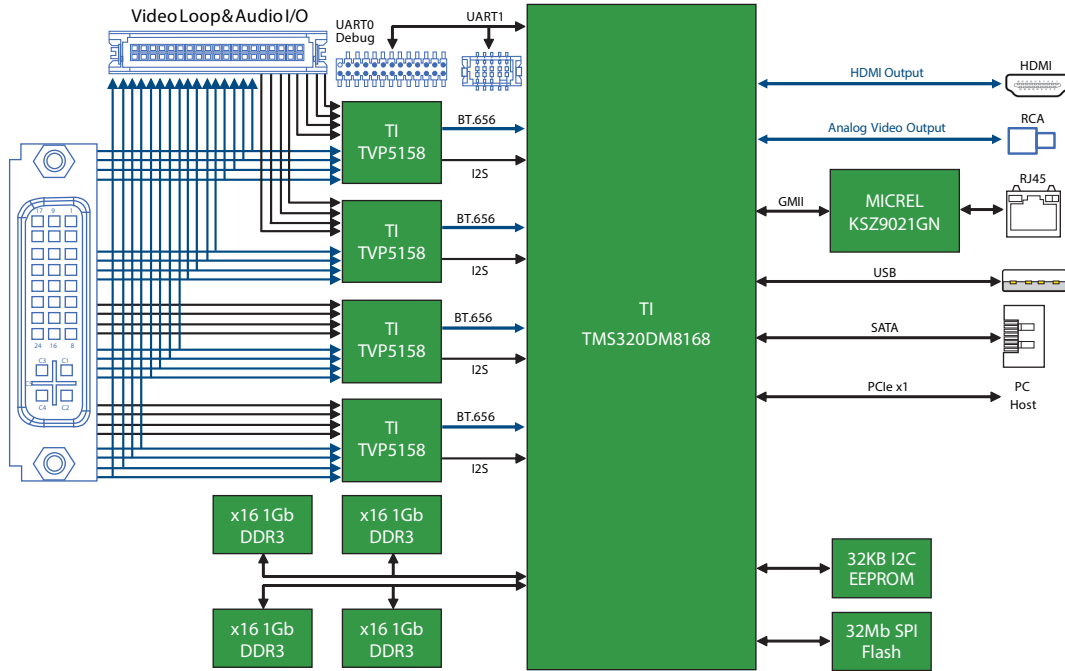

Dimensions

Unit: mm

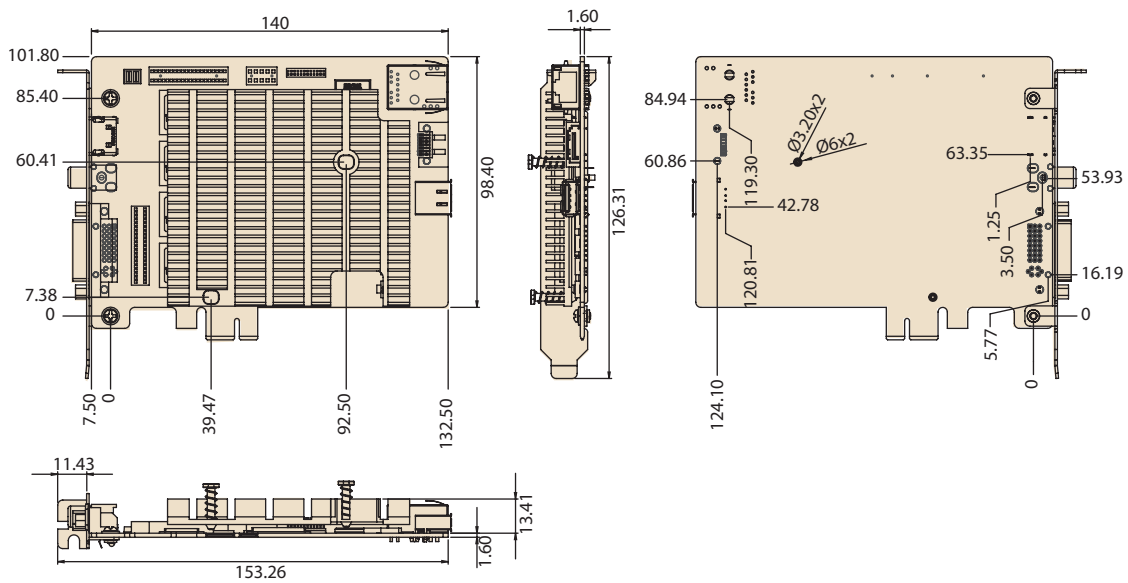

Ordering Information

Part Number	Description
DSPC-8661-PCXE	16-ch PCIe Versatile Video Processing Board with SDK
DSPC-8661ACY01-AE	JTAG Debug Board with cable
DSPC-8661ACY02-AE	Audio-in & Loop-out Board for DSP-8661-PCXE with cables
DSPC-8661ACY03-AE	DIO & Control Board for DSP-8661-PCXE with cable