

APK3020NC PURE ORANGE

### Features

- 3.0mmX2.0mm SMTLED, 1.3mm THICKNESS.
- LOW POWER CONSUMPTION.
- WIDE VIEWING ANGLE.
- IDEAL FOR BACKLIGHT AND INDICATOR.
- VARIOUS COLORS AND LENS TYPES AVAILABLE.
- PACKAGE:2000PCS/REEL

### Description

The Pure Orange source color devices are made with Gallium Arsenide Phosphide on Gallium Phosphide Pure Orange Light Emitting Diode.

### Package Dimensions

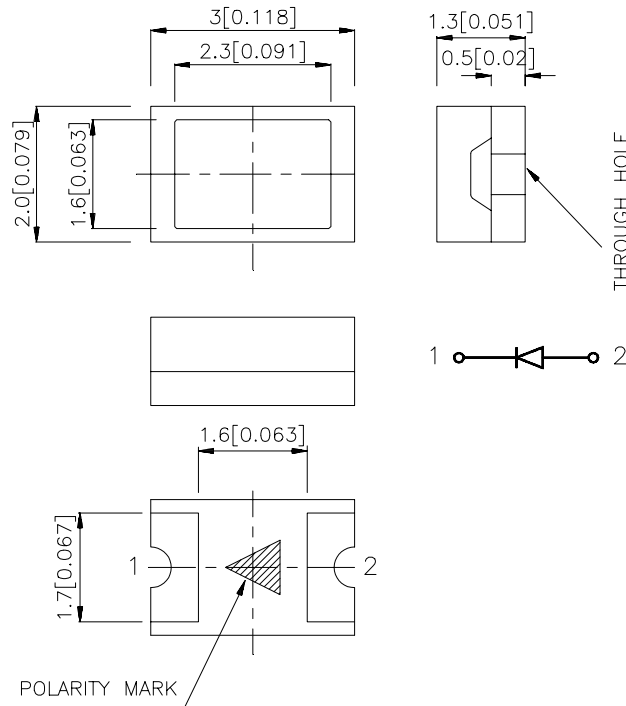

#### Notes:

1. All dimensions are in millimeters (inches).
2. Tolerance is  $\pm 0.2$  (0.0079") unless otherwise noted.
3. Lead spacing is measured where the lead emerge package.
4. Specifications are subject to change without notice.

## Selection Guide

Part No.	Dice	Lens Type	Iv (mcd) @ 20 mA		Viewing Angle
			Min.	Typ.	2θ1/2
APK3020NC	PURE ORANGE (GaAsP/GaP)	WATER CLEAR	8	30	120°

Note:

1. θ1/2 is the angle from optical centerline where the luminous intensity is 1/2 the optical centerline value.

## Electrical / Optical Characteristics at T<sub>A</sub>=25°C

Symbol	Parameter	Device	Typ.	Max.	Units	Test Conditions
λ <sub>peak</sub>	Peak Wavelength	Pure Orange	607		nm	IF=20mA
λ <sub>D</sub>	Dominate Wavelength	Pure Orange	610		nm	IF=20mA
Δλ <sub>1/2</sub>	Spectral Line Halfwidth	Pure Orange	35		nm	IF=20mA
C	Capacitance	Pure Orange	15		pF	VF=0V;f=1MHz
V <sub>F</sub>	Forward Voltage	Pure Orange	2.05	2.5	V	IF=20mA
I <sub>r</sub>	Reverse Current	Pure Orange		10	μA	VR = 5V

## Absolute Maximum Ratings at T<sub>A</sub>=25°C

Parameter	Pure Orange	Units
Power dissipation	105	mW
DC Forward Current	30	mA
Peak Forward Current [1]	145	mA
Reverse Voltage	5	V
Operating/Storage Temperature	-40°C To +85°C	

Note:

1. 1/10 Duty Cycle, 0.1ms Pulse Width.

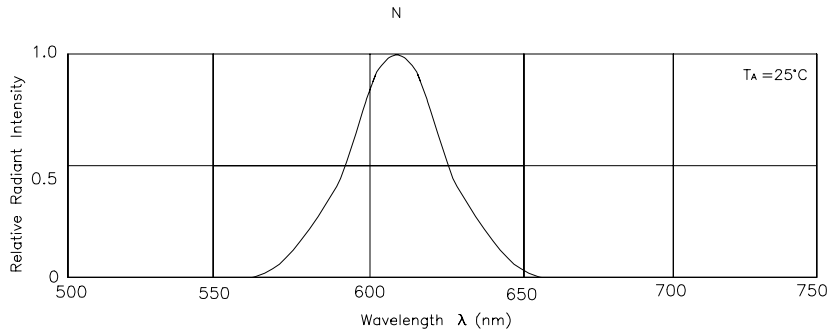

RELATIVE INTENSITY Vs. WAVELENGTH

## Pure Orange APK3020NC

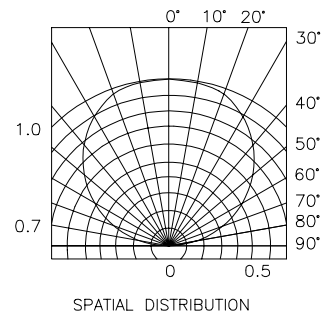
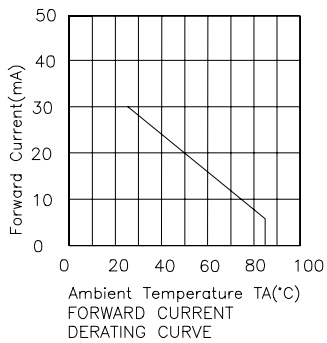
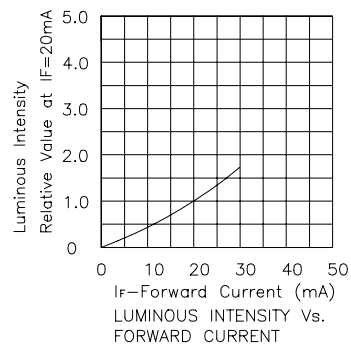
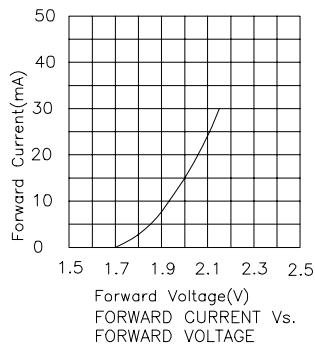

## APK3020NC SMT Reflow Soldering Instructions

Number of reflow process shall be less than 2 times and cooling process to normal temperature is required between first and second soldering process.

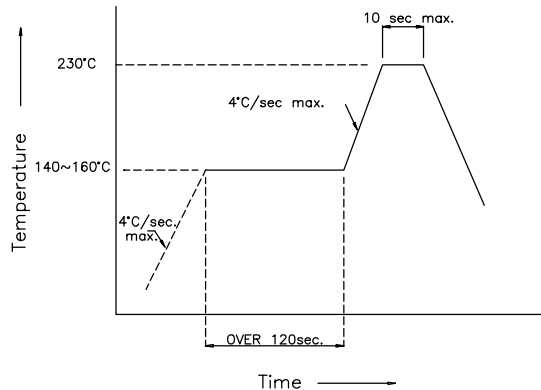

## Recommended Soldering Pattern (Units : mm)

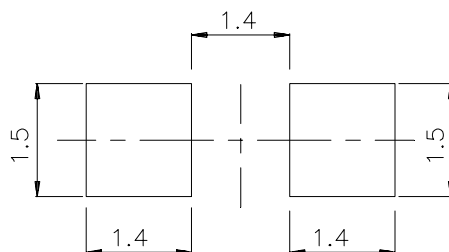

## Tape Specifications (Units : mm)

