

300mA Bi-Direction Relay Driver

DESCRIPTION

BL8023F is a bi-direction relay driver circuit, used to control the magnetic latching relay, with large output capability, ultra-low power consumption. It can be widely used in smart meters and other pulses, level control applications.

BL8023F can provide 300mA typical driving current, which will differ according to the relay coil resistance. The input High Level Threshold of BL8023F is 2V; it can compatible with most single chip microcontroller.

BL8023F is available in SOT-23-6 packages.

FEATURES

- 5 to 36V input voltage range
- Low Power Consumption ($I_Q < 1\mu A$)
- Input High Level Threshold: 2V, compatible with most single chip microcontroller
- Typical Driving Current: 300mA
 $R_{ds(on)} = 12\Omega$ ($V_{in} = 12V$, PMOSFET+NMOSFET)
 $R_{ds(on)} = 10\Omega$ ($V_{in} = 30V$, PMOSFET+NMOSFET)
- Peak Driving Current: 500mA@ $V_{in} = 24V$
- Environment Temperature: $-40^\circ C \sim 85^\circ C$
- SOT-23-6 packages

APPLICATIONS

- Smart Meter

TYPICAL APPLICATION

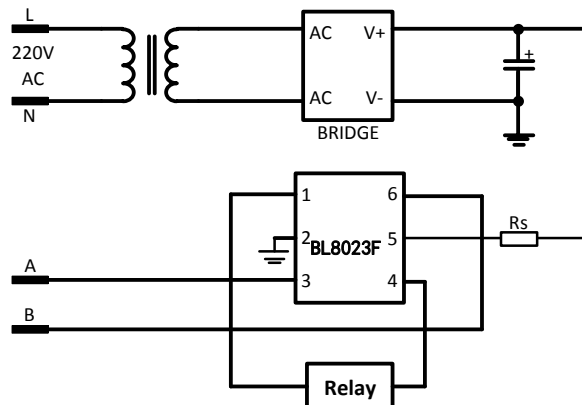

ORDERING INFORMATION

Part No.	Package	Tape & Reel
BL8023FCB6TR	SOT-23-6	3000/Reel

PIN OUT & MARKING

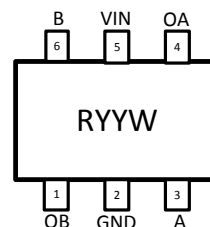

SOT23-6

RY: Product Code
 YW: Date code

ABSOLUTE MAXIMUM RATING

Parameter		Value	
Max Input Voltage		40V	
Max Operating Junction Temperature(Tj)		150°C	
Ambient Temperature(Ta)		-40°C – 125°C	
Package Thermal Resistance	SOT23-6	θ_{ja}	190°C / W
		θ_{jc}	110°C / W
Storage Temperature(Ts)		-40°C - 150°C	
Lead Temperature & Time		260°C, 10S	

Note: Exceed these limits to damage to the device. Exposure to absolute maximum rating conditions may affect device reliability.

RECOMMENDED WORK CONDITIONS

Parameter	Value
Input Voltage Range	Max.36V
Operating Junction Temperature(Tj)	-40°C – 85°C

ELECTRICAL CHARACTERISTICS

(VIN=5V, TA=25°C)

Symbol	Parameter	Conditions	Min	Typ	Max	Unit
VIN	Input Voltage Range		5		36	V
Iq	Quiescent Current				1	uA
Rdson	Switch Rdson	Vin=12V, RL=75ohm		12	18	ohm
		Vin=30V, RL=75ohm		10	16	ohm
		Vin=12V, RL=40ohm		12	20	ohm
		Vin=30V, RL=40ohm		10	16	ohm
VTH	ON Input High Voltage	Vin=12V		2		V
RIN	Equivalent Input Resistor			500		Kohm
VSD	Fly-Wheel Diode Forward Voltage	Is=1A		0.8	1.5	V
TR	Rise Time	VIN=12V, RL=75ohm		40		ns
TD(ON)	Turn ON Delay Time	VIN=12V, RL=75ohm		60		ns
TF	Fall Time	VIN=12V, RL=75ohm		30		ns
TD(OFF)	Turn OFF Delay Time	VIN=12V, RL=75ohm		70		ns

Note: 1) This condition is not suitable for SOT23-6 package.

2) Input rise/fall time must less than 1ms, otherwise maybe destroy the chip.

LOGIC FUNCTION TABLE

Input A	Input B	Output OA	Output OB	RELAY RESPONSE
1	0	1	0	ON
0	1	0	1	OFF
0	0	High-impedance	High-impedance	Hold
1	1	High-impedance	High-impedance	Hold

PIN DESCRIPTION

PIN #	NAME	DESCRIPTION
1	OB	Output B
2	GND	Ground.
3	A	Input A
4	OA	Output A
5	VIN	Supply input voltage
6	B	Input B

ELECTRICAL PERFORMANCE

Tested under $T_A=25^{\circ}\text{C}$, unless otherwise specified

Turn on delay and rise time

Ch1---Input Ch2---Output

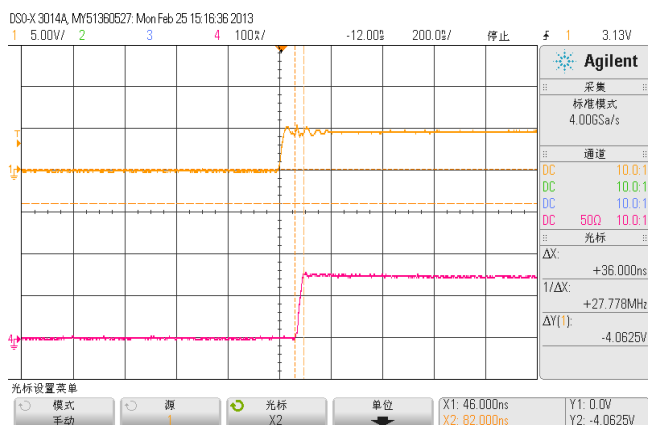

Turn off delay and fall time

Ch1---Input Ch2---Output



Forward Voltage

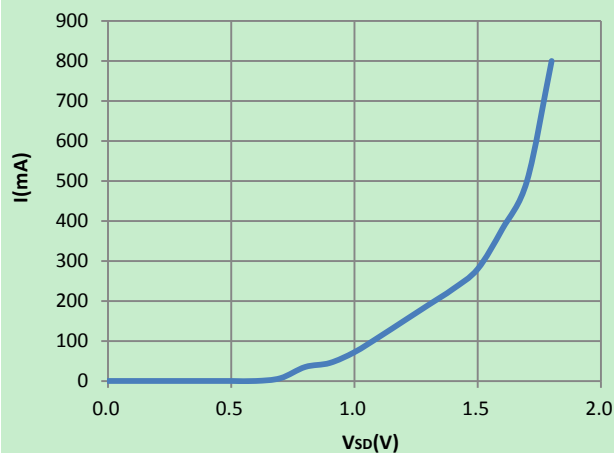

Vth VS. Vin

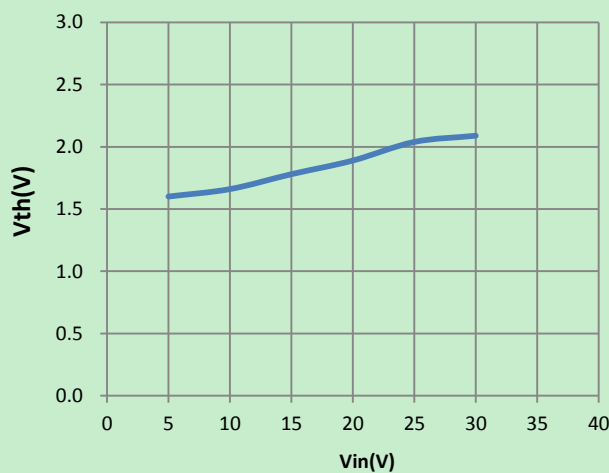

BLOCK DIAGRAM

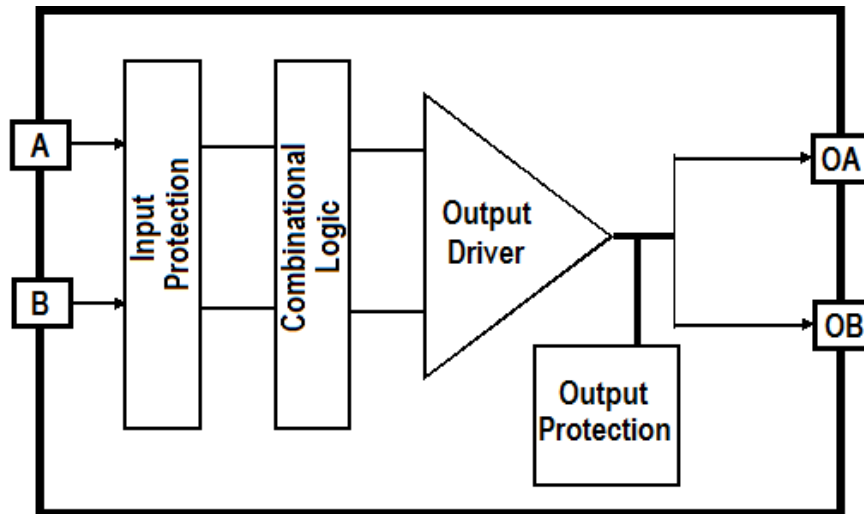

DETAILED DESCRIPTION

Pulse Triggering

If input is driven by square pulse, connect the inputs to the pulse source directly. Relay will operate as logic table stated (V_{in} should be less than the power supply voltage, R_s is current-limiting resistor, it can be ignored in the voltage is below 20V, i.e. $R_s=0$).

The recommended pulse width=100ms. The length of the intervals should be longer than 100ms. These intervals include: intervals between forward drive pulse and next backward drive pulse, intervals between forward drive pulse and next forward drive pulse, intervals between backward drive pulse and next forward drive pulse, intervals between backward drive pulse and next backward drive pulse.

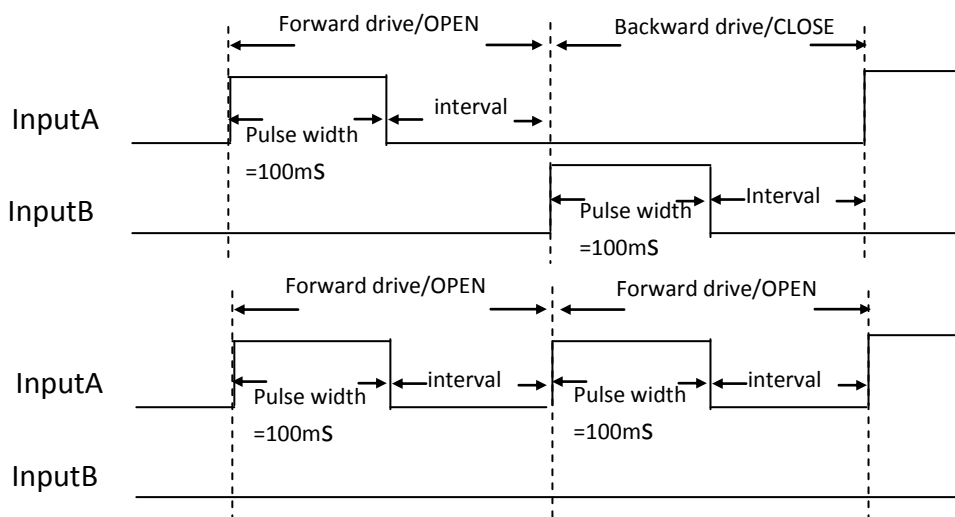

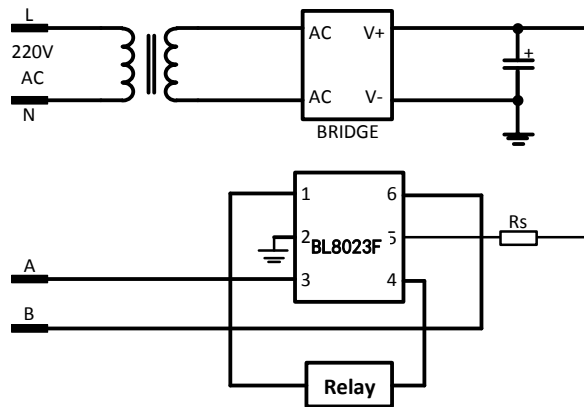

Pulse triggering application diagram

Level Triggering

If input is driven by voltage level, resistor R1, R2 should be used to insure low voltage standby input. Apply input voltage according to logic table drives the relay correspondingly (R1, R2=30K-100K, R3, R4=100K, C1, C2=10n, recommended for removing input spikes; V_{in} should be less than the power supply voltage, R_s is current-limiting resistor, it can be ignored in the voltage is below 20V, i.e. $R_s=0$).

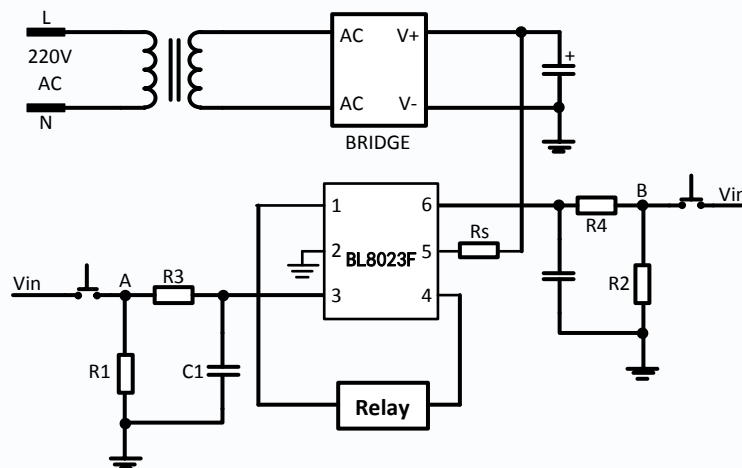

Level triggering application diagram

Relay free-wheel

Relay from ON to OFF, the energy stored in the relay inductor released by the chip's internal body diode and the relay inductor. Until the end of the release of this energy, relay proceeding to the next operation.

PACKAGE OUTLINE

Package	SOT23-6	Devices per reel	3000	Unit	mm
Package specification:					
<p>The technical drawing illustrates the SOT23-6 package with the following dimensions:</p> <ul style="list-style-type: none"> Top View: <ul style="list-style-type: none"> Total width: 2.9 ± 0.2 mm Distance between pins 4 and 5: 1.9 ± 0.2 mm Pin pitch (between pins 4, 5, and 6): 0.95 mm Pin 1 to 2 distance: $0.4^{+0.1}_{-0.2}$ mm Side View: <ul style="list-style-type: none"> Maximum height: 2.8 ± 0.3 mm Height to top of pins: $1.6^{+0.2}_{-0.1}$ mm Lead length: $1.1^{+0.2}_{-0.1}$ mm Lead thickness: 0.8 ± 0.1 mm Lead width at base: $0.15^{+0.1}_{-0.05}$ mm Minimum lead thickness: 0.2 MIN mm Lead angle: 0 to 0.1 degrees 					