

+12V, 30mA Flash Memory Programming Supply

DESCRIPTION

The BL8052 is a regulated +12V, 30mA-output, chargepump DC-DC converter. It provides the necessary +12V $\pm 5\%$ output to program byte-wide flash memories, and requires no inductors to deliver a guaranteed 30mA output from inputs as low as 4.75V. It fits into less than 0.1in² of board space. The BL8052 is a pin-compatible upgrade to the BL8051, and is recommended for new designs. The BL8052 offers lower quiescent and shutdown currents, and guarantees the output current over all temperature ranges.

The BL8052 is the first charge-pump boost converter to provide a regulated +12V output. It requires only a few inexpensive capacitors, and the entire circuit is completely surface-mountable. A logic-controlled shutdown pin that interfaces directly with microprocessors reduces the supply current to only 0.3 μ A. The BL8052 comes in 8-pin narrow SO and DIP packages.

FEATURES

- Regulated +12V $\pm 5\%$ Output Voltage
- 4.5V to 5.5V Supply Voltage Range
- Fits in 0.1in²
- Guaranteed 30mA Output
- No Inductor—Uses Only 4 Capacitors
- 95 μ A Quiescent Current
- Logic-Controlled 0.3 μ A Shutdown
- 8-Pin Narrow SO and DIP Packages

APPLICATIONS

- +12V Flash Memory Programming Supplies
- Compact +12V Op-Amp Supplies
- Switching MOSFETs in Low-Voltage Systems
- Dual-Output +12V and +20V Supplies

TYPICAL APPLICATION

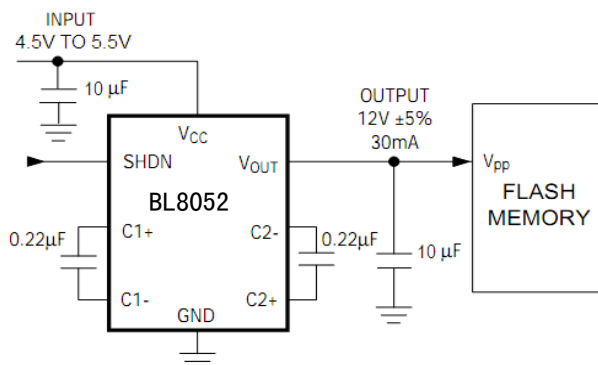

PIN OUT & MARKING

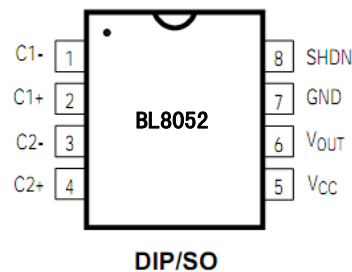

ABSOLUTE MAXIMUM RATING

Parameter	Value
Max Input Voltage	6V
SHDN	0.3V~(Vin+0.3V)
Iout Continuous	50mA
Max Operating Junction Temperature(TJ)	125°C
Ambient Temperature(TA)	-40°C – 85°C
Thermal resistance: Θ_{JA}	150°C/W
Storage Temperature(TS)	-40°C - 150°C
Lead Temperature & Time	260°C, 10S

Note: Exceed these limits to damage to the device. Exposure to absolute maximum rating conditions may affect device reliability.

RECOMMENDED WORK CONDITIONS

Parameter	Value
Input Voltage Range	Max. 6V
Operating Junction Temperature(TJ)	-20°C – 125°C

ELECTRICAL CHARACTERISTICS For Each Channel

(Vcc=4.5V to 5.5V, TA=25°C, unless otherwise noted)

Symbol	Parameter	Conditions	Min	Typ	Max	Unit
Vcc	Breakdown Supply Voltage	No load, V _{SHDN} =0V		9.4		V
Vout	Output Voltage	0mA ≤ Iout ≤ 30mA, Vcc = 4.5V to 5.5V		12		V
		0mA ≤ Iout ≤ 20mA		12		
Icc	Supply Current	No load, V _{SHDN} =0V		95	500	uA
	Shutdown Current	No load, V _{SHDN} =Vcc		0.3	10	uA
f _{osc}	Oscillator Frequency	Vcc=4V, Iout=30mA		620		kHz
	Power Efficiency	Vcc=5V, Iout=30mA		76.4		
R _{sw}	Vcc to Vout Switch Impedance	Vcc=V _{SHDN} =5V	Iout=77uA		2.6	kohm
			Iout=37uA		2.7	
V _{IH}	Shutdown Input Threshold		2.4	2.5		V
V _{IL}					1.3	
	SHDN Pin Current	Vcc=5V, V _{SHDN} =0V		0		uA
		Vcc=V _{SHDN} =5V		0		

PIN DESCRIPTION

PIN #	NAME	DESCRIPTION
1	C1-	Negative terminal for the first chargepump capacitor
2	C1+	Positive terminal for the first chargepump capacitor
3	C2-	Negative terminal for the second charge-pump capacitor
4	C2+	Positive terminal for the second charge-pump capacitor
5	Vcc	Supply Voltage
6	Vout	+12V Output Voltage. VOUT = VCC when in shutdown mode.
7	GND	Ground
8	SHDN	Active-high CMOS-logic level Shutdown Input. SHDN is internally pulled up to VCC. Connect to GND for normal peration. In shutdown mode, the charge pumps are turned off and VOUT = VCC.

BLOCK DIAGRAM

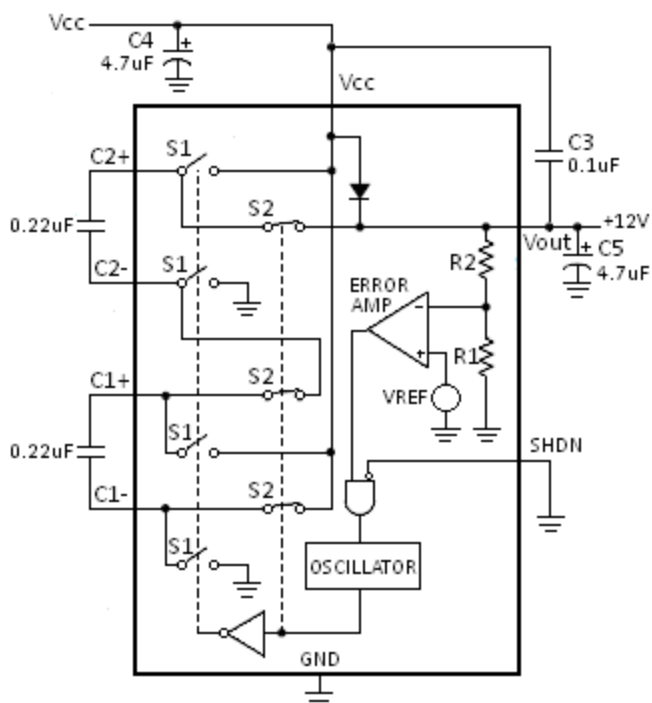

C3 must be placed as close to the device as possible and could be omitted if very low output noise performance are not required.

Figure1 Block Diagram

TYPICAL PERFORMANCE CHARACTERISTICS

(Tested under TA=25°C, unless otherwise specified)

SUPPLY CURRENT vs. SUPPLY VOLTAGE

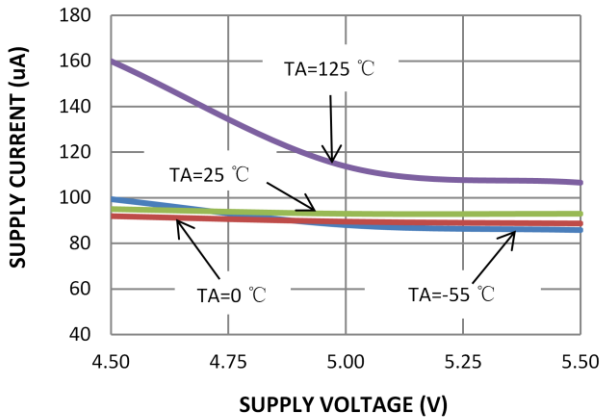

EFFICIENCY vs. LOAD CURRENT

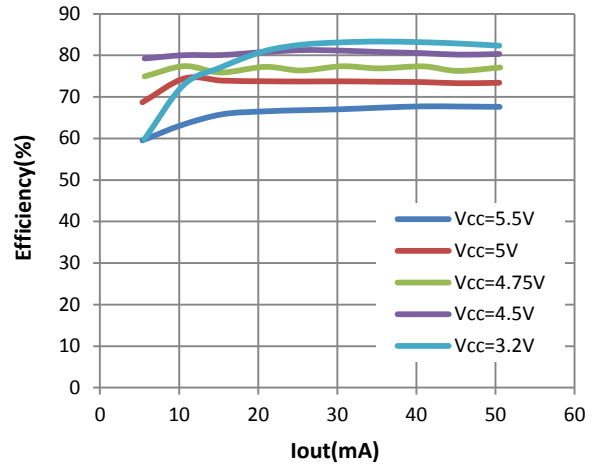

OUTPUT VOLTAGE vs. OUTPUT CURRENT

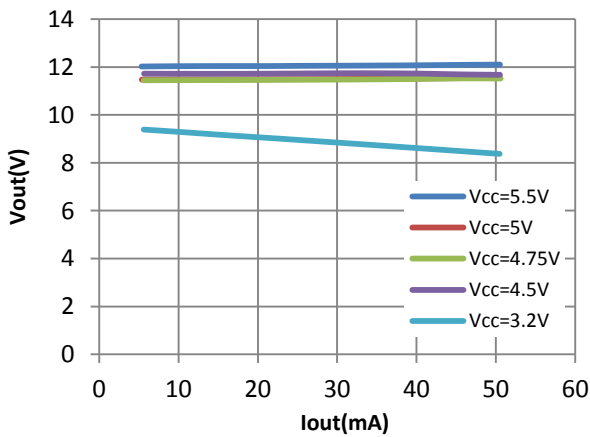

LOAD TRANSIENT RESPONSE

C1: Output Voltage Ripple, Vcc=5.0V
C4: Output Current, Iout=0mA to 30mA

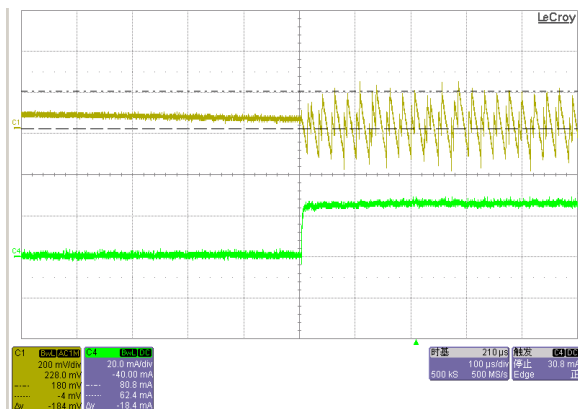

LINE TRANSIENT RESPONSE

C1: Output Voltage Ripple
C3: Supply Voltage, Vcc=4.5V to 5.5V, Iout=10mA

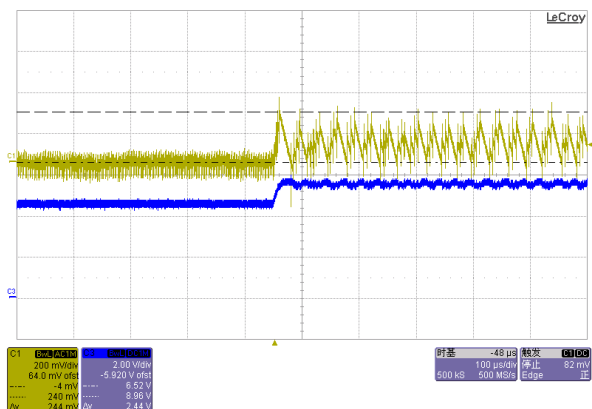

DETAILED DESCRIPTION

BL8052 is a charge-pump IC. It can provide a 12V regulated output 30mA from voltage input as low as 4.75 without any inductors. It is useful for a wide range of applications and its performances makes it ideal for flash memory programming supply.

Figure 1 is a simplified block diagram of BL8052. When the S1 switches are closed and the S2 switches are open, capacitors C1 and C2 are charged up to VCC. And then the S1 switches are opened and the S2 switches are closed, capacitors C1 and C2 are connected in series between VCC and VOUT. A feedback scheme adjusts the output voltage to 12V \pm 5%.

A good layout design is strongly recommended for noise reason. Very short connections to the capacitors should be used for best performance. C3 and C4 must have low ESR in order to minimize the output ripple. C1 and C2 should use ceramic or tantalum capacitors in the 0.22 μ F to 1.0 μ F range.

PACKAGE OUTLINE

