

500 mA very low drop voltage regulator

Datasheet - production data



Features

- Input voltage from 2.5 to 16 V
- Very low dropout voltage (300 mV max. at 500 mA load)
- Low quiescent current (200 μ A typ. @ 500 mA load)
- Available in 1% precision in PPAK and DFN6 packages, 2% in DPAK
- 500 mA guaranteed output current
- Wide range of output voltages available on request: adjustable from 0.8 V, fixed up to 12 V in 100 mV steps
- Logic-controlled electronic shutdown
- Power Good (PPAK and DFN packages)
- Fast dynamic response to line and load changes
- Internal current and thermal protection
- Temperature range: - 40 °C to 125 °C

Applications

- PCs and laptop computers
- Battery-powered equipment
- Industrial and medical equipment
- Portable equipment

Description

The LDFM is a fast, very low drop linear regulator which operates from an input supply voltage in the range of 2.5 V to 16 V.

It is available in fixed and adjustable output voltage versions, from 0.8 V to 12 V.

The LDFM features high output precision, very low dropout voltage, low noise, and low quiescent current, therefore suitable for low voltage microprocessors and memory applications.

Enable logic control pin and Power Good output are featured on PPAK/DFN packages.

Current and thermal protection are provided.

Contents

1	Block diagram	3
2	Pin configuration	4
3	Typical application	5
4	Absolute maximum ratings	6
5	Electrical characteristics	7
6	Application information	11
6.1	External capacitors	11
6.1.1	Input capacitor	11
6.1.2	Output capacitor	11
6.2	Enable pin operation	11
6.3	Power Good	11
7	Typical performance characteristics	12
8	Package mechanical data	16
9	Packaging mechanical data	27
10	Order codes	32
11	Revision history	33

1 Block diagram

Figure 1. Block diagram (generic version)

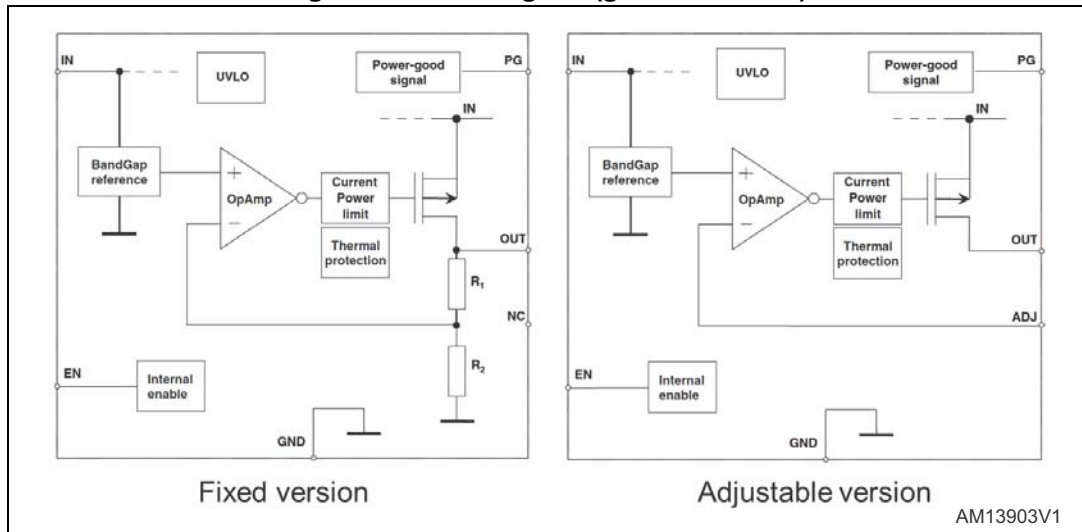

2 Pin configuration

Figure 2. Pin connection (top view)

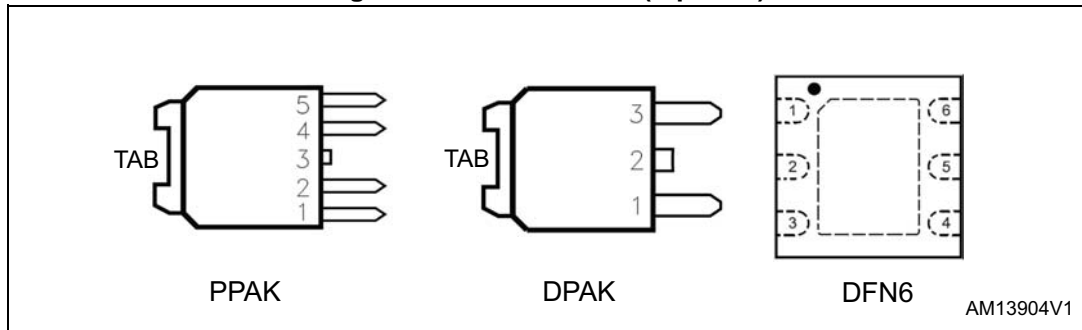

Table 1. Pin description DPAK, PPAK

Pin n°		Symbol	Function
PPAK	DPAK		
5	-	ADJ/PG	For adjustable versions: Error amplifier input pin. For fixed version: Power Good output
2	1	V _{IN}	Input voltage
4	3	V _{OUT}	Output voltage
1	-	EN	Enable pin logic input: Low = shutdown, High = active
3	2	GND	Ground
TAB	TAB	GND	Ground

Table 2. Pin description DFN6-2x2 and 3x3

Pin n°	Symbol	Function
2	ADJ/NC	For adjustable versions: error amplifier input pin. For fixed version: not connected
6	V _{IN}	Input voltage
1	V _{OUT}	Output Voltage
5	EN	Enable pin logic input: low = shutdown, high = active
3	PG	Power good output
4	GND	Ground
exposed pad	GND	Ground

3 Typical application

Figure 3. Fixed versions

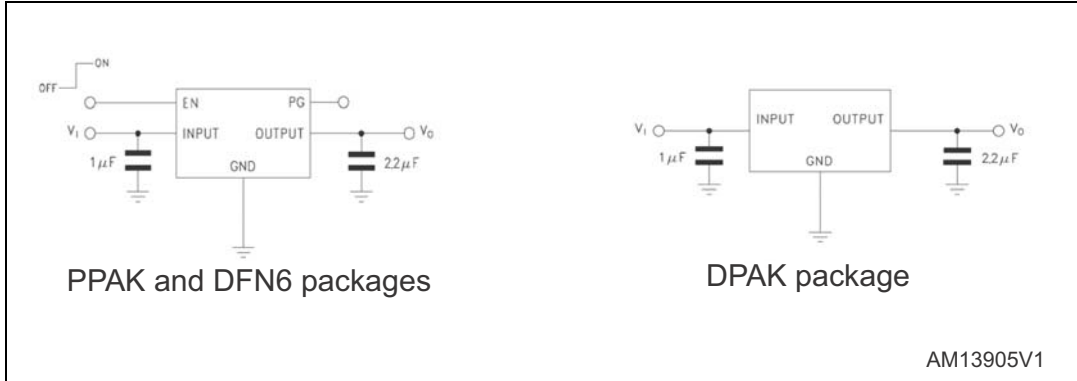
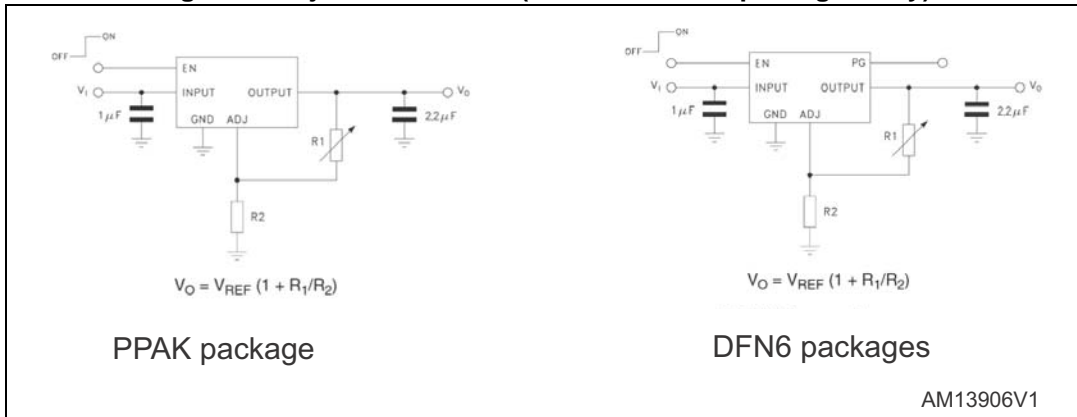

Figure 4. Adjustable version (PPAK and DFN6 packages only)



4 Absolute maximum ratings

Table 3. Absolute maximum ratings

Symbol	Parameter	Value	Unit
V_{IN}	DC input voltage	- 0.3 to 20	V
V_{OUT}	DC output voltage	- 0.3 to $V_{IN} + 0.3$	V
V_{EN}	Enable input voltage	- 0.3 to $V_{IN} + 0.3$	V
V_{ADJ}	Adjust pin voltage	- 0.3 to 2	V
V_{PG}	Power Good pin voltage	- 0.3 to $V_{IN} + 0.3$	V
I_{LOAD}	Output current	Internally limited	mA
P_D	Power dissipation	Internally limited	mW
T_{STG}	Storage temperature range	- 65 to 150	°C
T_{OP}	Operating junction temperature range	- 40 to 125	°C

Note: Absolute maximum ratings are those values beyond which damage to the device may occur. Functional operation under these conditions is not implied. All values are referred to GND.

Table 4. Thermal data

Symbol	Parameter	Value				Unit
		PPAK	DPAK	DFN6-2x2	DFN6-3x3	
R_{thJA}	Thermal resistance junction-ambient	100	100	65	55	°C/W
R_{thJC}	Thermal resistance junction-case	8	8	6.5	10	°C/W

5 Electrical characteristics

$T_J = 25\text{ °C}$, $V_{IN} = V_{OUT(NOM)} + 1\text{ V}^{(1)}$, $C_{IN} = 1\text{ }\mu\text{F}$, $C_{OUT} = 2.2\text{ }\mu\text{F}$, $I_{LOAD} = 10\text{ mA}$, $V_{EN} = 2\text{ V}$, unless otherwise specified.

Table 5. Electrical characteristics for LDFM (fixed versions)

Symbol	Parameter	Test conditions	Min.	Typ.	Max.	Unit
V_{IN}	Operating input voltage		2.5		16	V
V_{OUT}	V_{OUT} accuracy, PPAK and DFN6 versions	$V_{OUT+1}\text{ V}^{(1)} \leq V_{IN} \leq 16\text{ V}$ $I_{LOAD} = 10\text{ mA}$	-1		1	%
		$10\text{ mA} \leq I_{LOAD} \leq 500\text{ mA}$ $T_J = -40\text{ to }125\text{ °C}$	-1.5		1.5	%
V_{OUT}	V_{OUT} accuracy, DPAK version	$V_{OUT+1}\text{ V}^{(1)} \leq V_{IN} \leq 16\text{ V}$ $I_{LOAD} = 10\text{ mA}$	-2		2	%
		$10\text{ mA} \leq I_{LOAD} \leq 500\text{ mA}$ $T_J = -40\text{ to }125\text{ °C}$	-3		3	%
ΔV_{OUT}	Static line regulation	$V_{OUT+1}\text{ V}^{(1)} \leq V_{IN} \leq 16\text{ V}$ $I_{LOAD} = 10\text{ mA}$		0.01		%V
		$V_{OUT+1}\text{ V}^{(1)} \leq V_{IN} \leq 16\text{ V}$, $T_J = -40\text{ to }125\text{ °C}$			0.04	
ΔV_{OUT}	Static load regulation	$10\text{ mA} \leq I_{LOAD} \leq 500\text{ mA}$		0.1		%A
		$10\text{ mA} \leq I_{LOAD} \leq 500\text{ mA}$, $T_J = -40\text{ to }125\text{ °C}$		0.15	0.4	
V_{DROP}	Dropout voltage ⁽²⁾	$I_{LOAD} = 500\text{ mA}$, $-40\text{ °C} < T_J < 125\text{ °C}$		125	300	mV
I_Q	Quiescent current	ON mode: $V_{EN} = 2\text{ V}$ $I_{LOAD} = 10\text{ mA to }500\text{ mA}$, $T_J = -40\text{ to }125\text{ °C}$		200	800	μA
		OFF Mode: $V_{EN} = \text{GND}$, PPAK and DFN versions		30		
		OFF Mode: $V_{EN} = \text{GND}$, PPAK and DFN versions, $-40\text{ °C} < T_J < 125\text{ °C}$			120	
I_{SC}	Short-circuit current			0.8		A
V_{EN}	Enable input logic low	$V_{IN} = 2.5\text{ V to }16\text{ V}$, $-40\text{ °C} < T_J < 125\text{ °C}$			0.8	V
	Enable input logic high		2			
I_{EN}	Enable pin input current	$V_{EN} = V_{IN}$		5	10	μA
PG	Power Good output threshold	Rising edge		0.92*		V
		Falling edge		0.8*		
	Power Good output voltage low	$I_{SINK} = 6\text{ mA}$, open drain output		0.4		

Table 5. Electrical characteristics for LDFM (fixed versions) (continued)

Symbol	Parameter	Test conditions	Min.	Typ.	Max.	Unit
SVR	Supply voltage rejection	$V_{IN} = 6\text{ V} \pm 0.5 V_{RIPPLE}$ Freq. = 120 Hz, $V_{OUT} = 5\text{ V}$		60		dB
		$V_{IN} = 6\text{ V} \pm 0.5 V_{RIPPLE}$ Freq. = 10 kHz, $V_{OUT} = 5\text{ V}$		52		
e_N	Output noise voltage	Bw = 10 Hz to 100 kHz, $I_{LOAD} = 100\text{ mA}$, $C_{OUT} = 2.2\text{ }\mu\text{F}$		45		μV_{RMS} V_{OUT}
T_{SHDN}	Thermal shutdown			170		°C
	Hysteresis			10		

1. For $V_{OUT} < 1.5\text{ V}$; $V_{IN} = 2.5\text{ V}$
2. Dropout voltage is the input-to-output voltage difference at which the output voltage is 100 mV below its nominal value. This specification does not apply for output voltages below 1.5 V.

$T_J = 25\text{ }^\circ\text{C}$, $V_{IN} = V_{OUT(NOM)} + 1\text{ V}^{(1)}$, $C_{IN} = 1\text{ }\mu\text{F}$, $C_{OUT} = 2.2\text{ }\mu\text{F}$, $I_{LOAD} = 10\text{ mA}$, $V_{EN} = 2\text{ V}$, unless otherwise specified.

Table 6. Electrical characteristics for LDFM (adjustable version)

Symbol	Parameter	Test conditions	Min.	Typ.	Max.	Unit
V_{IN}	Operating input voltage		2.5		16	V
V_{ADJ}	Reference voltage	$V_{IN} = V_{OUT} + 1\text{ V}^{(1)}$		0.8		V
	Reference voltage tolerance	$V_{OUT} + 1\text{ V}^{(1)} \leq V_{IN} \leq 16\text{ V}$ $I_{LOAD} = 10\text{ mA}$	-1		1	%
$10\text{ mA} \leq I_{LOAD} \leq 500\text{ mA}$ $T_J = -40\text{ to }125\text{ }^\circ\text{C}$		-1.5		1.5		
ΔV_{OUT}	Static line regulation	$V_{OUT} + 1\text{ V}^{(1)} \leq V_{IN} \leq 16\text{ V}$		0.01		%V
		$V_{OUT} + 1\text{ V}^{(1)} \leq V_{IN} \leq 16\text{ V}$, $T_J = -40\text{ to }125\text{ }^\circ\text{C}$			0.04	
ΔV_{OUT}	Static load regulation	$10\text{ mA} \leq I_{LOAD} \leq 500\text{ mA}$		0.06		%A
		$10\text{ mA} \leq I_{LOAD} \leq 500\text{ mA}$, $T_J = -40\text{ to }125\text{ }^\circ\text{C}$		0.2	0.4	
V_{DROP}	Dropout voltage ⁽²⁾	V_{OUT} fixed to 2.5 V, $I_{LOAD} = 500\text{ mA}$, $-40\text{ }^\circ\text{C} < T_J < 125\text{ }^\circ\text{C}$		125	300	mV
I_Q	Quiescent current	ON mode: $V_{EN} = 2\text{ V}$ $I_{LOAD} = 10\text{ mA to }500\text{ mA}$, $T_J = -40\text{ to }125\text{ }^\circ\text{C}$		200	800	μA
		OFF Mode: $V_{EN} = \text{GND}$, PPAK and DFN versions		30		
		OFF Mode: $V_{EN} = \text{GND}$, PPAK and DFN versions, $-40\text{ }^\circ\text{C} < T_J < 125\text{ }^\circ\text{C}$			120	
I_{SC}	Short-circuit current			0.8		A
V_{EN}	Enable input logic low	$V_{IN} = 2.5\text{ V to }16\text{ V}$, $-40\text{ }^\circ\text{C} < T_J < 125\text{ }^\circ\text{C}$			0.8	V
	Enable input logic high		2			
I_{EN}	Enable pin input current	$V_{EN} = V_{IN}$		5	10	μA
PG	Power Good output threshold	Rising edge		0.92*		V
		Falling edge		0.8*		
	Power Good output voltage low	$I_{SINK} = 6\text{ mA}$, open drain output		0.4		
SVR	Supply voltage rejection	$V_{IN} = V_{OUT} + 1\text{ V} \pm 0.5\text{ }V_{RIPPLE}$ Freq. = 120 Hz, $V_{OUT} = 0.8\text{ V}$		62		dB
		$V_{IN} = V_{OUT} + 1\text{ V} \pm 0.5\text{ }V_{RIPPLE}$ Freq. = 10 kHz, $V_{OUT} = 0.8\text{ V}$		55		
e_N	Output noise voltage	Bw = 10 Hz to 100 kHz, $I_{LOAD} = 100\text{ mA}$, $C_{OUT} = 2.2\text{ }\mu\text{F}$		50		μV_{RMS} $\sqrt{V_{OUT}}$

Table 6. Electrical characteristics for LDFM (adjustable version) (continued)

Symbol	Parameter	Test conditions	Min.	Typ.	Max.	Unit
T_{SHDN}	Thermal shutdown			170		°C
	Hysteresis			10		

1. For $V_{\text{OUT}} < 1.5 \text{ V}$; $V_{\text{IN}} = 2.5 \text{ V}$.
2. Dropout voltage is the input-to-output voltage difference at which the output voltage is 100 mV below its nominal value. This specification does not apply for output voltages below 1.5 V.

6 Application information

6.1 External capacitors

The LDFM requires external capacitors for regulator stability. These capacitors must be selected to meet the requirements of minimum capacitance and equivalent series resistance (see [Figure 25 and 26](#)). It is advisable to locate the input/output capacitors as close as possible to the relative pins.

6.1.1 Input capacitor

An input capacitor with a minimum value of 1 μF is required with the LDFM. This capacitor must be located a distance of not more than 0.5" from the input pin of the device and returned to a clean analog ground. Any good quality ceramic capacitors can be used for this capacitor.

6.1.2 Output capacitor

It is possible to use ceramic capacitors but the output capacitor must meet the requirements for minimum amount of capacitance and E.S.R. (equivalent series resistance) value.

A minimum capacitance of 2.2 μF is a good choice to guarantee the stability of the regulator. However, other C_{OUT} values can be used according to [Figure 25 and 26](#), showing the allowable ESR range as a function of the output capacitance.

The output capacitor must maintain its ESR in the stable region over the full operating temperature range to assure stability. Also, capacitor tolerance and variation with temperature must be kept in consideration in order to assure the minimum amount of capacitance at all times.

6.2 Enable pin operation

The Enable pin can be used to turn OFF the regulator when pulled down, so drastically reducing the current consumption. When the enable feature is not used, this pin must be tied to V_{IN} to keep the regulator output ON at all times. To assure proper operation, the signal source used to drive the Enable pin must be able to swing above and below the specified thresholds listed in the electrical characteristics section (V_{EN}). The Enable pin must not be left floating because it is not internally pulled down/up.

6.3 Power Good

The LDFM features an open drain Power Good (PG) pin to sequence external supplies or loads and to provide fault detection. This pin requires an external resistor (R_{PG}) to pull PG high when the output is within the PG tolerance window. Typical values for this resistor range from 10 k Ω to 100 k Ω .

7 Typical performance characteristics

$C_{IN} = C_{OUT} = 1 \mu F$, $V_{IN} = V_{OUT} + 1 V$, V_{EN} to V_{IN} , $I_{OUT} = 10 mA$, unless otherwise specified.

Figure 5. Output voltage vs. temperature

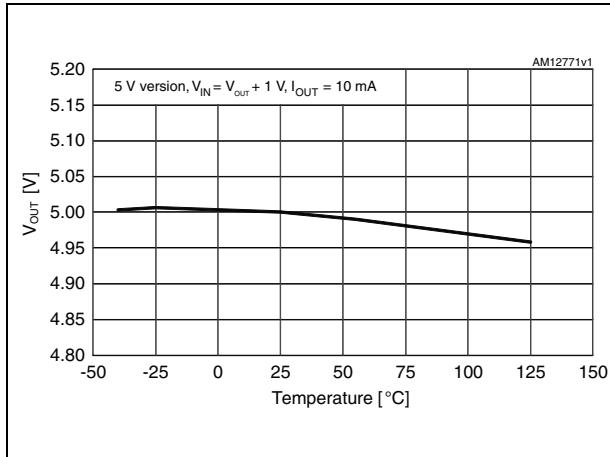

Figure 6. Output voltage vs. temperature for adjustable

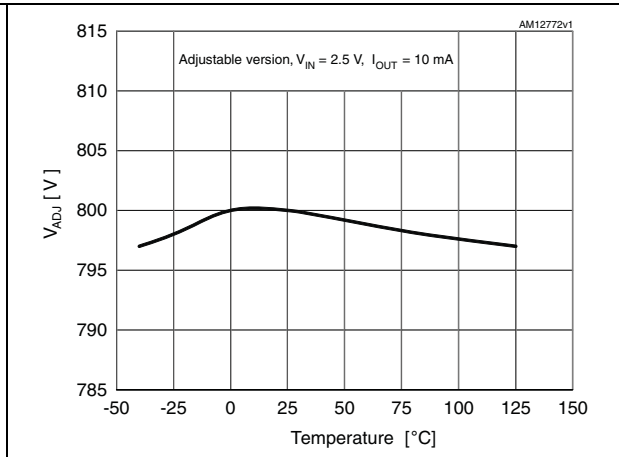

Figure 7. Line regulation vs. temperature

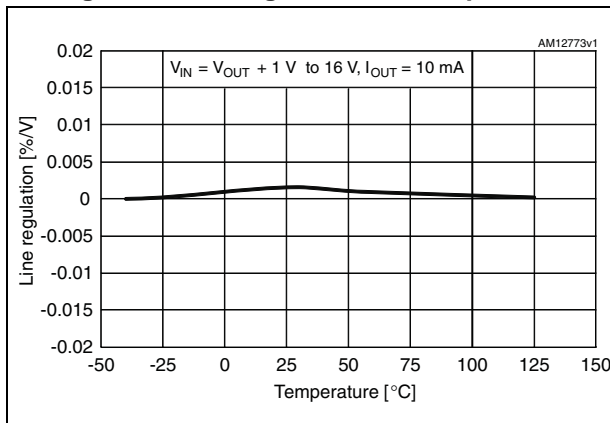

Figure 8. Load regulation vs. temperature

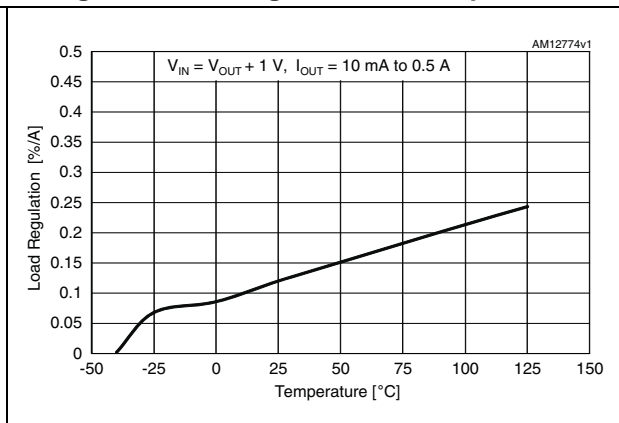

Figure 9. Short-circuit current vs. drop voltage

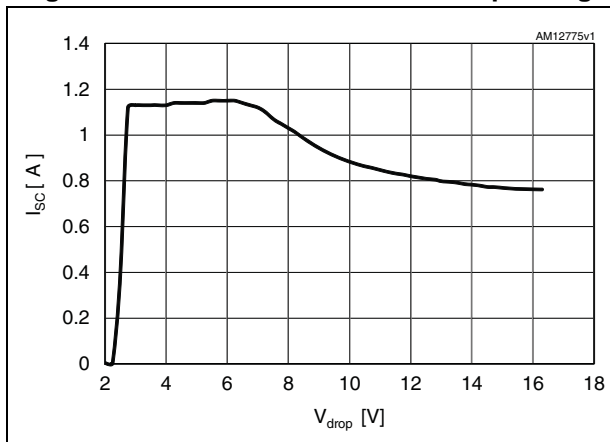

Figure 10. Dropout voltage vs. temperature

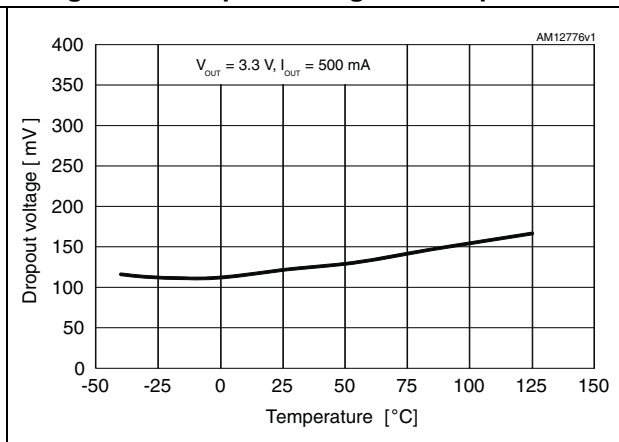

Figure 11. Quiescent current vs. temperature
($I_{OUT} = 10 \text{ mA}$)

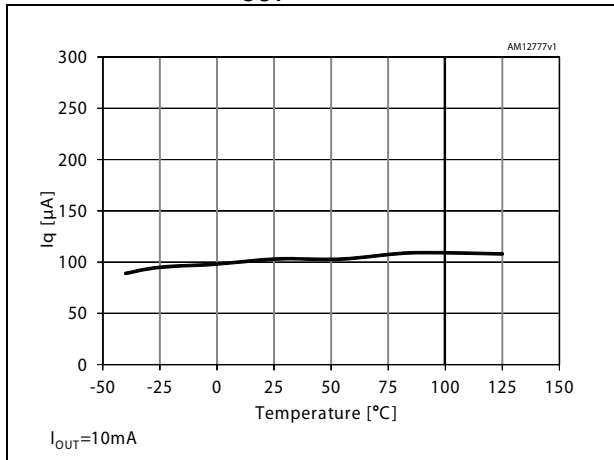

Figure 12. Quiescent current vs. temperature
($I_{OUT} = 500 \text{ mA}$)

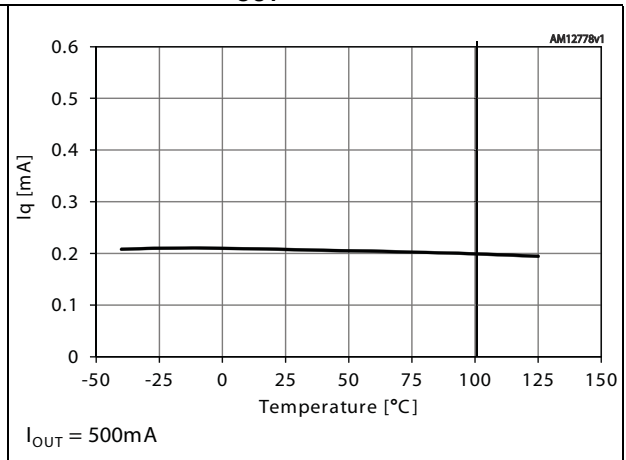

Figure 13. Shutdown current vs. temperature

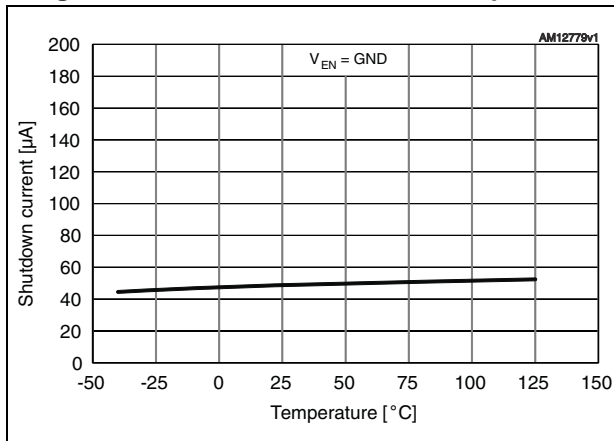

Figure 14. Enable pin current vs. temperature

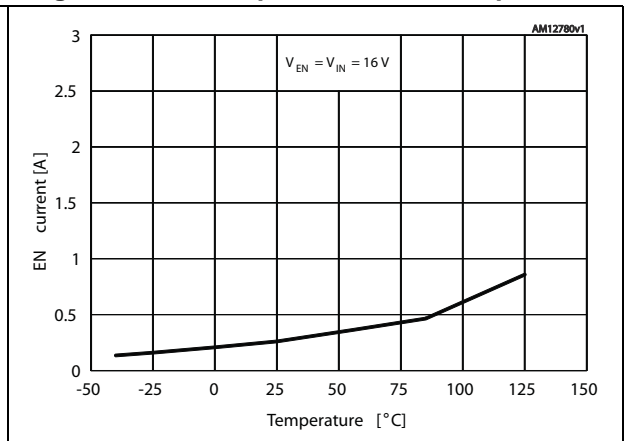

Figure 15. Enable high threshold vs. temperature

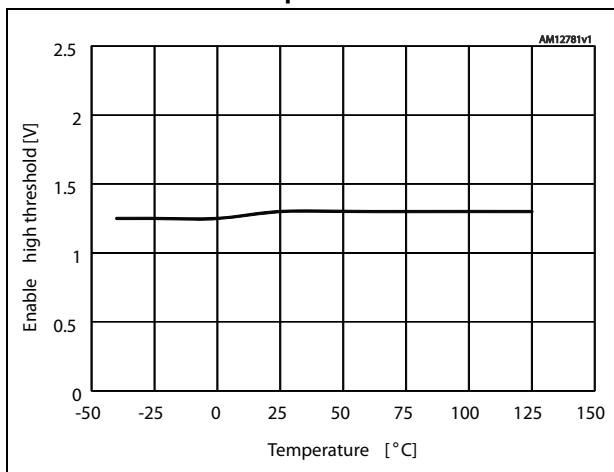

Figure 16. Enable low threshold vs. temperature

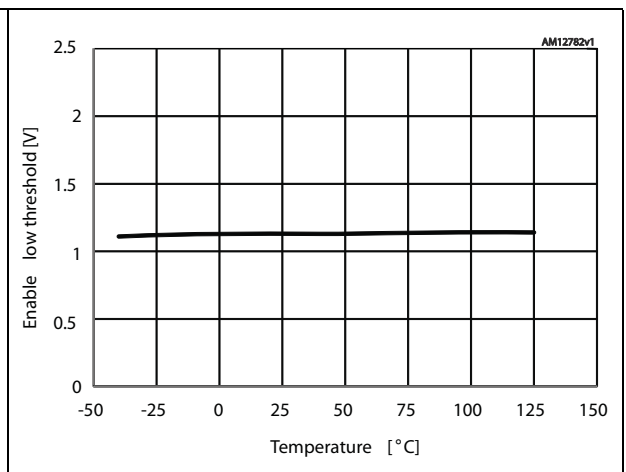

Figure 17. Output voltage vs. input voltage

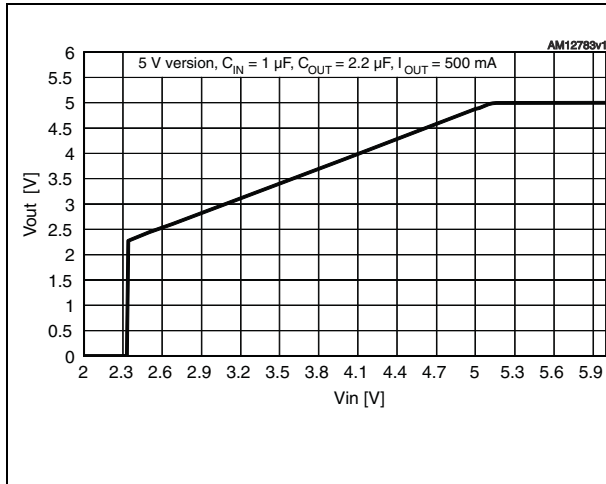

Figure 18. Line transient

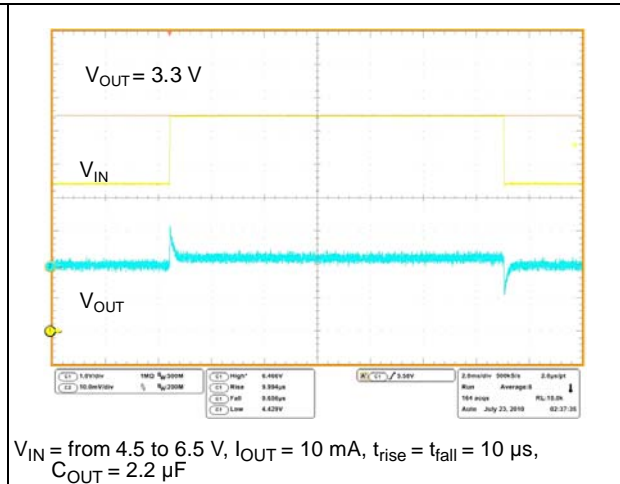

Figure 19. Load transient ($V_{OUT} = 3.3\text{ V}$)

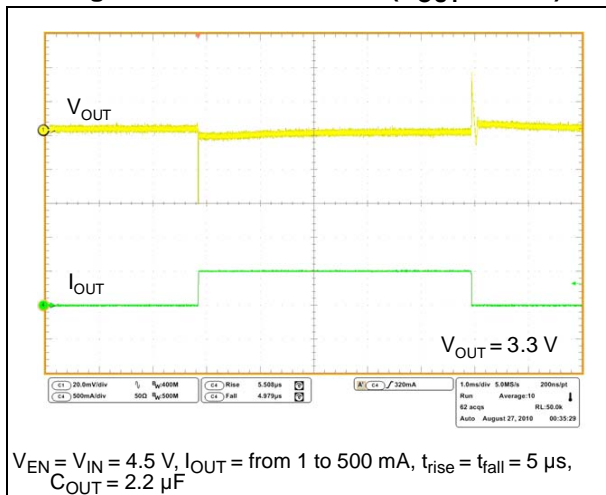

Figure 20. Load transient ($V_{OUT} = V_{ADJ}$)

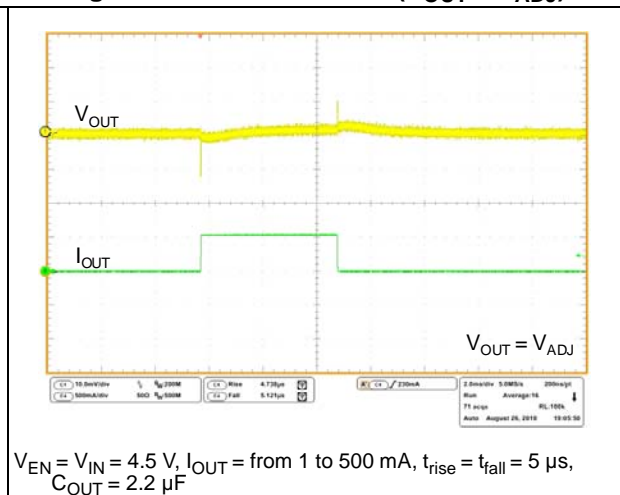

Figure 21. Startup transient

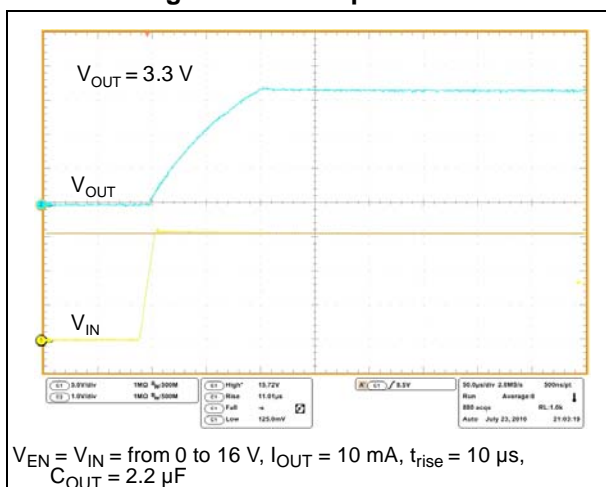

Figure 22. Enable transient

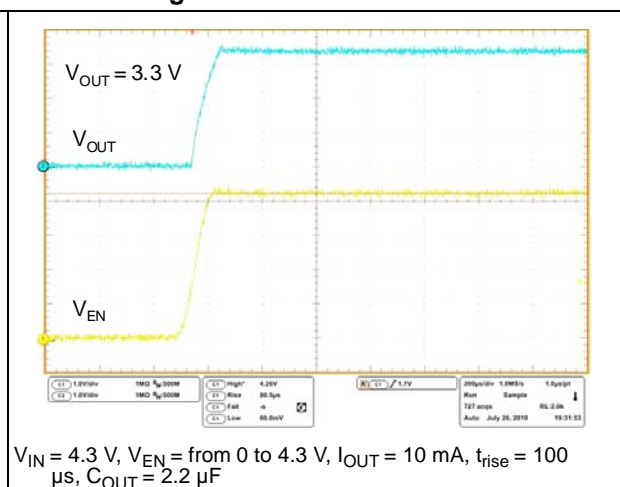

Figure 23. SVR vs. frequency ($V_{OUT} = 5\text{ V}$)

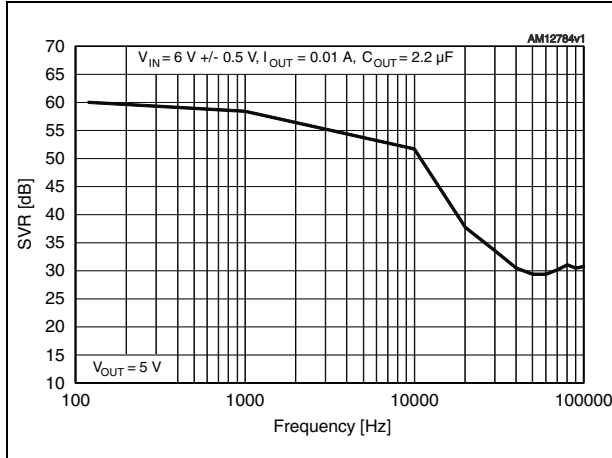

Figure 24. SVR vs. frequency ($V_{OUT} = V_{ADJ}$)

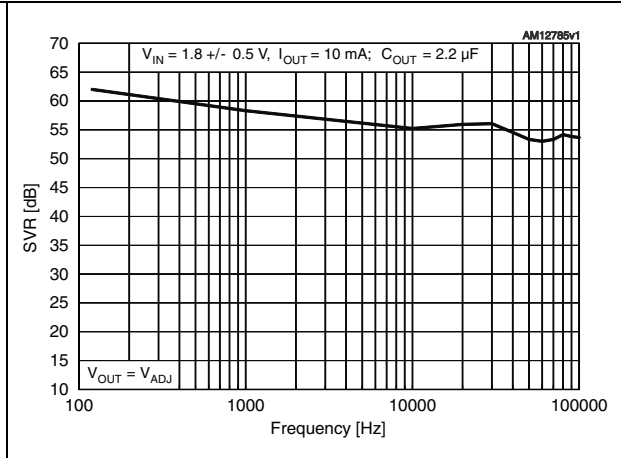

Figure 25. Stability plane adj (C_{OUT} , ESR)

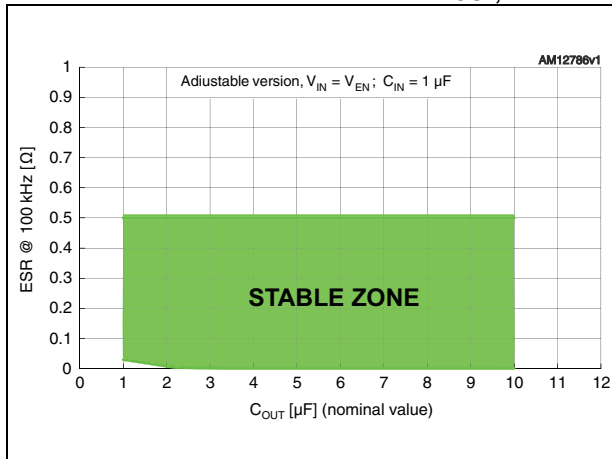
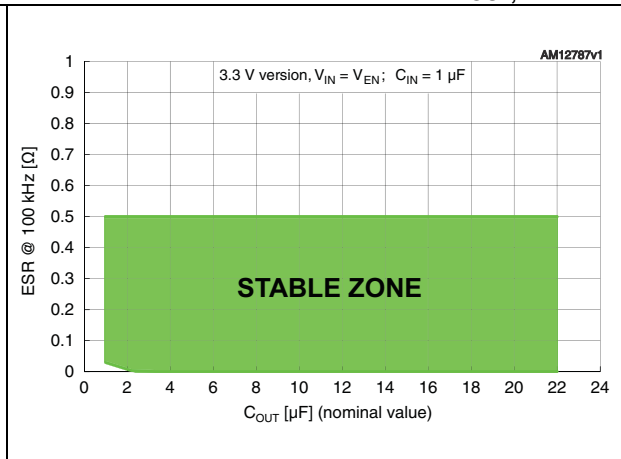

Figure 26. Stability plane 3.3 V (C_{OUT} , ESR)



8 Package mechanical data

In order to meet environmental requirements, ST offers these devices in different grades of ECOPACK[®] packages, depending on their level of environmental compliance. ECOPACK specifications, grade definitions and product status are available at: www.st.com. ECOPACK is an ST trademark.

Table 7. DPAK mechanical data

Dim.	mm		
	Min.	Typ.	Max.
A	2.20		2.40
A1	0.90		1.10
A2	0.03		0.23
b	0.64		0.90
b4	5.20		5.40
c	0.45		0.60
c2	0.48		0.60
D	6.00		6.20
D1		5.10	
E	6.40		6.60
E1		4.70	
e		2.28	
e1	4.40		4.60
H	9.35		10.10
L	1.00		1.50
(L1)		2.80	
L2		0.80	
L4	0.60		1.00
R		0.20	
V2	0°		8°

Figure 27. DPAK drawing

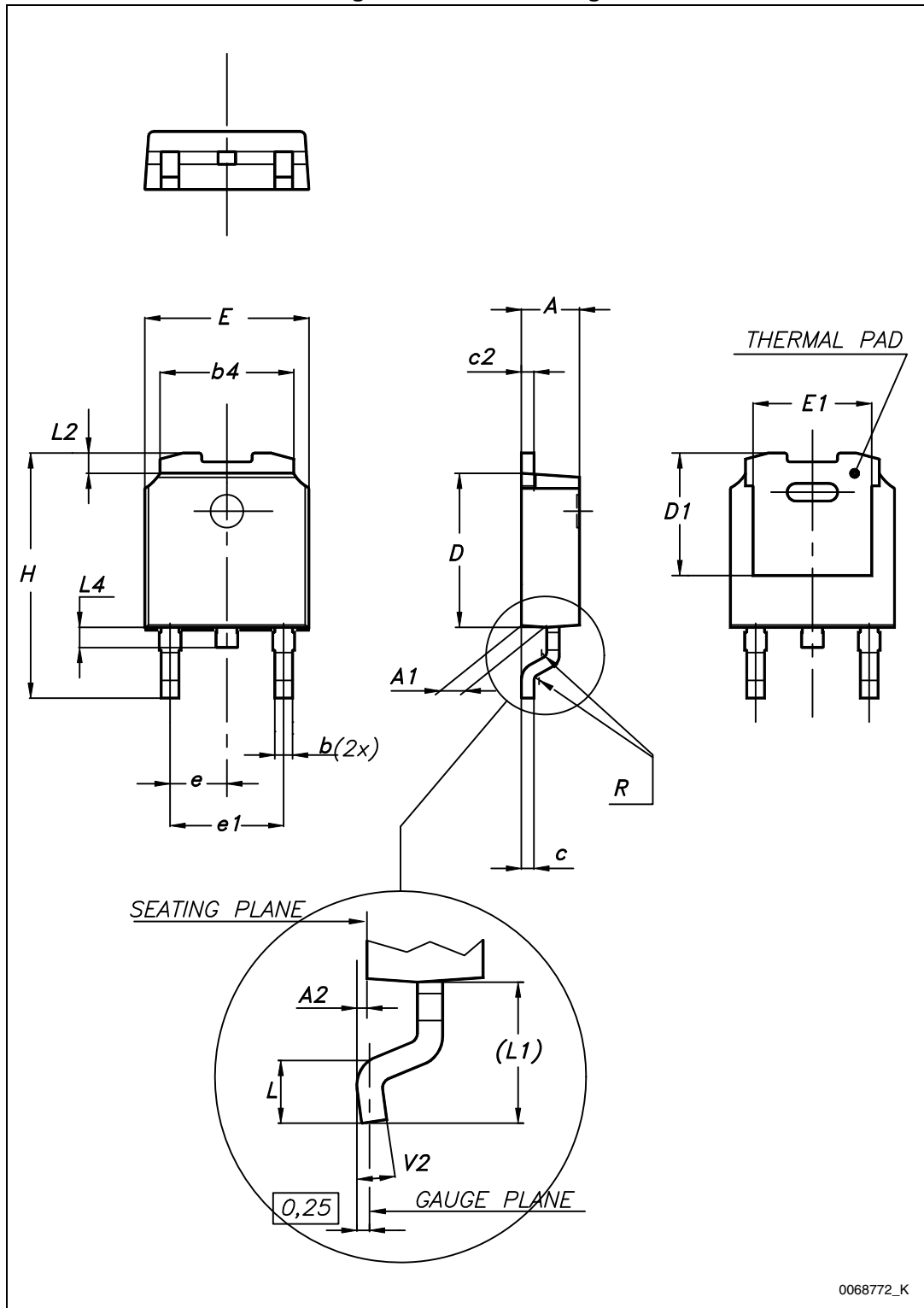
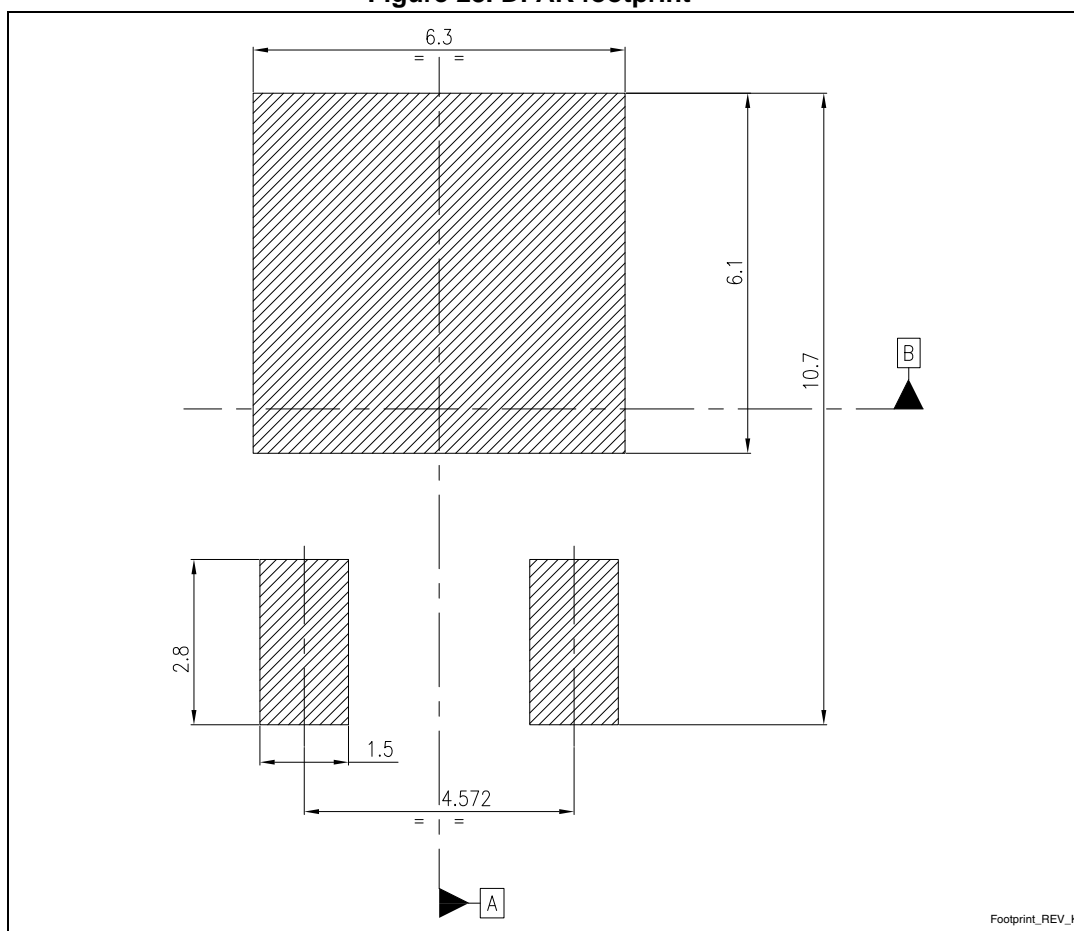

Figure 28. DPAK footprint (a)



Footprint_REV_K

a. All dimensions are in millimeters.

Table 8. PPAK mechanical data

Dim.	mm		
	Min.	Typ.	Max.
A	2.2		2.4
A1	0.9		1.1
A2	0.03		0.23
B	0.4		0.6
B2	5.2		5.4
C	0.45		0.6
C2	0.48		0.6
D	6		6.2
D1		5.1	
E	6.4		6.6
E1		4.7	
e		1.27	
G	4.9		5.25
G1	2.38		2.7
H	9.35		10.1
L2		0.8	1
L4	0.6		1
L5	1		
L6		2.8	
R		0.20	
V2	0°		8°

Figure 29. PPAK drawings

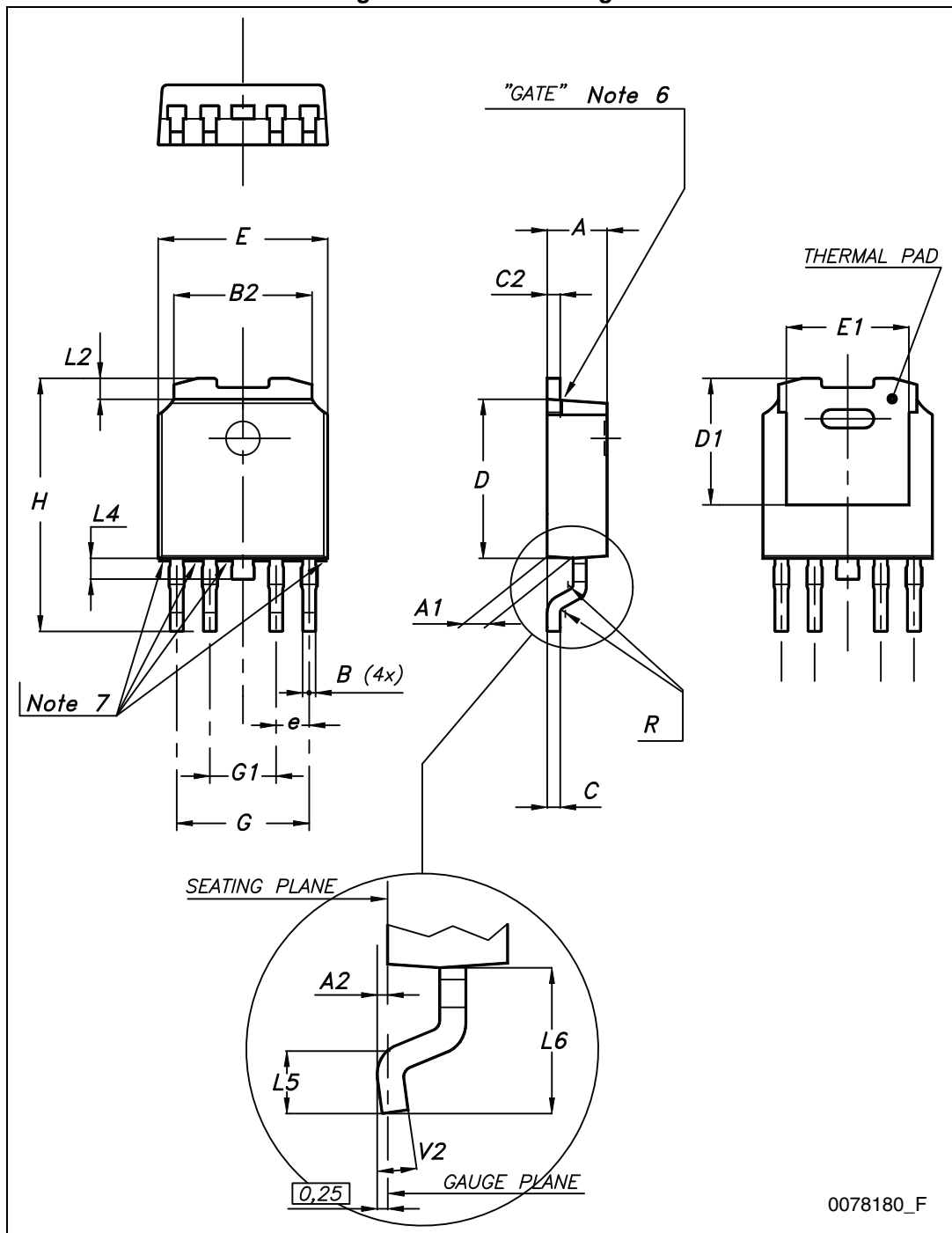

Table 9. DFN6 (3 x 3 mm) mechanical data

Dim.	mm		
	Min.	Typ.	Max.
A	0.80		1
A1	0	0.02	0.05
A3		0.20	
b	0.23		0.45
D	2.90	3	3.10
D2	2.23		2.50
E	2.90	3	3.10
E2	1.50		1.75
e		0.95	
L	0.30	0.40	0.50

Figure 30. DFN6 (3 x 3 mm) drawings

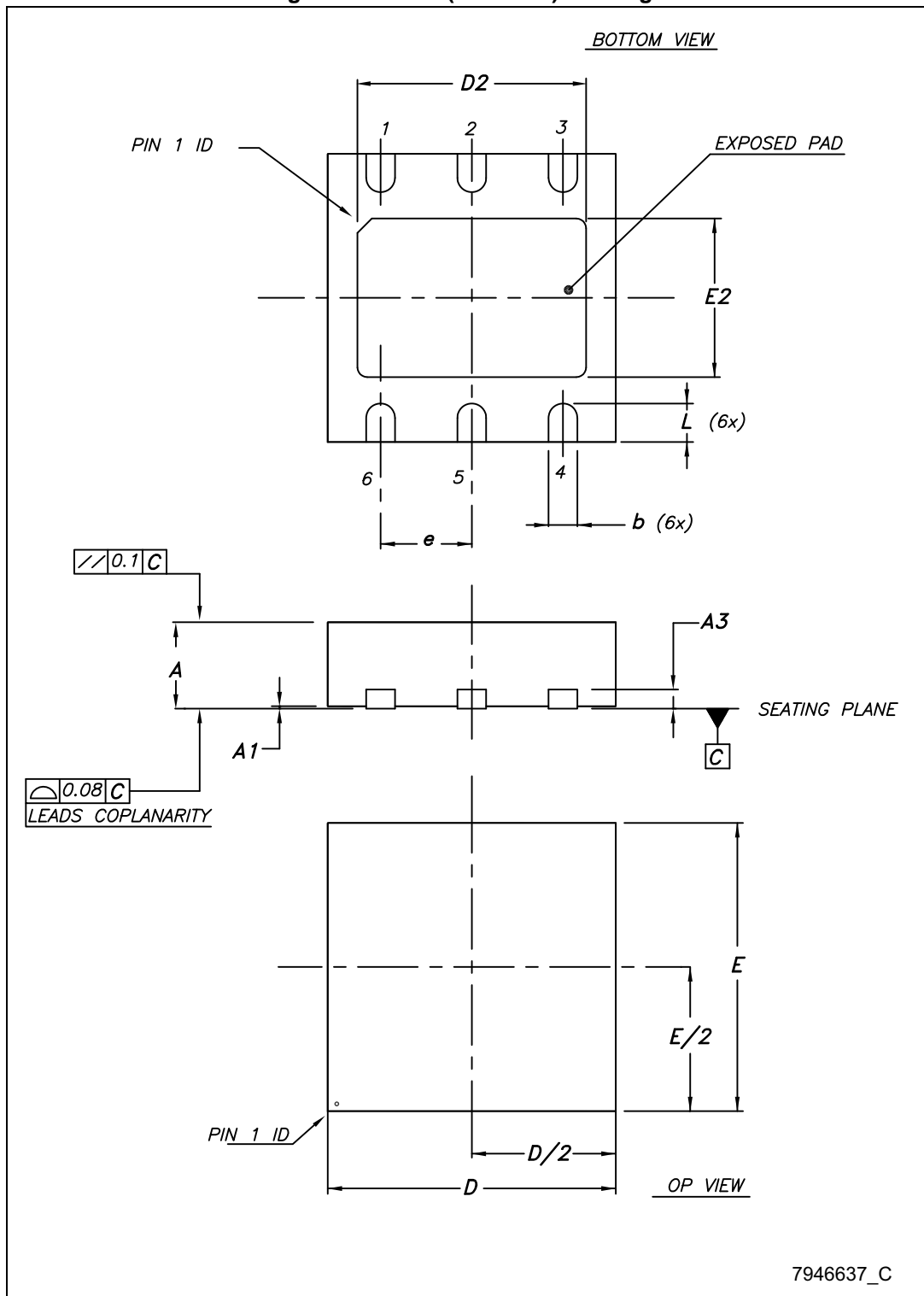

Figure 31. DFN6 (3 x 3 mm) footprint

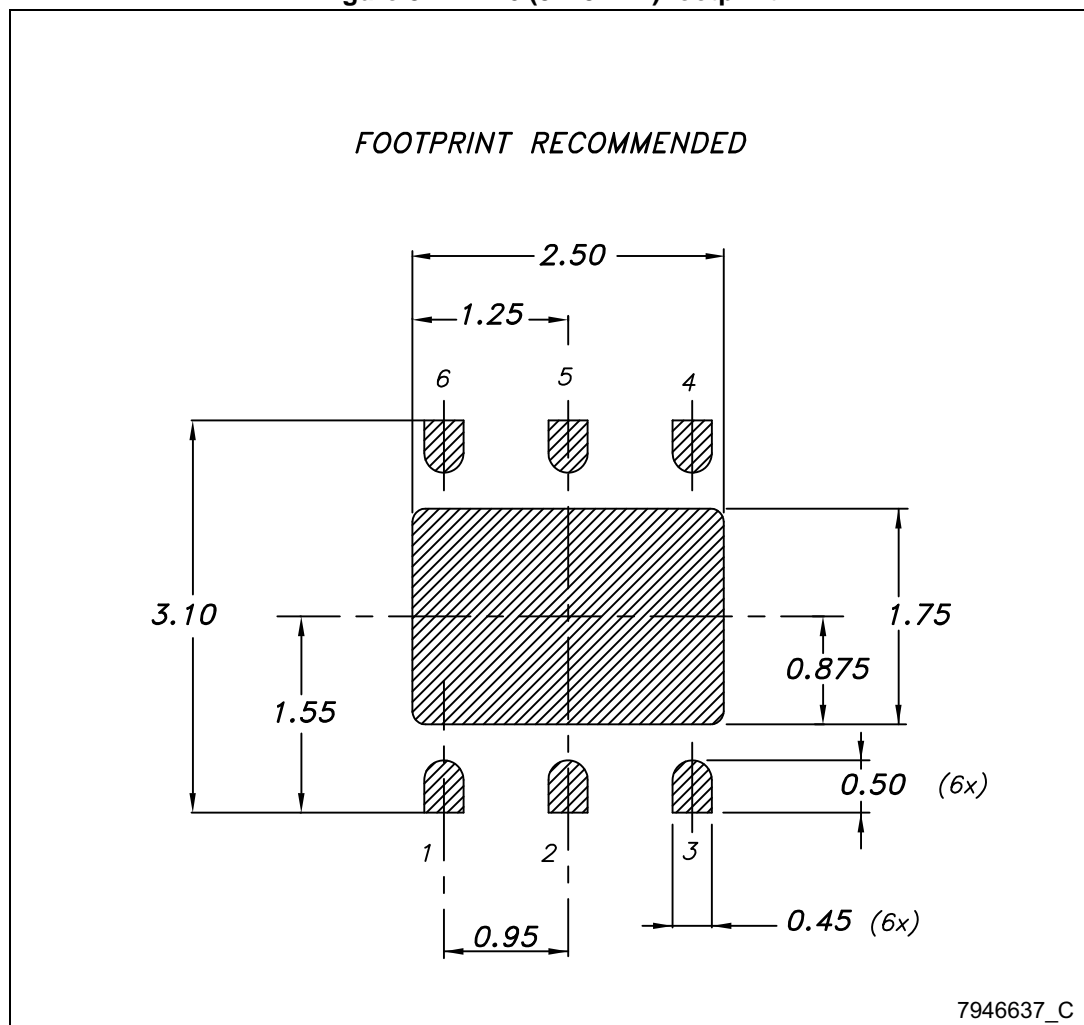

Table 10.DFN6 (2 x 2 mm) mechanical data

Dim.	mm		
	Min.	Typ.	Max.
A	0.80	0.90	1.00
A1	0.00	0.02	0.05
b	0.25	0.30	0.35
D	2.00 BSC		
E	2.00 BSC		
e	0.65 BSC		
D2	1.45	1.60	1.70
E2	0.85	1.00	1.10
L	0.20	0.25	0.30
K	0.15		
aaa	0.05		
bbb	0.10		
ccc	0.10		
ddd	0.05		
eee	0.08		
N	6		

Figure 32. DFN6 (2 x 2 mm) drawings

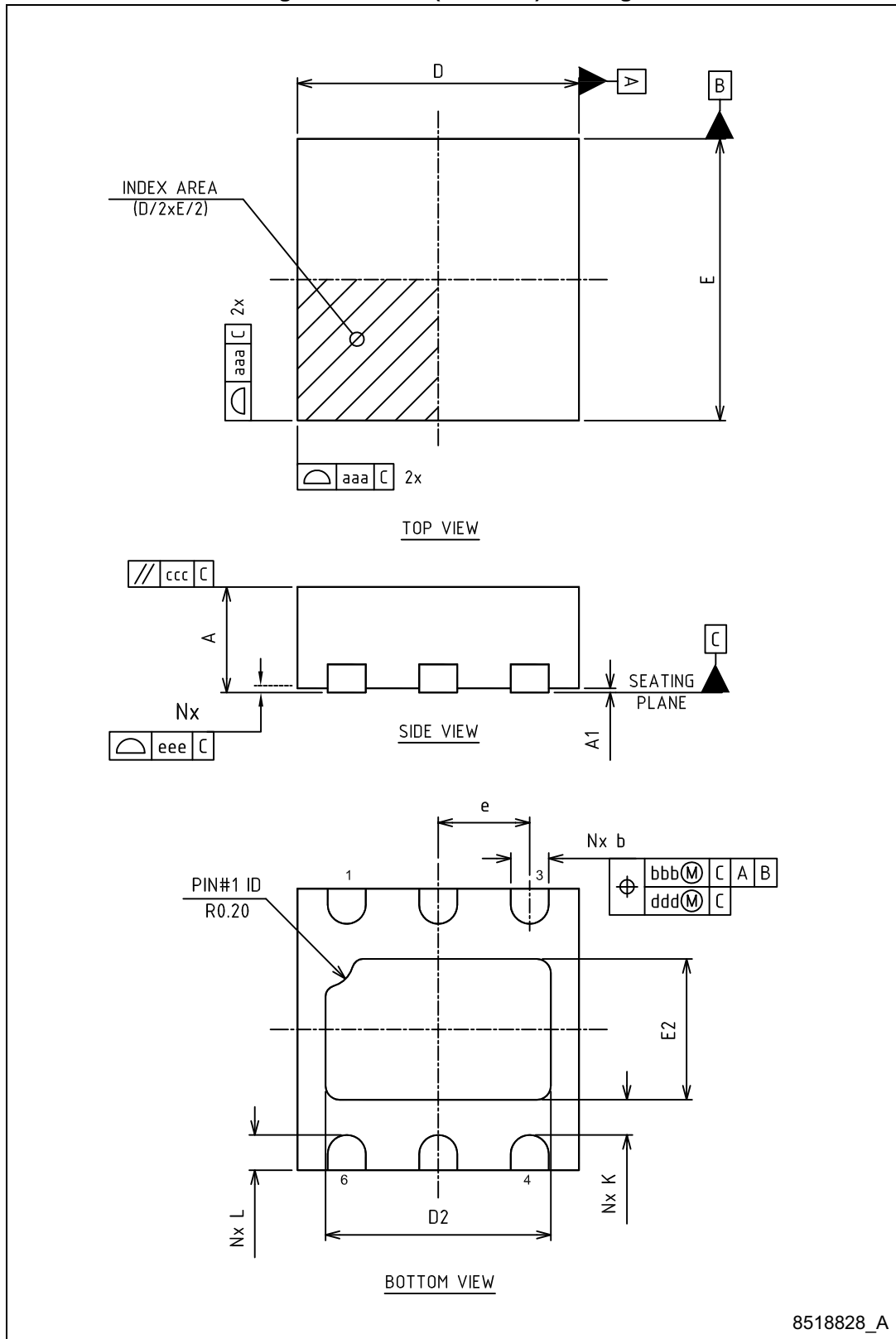
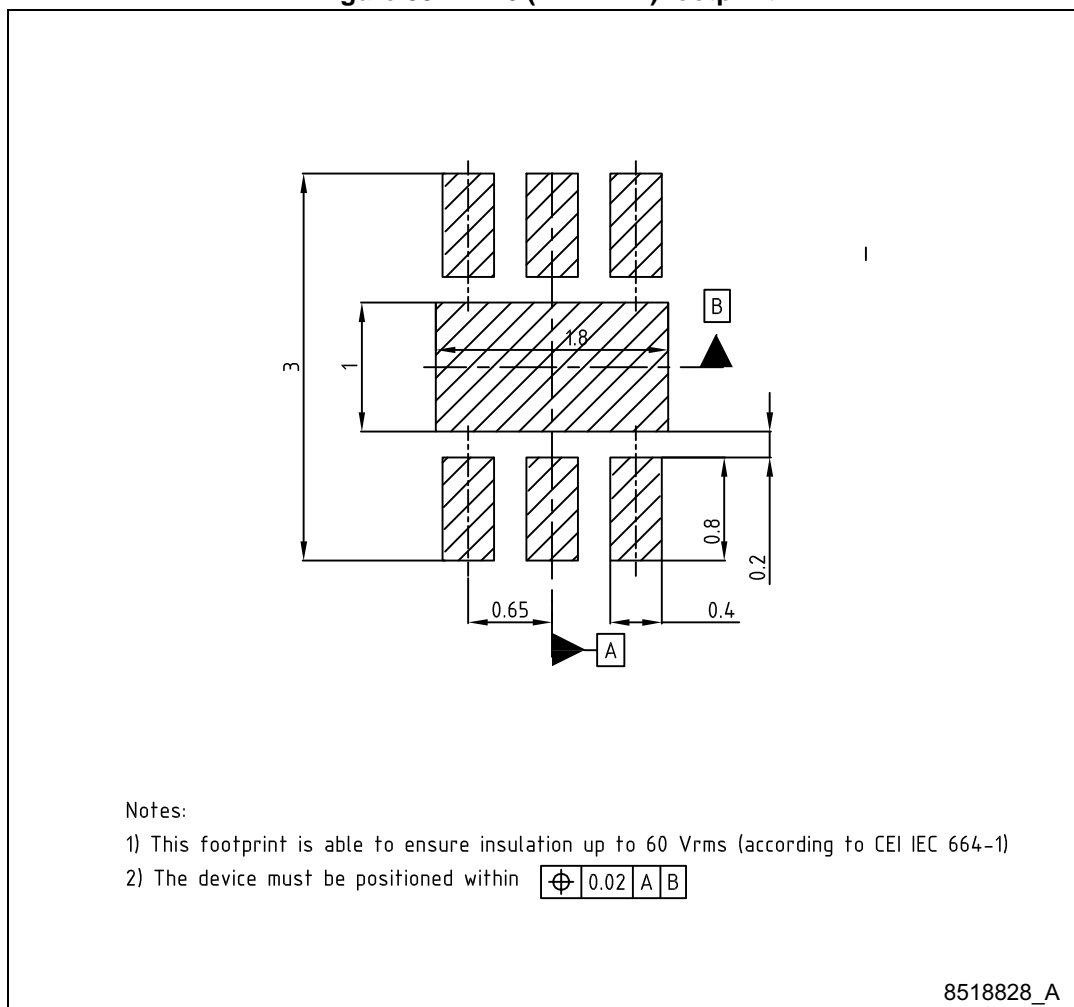

Figure 33. DFN6 (2 x 2 mm) footprint



9 Packaging mechanical data

Table 11. PPAK and DPAK tape and reel mechanical data

Tape			Reel		
Dim.	mm		Dim.	mm	
	Min.	Max.		Min.	Max.
A0	6.8	7	A		330
B0	10.4	10.6	B	1.5	
B1		12.1	C	12.8	13.2
D	1.5	1.6	D	20.2	
D1	1.5		G	16.4	18.4
E	1.65	1.85	N	50	
F	7.4	7.6	T		22.4
K0	2.55	2.75			
P0	3.9	4.1	Base qty.		2500
P1	7.9	8.1	Bulk qty.		2500
P2	1.9	2.1			
R	40				
T	0.25	0.35			
W	15.7	16.3			

Figure 34. Tape for PPAK and DPAK

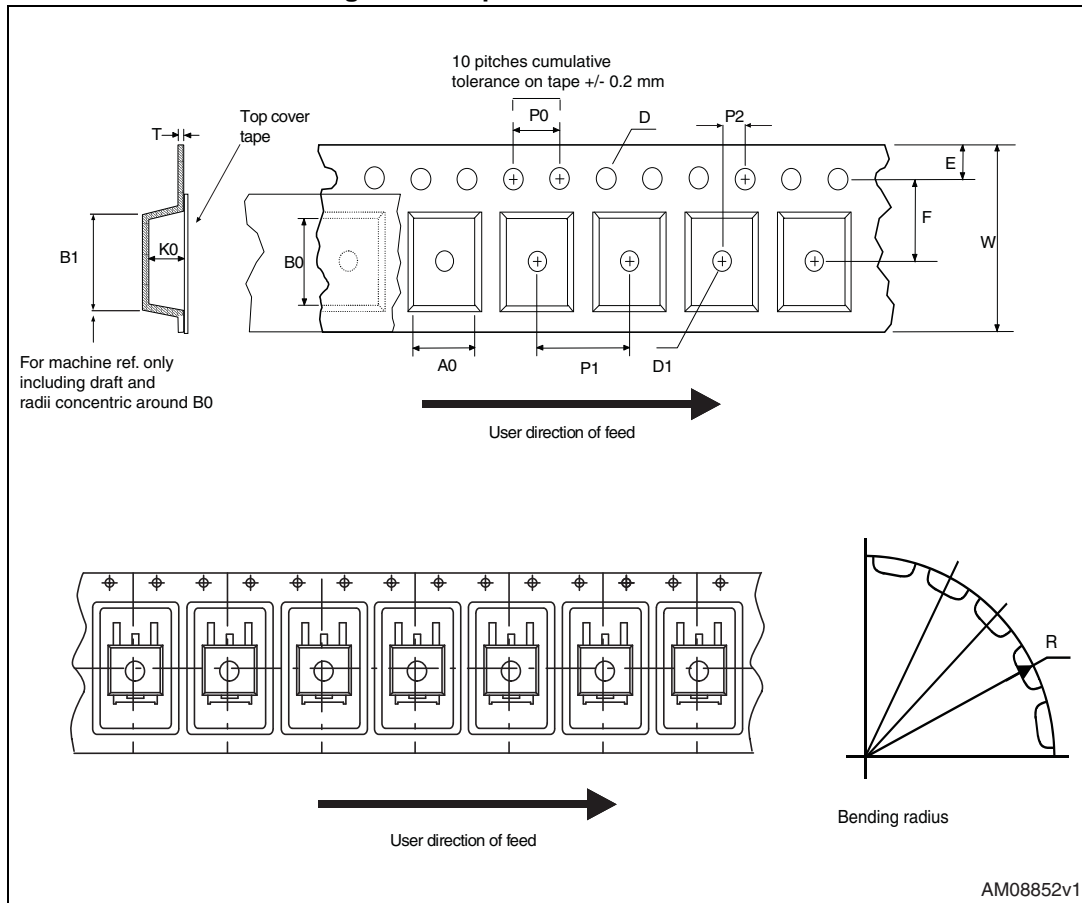

Figure 35. Reel for PPAK and DPAK

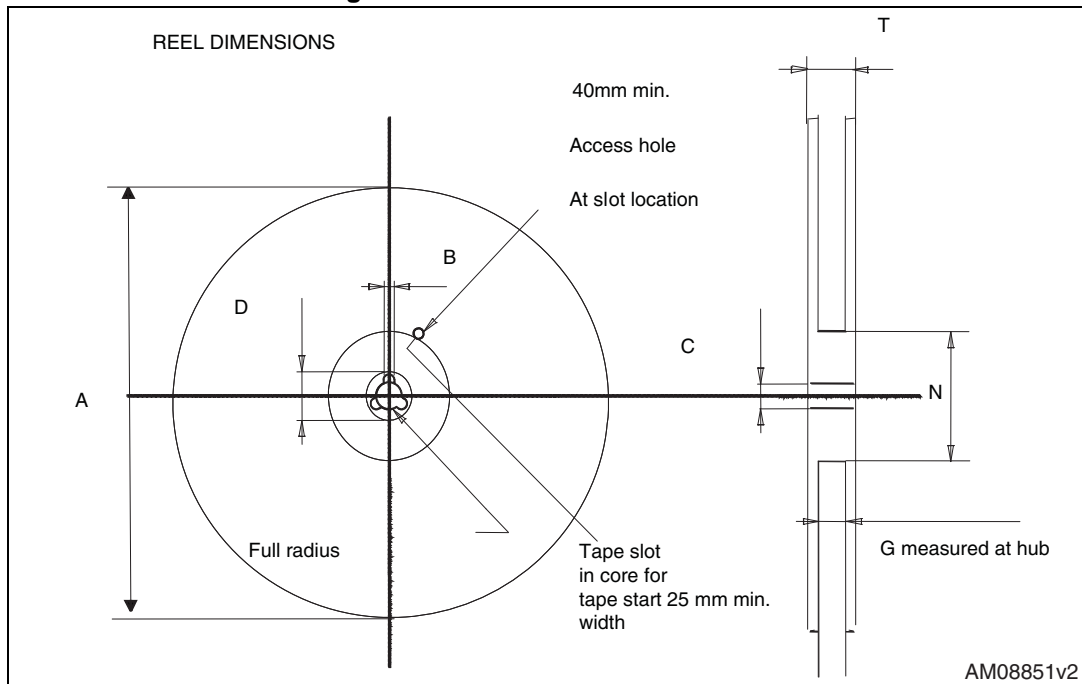

Table 12. DFN6 (3 x 3 mm) tape and reel mechanical data

Dim.	mm		
	Min.	Typ.	Max.
A0	3.20	3.30	3.40
B0	3.20	3.30	3.40
K0	1	1.10	1.20

Figure 36. Tape for DFN6 (3 x 3 mm)

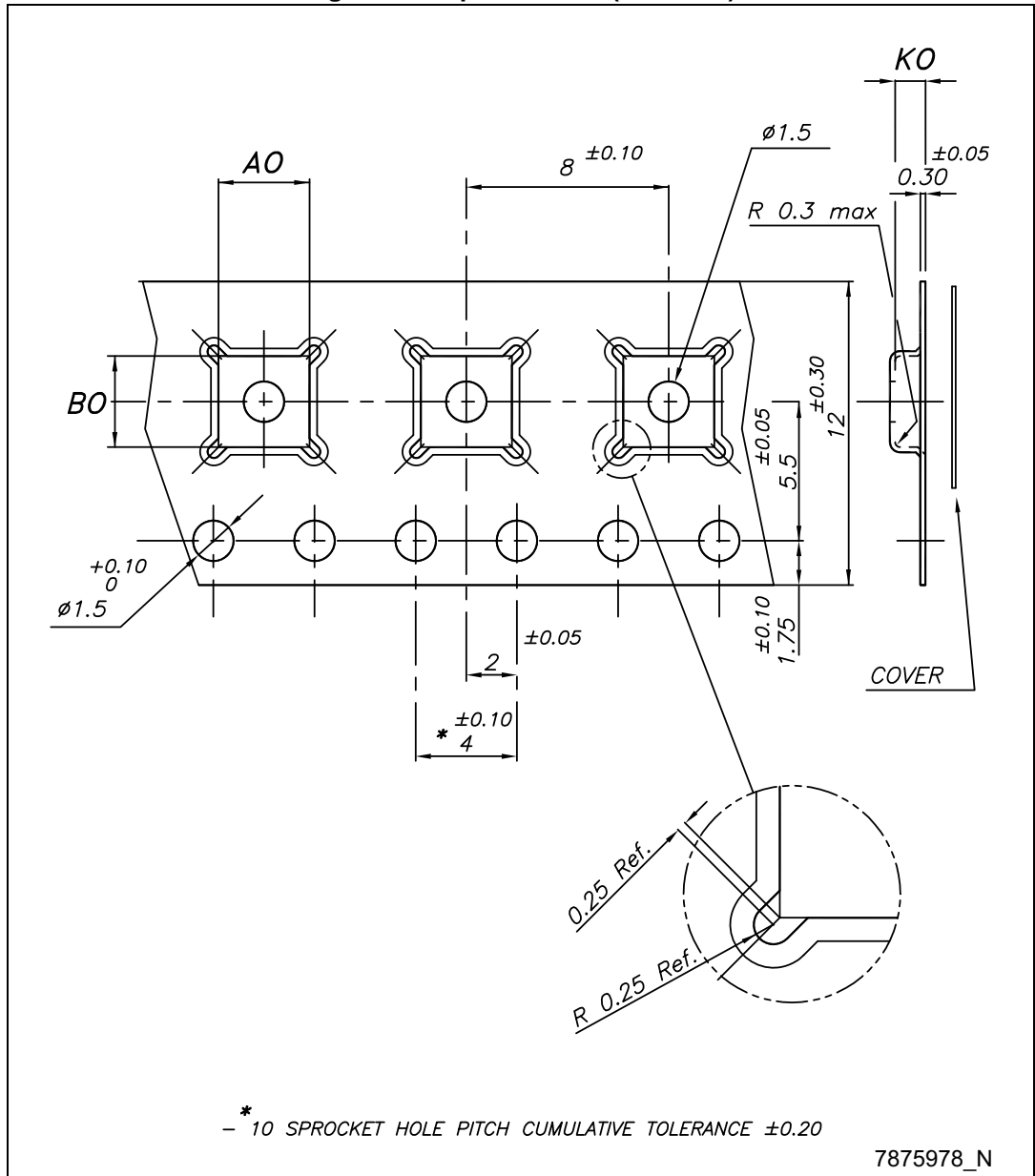

Figure 37. Reel for DFN6 (3 x 3 mm)

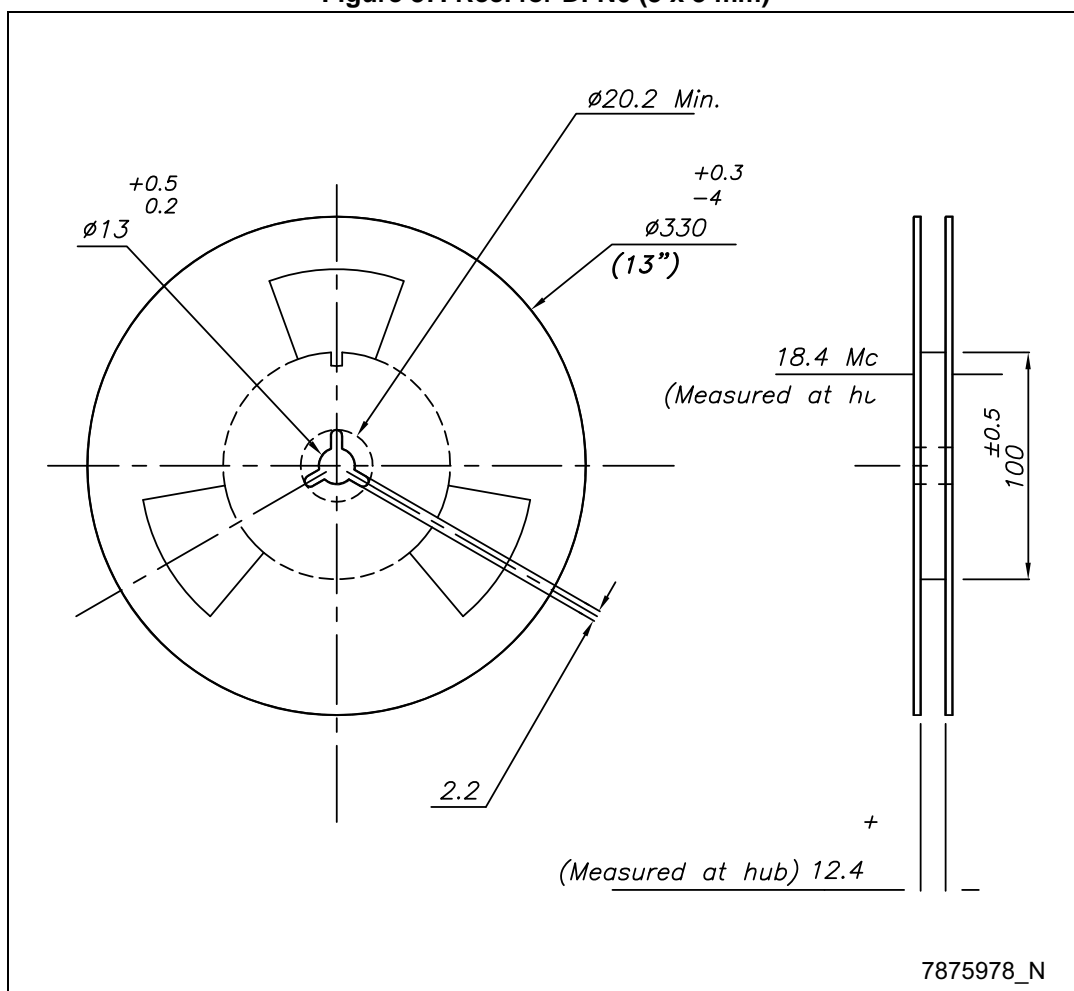
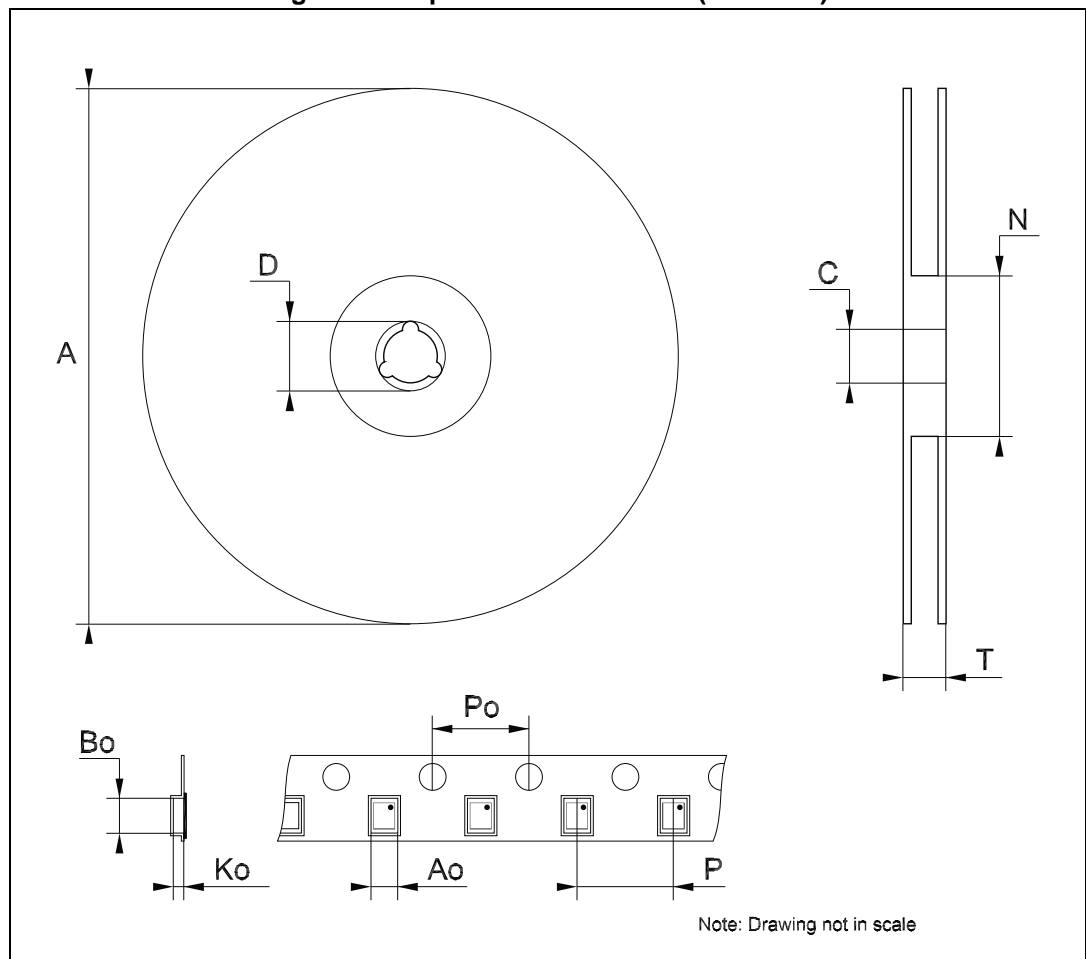

Table 13. DFN6 (2 x 2 mm) tape and reel mechanical data

Dim.	mm		
	Min.	Typ.	Max.
A			180
C	12.8		13.2
D	20.2		
N	60		
T			14.4
Ao		2.4	
Bo		2.4	
Ko		1.3	
Po		4	
P		4	

Figure 38. Tape and reel for DFN6 (2 x 2 mm)



10 Order codes

Table 14. Device summary

Order codes	Packages	Output voltages
LDFMPT-TR	PPAK	Adjustable from 0.8 V
LDFMPUR	DFN6-3x3	
LDFMPVR	DFN6-2x2	
LDFM50DT-TR	DPAK	5 V
LDFM50PT-TR	PPAK	

11 Revision history

Table 15. Document revision history

Date	Revision	Changes
28-Aug-2012	1	Initial release.
22-Nov-2013	2	Part numbers LDFM and LDFM50 have been unified under LDFM. Updated the Features and the Description in cover page. Cancelled Table1: Device summary. Updated Section 2: Pin configuration , Section 3: Typical application , Section 4: Absolute maximum ratings , Section 5: Electrical characteristics and Section 8: Package mechanical data . Added Section 9: Packaging mechanical data and Section 10: Order codes . Minor text changes.

Please Read Carefully:

Information in this document is provided solely in connection with ST products. STMicroelectronics NV and its subsidiaries ("ST") reserve the right to make changes, corrections, modifications or improvements, to this document, and the products and services described herein at any time, without notice.

All ST products are sold pursuant to ST's terms and conditions of sale.

Purchasers are solely responsible for the choice, selection and use of the ST products and services described herein, and ST assumes no liability whatsoever relating to the choice, selection or use of the ST products and services described herein.

No license, express or implied, by estoppel or otherwise, to any intellectual property rights is granted under this document. If any part of this document refers to any third party products or services it shall not be deemed a license grant by ST for the use of such third party products or services, or any intellectual property contained therein or considered as a warranty covering the use in any manner whatsoever of such third party products or services or any intellectual property contained therein.

UNLESS OTHERWISE SET FORTH IN ST'S TERMS AND CONDITIONS OF SALE ST DISCLAIMS ANY EXPRESS OR IMPLIED WARRANTY WITH RESPECT TO THE USE AND/OR SALE OF ST PRODUCTS INCLUDING WITHOUT LIMITATION IMPLIED WARRANTIES OF MERCHANTABILITY, FITNESS FOR A PARTICULAR PURPOSE (AND THEIR EQUIVALENTS UNDER THE LAWS OF ANY JURISDICTION), OR INFRINGEMENT OF ANY PATENT, COPYRIGHT OR OTHER INTELLECTUAL PROPERTY RIGHT.

ST PRODUCTS ARE NOT DESIGNED OR AUTHORIZED FOR USE IN: (A) SAFETY CRITICAL APPLICATIONS SUCH AS LIFE SUPPORTING, ACTIVE IMPLANTED DEVICES OR SYSTEMS WITH PRODUCT FUNCTIONAL SAFETY REQUIREMENTS; (B) AERONAUTIC APPLICATIONS; (C) AUTOMOTIVE APPLICATIONS OR ENVIRONMENTS, AND/OR (D) AEROSPACE APPLICATIONS OR ENVIRONMENTS. WHERE ST PRODUCTS ARE NOT DESIGNED FOR SUCH USE, THE PURCHASER SHALL USE PRODUCTS AT PURCHASER'S SOLE RISK, EVEN IF ST HAS BEEN INFORMED IN WRITING OF SUCH USAGE, UNLESS A PRODUCT IS EXPRESSLY DESIGNATED BY ST AS BEING INTENDED FOR "AUTOMOTIVE, AUTOMOTIVE SAFETY OR MEDICAL" INDUSTRY DOMAINS ACCORDING TO ST PRODUCT DESIGN SPECIFICATIONS. PRODUCTS FORMALLY ESCC, QML OR JAN QUALIFIED ARE DEEMED SUITABLE FOR USE IN AEROSPACE BY THE CORRESPONDING GOVERNMENTAL AGENCY.

Resale of ST products with provisions different from the statements and/or technical features set forth in this document shall immediately void any warranty granted by ST for the ST product or service described herein and shall not create or extend in any manner whatsoever, any liability of ST.

ST and the ST logo are trademarks or registered trademarks of ST in various countries.

Information in this document supersedes and replaces all information previously supplied.

The ST logo is a registered trademark of STMicroelectronics. All other names are the property of their respective owners.

© 2013 STMicroelectronics - All rights reserved

STMicroelectronics group of companies

Australia - Belgium - Brazil - Canada - China - Czech Republic - Finland - France - Germany - Hong Kong - India - Israel - Italy - Japan - Malaysia - Malta - Morocco - Philippines - Singapore - Spain - Sweden - Switzerland - United Kingdom - United States of America

www.st.com