

N-Channel Logic Level Enhancement Mode MOSFET

MTN139ZN3

Description

The MTN139ZN3 is a N-channel enhancement-mode MOSFET.

Features

- Low on-resistance
- High ESD
- High speed switching
- Low-voltage drive
- Easily designed drive circuits
- Easy to use in parallel
- Pb-free package

Symbol

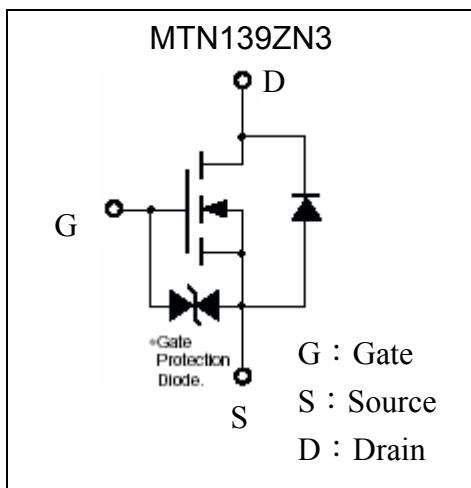

Outline

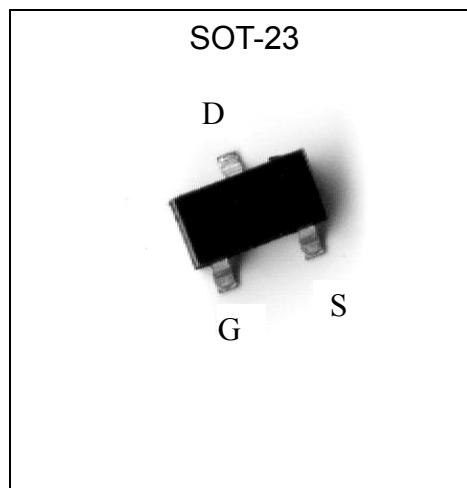



Absolute Maximum Ratings (Ta=25°C)

Table with 4 columns: Parameter, Symbol, Limits, Unit. Rows include Drain-Source Voltage, Gate-Source Voltage, Drain Current (Continuous/Pulsed), Drain Reverse Current (Continuous/Pulsed), Total Power Dissipation, ESD susceptibility, Channel Temperature, and Storage Temperature.

Thermal Characteristics

Table with 4 columns: Parameter, Symbol, Value, Unit. Row: Thermal Resistance, Junction to Ambient (RθJA) with value 357 °C/W.

- Note : *1. Pulse Width ≤ 300μs, Duty cycle ≤ 2%
*2. When the device is mounted on a glass epoxy board with area measuring 1x0.75x0.62 inch
*3. Human body model, 1.5kΩ in series with 100pF

Electrical Characteristics (Ta=25°C)

Table with 6 columns: Symbol, Min., Typ., Max., Unit, Test Conditions. Rows include BV_DSS, V_GS(th), I_GSS, I_DSS, R_DS(on)*, G_FS, C_iss, C_oss, and C_rss.

*Pulse Test : Pulse Width ≤ 300μs, Duty Cycle ≤ 2%

Ordering Information

Table with 4 columns: Device, Package, Shipping, Marking. Row: MTN139ZN3, SOT-23 (Pb-free), 3000 pcs / Tape & Reel, 702

Characteristic Curves

Typical Output Characteristics

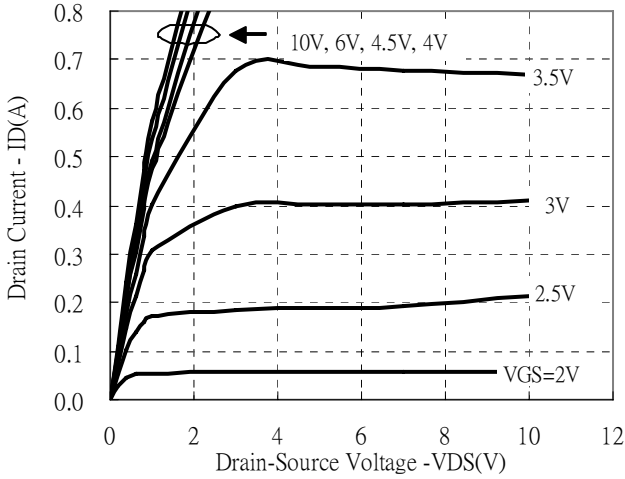

Typical Transfer Characteristics

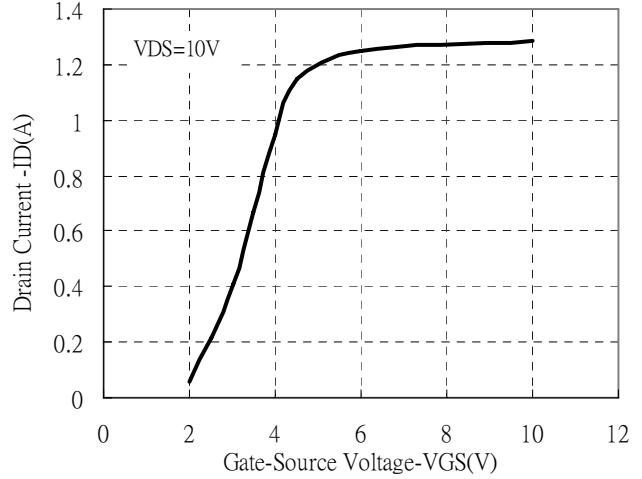

Static Drain-Source On-State resistance vs Drain Current

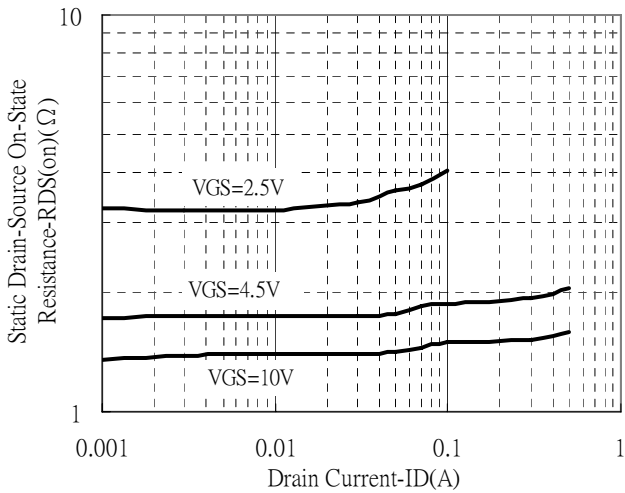

Reverse Drain Current vs Source-Drain Voltage

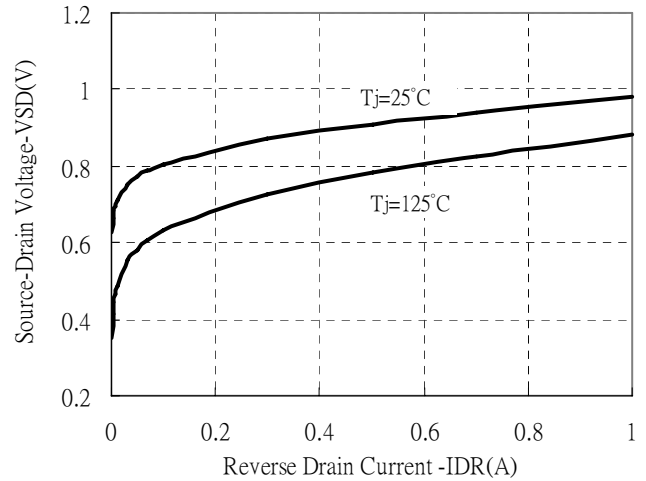

Static Drain-Source On-State Resistance vs Gate-Source Voltage

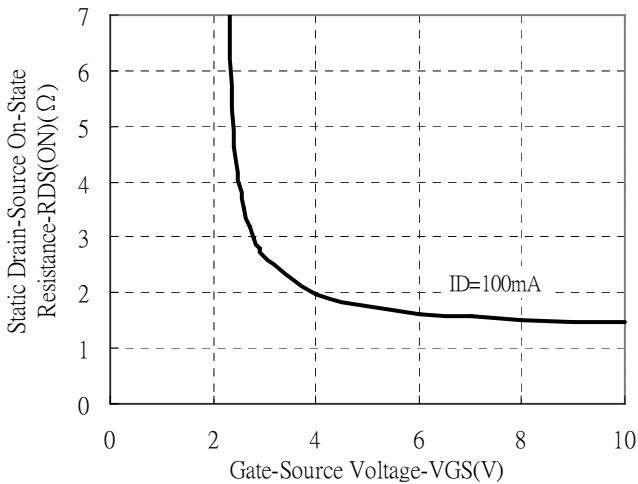

Drain-Source On-State Resistance vs Junction Temperature

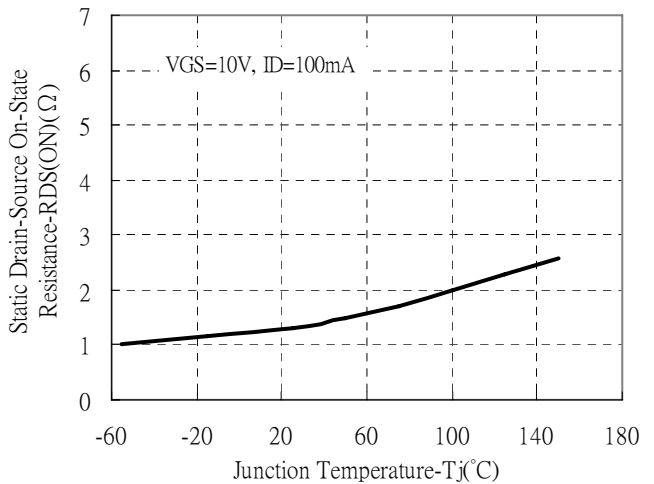



Characteristic Curves(Cont.)

Capacitance vs Drain-to-Source Voltage

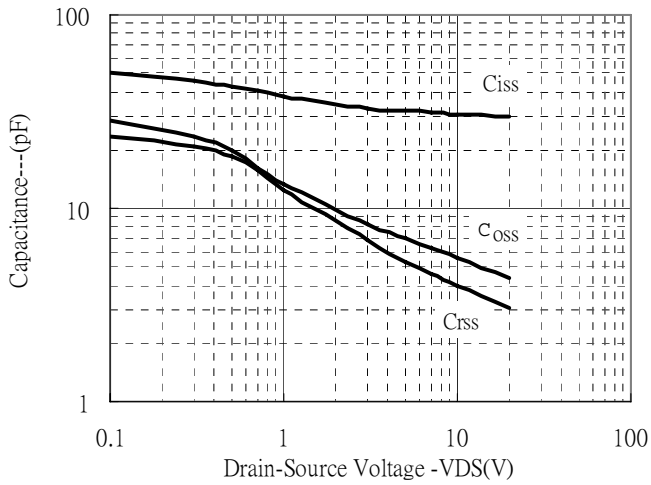

Threshold Voltage vs Junction Temperature

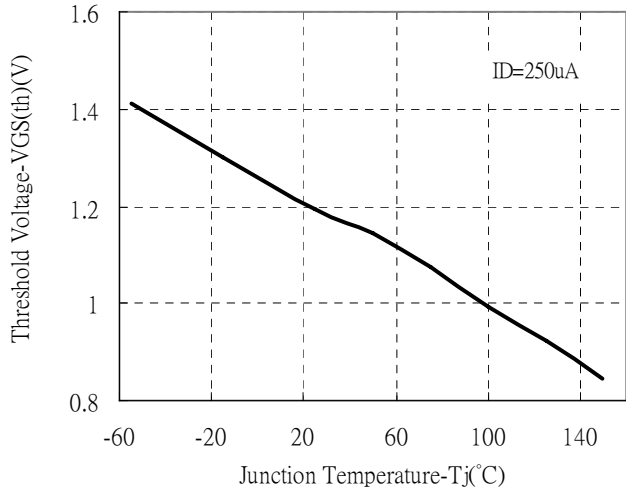

Power Derating Curve

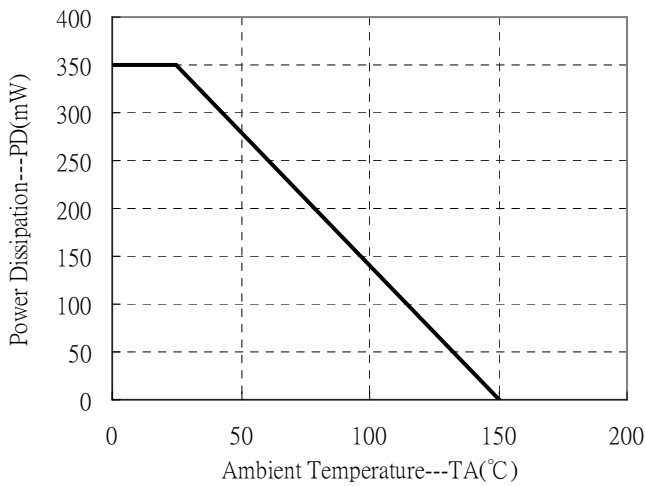

Reel Dimension

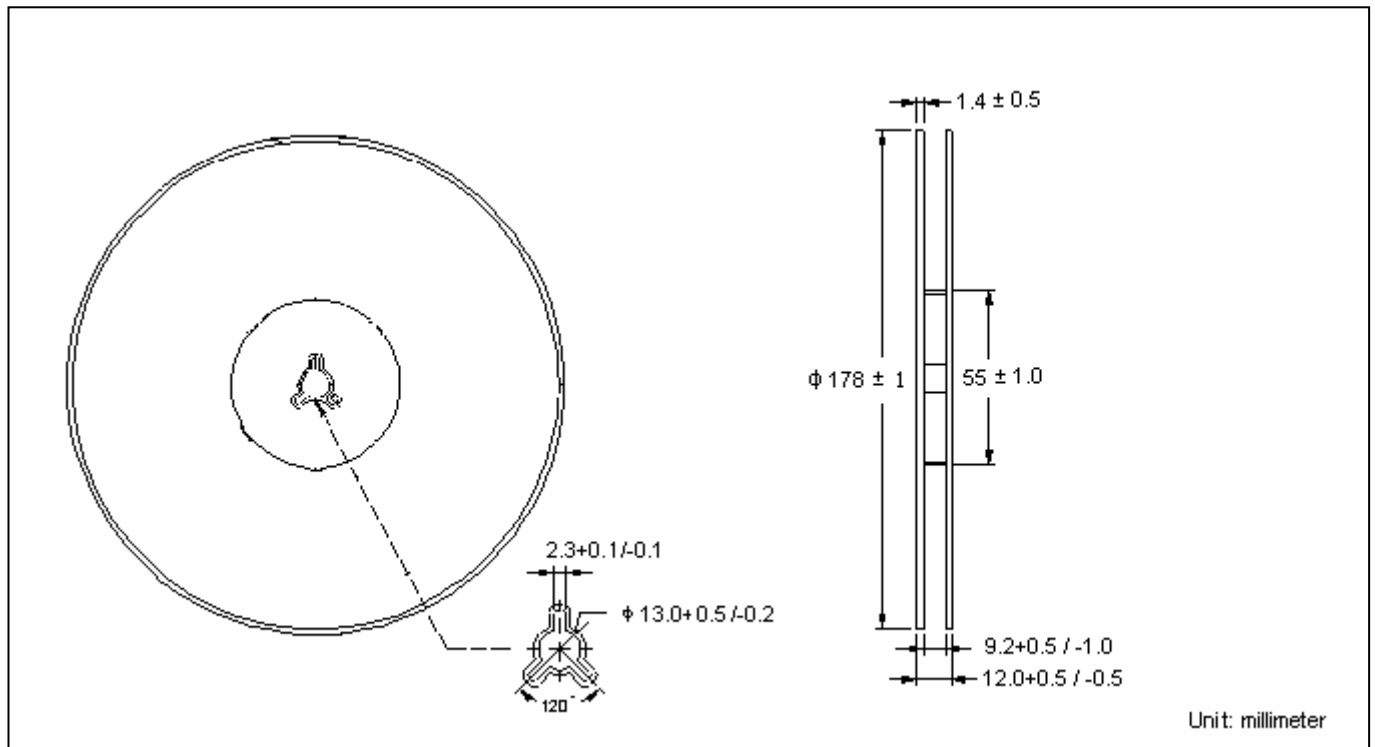

Carrier Tape Dimension

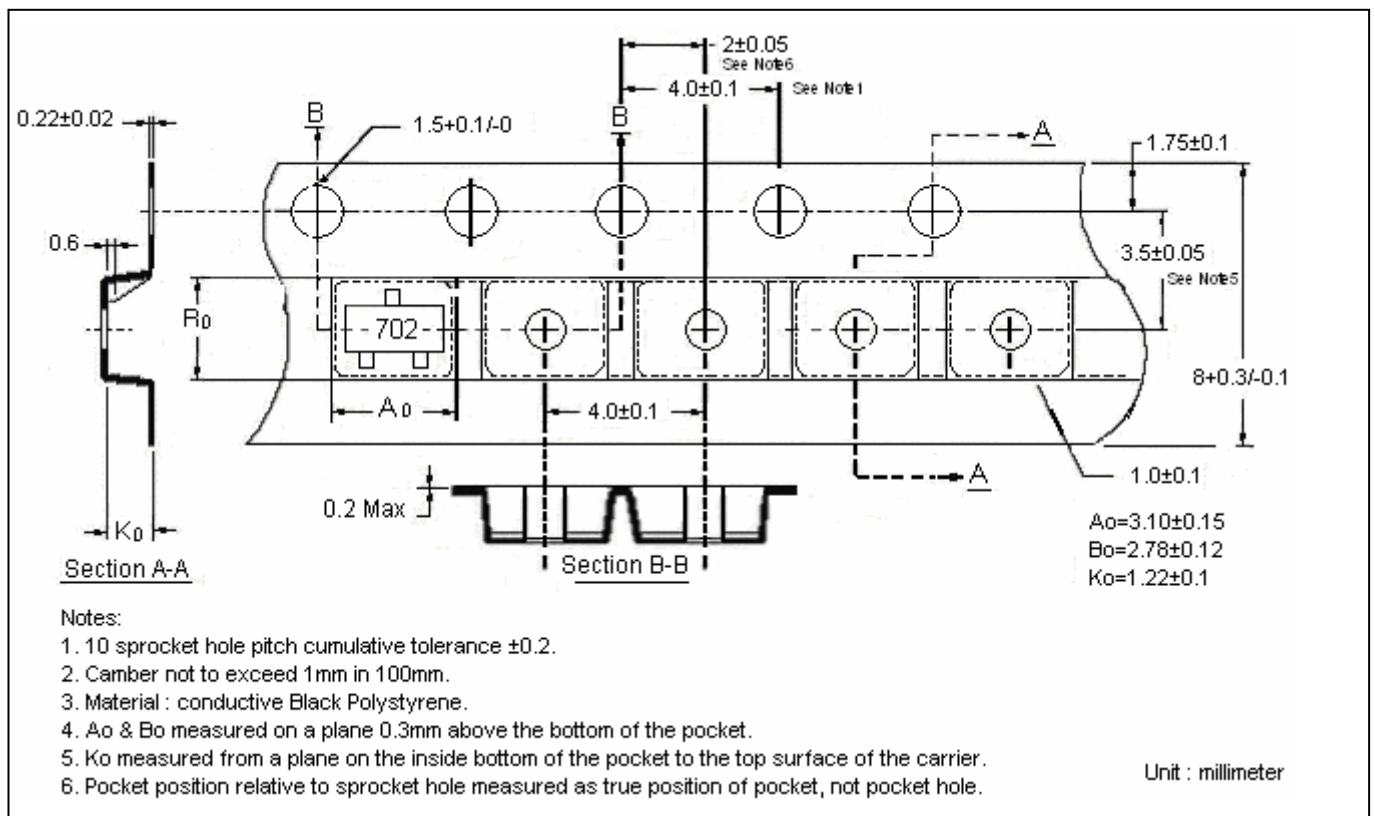

Recommended wave soldering condition

Product	Peak Temperature	Soldering Time
Pb-free devices	260 +0/-5 °C	5 +1/-1 seconds

Recommended temperature profile for IR reflow



Profile feature	Sn-Pb eutectic Assembly	Pb-free Assembly
Average ramp-up rate (Tsmax to Tp)	3°C/second max.	3°C/second max.
Preheat		
-Temperature Min(Ts min)	100°C	150°C
-Temperature Max(Ts max)	150°C	200°C
-Time(ts min to ts max)	60-120 seconds	60-180 seconds
Time maintained above:		
-Temperature (T _L)	183°C	217°C
- Time (t _L)	60-150 seconds	60-150 seconds
Peak Temperature(T _P)	240 +0/-5 °C	260 +0/-5 °C
Time within 5°C of actual peak temperature(tp)	10-30 seconds	20-40 seconds
Ramp down rate	6°C/second max.	6°C/second max.
Time 25 °C to peak temperature	6 minutes max.	8 minutes max.

Note : All temperatures refer to topside of the package, measured on the package body surface.

SOT-23 Dimension

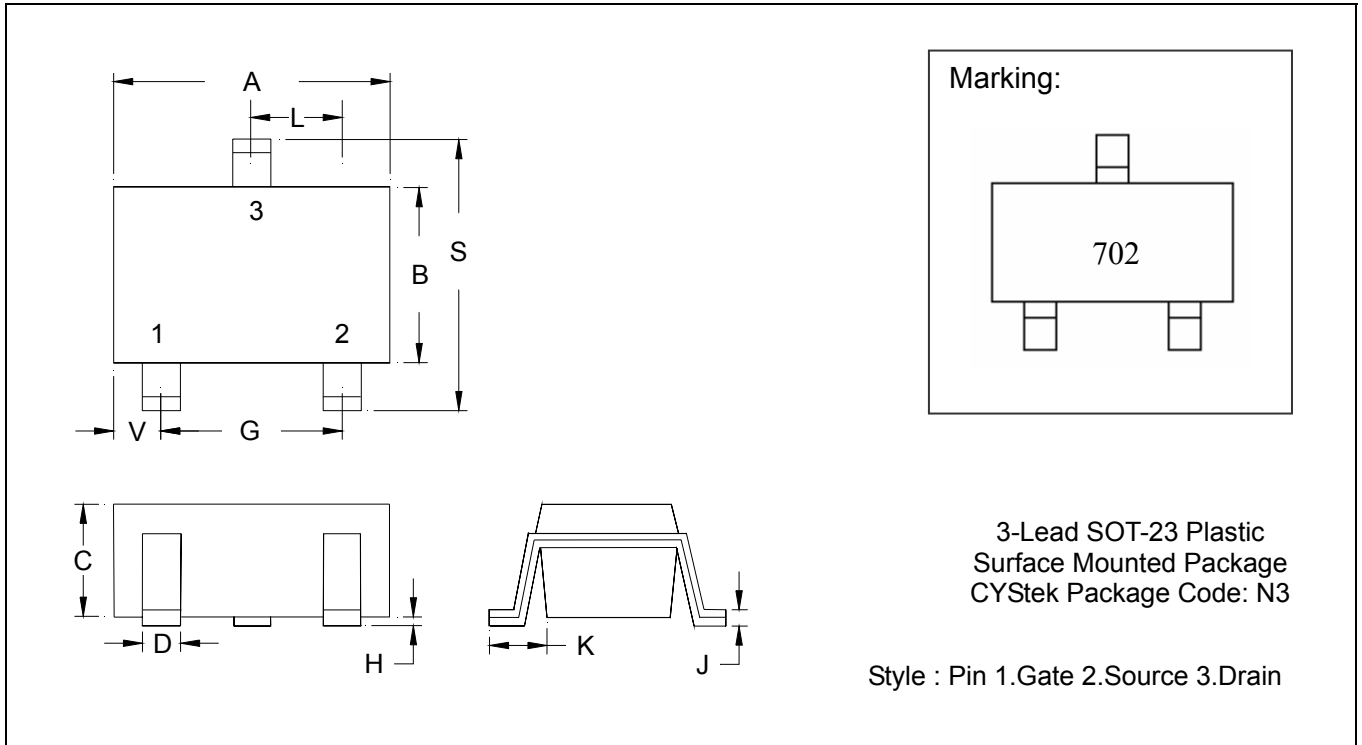

*:Typical

DIM	Inches		Millimeters		DIM	Inches		Millimeters	
	Min.	Max.	Min.	Max.		Min.	Max.	Min.	Max.
A	0.1102	0.1204	2.80	3.04	J	0.0034	0.0070	0.09	0.18
B	0.0472	0.0630	1.20	1.60	K	0.0128	0.0266	0.32	0.67
C	0.0335	0.0512	0.89	1.30	L	0.0335	0.0453	0.85	1.15
D	0.0118	0.0197	0.30	0.50	S	0.0830	0.1161	2.10	2.95
G	0.0669	0.0910	1.70	2.30	V	0.0098	0.0256	0.25	0.65
H	0.0005	0.0040	0.013	0.10					

Notes : 1.Controlling dimension : millimeters.
 2.Maximum lead thickness includes lead finish thickness, and minimum lead thickness is the minimum thickness of base material.
 3.If there is any question with packing specification or packing method, please contact your local CYStek sales office.

Material :

- Lead : Pure tin plated.
- Mold Compound : Epoxy resin family, flammability solid burning class:UL94V-0.

Important Notice:

- All rights are reserved. Reproduction in whole or in part is prohibited without the prior written approval of CYStek.
- CYStek reserves the right to make changes to its products without notice.
- CYStek **semiconductor products are not warranted to be suitable for use in Life-Support Applications, or systems.**
- CYStek assumes no liability for any consequence of customer product design, infringement of patents, or application assistance.