



Zero Delay Buffers

General Description

The ICS9179-06 generates low skew clock buffers required for high speed RISC or CISC microprocessor systems such as Intel PentiumPro. An output enable is provided for testability.

The device is a buffer with low output to output skew. This is a zero delay buffer device, using an internal PLL. This buffer can be used for phase synchronization to a master clock. With the wide PLL loop BW, this buffer is compatible to Spread Spectrum input clocks from clock generator products such as the ICS9148-27.

The individual clock outputs are addressable through I²C to be enabled, or stopped in a low state for reduced EMI when the lines are not needed. The device defaults to zero-delay mode, but can be programmed with I²C for selectable delays -2.7, +2.0, -0.7 ns (nominal target values).

Features

- Zero delay buffer, 16 outputs
- Supports up to four SDRAM DIMMS
- Wide PLL loop bandwidth makes this part ideal in Spread Spectrum applications.
- Skew Input to FB_IN ± 250 ps default, with selectable skew -2.7, +2.0, -0.7ns nominal.
- Synchronous clocks skew matched to 250 ps window on output.
- 33 to 133MHz input or output frequency.
- I²C Serial Configuration interface to allow individual clocks to be stopped, or selectable delays.
- Multiple VDD, VSS pins for noise reduction
- Slew rate 1.5V/ns into 30pF.
- VDD = 3.3 \pm 5%, 0 to 70°C
- All outputs (0:15) tristate with OE low (FB_OUT stays running).
- 48-Pin SSOP package

Block Diagram

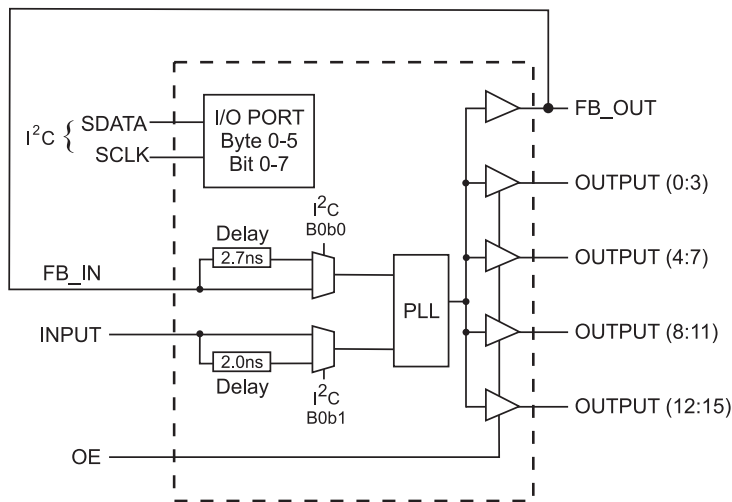

Pin Configuration

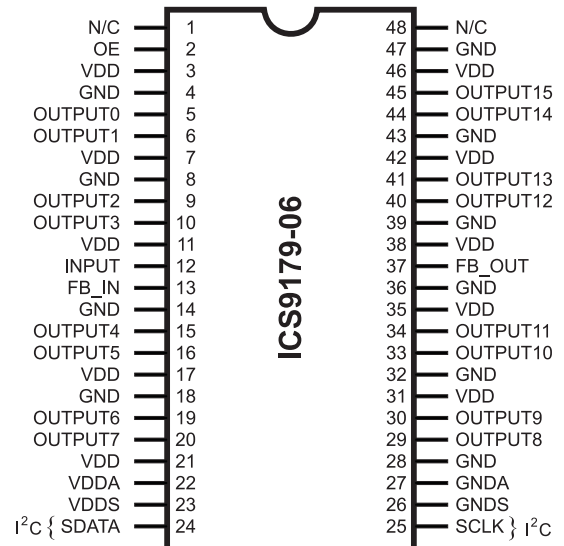

48-Pin SSOP

Functionality

OE#	OUTPUT (0:15)	FB_OUT
0	Hi-Z	1 X INPUT
1	1 X INPUT	1 X INPUT

PentiumPro is a trademark of Intel Corporation
I²C is a trademark of Philips Corporation



Pin Descriptions

PIN NUMBER	PIN NAME	TYPE	DESCRIPTION
2	OE	IN	Tri-states all outputs except FB_OUT when held LOW. Has internal pull-up. ²
5, 6, 9, 10	OUTPUT (0:3)	OUT	SDRAM Byte 0 clock outputs ¹
15, 16, 19, 20	OUTPUT (4:7)	OUT	SDRAM Byte 1 clock outputs ¹
29, 30, 33, 34	OUTPUT (8:11)	OUT	SDRAM Byte 2 clock outputs ¹
40, 41, 44, 45	OUTPUT (12:15)	OUT	SDRAM Byte 3 clock outputs ¹
12	INPUT	IN	Input for reference clock.
13	FB_IN	IN	Feedback input.
24	SDATA	I/O	Data pin for I ² C circuitry ³
25	SCLK	I/O	Clock pin for I ² C circuitry ³
37	FB_OUT	OUT	Feedback output to input FB_IN.
3, 7, 11, 17, 21, 31, 35, 38, 42, 46	VDD	PWR	3.3V Power supply for output buffers
4, 8, 14, 18, 28, 32, 36, 39, 43, 47	GND	PWR	Ground for output buffers
22	VDDA	PWR	3.3V Power supply for Analog PLL stages
23	VDDS	PWR	3.3V Power supply for I ² C circuitry
26	GNDS	PWR	Ground for I ² C circuitry
27	GNDA	PWR	Ground for Analog PLL stages
1, 48	N/C	-	Pins are not internally connected

Notes:

- At power up all sixteen outputs are enabled and active.
- OE has a 100K Ohm internal pull-up resistor to keep all outputs active.
- The SDATA and SCLK inputs both also have internal pull-up resistors with values above 100K Ohms as well for complete platform flexibility.
- I²C Byte0, bits 0 & 1 used to select delay. Default* values at power up is 0
- Subject to design engineering verification of target value.

Delay Selection Table⁴

Power Groups

VDD = Power supply for OUTPUT buffers
 VDDS = Power supply for I²C circuitry
 VDDA = Power supply for Analog PLL circuitry

Ground Groups

GND = Ground supply for OUTPUT buffer
 GNDS = Ground supply for I²C circuitry
 GNDA = Ground supply for Analog PLL circuitry

INPUT Control Byte0 bit1	FB_IN Control Byte0 bit0	Nominal Target ⁵ Delay, INPUT to FB_IN pins.
0*	0*	0ns
0	1	-2.7ns
1	0	+2.0ns
1	1	-0.7ns



General I²C serial interface information

The information in this section assumes familiarity with I²C programming.
For more information, contact ICS for an I²C programming application note.

How to Write:

- Controller (host) sends a start bit.
- Controller (host) sends the write address D2_(H)
- ICS clock will **acknowledge**
- Controller (host) sends a dummy command code
- ICS clock will **acknowledge**
- Controller (host) sends a dummy byte count
- ICS clock will **acknowledge**
- Controller (host) starts sending first byte (Byte 0) through byte 5
- ICS clock will **acknowledge** each byte **one at a time**.
- Controller (host) sends a Stop bit

How to Write:	
Controller (Host)	ICS (Slave/Receiver)
Start Bit	
Address D2 _(H)	
	ACK
Dummy Command Code	
	ACK
Dummy Byte Count	
	ACK
Byte 0	
	ACK
Byte 1	
	ACK
Byte 2	
	ACK
Byte 3	
	ACK
Byte 4	
	ACK
Byte 5	
	ACK
Stop Bit	

How to Read:

- Controller (host) will send start bit.
- Controller (host) sends the read address D3_(H)
- ICS clock will **acknowledge**
- ICS clock will send the **byte count**
- Controller (host) acknowledges
- ICS clock sends first byte (**Byte 0**) through **byte 5**
- Controller (host) will need to acknowledge each byte
- Controller (host) will send a stop bit

How to Read:	
Controller (Host)	ICS (Slave/Receiver)
Start Bit	
Address D3 _(H)	
	ACK
	Byte Count
ACK	
	Byte 0
ACK	
	Byte 1
ACK	
	Byte 2
ACK	
	Byte 3
ACK	
	Byte 4
ACK	
	Byte 5
ACK	
Stop Bit	

Notes:

1. The ICS clock generator is a slave/receiver, I²C component. It can read back the data stored in the latches for verification. **Read-Back will support Intel PIIX4 "Block-Read" protocol.**
2. The data transfer rate supported by this clock generator is 100K bits/sec or less (standard mode)
3. The input is operating at 3.3V logic levels.
4. The data byte format is 8 bit bytes.
5. To simplify the clock generator I²C interface, the protocol is set to use only "**Block-Writes**" from the controller. The bytes must be accessed in sequential order from lowest to highest byte with the ability to stop after any complete byte has been transferred. The Command code and Byte count shown above must be sent, but the data is ignored for those two bytes. The data is loaded until a Stop sequence is issued.
6. At power-on, all registers are set to a default condition, as shown.



ICS9179-06 Power Management

The values below are estimates of target specifications.

Condition	Max 3.3V supply consumption Max discrete cap loads VDD = 3.465V All static inputs = VDD or GND
No Clock Mode (BUF_IN - VDD1 or GND) I ² C Circuitry Active	30mA
Active 66MHz (BUF_IN = 66.66MHz)	150mA
Active 100MHz (BUF_IN = 100.00MHz)	180mA

Byte 2: OUTPUT Clock Register (Default = 1)

BIT	PIN#	PWD	DESCRIPTION
Bit 7	45	1	OUTPUT 15 (Act/Inact)
Bit 6	44	1	OUTPUT 14 (Act/Inact)
Bit 5	41	1	OUTPUT 13 (Act/Inact)
Bit 4	40	1	OUTPUT 12 (Act/Inact)
Bit 3	34	1	OUTPUT 11 (Act/Inact)
Bit 2	33	1	OUTPUT 10 (Act/Inact)
Bit 1	30	1	OUTPUT 9 (Active/Inactive)
Bit 0	29	1	OUTPUT 8 (Active/Inactive)

Notes: 1 = Enabled; 0 = Disabled, outputs held low

Note: PWD = Power-Up Default

Byte 3: OUTPUT Clock Register

BIT	PIN#	PWD	DESCRIPTION
Bit 7	-	1	Reserved
Bit 6	-	1	Reserved
Bit 5	-	1	Reserved
Bit 4	-	1	Reserved
Bit 3	-	1	Reserved
Bit 2	-	1	Reserved
Bit 1	-	1	Reserved
Bit 0	-	1	Reserved

Notes: 1 = Enabled; 0 = Disabled, outputs held low

Serial Configuration Command Bitmaps

Byte 0: OUTPUT Clock Register (default = 0)

BIT	PIN#	PWD	DESCRIPTION
Bit 7	-	0	Reserved
Bit 6	-	0	Reserved
Bit 5	-	0	Reserved
Bit 4	-	0	Reserved
Bit 3	-	0	Reserved
Bit 2	-	0	Reserved
Bit 1 ²	12	0	Clock INPUT Skew Control
Bit 0 ²	13	0	FBIN Skew Control

Notes: 2 = Default = 0; 1 = Delay element enabled,
0 = No delay path.

Byte 1: OUTPUT Clock Register

BIT	PIN#	PWD	DESCRIPTION
Bit7	20	1	OUTPUT 7 (Act/Inact)
Bit6	19	1	OUTPUT 6 (Act/Inact)
Bit5	16	1	OUTPUT 5 (Act/Inact)
Bit4	15	1	OUTPUT 4 (Act/Inact)
Bit3	10	1	OUTPUT 3 (Act/Inact)
Bit2	9	1	OUTPUT 2 (Act/Inact)
Bit1	6	1	OUTPUT 1 (Act/Inact)
Bit0	5	1	OUTPUT 0 (Act/Inact)

Notes: 1 = Enabled; 0 = Disabled, outputs held low

Note: PWD = Power-Up Default



Absolute Maximum Ratings

Supply Voltage 7.0 V
 Logic Inputs GND -0.5 V to V_{DD} +0.5 V
 Ambient Operating Temperature 0°C to +70°C
 Storage Temperature -65°C to +150°C

Stresses above those listed under *Absolute Maximum Ratings* may cause permanent damage to the device. These ratings are stress specifications only and functional operation of the device at these or any other conditions above those listed in the operational sections of the specifications is not implied. Exposure to absolute maximum rating conditions for extended periods may affect product reliability.

Electrical Characteristics - Input & Supply

T_A = 0 - 70°C; Supply Voltage V_{DD} = 3.3 V +/-5% (unless otherwise stated)

PARAMETER	SYMBOL	CONDITIONS	MIN	TYP	MAX	UNITS
Input High Voltage	V _{IH}		2		V _{DD} +0.3	V
Input Low Voltage	V _{IL}		V _{SS} -0.3		0.8	V
Input High Current	I _{IH}	V _{IN} = V _{DD}			5	uA
Input Low Current	I _{IL1}	V _{IN} = 0 V; Inputs with no pull-up resistors	-5			uA
Input Low Current	I _{IL2}	V _{IN} = 0 V; Inputs with pull-up resistors	-60	-33		uA
Operating Supply Current	I _{DD}	C _L = 0 pF; F _{IN} @ 66M		115	150	mA
		C _L = 0 pF; F _{IN} @ 100M		170	180	mA
Output Disabled Supply Current	I _{DD}	C _L = 0 pF; F _{IN} @ 66M			30	mA
		C _L = 0 pF; F _{IN} @ 100M			30	mA
Input frequency	F _i	V _{DD} = 3.3 V; All Outputs Loaded	33		105	MHz
Input Capacitance	C _{IN}	Logic Inputs			5	pF

¹Guaranteed by design, not 100% tested in production.

Electrical Characteristics - Input & Supply

T_A = 0 - 70°C; Supply Voltage V_{DD} = 3.3 V +/-5% (unless otherwise stated)

PARAMETER	SYMBOL	CONDITIONS	MIN	TYP	MAX	UNITS
Input High Voltage	V _{IH}		2		V _{DD} +0.3	V
Input Low Voltage	V _{IL}		V _{SS} -0.3		0.8	V
Input High Current	I _{IH}	V _{IN} = V _{DD}			5	uA
Input Low Current	I _{IL}	V _{IN} = 0 V; Inputs with no pull-up resistors	-5			uA
		V _{IN} = 0 V; Inputs with 100K pull-up resistors	-60	-33		uA
Operating Supply Current	I _{DD1}	C _L = 0 pF; F _{IN} @ 66M		115	150	mA
		C _L = 0 pF; F _{IN} @ 100M		170	180	mA
Input frequency	F _i ¹	V _{DD} = 3.3 V; All Outputs Loaded	10		150	MHz
Input Capacitance	C _{IN} ¹	Logic Inputs			5	pF

¹Guaranteed by design, not 100% tested in production.



Electrical Characteristics - SDRAM

$T_A = 0 - 70^\circ\text{C}$; $V_{DD} = V_{DDL} = 3.3 \text{ V} \pm 5\%$; $C_L = 20 - 30 \text{ pF}$ (unless otherwise stated)

PARAMETER	SYMBOL	CONDITIONS	MIN	TYP	MAX	UNITS
Output Frequency	F_{O3}		33		133	MHz
Output Impedance	R_{DSP3}	$V_O = V_{DD} * (0.5)$	10		24	Ohm
Output Impedance	R_{DSN3}	$V_O = V_{DD} * (0.5)$	10		24	Ohm
Output High Voltage	V_{OH3}	$I_{OH} = -30 \text{ mA}$	2.6			V
Output Low Voltage	V_{OL3}	$I_{OL} = 23 \text{ mA}$			0.4	V
Output High Current	I_{OH3}	$V_{OH} = 2.0 \text{ V}$			-54	mA
Output Low Current	I_{OL3}	$V_{OL} = 0.8 \text{ V}$	40			mA
Rise Time	T_{r3}	$V_{OL} = 0.4 \text{ V}, V_{OH} = 2.4 \text{ V}$			1.33	nS
Fall Time	T_{f3}	$V_{OH} = 2.4 \text{ V}, V_{OL} = 0.4 \text{ V}$			1.33	nS
Duty Cycle	D_{t3}	$V_T = 1.5 \text{ V}$	45		55	%
Output to Output Skew Window	T_{sk3}	$V_T = 1.5 \text{ V}$			250	pS
IN to FB_IN Skew ^{1,2}	T_{skd1}	$V_T = 1.5 \text{ V}$ default Zero delay I ² C B0 bits 0, 1 = 00	-250	0	250	pS
	T_{skd2}	$V_T = 1.5 \text{ V}$ bits 0, 1 = 10	-2.2	-2.7	-3.2	nS
	T_{skd3}	$V_T = 1.5 \text{ V}$ bits 0, 1 = 01	+1.5	+2.0	+2.5	nS
	T_{skd4}	$V_T = 1.5 \text{ V}$ bits 0, 1 = 11	-0.2	-0.7	-1.2	nS

Notes:

- Guaranteed by design, not 100% tested in production
- Delay elements FBIN and clock INPUT path are selected by I²C BYTE2; bit 0 = clock input control, bit 1 = Clock INPUT Control. (Default is 0). A 0 = No delay in path, 1 = Delay element selected.

Note: PWD = Power-Up Default

Input Pulse

			MIN	TYP	MAX	UNITS
Input Pulse Low Time	T_{im-Low}	$V_{pulse_Low} \leq 0.8\text{V}$	1.0			ns
Input Pulse High Time	$T_{im-High}$	$V_{pulse_High} \geq 2.0\text{V}$	1.5			ns



General Layout Precautions:

- 1) Use a ground plane on the top layer of the PCB in all areas not used by traces.
- 2) Make all power traces and vias as wide as possible to lower inductance.

Notes:

- 1 All clock outputs should have series terminating resistor. Not shown in all places to improve readability of diagram
- 2 Optional EMI capacitor should be used on all CPU, SDRAM, and PCI outputs.

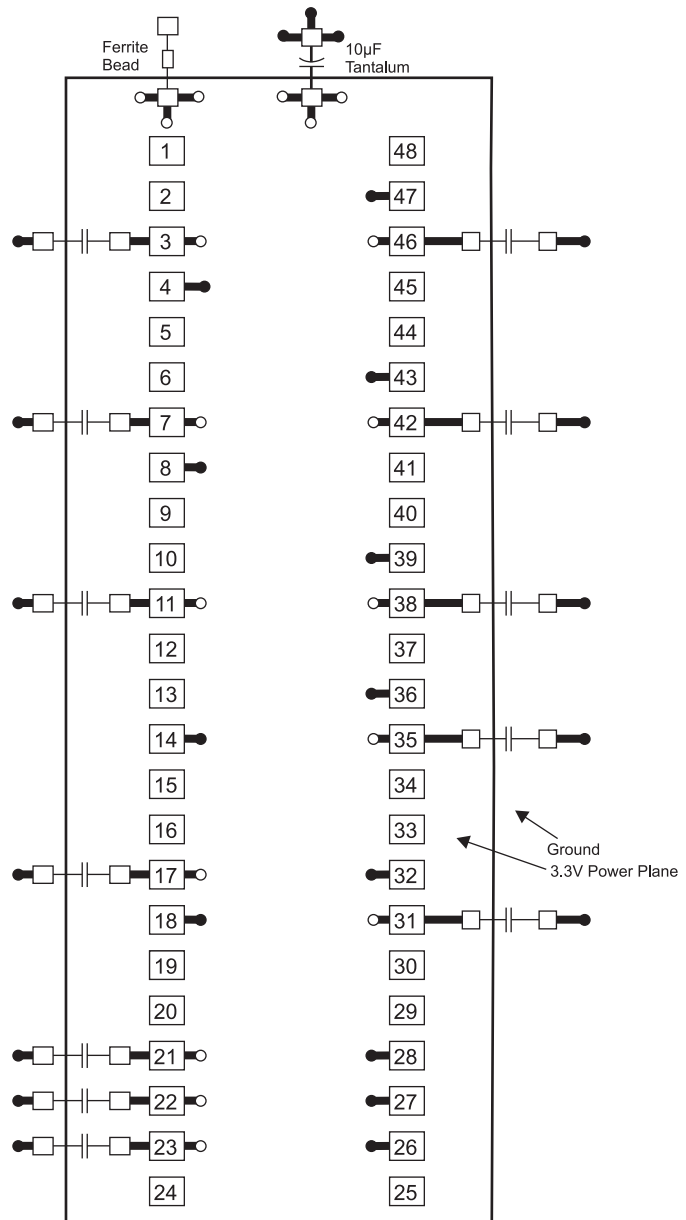

Capacitor Values:

All unmarked capacitors are 0.01µF ceramic

- = Ground Plane Connection
- = Power Plane Connection
- = Solder Pads

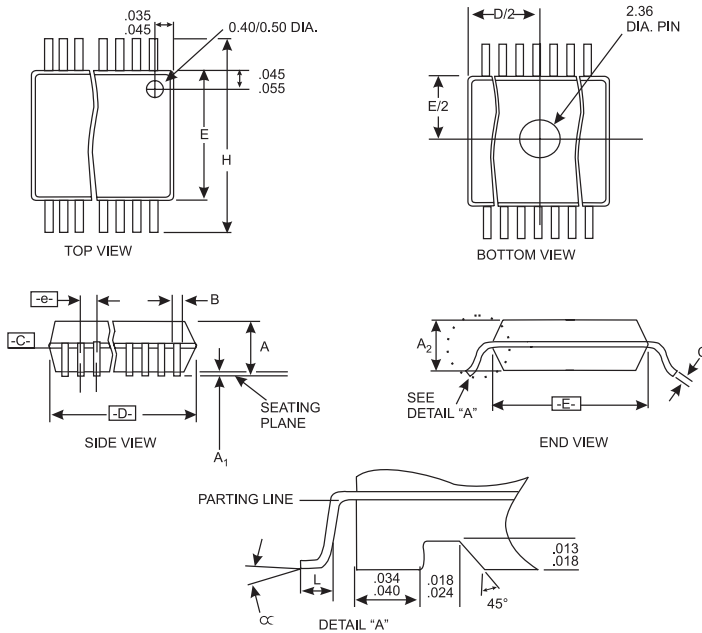

SSOP Package

SYMBOL	COMMON DIMENSIONS			VARIATIONS	D			N
	MIN.	NOM.	MAX.		MIN.	NOM.	MAX.	
A	.095	.101	.110	AC	.620	.625	.630	48
A1	.008	.012	.016					
A2	.088	.090	.092					
B	.008	.010	.0135					
C	.005	-	.010					
D	See Variations							
E	.292	.296	.299					
e	0.025 BSC							
H	.400	.406	.410					
h	.010	.013	.016					
L	.024	.032	.040					
N	See Variations							
∞	0°	5°	8°					
X	.085	.093	.100					

Ordering Information

ICS9179F-06

Example:

ICS XXXX F - PPP

