



# LPC11D14

32-bit ARM Cortex-M0 microcontroller; 32 kB flash and 8 kB SRAM; 40 segment x 4 LCD driver

Rev. 2 — 23 July 2012

Product data sheet

## 1. General description

---

The LPC11D14 is a ARM Cortex-M0 based, low-cost 32-bit MCU family, designed for 8/16-bit microcontroller applications, offering performance, low power, simple instruction set and memory addressing together with reduced code size compared to existing 8/16-bit architectures.

The LPC11D14 is a dual-chip module consisting of a LPC1114 single-chip microcontroller combined with a PCF8576D Universal LCD driver in a low-cost 100-pin package. The LCD driver provides 40 segments and supports from one to four backplanes. Display overhead is minimized by an on-chip display RAM with auto-increment addressing.

The LPC11D14 operates at CPU frequencies of up to 50 MHz.

The peripheral complement of the LPC11D14 includes 32 kB of flash memory, 8 kB of data memory, one Fast-mode Plus I<sup>2</sup>C-bus interface, one RS-485/EIA-485 UART, up to two SPI interfaces with SSP features, four general purpose counter/timers, a 10-bit ADC, and up to 42 general purpose I/O pins.

**Remark:** For a functional description of the LPC1114 microcontroller see the LPC1111/12/13/14 data sheet. For a detailed description of the LCD driver see the PCF8576D data sheet. Both data sheets are available on the NXP web site.

## 2. Features and benefits

---

- LCD driver
  - ◆ 40 segments.
  - ◆ One to four backplanes.
  - ◆ On-chip display RAM with auto-increment addressing.
- System:
  - ◆ ARM Cortex-M0 processor, running at frequencies of up to 50 MHz.
  - ◆ ARM Cortex-M0 built-in Nested Vectored Interrupt Controller (NVIC).
  - ◆ Serial Wire Debug.
  - ◆ System tick timer.
- Memory:
  - ◆ 32 kB on-chip flash programming memory.
  - ◆ 8 kB SRAM.
  - ◆ In-System Programming (ISP) and In-Application Programming (IAP) via on-chip bootloader software.



- Digital peripherals:
  - ◆ 42 General Purpose I/O (GPIO) pins with configurable pull-up/pull-down resistors. In addition, a configurable open-drain mode is supported.
  - ◆ GPIO pins can be used as edge and level sensitive interrupt sources.
  - ◆ High-current output driver (20 mA) on one pin.
  - ◆ High-current sink drivers (20 mA) on two I<sup>2</sup>C-bus pins in Fast-mode Plus.
  - ◆ Four general purpose counter/timers with a total of four capture inputs and 13 match outputs.
  - ◆ Programmable windowed WatchDog Timer (WDT).
- Analog peripherals:
  - ◆ 10-bit ADC with input multiplexing among 8 pins.
- Serial interfaces:
  - ◆ UART with fractional baud rate generation, internal FIFO, and RS-485 support.
  - ◆ Two SPI controllers with SSP features and with FIFO and multi-protocol capabilities.
  - ◆ I<sup>2</sup>C-bus interface supporting full I<sup>2</sup>C-bus specification and Fast-mode Plus with a data rate of 1 Mbit/s with multiple address recognition and monitor mode.
- Clock generation:
  - ◆ 12 MHz internal RC oscillator trimmed to 1 % accuracy that can optionally be used as a system clock.
  - ◆ Crystal oscillator with an operating range of 1 MHz to 25 MHz.
  - ◆ Programmable watchdog oscillator with a frequency range of 9.4 kHz to 2.3 MHz.
  - ◆ PLL allows CPU operation up to the maximum CPU rate without the need for a high-frequency crystal. May be run from the system oscillator or the internal RC oscillator.
  - ◆ Clock output function with divider that can reflect the system oscillator clock, IRC clock, CPU clock, and the Watchdog clock.
- Power control:
  - ◆ Integrated PMU (Power Management Unit) to minimize power consumption during Sleep, Deep-sleep, and Deep power-down modes.
  - ◆ Power profiles residing in boot ROM allowing to optimize performance and minimize power consumption for any given application through one simple function call.
  - ◆ Three reduced power modes: Sleep, Deep-sleep, and Deep power-down.
  - ◆ Processor wake-up from Deep-sleep mode via a dedicated start logic using up to 13 of the functional pins.
  - ◆ Power-On Reset (POR).
  - ◆ Brownout detect with four separate thresholds for interrupt and forced reset.
- Unique device serial number for identification.
- Single power supply (1.8 V to 3.6 V).
- Available as 100-pin LQFP100 package.

### 3. Applications

- Industrial applications (e.g. thermostats)
- White goods
- Human interface
- Sensors

### 4. Ordering information

Table 1. Ordering information

Type number	Package		Version
	Name	Description	
LPC11D14FBD100/302	LQFP100	plastic low profile quad flat package; 100 leads; body 14 × 14 × 1.4 mm	SOT407-1

#### 4.1 Ordering options

Table 2. Ordering options

Type number	Flash	Total SRAM	Power profiles	UART RS-485	I <sup>2</sup> C/ Fast+	SPI	ADC channels	Package
LPC11D14FBD100/302	32 kB	8 kB	yes	1	1	2	8	LQFP100

### 5. Block diagram

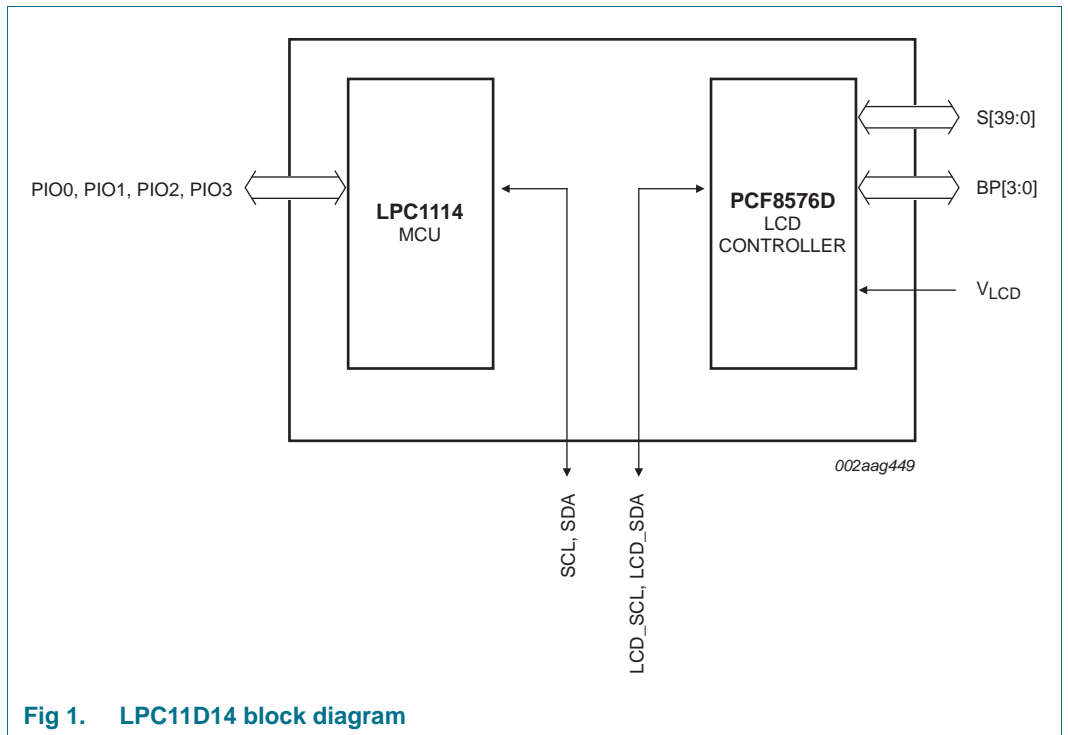

Fig 1. LPC11D14 block diagram

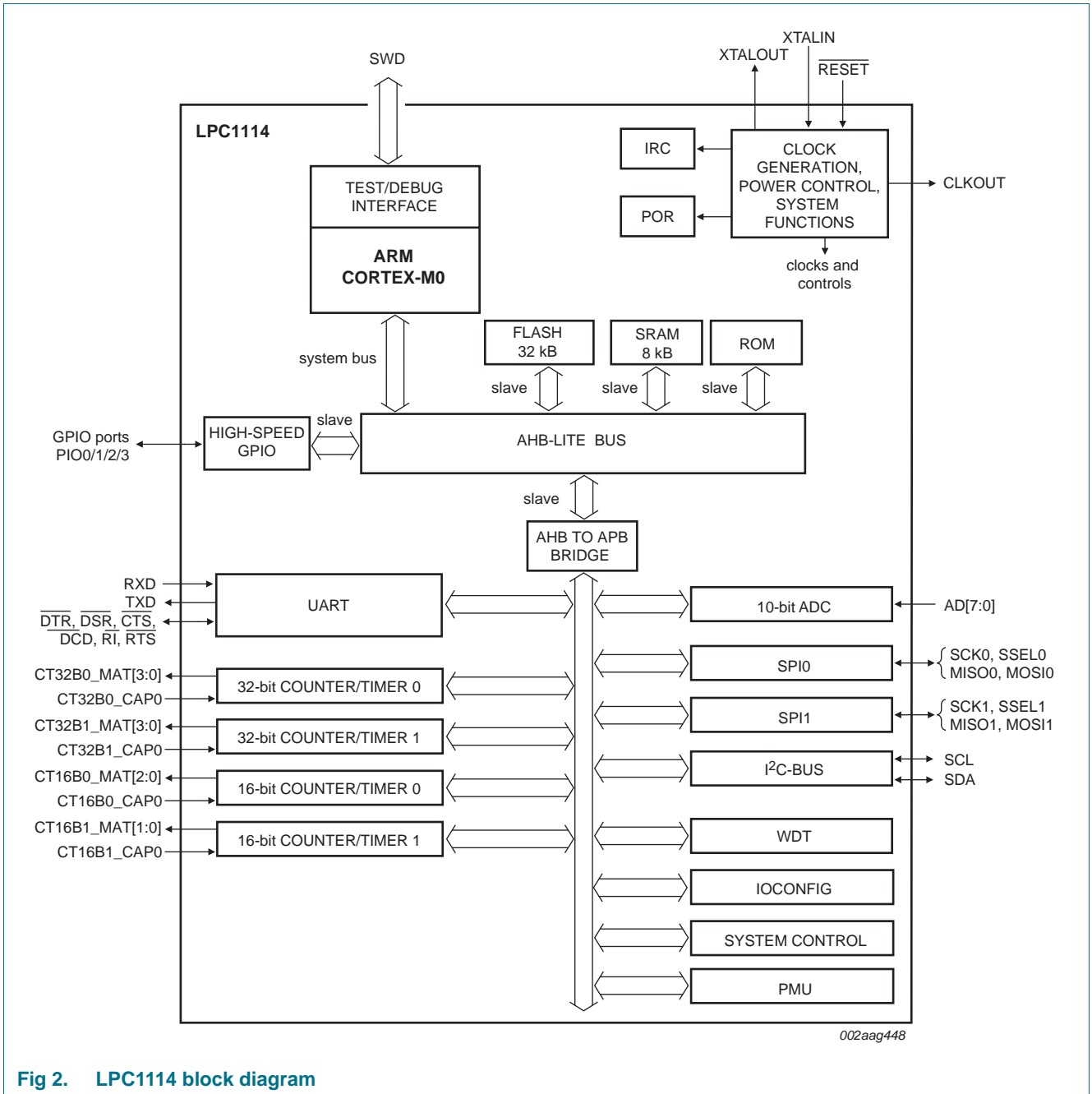

Fig 2. LPC1114 block diagram

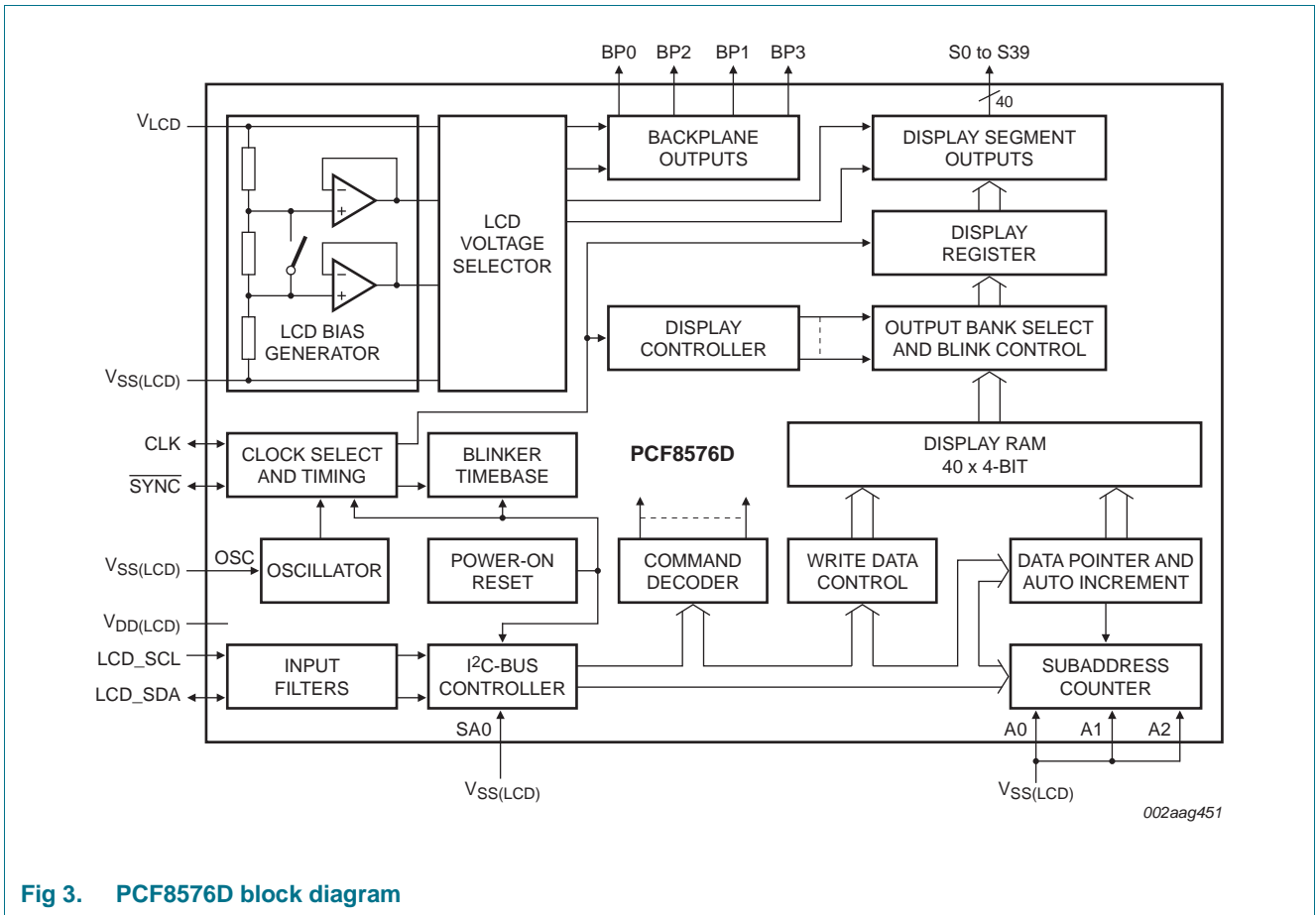

Fig 3. PCF8576D block diagram

## 6. Pinning information

### 6.1 Pinning

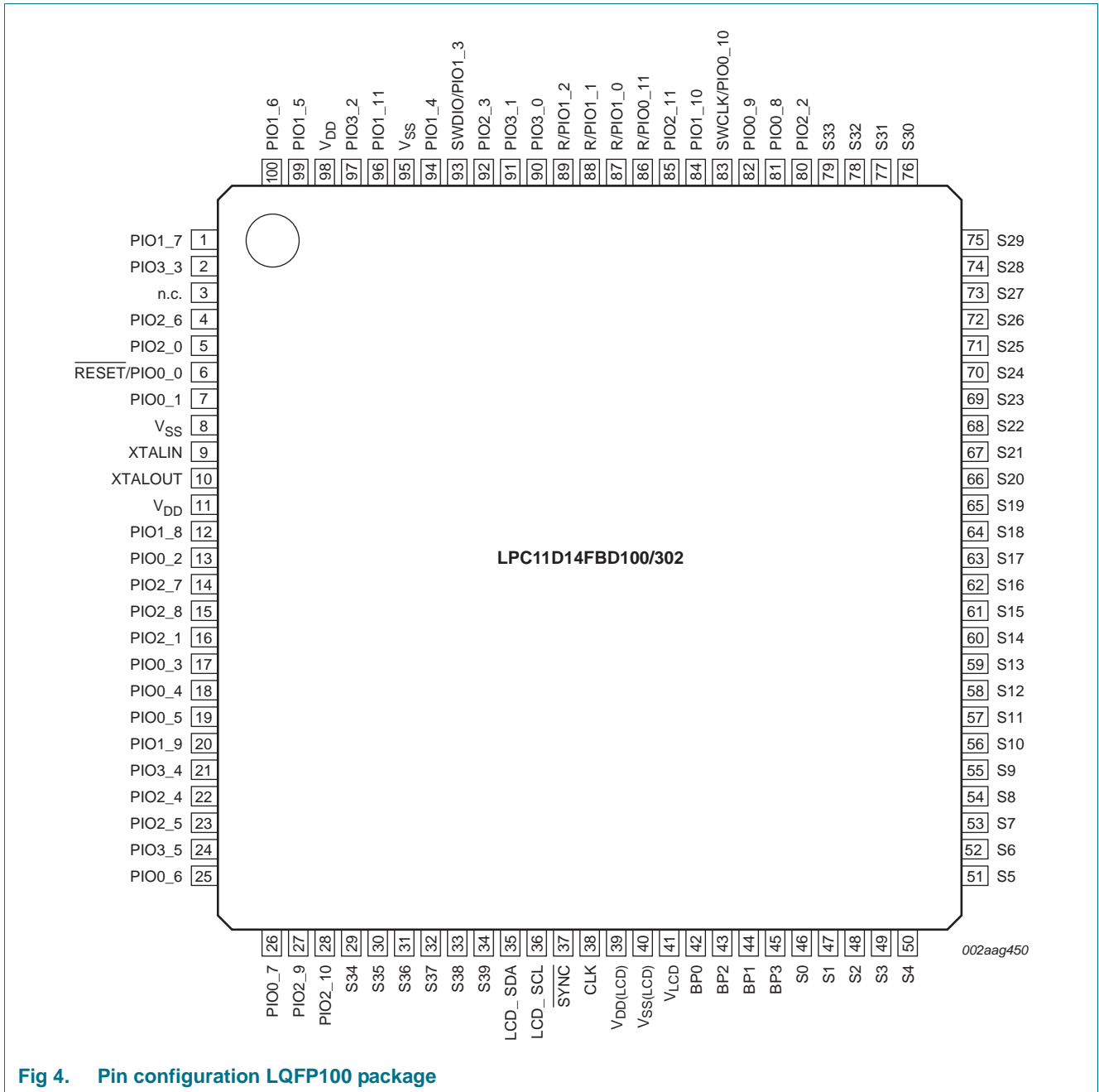

Fig 4. Pin configuration LQFP100 package

## 6.2 Pin description

Table 3. LPC11D14 pin description table (LQFP100 package)

Symbol	Pin	Start logic input	Type	Reset state [1]	Description
<b>Microcontroller pins</b>					
PIO0_0 to PIO0_11			I/O		<b>Port 0</b> — Port 0 is a 12-bit I/O port with individual direction and function controls for each bit. The operation of port 0 pins depends on the function selected through the IOCONFIG register block.
RESET/PIO0_0	6[2]	yes	I	I; PU	<b>RESET</b> — External reset input with 20 ns glitch filter. A LOW-going pulse as short as 50 ns on this pin resets the device, causing I/O ports and peripherals to take on their default states, and processor execution to begin at address 0.
			I/O	-	<b>PIO0_0</b> — General purpose digital input/output pin with 10 ns glitch filter.
PIO0_1/CLKOUT/ CT32B0_MAT2	7[3]	yes	I/O	I; PU	<b>PIO0_1</b> — General purpose digital input/output pin. A LOW level on this pin during reset starts the ISP command handler.
			O	-	<b>CLKOUT</b> — Clockout pin.
			O	-	<b>CT32B0_MAT2</b> — Match output 2 for 32-bit timer 0.
PIO0_2/SSEL0/ CT16B0_CAP0	13[3]	yes	I/O	I; PU	<b>PIO0_2</b> — General purpose digital input/output pin.
			I/O	-	<b>SSEL0</b> — Slave Select for SPI0.
			I	-	<b>CT16B0_CAP0</b> — Capture input 0 for 16-bit timer 0.
PIO0_3	17[3]	yes	I/O	I; PU	<b>PIO0_3</b> — General purpose digital input/output pin.
PIO0_4/SCL	18[4]	yes	I/O	I; IA	<b>PIO0_4</b> — General purpose digital input/output pin (open-drain).
			I/O	-	<b>SCL</b> — I <sup>2</sup> C-bus, open-drain clock input/output. High-current sink only if I <sup>2</sup> C Fast-mode Plus is selected in the I/O configuration register.
PIO0_5/SDA	19[4]	yes	I/O	I; IA	<b>PIO0_5</b> — General purpose digital input/output pin (open-drain).
			I/O	-	<b>SDA</b> — I <sup>2</sup> C-bus, open-drain data input/output. High-current sink only if I <sup>2</sup> C Fast-mode Plus is selected in the I/O configuration register.
PIO0_6/SCK0	25[3]	yes	I/O	I; PU	<b>PIO0_6</b> — General purpose digital input/output pin.
			I/O	-	<b>SCK0</b> — Serial clock for SPI0.
PIO0_7/CTS	26[3]	yes	I/O	I; PU	<b>PIO0_7</b> — General purpose digital input/output pin (high-current output driver).
			I	-	<b>CTS</b> — Clear To Send input for UART.
PIO0_8/MISO0/ CT16B0_MAT0	81[3]	yes	I/O	I; PU	<b>PIO0_8</b> — General purpose digital input/output pin.
			I/O	-	<b>MISO0</b> — Master In Slave Out for SPI0.
			O	-	<b>CT16B0_MAT0</b> — Match output 0 for 16-bit timer 0.
PIO0_9/MOSI0/ CT16B0_MAT1	82[3]	yes	I/O	I; PU	<b>PIO0_9</b> — General purpose digital input/output pin.
			I/O	-	<b>MOSI0</b> — Master Out Slave In for SPI0.
			O	-	<b>CT16B0_MAT1</b> — Match output 1 for 16-bit timer 0.

Table 3. LPC11D14 pin description table (LQFP100 package) ...continued

Symbol	Pin	Start logic input	Type	Reset state [1]	Description
SWCLK/PIO0_10/ SCK0/ CT16B0_MAT2	83[3]	yes	I	I; PU	<b>SWCLK</b> — Serial wire clock.
			I/O	-	<b>PIO0_10</b> — General purpose digital input/output pin.
			I/O	-	<b>SCK0</b> — Serial clock for SPI0.
			O	-	<b>CT16B0_MAT2</b> — Match output 2 for 16-bit timer 0.
R/PIO0_11/ AD0/CT32B0_MAT3	86[5]	yes	I	I; PU	<b>R</b> — Reserved. Configure for an alternate function in the IOCONFIG block.
			I/O	-	<b>PIO0_11</b> — General purpose digital input/output pin.
			I	-	<b>AD0</b> — A/D converter, input 0.
			O	-	<b>CT32B0_MAT3</b> — Match output 3 for 32-bit timer 0.
PIO1_0 to PIO1_11			I/O		<b>Port 1</b> — Port 1 is a 12-bit I/O port with individual direction and function controls for each bit. The operation of port 1 pins depends on the function selected through the IOCONFIG register block.
R/PIO1_0/ AD1/CT32B1_CAP0	87[5]	yes	I	I; PU	<b>R</b> — Reserved. Configure for an alternate function in the IOCONFIG block.
			I/O	-	<b>PIO1_0</b> — General purpose digital input/output pin.
			I	-	<b>AD1</b> — A/D converter, input 1.
			I	-	<b>CT32B1_CAP0</b> — Capture input 0 for 32-bit timer 1.
R/PIO1_1/ AD2/CT32B1_MAT0	88[5]	no	O	I; PU	<b>R</b> — Reserved. Configure for an alternate function in the IOCONFIG block.
			I/O	-	<b>PIO1_1</b> — General purpose digital input/output pin.
			I	-	<b>AD2</b> — A/D converter, input 2.
			O	-	<b>CT32B1_MAT0</b> — Match output 0 for 32-bit timer 1.
R/PIO1_2/ AD3/CT32B1_MAT1	89[5]	no	I	I; PU	<b>R</b> — Reserved. Configure for an alternate function in the IOCONFIG block.
			I/O	-	<b>PIO1_2</b> — General purpose digital input/output pin.
			I	-	<b>AD3</b> — A/D converter, input 3.
			O	-	<b>CT32B1_MAT1</b> — Match output 1 for 32-bit timer 1.
SWDIO/PIO1_3/ AD4/CT32B1_MAT2	93[5]	no	I/O	I; PU	<b>SWDIO</b> — Serial wire debug input/output.
			I/O	-	<b>PIO1_3</b> — General purpose digital input/output pin.
			I	-	<b>AD4</b> — A/D converter, input 4.
			O	-	<b>CT32B1_MAT2</b> — Match output 2 for 32-bit timer 1.
PIO1_4/AD5/ CT32B1_MAT3/ WAKEUP	94[5]	no	I/O	I; PU	<b>PIO1_4</b> — General purpose digital input/output pin with 10 ns glitch filter.
			I	-	<b>AD5</b> — A/D converter, input 5.
			O	-	<b>CT32B1_MAT3</b> — Match output 3 for 32-bit timer 1.
			I	-	<b>WAKEUP</b> — Deep power-down mode wake-up pin with 20 ns glitch filter. This pin must be pulled HIGH externally to enter Deep power-down mode and pulled LOW to exit Deep power-down mode. A LOW-going pulse as short as 50 ns wakes up the part.



Table 3. LPC11D14 pin description table (LQFP100 package) ...continued

Symbol	Pin	Start logic input	Type	Reset state [1]	Description
PIO1_5/ $\overline{\text{RTS}}$ / CT32B0_CAP0	99 <sup>[3]</sup>	no	I/O	I; PU	<b>PIO1_5</b> — General purpose digital input/output pin.
			O	-	$\overline{\text{RTS}}$ — Request To Send output for UART.
			I	-	<b>CT32B0_CAP0</b> — Capture input 0 for 32-bit timer 0.
PIO1_6/RXD/ CT32B0_MAT0	100 <sup>[3]</sup>	no	I/O	I; PU	<b>PIO1_6</b> — General purpose digital input/output pin.
			I	-	<b>RXD</b> — Receiver input for UART.
			O	-	<b>CT32B0_MAT0</b> — Match output 0 for 32-bit timer 0.
PIO1_7/TXD/ CT32B0_MAT1	1 <sup>[3]</sup>	no	I/O	I; PU	<b>PIO1_7</b> — General purpose digital input/output pin.
			O	-	<b>TXD</b> — Transmitter output for UART.
			O	-	<b>CT32B0_MAT1</b> — Match output 1 for 32-bit timer 0.
PIO1_8/ CT16B1_CAP0	12 <sup>[3]</sup>	no	I/O	I; PU	<b>PIO1_8</b> — General purpose digital input/output pin.
			I	-	<b>CT16B1_CAP0</b> — Capture input 0 for 16-bit timer 1.
PIO1_9/ CT16B1_MAT0	20 <sup>[3]</sup>	no	I/O	I; PU	<b>PIO1_9</b> — General purpose digital input/output pin.
			O	-	<b>CT16B1_MAT0</b> — Match output 0 for 16-bit timer 1.
PIO1_10/AD6/ CT16B1_MAT1	84 <sup>[5]</sup>	no	I/O	I; PU	<b>PIO1_10</b> — General purpose digital input/output pin.
			I	-	<b>AD6</b> — A/D converter, input 6.
			O	-	<b>CT16B1_MAT1</b> — Match output 1 for 16-bit timer 1.
PIO1_11/AD7	96 <sup>[5]</sup>	no	I/O	I; PU	<b>PIO1_11</b> — General purpose digital input/output pin.
			I	-	<b>AD7</b> — A/D converter, input 7.
PIO2_0 to PIO2_11			I/O		<b>Port 2</b> — Port 2 is a 12-bit I/O port with individual direction and function controls for each bit. The operation of port 2 pins depends on the function selected through the IOCONFIG register block.
PIO2_0/ $\overline{\text{DTR}}$ /SSEL1	5 <sup>[3]</sup>	no	I/O	I; PU	<b>PIO2_0</b> — General purpose digital input/output pin.
			O	-	$\overline{\text{DTR}}$ — Data Terminal Ready output for UART.
			I/O	-	<b>SSEL1</b> — Slave Select for SPI1.
PIO2_1/ $\overline{\text{DSR}}$ /SCK1	16 <sup>[3]</sup>	no	I/O	I; PU	<b>PIO2_1</b> — General purpose digital input/output pin.
			I	-	$\overline{\text{DSR}}$ — Data Set Ready input for UART.
			I/O	-	<b>SCK1</b> — Serial clock for SPI1.
PIO2_2/ $\overline{\text{DCD}}$ /MISO1	80 <sup>[3]</sup>	no	I/O	I; PU	<b>PIO2_2</b> — General purpose digital input/output pin.
			I	-	$\overline{\text{DCD}}$ — Data Carrier Detect input for UART.
			I/O	-	<b>MISO1</b> — Master In Slave Out for SPI1.
PIO2_3/ $\overline{\text{RI}}$ /MOSI1	92 <sup>[3]</sup>	no	I/O	I; PU	<b>PIO2_3</b> — General purpose digital input/output pin.
			I	-	$\overline{\text{RI}}$ — Ring Indicator input for UART.
			I/O	-	<b>MOSI1</b> — Master Out Slave In for SPI1.
PIO2_4	22 <sup>[3]</sup>	no	I/O	I; PU	<b>PIO2_4</b> — General purpose digital input/output pin.
PIO2_5	23 <sup>[3]</sup>	no	I/O	I; PU	<b>PIO2_5</b> — General purpose digital input/output pin.
PIO2_6	4 <sup>[3]</sup>	no	I/O	I; PU	<b>PIO2_6</b> — General purpose digital input/output pin.
PIO2_7	14 <sup>[3]</sup>	no	I/O	I; PU	<b>PIO2_7</b> — General purpose digital input/output pin.
PIO2_8	15 <sup>[3]</sup>	no	I/O	I; PU	<b>PIO2_8</b> — General purpose digital input/output pin.
PIO2_9	27 <sup>[3]</sup>	no	I/O	I; PU	<b>PIO2_9</b> — General purpose digital input/output pin.

Table 3. LPC11D14 pin description table (LQFP100 package) ...continued

Symbol	Pin	Start logic input	Type	Reset state [1]	Description
PIO2_10	28[3]	no	I/O	I; PU	<b>PIO2_10</b> — General purpose digital input/output pin.
PIO2_11/SCK0	85[3]	no	I/O	I; PU	<b>PIO2_11</b> — General purpose digital input/output pin.
			I/O	-	<b>SCK0</b> — Serial clock for SPI0.
PIO3_0 to PIO3_5			I/O		<b>Port 3</b> — Port 3 is a 12-bit I/O port with individual direction and function controls for each bit. The operation of port 3 pins depends on the function selected through the IOCONFIG register block. Pins PIO3_6 to PIO3_11 are not available.
PIO3_0/DTR	90[3]	no	I/O	I; PU	<b>PIO3_0</b> — General purpose digital input/output pin.
			O	-	<b>DTR</b> — Data Terminal Ready output for UART.
PIO3_1/DSR	91[3]	no	I/O	I; PU	<b>PIO3_1</b> — General purpose digital input/output pin.
			I	-	<b>DSR</b> — Data Set Ready input for UART.
PIO3_2/DCD	97[3]	no	I/O	I; PU	<b>PIO3_2</b> — General purpose digital input/output pin.
			I	-	<b>DCD</b> — Data Carrier Detect input for UART.
PIO3_3/RI	2[3]	no	I/O	I; PU	<b>PIO3_3</b> — General purpose digital input/output pin.
			I	-	<b>RI</b> — Ring Indicator input for UART.
PIO3_4	21[3]	no	I/O	I; PU	<b>PIO3_4</b> — General purpose digital input/output pin.
PIO3_5	24[3]	no	I/O	I; PU	<b>PIO3_5</b> — General purpose digital input/output pin.
V <sub>DD</sub>	11; 98	-	I	-	3.3 V supply voltage to the internal regulator, the external rail, and the ADC. Also used as the ADC reference voltage.
XTALIN	9[6]	-	I	-	Input to the oscillator circuit and internal clock generator circuits. Input voltage must not exceed 1.8 V.
XTALOUT	10[6]	-	O	-	Output from the oscillator amplifier.
V <sub>SS</sub>	8; 95	-	I	-	Ground.
<b>LCD display pins</b>					
S0	46	-	O	V <sub>LCD</sub> [7]	LCD segment output.
S1	47	-	O	V <sub>LCD</sub> [7]	LCD segment output.
S2	48	-	O	V <sub>LCD</sub> [7]	LCD segment output.
S3	49	-	O	V <sub>LCD</sub> [7]	LCD segment output.
S4	50	-	O	V <sub>LCD</sub> [7]	LCD segment output.
S5	51	-	O	V <sub>LCD</sub> [7]	LCD segment output.
S6	52	-	O	V <sub>LCD</sub> [7]	LCD segment output.
S7	53	-	O	V <sub>LCD</sub> [7]	LCD segment output.
S8	54	-	O	V <sub>LCD</sub> [7]	LCD segment output.
S9	55	-	O	V <sub>LCD</sub> [7]	LCD segment output.
S10	56	-	O	V <sub>LCD</sub> [7]	LCD segment output.
S11	57	-	O	V <sub>LCD</sub> [7]	LCD segment output.
S12	58	-	O	V <sub>LCD</sub> [7]	LCD segment output.
S13	59	-	O	V <sub>LCD</sub> [7]	LCD segment output.
S14	60	-	O	V <sub>LCD</sub> [7]	LCD segment output.
S15	61	-	O	V <sub>LCD</sub> [7]	LCD segment output.
S16	62	-	O	V <sub>LCD</sub> [7]	LCD segment output.

Table 3. LPC11D14 pin description table (LQFP100 package) ...continued

Symbol	Pin	Start logic input	Type	Reset state [1]	Description
S17	63	-	O	V <sub>LCD</sub> [7]	LCD segment output.
S18	64	-	O	V <sub>LCD</sub> [7]	LCD segment output.
S19	65	-	O	V <sub>LCD</sub> [7]	LCD segment output.
S20	66	-	O	V <sub>LCD</sub> [7]	LCD segment output.
S21	67	-	O	V <sub>LCD</sub> [7]	LCD segment output.
S22	68	-	O	V <sub>LCD</sub> [7]	LCD segment output.
S23	69	-	O	V <sub>LCD</sub> [7]	LCD segment output.
S24	70	-	O	V <sub>LCD</sub> [7]	LCD segment output.
S25	71	-	O	V <sub>LCD</sub> [7]	LCD segment output.
S26	72	-	O	V <sub>LCD</sub> [7]	LCD segment output.
S27	73	-	O	V <sub>LCD</sub> [7]	LCD segment output.
S28	74	-	O	V <sub>LCD</sub> [7]	LCD segment output.
S29	75	-	O	V <sub>LCD</sub> [7]	LCD segment output.
S30	76	-	O	V <sub>LCD</sub> [7]	LCD segment output.
S31	77	-	O	V <sub>LCD</sub> [7]	LCD segment output.
S32	78	-	O	V <sub>LCD</sub> [7]	LCD segment output.
S33	79	-	O	V <sub>LCD</sub> [7]	LCD segment output.
S34	29	-	O	V <sub>LCD</sub> [7]	LCD segment output.
S35	30	-	O	V <sub>LCD</sub> [7]	LCD segment output.
S36	31	-	O	V <sub>LCD</sub> [7]	LCD segment output.
S37	32	-	O	V <sub>LCD</sub> [7]	LCD segment output.
S38	33	-	O	V <sub>LCD</sub> [7]	LCD segment output.
S39	34	-	O	V <sub>LCD</sub> [7]	LCD segment output.
BP0	42	-	O	V <sub>LCD</sub> [7]	LCD backplane output.
BP1	44	-	O	V <sub>LCD</sub> [7]	LCD backplane output.
BP2	43	-	O	V <sub>LCD</sub> [7]	LCD backplane output.
BP3	45	-	O	V <sub>LCD</sub> [7]	LCD backplane output.
LCD_SDA	35	-	I/O	[7]	I <sup>2</sup> C-bus serial data input/output.
LCD_SCL	36	-	I/O	[7]	I <sup>2</sup> C-bus serial clock input.
$\overline{\text{SYNC}}$	37	-	I/O	[7]	Cascade synchronization input/output.
CLK	38	-	I/O	[7]	External clock input/output.
V <sub>DD(LCD)</sub>	39	-	-	-	1.8 V to 5.5 V power supply: Power supply voltage for the PCF8576D.
V <sub>SS(LCD)</sub>	40	-	-	-	LCD ground. The PCF8576 input signals A0, A1, A2, SA0, and OSC are internally hard-wired to V <sub>SS(LCD)</sub> .
V <sub>LCD</sub>	41	-	-	-	LCD power supply; LCD voltage.
n.c.	3	-	-	-	Not connected.

[1] Pin state at reset for default function: I = Input; O = Output; PU = internal pull-up enabled (pins pulled up to full V<sub>DD</sub> level (V<sub>DD</sub> = 3.3 V)); IA = inactive, no pull-up/down enabled.

- [2]  $\overline{\text{RESET}}$  functionality is not available in Deep power-down mode. Use the WAKEUP pin to reset the chip and wake up from Deep power-down mode. An external pull-up resistor is required on this pin for the Deep power-down mode.
- [3] 5 V tolerant pad providing digital I/O functions with configurable pull-up/pull-down resistors and configurable hysteresis.
- [4] I<sup>2</sup>C-bus pads compliant with the I<sup>2</sup>C-bus specification for I<sup>2</sup>C standard mode and I<sup>2</sup>C Fast-mode Plus.
- [5] 5 V tolerant pad providing digital I/O functions with configurable pull-up/pull-down resistors, configurable hysteresis, and analog input. When configured as a ADC input, digital section of the pad is disabled and the pin is not 5 V tolerant.
- [6] When the system oscillator is not used, connect XTALIN and XTALOUT as follows: XTALIN can be left floating or can be grounded (grounding is preferred to reduce susceptibility to noise). XTALOUT should be left floating.
- [7] See [Section 7.2.3](#).

## 7. Functional description

### 7.1 LPC1114 microcontroller

See [Ref. 1](#) for a detailed functional description of the LPC1114 microcontroller.

### 7.2 LCD driver

See [Ref. 2](#) for a detailed functional description of the PCF8576D LCD driver.

#### 7.2.1 General description

The PCF8576D is a peripheral device which interfaces to almost any Liquid Crystal Display (LCD) with low multiplex rates. It generates the drive signals for any static or multiplexed LCD containing up to four backplanes and up to 40 segments. It can be easily cascaded for larger LCD applications. The PCF8576D communicates via the two-line bidirectional I<sup>2</sup>C-bus. Communication overheads are minimized by a display RAM with auto-incremented addressing, by hardware subaddressing and by display memory switching (static and duplex drive modes). Please refer to PCF8576D data sheet for electrical data.

#### 7.2.2 Functional description

The PCF8576D is a versatile peripheral device interfacing the LPC1114 microcontroller with a wide variety of LCDs. It can directly drive any static or multiplexed LCD containing up to four backplanes and up to 40 segments.

The possible display configurations of the PCF8576D depend on the number of active backplane outputs required. A selection of display configurations is shown in [Table 4](#). The integration of the LPC1114 microcontroller with the PCF8576D is shown in [Figure 1](#).

**Table 4. Selection of display configurations**

Number of Backplanes	Segments	Digits/Characters		
		7-segment	14-segment	Dot matrix/Elements
4	160	20	10	160 (4 × 40)
3	120	15	7	120 (3 × 40)
2	80	10	5	64 (2 × 40)
1	40	5	2	40 (1 × 40)

#### 7.2.3 Reset state of the LCD controller and pins

After power-on, the LCD controller resets to the following starting conditions:

- All backplane and segment outputs are set to  $V_{LCD}$ .
- The selected drive mode is 1:4 multiplex with 1/3 bias.
- Blinking is switched off.
- Input and output bank selectors are reset.
- The I<sup>2</sup>C-bus interface is initialized.
- The data pointer and the subaddress counter are cleared (set to logic 0).
- The display is disabled.

**Remark:** Do not transfer data on the I<sup>2</sup>C-bus for at least 1 ms after a power-on to allow the reset action to complete.

### 7.2.4 LCD bias generator

Fractional LCD biasing voltages are obtained from an internal voltage divider consisting of three impedances connected in series between  $V_{LCD}$  and  $V_{SS(LCD)}$ . The middle resistor can be bypassed to provide a 1/2 bias voltage level for the 1:2 multiplex configuration. The LCD voltage can be temperature compensated externally using the supply to pin  $V_{LCD}$ .

### 7.2.5 Oscillator

#### 7.2.5.1 Internal clock

The internal logic of the PCF8576D and the LCD drive signals are timed by the internal oscillator. The internal oscillator is always enabled. The output from pin CLK can be used as the clock signal for several PCF8576Ds in the system that are connected in cascade.

### 7.2.6 Timing

The PCF8576D timing controls the internal data flow of the device. This includes the transfer of display data from the display RAM to the display segment outputs. In cascaded applications, the correct timing relationship between each PCF8576D in the system is maintained by the synchronization signal at pin SYNC. The timing also generates the LCD frame signal whose frequency is derived from the clock frequency. The frame signal frequency ( $f_{fr}$ ) is a fixed division of the clock frequency ( $f_{clk}$ ) from either the internal or an external clock:  $f_{fr} = f_{clk}/24$ .

### 7.2.7 Display register

A display latch holds the display data while the corresponding multiplex signals are generated. There is a one-to-one relationship between the data in the display latch, the LCD segment outputs, and each column of the display RAM.

### 7.2.8 Segment outputs

The LCD drive section includes 40 segment outputs S0 to S39 which should be connected directly to the LCD. The segment output signals are generated in accordance with the multiplexed backplane signals and with data residing in the display latch. When less than 40 segment outputs are required, the unused segment outputs should be left open-circuit.

### 7.2.9 Backplane outputs

The LCD drive section includes four backplane outputs BP0 to BP3 which must be connected directly to the LCD. The backplane output signals are generated in accordance with the selected LCD drive mode. If less than four backplane outputs are required, the unused outputs can be left open-circuit.

In the 1:3 multiplex drive mode, BP3 carries the same signal as BP1, therefore these two adjacent outputs can be tied together to give enhanced drive capabilities.

In the 1:2 multiplex drive mode, BP0 and BP2, BP1 and BP3 all carry the same signals and may also be paired to increase the drive capabilities.

In the static drive mode the same signal is carried by all four backplane outputs and they can be connected in parallel for very high drive requirements.

#### 7.2.10 Display RAM

The display RAM is a static  $40 \times 4$ -bit RAM which stores LCD data. There is a one-to-one correspondence between the RAM addresses and the segment outputs, and between the individual bits of a RAM word and the backplane outputs. For details, see [Ref. 2](#).

## 8. Limiting values

**Table 5. Limiting values**

In accordance with the Absolute Maximum Rating System (IEC 60134).<sup>[1]</sup>

Symbol	Parameter	Conditions	Min	Max	Unit
V <sub>DD</sub>	supply voltage (core and external rail)		1.8	3.6	V
V <sub>I</sub>	input voltage	5 V tolerant I/O pins; only valid when the V <sub>DD</sub> supply voltage is present	<sup>[2]</sup> -0.5	+5.5	V
I <sub>DD</sub>	supply current	per supply pin	-	100	mA
I <sub>SS</sub>	ground current	per ground pin	-	100	mA
I <sub>latch</sub>	I/O latch-up current	-(0.5V <sub>DD</sub> ) < V <sub>I</sub> < (1.5V <sub>DD</sub> ); T <sub>j</sub> < 125 °C	-	100	mA
T <sub>stg</sub>	storage temperature	non-operating	<sup>[3]</sup> -65	+150	°C
T <sub>j(max)</sub>	maximum junction temperature		-	150	°C
P <sub>tot(pack)</sub>	total power dissipation (per package)	based on package heat transfer, not device power consumption	-	1.5	W
V <sub>ESD</sub>	electrostatic discharge voltage	human body model; all pins	<sup>[4]</sup> -6500	+6500	V

[1] The following applies to the limiting values:

- a) This product includes circuitry specifically designed for the protection of its internal devices from the damaging effects of excessive static charge. Nonetheless, it is suggested that conventional precautions be taken to avoid applying greater than the rated maximum.
- b) Parameters are valid over operating temperature range unless otherwise specified. All voltages are with respect to V<sub>SS</sub> unless otherwise noted.

[2] Including voltage on outputs in 3-state mode.

[3] The maximum non-operating storage temperature is different than the temperature for required shelf life which should be determined based on required shelf lifetime. Please refer to the JEDEC spec (J-STD-033B.1) for further details.

[4] Human body model: equivalent to discharging a 100 pF capacitor through a 1.5 kΩ series resistor.



## 9. Static characteristics

**Table 6. Static characteristics**

$T_{amb} = -40\text{ }^{\circ}\text{C}$  to  $+85\text{ }^{\circ}\text{C}$ , unless otherwise specified.

Symbol	Parameter	Conditions	Min	Typ <sup>[1]</sup>	Max	Unit	
$V_{DD}$	supply voltage (core and external rail)		1.8	3.3	3.6	V	
<b>Power consumption in low-current mode<sup>[10]</sup></b>							
$I_{DD}$	supply current	Active mode; code while(1){ executed from flash					
		system clock = 12 MHz $V_{DD} = 3.3\text{ V}$	<a href="#">[2]</a> <a href="#">[3]</a> <a href="#">[4]</a> <a href="#">[5]</a> <a href="#">[6]</a>	-	2	-	mA
		system clock = 50 MHz $V_{DD} = 3.3\text{ V}$	<a href="#">[2]</a> <a href="#">[3]</a> <a href="#">[5]</a> <a href="#">[6]</a> <a href="#">[7]</a>	-	7	-	mA
		Sleep mode; system clock = 12 MHz $V_{DD} = 3.3\text{ V}$	<a href="#">[2]</a> <a href="#">[3]</a> <a href="#">[4]</a> <a href="#">[5]</a> <a href="#">[6]</a>	-	1	-	mA
		Deep-sleep mode; $V_{DD} = 3.3\text{ V}$	<a href="#">[2]</a> <a href="#">[3]</a> <a href="#">[8]</a>	-	2	-	$\mu\text{A}$
		Deep power-down mode; $V_{DD} = 3.3\text{ V}$	<a href="#">[2]</a> <a href="#">[9]</a>	-	220	-	nA
		<b>Standard port pins, RESET</b>					
$I_{IL}$	LOW-level input current	$V_I = 0\text{ V}$ ; on-chip pull-up resistor disabled	-	0.5	10	nA	
$I_{IH}$	HIGH-level input current	$V_I = V_{DD}$ ; on-chip pull-down resistor disabled	-	0.5	10	nA	
$I_{OZ}$	OFF-state output current	$V_O = 0\text{ V}$ ; $V_O = V_{DD}$ ; on-chip pull-up/down resistors disabled	-	0.5	10	nA	
$V_I$	input voltage	pin configured to provide a digital function	<a href="#">[11]</a> <a href="#">[12]</a> <a href="#">[13]</a>	0	-	5.0	V
$V_O$	output voltage	output active	0	-	$V_{DD}$	V	
$V_{IH}$	HIGH-level input voltage		$0.7V_{DD}$	-	-	V	
$V_{IL}$	LOW-level input voltage		-	-	$0.3V_{DD}$	V	
$V_{hys}$	hysteresis voltage		-	0.4	-	V	
$V_{OH}$	HIGH-level output voltage	$2.5\text{ V} \leq V_{DD} \leq 3.6\text{ V}$ ; $I_{OH} = -4\text{ mA}$	$V_{DD} - 0.4$	-	-	V	
		$1.8\text{ V} \leq V_{DD} < 2.5\text{ V}$ ; $I_{OH} = -3\text{ mA}$	$V_{DD} - 0.4$	-	-	V	
$V_{OL}$	LOW-level output voltage	$2.5\text{ V} \leq V_{DD} \leq 3.6\text{ V}$ ; $I_{OL} = 4\text{ mA}$	-	-	0.4	V	
		$1.8\text{ V} \leq V_{DD} < 2.5\text{ V}$ ; $I_{OL} = 3\text{ mA}$	-	-	0.4	V	

**Table 6. Static characteristics ...continued**  
*T<sub>amb</sub> = -40 °C to +85 °C, unless otherwise specified.*

Symbol	Parameter	Conditions	Min	Typ <sup>[1]</sup>	Max	Unit
I <sub>OH</sub>	HIGH-level output current	V <sub>OH</sub> = V <sub>DD</sub> - 0.4 V; 2.5 V ≤ V <sub>DD</sub> ≤ 3.6 V	-4	-	-	mA
		1.8 V ≤ V <sub>DD</sub> < 2.5 V	-3	-	-	mA
I <sub>OL</sub>	LOW-level output current	V <sub>OL</sub> = 0.4 V 2.5 V ≤ V <sub>DD</sub> ≤ 3.6 V	4	-	-	mA
		1.8 V ≤ V <sub>DD</sub> < 2.5 V	3	-	-	mA
I <sub>OHS</sub>	HIGH-level short-circuit output current	V <sub>OH</sub> = 0 V	[14] -	-	-45	mA
I <sub>OLS</sub>	LOW-level short-circuit output current	V <sub>OL</sub> = V <sub>DD</sub>	[14] -	-	50	mA
I <sub>pd</sub>	pull-down current	V <sub>I</sub> = 5 V	10	50	150	μA
I <sub>pu</sub>	pull-up current	V <sub>I</sub> = 0 V; 2.0 V ≤ V <sub>DD</sub> ≤ 3.6 V	-15	-50	-85	μA
		1.8 V ≤ V <sub>DD</sub> < 2.0 V	-10	-50	-85	μA
		V <sub>DD</sub> < V <sub>I</sub> < 5 V	0	0	0	μA
<b>High-drive output pin (PIO0_7)</b>						
I <sub>IL</sub>	LOW-level input current	V <sub>I</sub> = 0 V; on-chip pull-up resistor disabled	-	0.5	10	nA
I <sub>IH</sub>	HIGH-level input current	V <sub>I</sub> = V <sub>DD</sub> ; on-chip pull-down resistor disabled	-	0.5	10	nA
I <sub>OZ</sub>	OFF-state output current	V <sub>O</sub> = 0 V; V <sub>O</sub> = V <sub>DD</sub> ; on-chip pull-up/down resistors disabled	-	0.5	10	nA
V <sub>I</sub>	input voltage	pin configured to provide a digital function	[11][12] 0 [13]	-	5.0	V
V <sub>O</sub>	output voltage	output active	0	-	V <sub>DD</sub>	V
V <sub>IH</sub>	HIGH-level input voltage		0.7V <sub>DD</sub>	-	-	V
V <sub>IL</sub>	LOW-level input voltage		-	-	0.3V <sub>DD</sub>	V
V <sub>hys</sub>	hysteresis voltage		0.4	-	-	V
V <sub>OH</sub>	HIGH-level output voltage	2.5 V ≤ V <sub>DD</sub> ≤ 3.6 V; I <sub>OH</sub> = -20 mA	V <sub>DD</sub> - 0.4	-	-	V
		1.8 V ≤ V <sub>DD</sub> < 2.5 V; I <sub>OH</sub> = -12 mA	V <sub>DD</sub> - 0.4	-	-	V
V <sub>OL</sub>	LOW-level output voltage	2.5 V ≤ V <sub>DD</sub> ≤ 3.6 V; I <sub>OL</sub> = 4 mA	-	-	0.4	V
		1.8 V ≤ V <sub>DD</sub> < 2.5 V; I <sub>OL</sub> = 3 mA	-	-	0.4	V
I <sub>OH</sub>	HIGH-level output current	V <sub>OH</sub> = V <sub>DD</sub> - 0.4 V; 2.5 V ≤ V <sub>DD</sub> ≤ 3.6 V	20	-	-	mA
		1.8 V ≤ V <sub>DD</sub> < 2.5 V	12	-	-	mA

**Table 6. Static characteristics ...continued**  
 $T_{amb} = -40^{\circ}\text{C}$  to  $+85^{\circ}\text{C}$ , unless otherwise specified.

Symbol	Parameter	Conditions	Min	Typ <sup>[1]</sup>	Max	Unit
$I_{OL}$	LOW-level output current	$V_{OL} = 0.4\text{ V}$ $2.5\text{ V} \leq V_{DD} \leq 3.6\text{ V}$	4	-	-	mA
		$1.8\text{ V} \leq V_{DD} < 2.5\text{ V}$	3	-	-	mA
$I_{OLS}$	LOW-level short-circuit output current	$V_{OL} = V_{DD}$	[14] -	-	50	mA
$I_{pd}$	pull-down current	$V_I = 5\text{ V}$	10	50	150	$\mu\text{A}$
$I_{pu}$	pull-up current	$V_I = 0\text{ V}$ $2.0\text{ V} \leq V_{DD} \leq 3.6\text{ V}$	-15	-50	-85	$\mu\text{A}$
		$1.8\text{ V} \leq V_{DD} < 2.0\text{ V}$	-10	-50	-85	$\mu\text{A}$
		$V_{DD} < V_I < 5\text{ V}$	0	0	0	$\mu\text{A}$
<b>I<sup>2</sup>C-bus pins (PIO0_4 and PIO0_5)</b>						
$V_{IH}$	HIGH-level input voltage		$0.7V_{DD}$	-	-	V
$V_{IL}$	LOW-level input voltage		-	-	$0.3V_{DD}$	V
$V_{hys}$	hysteresis voltage		-	$0.05V_{DD}$	-	V
$I_{OL}$	LOW-level output current	$V_{OL} = 0.4\text{ V}$ ; I <sup>2</sup> C-bus pins configured as standard mode pins $2.5\text{ V} \leq V_{DD} \leq 3.6\text{ V}$	3.5	-	-	mA
		$1.8\text{ V} \leq V_{DD} < 2.5\text{ V}$	3	-	-	
$I_{OL}$	LOW-level output current	$V_{OL} = 0.4\text{ V}$ ; I <sup>2</sup> C-bus pins configured as Fast-mode Plus pins $2.5\text{ V} \leq V_{DD} \leq 3.6\text{ V}$	20	-	-	mA
		$1.8\text{ V} \leq V_{DD} < 2.5\text{ V}$	16	-	-	
$I_{LI}$	input leakage current	$V_I = V_{DD}$	[15] -	2	4	$\mu\text{A}$
		$V_I = 5\text{ V}$	-	10	22	$\mu\text{A}$
<b>Oscillator pins</b>						
$V_{i(xtal)}$	crystal input voltage		-0.5	1.8	1.95	V
$V_{o(xtal)}$	crystal output voltage		-0.5	1.8	1.95	V

[1] Typical ratings are not guaranteed. The values listed are at room temperature (25 °C), nominal supply voltages.

[2]  $T_{amb} = 25^{\circ}\text{C}$ .

[3]  $I_{DD}$  measurements were performed with all pins configured as GPIO outputs driven LOW and pull-up resistors disabled.

[4] IRC enabled; system oscillator disabled; system PLL disabled.

[5] BOD disabled.

[6] All peripherals disabled in the SYSAHBCLKCTRL register. Peripheral clocks to UART and SPI0/1 disabled in system configuration block.

[7] IRC disabled; system oscillator enabled; system PLL enabled.

[8] All oscillators and analog blocks turned off in the PDSLEEPCFG register; PDSLEEPCFG = 0x0000 18FF.

[9] WAKEUP pin pulled HIGH externally.

[10] Low-current mode PWR\_LOW\_CURRENT selected when running the set\_power routine in the power profiles.

[11] Including voltage on outputs in 3-state mode.

[12]  $V_{DD}$  supply voltage must be present.

[13] 3-state outputs go into 3-state mode in Deep power-down mode.

[14] Allowed as long as the current limit does not exceed the maximum current allowed by the device.

[15] To  $V_{SS}$ .

**Table 7. ADC static characteristics**

$T_{amb} = -40\text{ }^{\circ}\text{C}$  to  $+85\text{ }^{\circ}\text{C}$  unless otherwise specified; ADC frequency 4.5 MHz,  $V_{DD} = 2.5\text{ V}$  to  $3.6\text{ V}$ .

Symbol	Parameter	Conditions	Min	Typ	Max	Unit
$V_{IA}$	analog input voltage		0	-	$V_{DD}$	V
$C_{ia}$	analog input capacitance		-	-	1	pF
$E_D$	differential linearity error		[1][2]	-	$\pm 1$	LSB
$E_{L(adj)}$	integral non-linearity		[3]	-	$\pm 1.5$	LSB
$E_O$	offset error		[4]	-	$\pm 3.5$	LSB
$E_G$	gain error		[5]	-	0.6	%
$E_T$	absolute error		[6]	-	$\pm 4$	LSB
$R_{vsi}$	voltage source interface resistance		-	-	40	$k\Omega$
$R_i$	input resistance		[7][8]	-	2.5	$M\Omega$

[1] The ADC is monotonic, there are no missing codes.

[2] The differential linearity error ( $E_D$ ) is the difference between the actual step width and the ideal step width. See [Figure 5](#).

[3] The integral non-linearity ( $E_{L(adj)}$ ) is the peak difference between the center of the steps of the actual and the ideal transfer curve after appropriate adjustment of gain and offset errors. See [Figure 5](#).

[4] The offset error ( $E_O$ ) is the absolute difference between the straight line which fits the actual curve and the straight line which fits the ideal curve. See [Figure 5](#).

[5] The gain error ( $E_G$ ) is the relative difference in percent between the straight line fitting the actual transfer curve after removing offset error, and the straight line which fits the ideal transfer curve. See [Figure 5](#).

[6] The absolute error ( $E_T$ ) is the maximum difference between the center of the steps of the actual transfer curve of the non-calibrated ADC and the ideal transfer curve. See [Figure 5](#).

[7]  $T_{amb} = 25\text{ }^{\circ}\text{C}$ ; maximum sampling frequency  $f_s = 400\text{ kSamples/s}$  and analog input capacitance  $C_{ia} = 1\text{ pF}$ .

[8] Input resistance  $R_i$  depends on the sampling frequency  $f_s$ :  $R_i = 1 / (f_s \times C_{ia})$ .

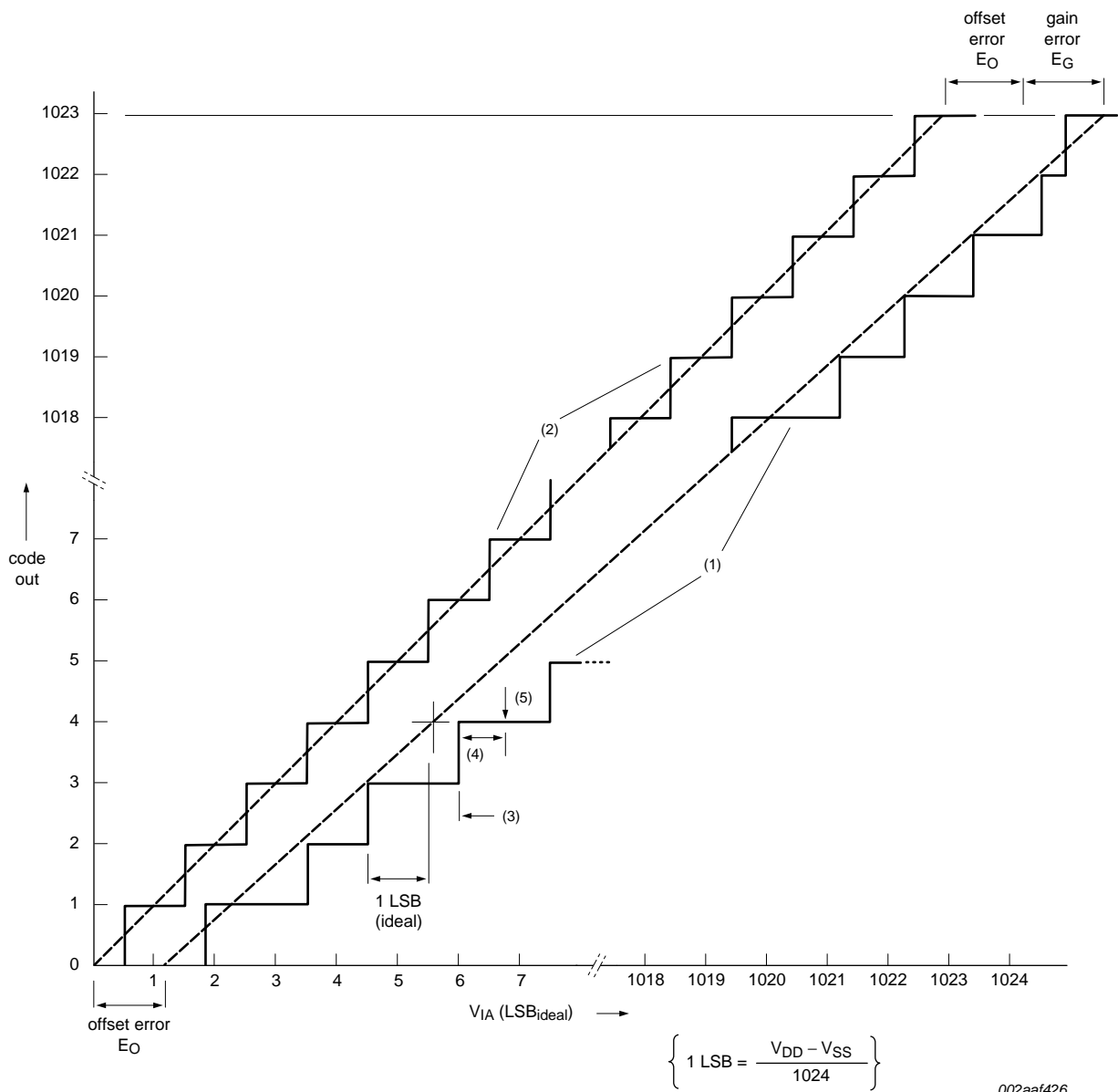

002aaf426

- (1) Example of an actual transfer curve.
- (2) The ideal transfer curve.
- (3) Differential linearity error ( $E_D$ ).
- (4) Integral non-linearity ( $E_{L(adj)}$ ).
- (5) Center of a step of the actual transfer curve.

**Fig 5. ADC characteristics**

## 9.1 BOD static characteristics

**Table 8. BOD static characteristics<sup>[1]</sup>**

$T_{amb} = 25^{\circ}\text{C}$ .

Symbol	Parameter	Conditions	Min	Typ	Max	Unit	
$V_{th}$	threshold voltage	interrupt level 0					
		assertion	-	1.65	-	V	
		de-assertion	-	1.80	-	V	
		interrupt level 1					
		assertion	-	2.22	-	V	
		de-assertion	-	2.35	-	V	
		interrupt level 2					
		assertion	-	2.52	-	V	
		de-assertion	-	2.66	-	V	
		interrupt level 3					
		assertion	-	2.80	-	V	
		de-assertion	-	2.90	-	V	
		reset level 0					
		assertion	-	1.46	-	V	
		de-assertion	-	1.63	-	V	
		reset level 1					
		assertion	-	2.06	-	V	
		de-assertion	-	2.15	-	V	
		reset level 2					
		assertion	-	2.35	-	V	
		de-assertion	-	2.43	-	V	
		reset level 3					
		assertion	-	2.63	-	V	
		de-assertion	-	2.71	-	V	

[1] Interrupt levels are selected by writing the level value to the BOD control register BODCTRL, see *LPC111x user manual*.

## 9.2 Power consumption

Power measurements in Active, Sleep, and Deep-sleep modes were performed under the following conditions (see *LPC111x user manual*):

- Configure all pins as GPIO with pull-up resistor disabled in the IOCONFIG block.
- Configure GPIO pins as outputs using the GPIO nDIR registers.
- Write 0 to all GPIO nDATA registers to drive the outputs LOW.

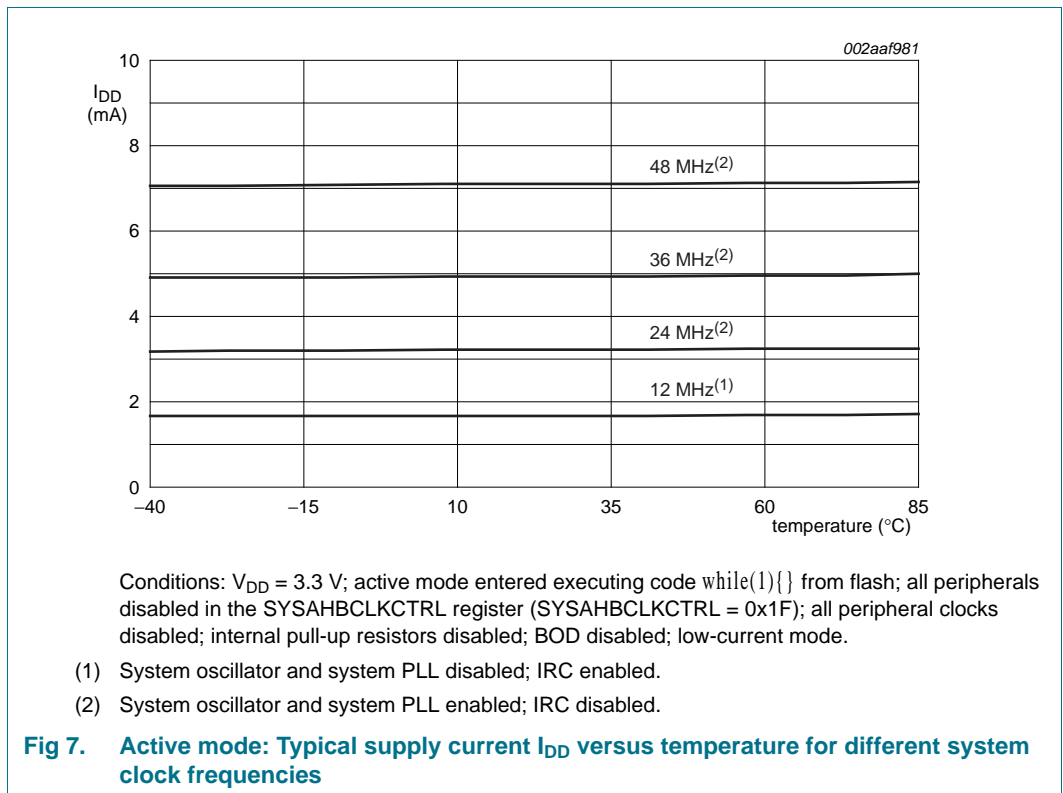
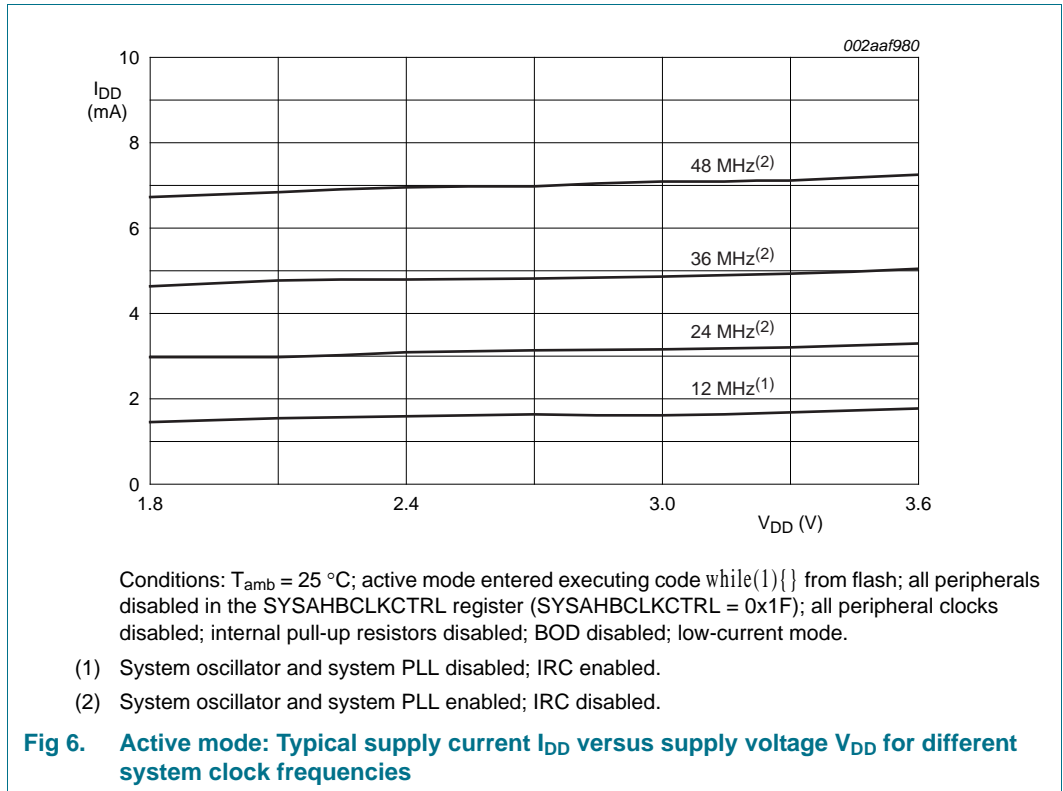

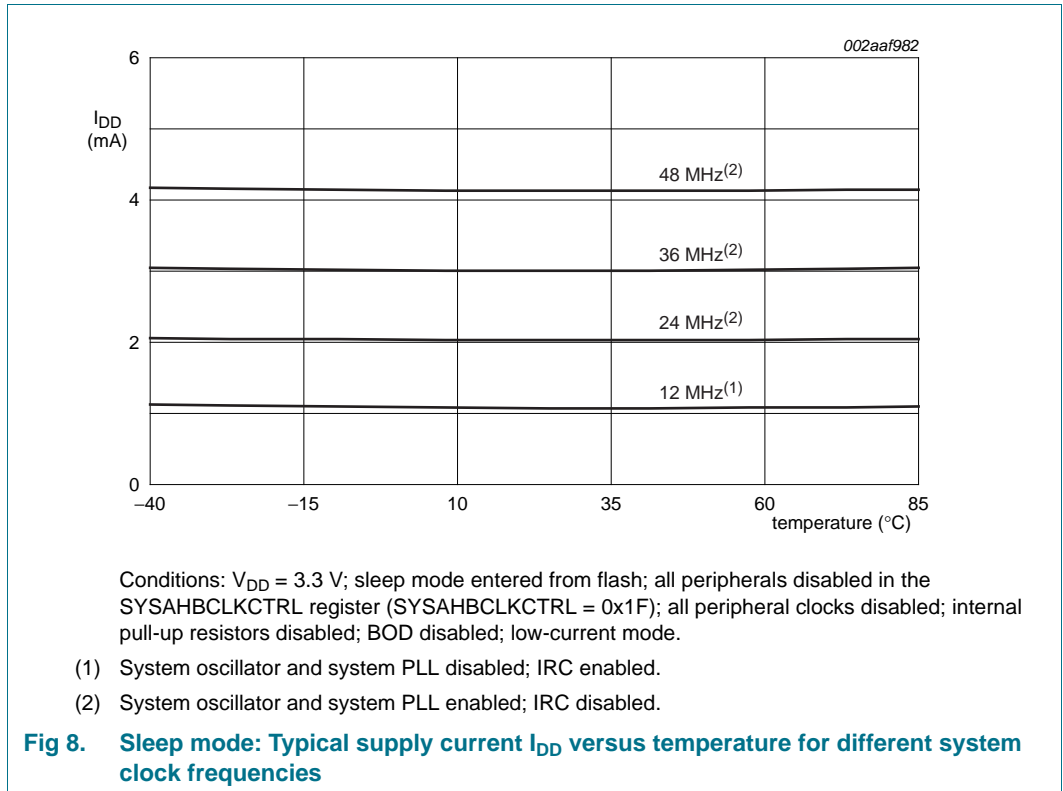



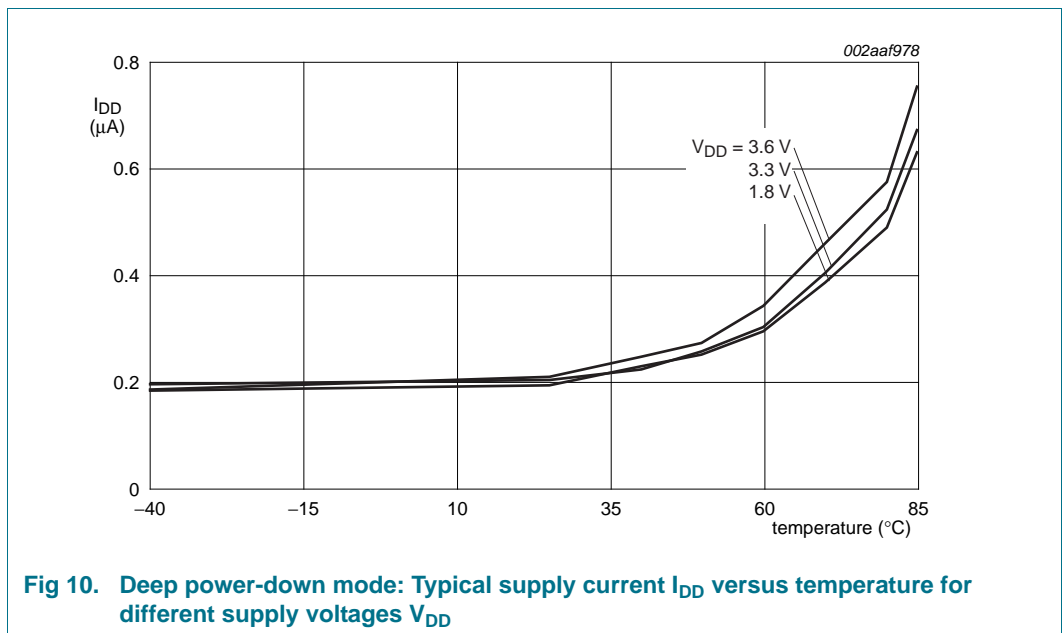
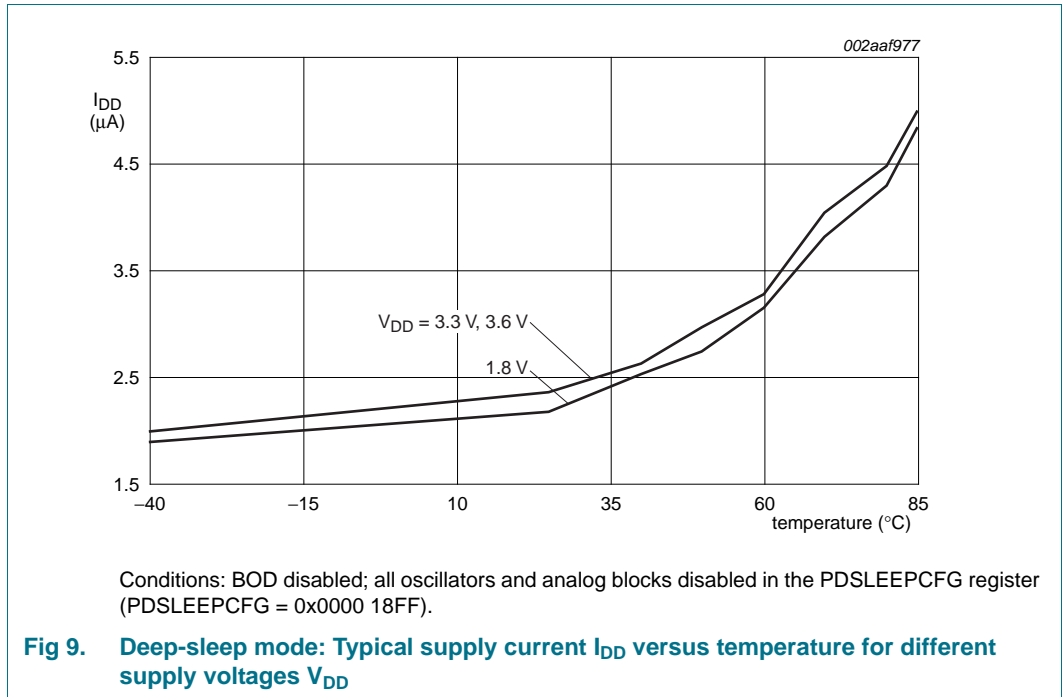

### 9.3 Peripheral power consumption

The supply current per peripheral is measured as the difference in supply current between the peripheral block enabled and the peripheral block disabled in the SYSAHBCLKCFG and PDRUNCFG (for analog blocks) registers. All other blocks are disabled in both registers and no code is executed. Measured on a typical sample at  $T_{amb} = 25\text{ °C}$ . Unless noted otherwise, the system oscillator and PLL are running in both measurements.

The supply currents are shown for system clock frequencies of 12 MHz and 48 MHz.

**Table 9. Power consumption for individual analog and digital blocks**

Peripheral	Typical supply current in mA			Notes
	n/a	12 MHz	48 MHz	
IRC	0.27	-	-	System oscillator running; PLL off; independent of main clock frequency.
System oscillator at 12 MHz	0.22	-	-	IRC running; PLL off; independent of main clock frequency.
Watchdog oscillator at 500 kHz/2	0.004	-	-	System oscillator running; PLL off; independent of main clock frequency.
BOD	0.051	-	-	Independent of main clock frequency.
Main PLL	-	0.21	-	
ADC	-	0.08	0.29	
CLKOUT	-	0.12	0.47	Main clock divided by 4 in the CLKOUTDIV register.
CT16B0	-	0.02	0.06	
CT16B1	-	0.02	0.06	
CT32B0	-	0.02	0.07	
CT32B1	-	0.02	0.06	
GPIO	-	0.23	0.88	GPIO pins configured as outputs and set to LOW. Direction and pin state are maintained if the GPIO is disabled in the SYSAHBCLKCFG register.
IOCONFIG	-	0.03	0.10	
I2C	-	0.04	0.13	
ROM	-	0.04	0.15	
SPI0	-	0.12	0.45	
SPI1	-	0.12	0.45	
UART	-	0.22	0.82	
WDT	-	0.02	0.06	Main clock selected as clock source for the WDT.

9.4 Electrical pin characteristics

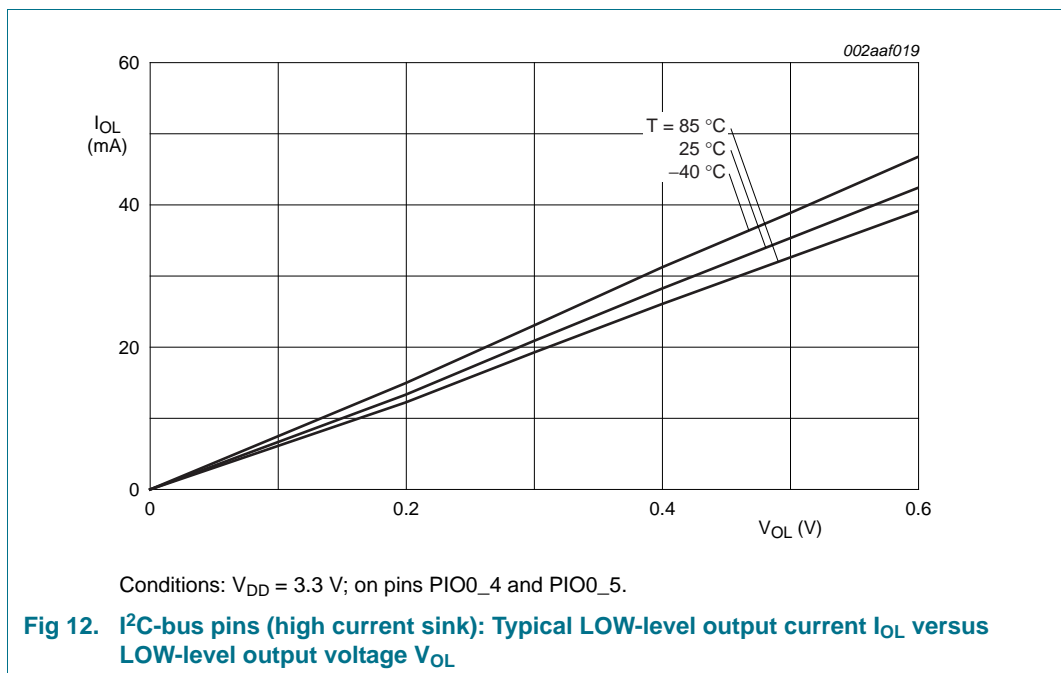
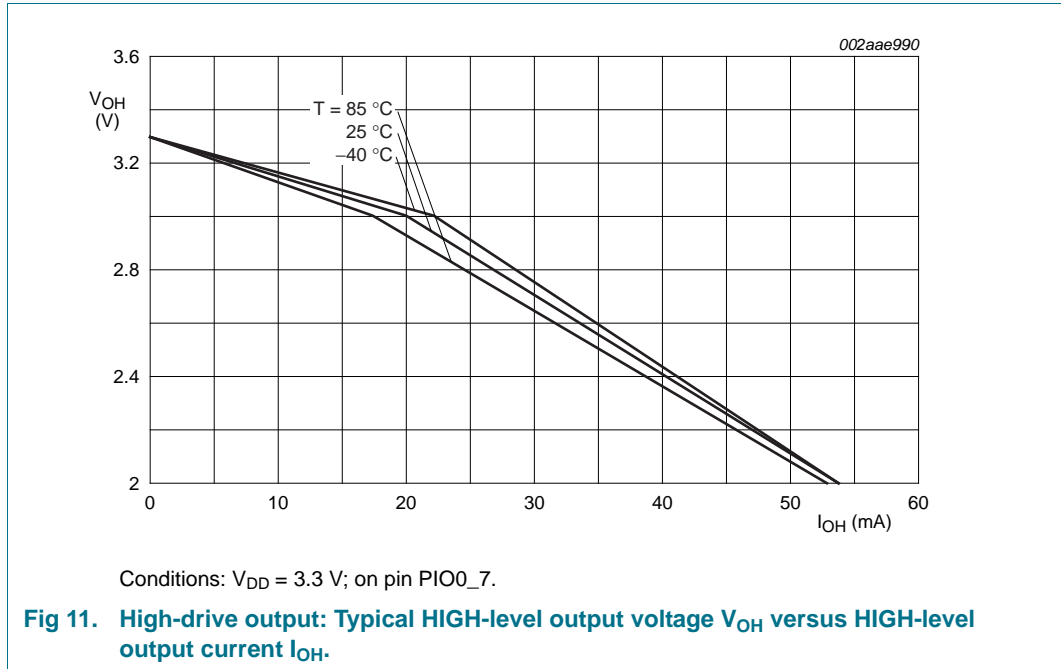

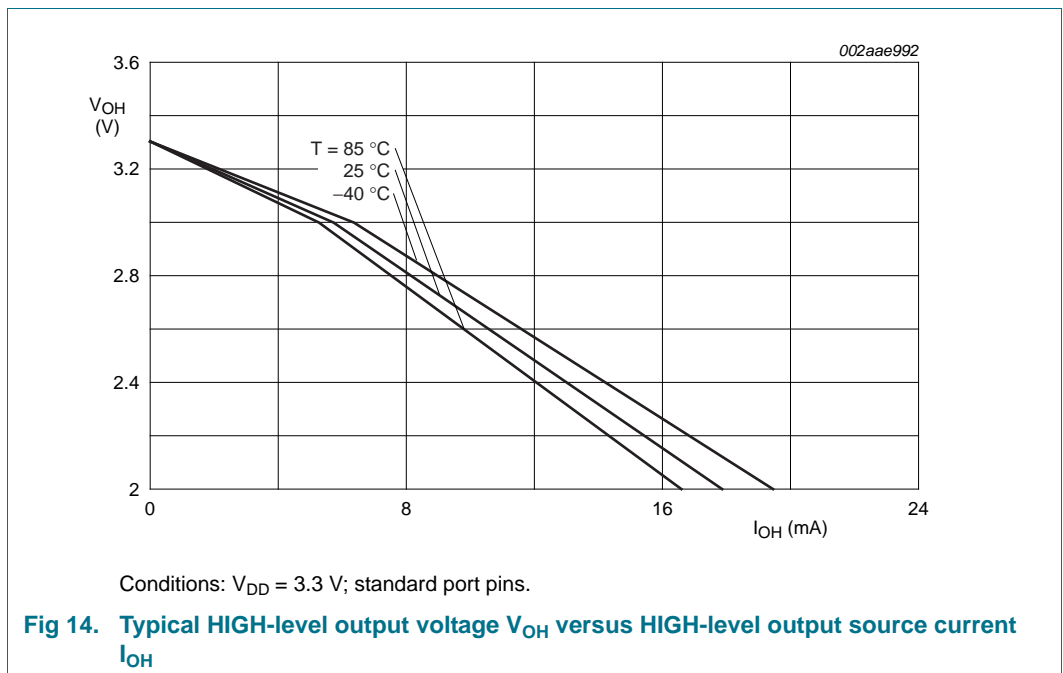
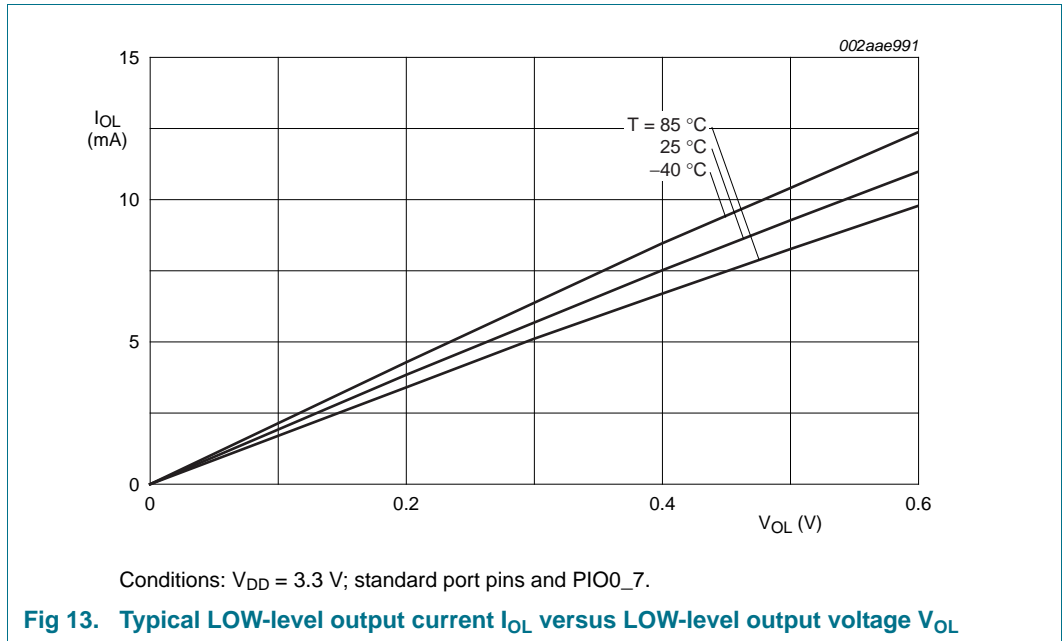

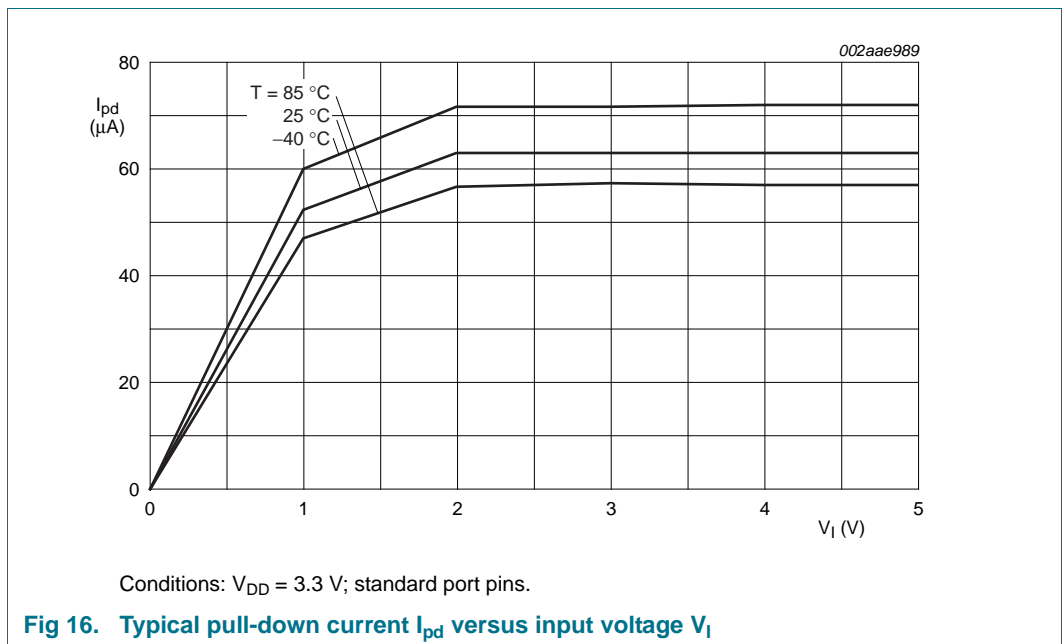
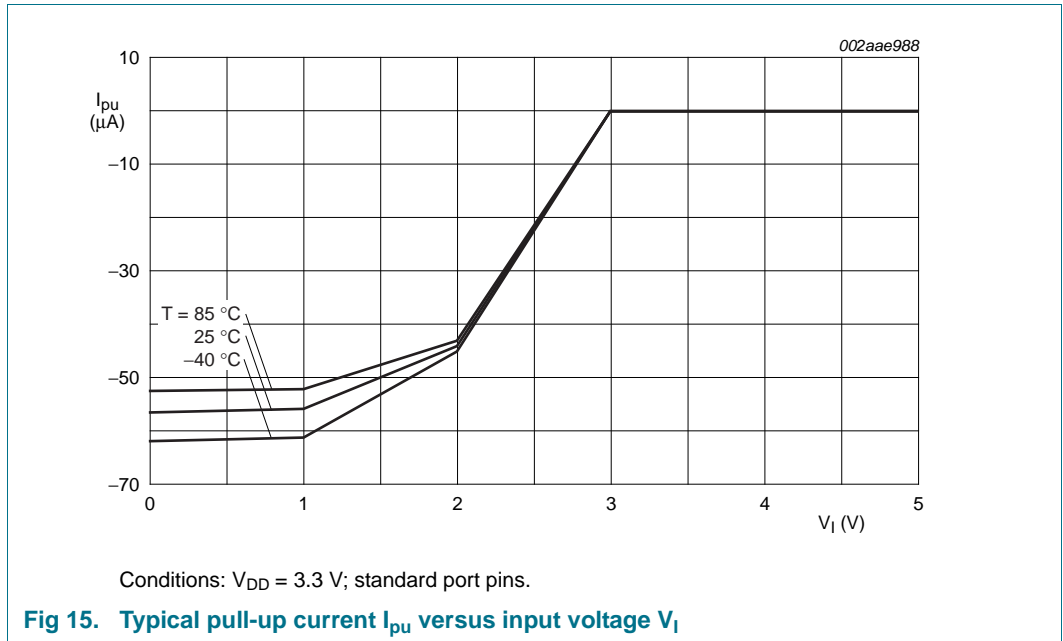

## 10. Dynamic characteristics

### 10.1 Power-up ramp conditions

**Table 10. Power-up characteristics**

$T_{amb} = -40\text{ }^{\circ}\text{C}$  to  $+85\text{ }^{\circ}\text{C}$ .

Symbol	Parameter	Conditions	Min	Typ	Max	Unit
$t_r$	rise time	at $t = t_1$ : $0 < V_1 \leq 400\text{ mV}$	[1] 0	-	500	ms
$t_{wait}$	wait time		[1][2] 12	-	-	$\mu\text{s}$
$V_1$	input voltage	at $t = t_1$ on pin $V_{DD}$	0	-	400	mV

[1] See [Figure 17](#).

[2] The wait time specifies the time the power supply must be at levels below 400 mV before ramping up.

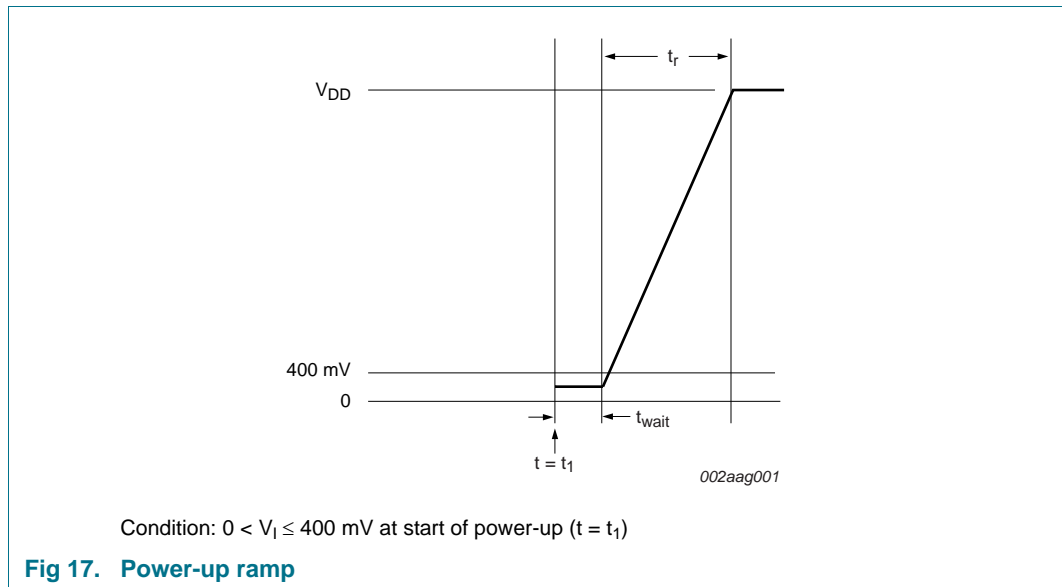

### 10.2 Flash memory

**Table 11. Flash characteristics**

$T_{amb} = -40\text{ }^{\circ}\text{C}$  to  $+85\text{ }^{\circ}\text{C}$ , unless otherwise specified.

Symbol	Parameter	Conditions	Min	Typ	Max	Unit
$N_{endu}$	endurance		[1] 10000	100000	-	cycles
$t_{ret}$	retention time	powered	10	-	-	years
		unpowered	20	-	-	years
$t_{er}$	erase time	sector or multiple consecutive sectors	95	100	105	ms
$t_{prog}$	programming time		[2] 0.95	1	1.05	ms

[1] Number of program/erase cycles.

[2] Programming times are given for writing 256 bytes from RAM to the flash. Data must be written to the flash in blocks of 256 bytes.

### 10.3 External clock

**Table 12. Dynamic characteristic: external clock**

$T_{amb} = -40\text{ }^{\circ}\text{C}$  to  $+85\text{ }^{\circ}\text{C}$ ;  $V_{DD}$  over specified ranges.<sup>[1]</sup>

Symbol	Parameter	Conditions	Min	Typ <sup>[2]</sup>	Max	Unit
$f_{osc}$	oscillator frequency		1	-	25	MHz
$T_{cy(clk)}$	clock cycle time		40	-	1000	ns
$t_{CHCX}$	clock HIGH time		$T_{cy(clk)} \times 0.4$	-	-	ns
$t_{CLCX}$	clock LOW time		$T_{cy(clk)} \times 0.4$	-	-	ns
$t_{CLCH}$	clock rise time		-	-	5	ns
$t_{CHCL}$	clock fall time		-	-	5	ns

[1] Parameters are valid over operating temperature range unless otherwise specified.

[2] Typical ratings are not guaranteed. The values listed are at room temperature (25 °C), nominal supply voltages.

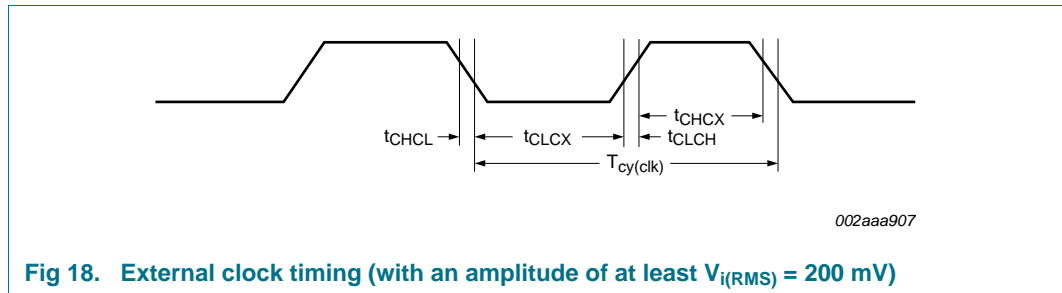

10.4 Internal oscillators

Table 13. Dynamic characteristic: internal oscillators

$T_{amb} = -40\text{ }^{\circ}\text{C}$  to  $+85\text{ }^{\circ}\text{C}$ ;  $2.7\text{ V} \leq V_{DD} \leq 3.6\text{ V}$ .<sup>[1]</sup>

Symbol	Parameter	Conditions	Min	Typ <sup>[2]</sup>	Max	Unit
$f_{osc(RC)}$	internal RC oscillator frequency	-	11.88	12	12.12	MHz

[1] Parameters are valid over operating temperature range unless otherwise specified.

[2] Typical ratings are not guaranteed. The values listed are at room temperature (25 °C), nominal supply voltages.

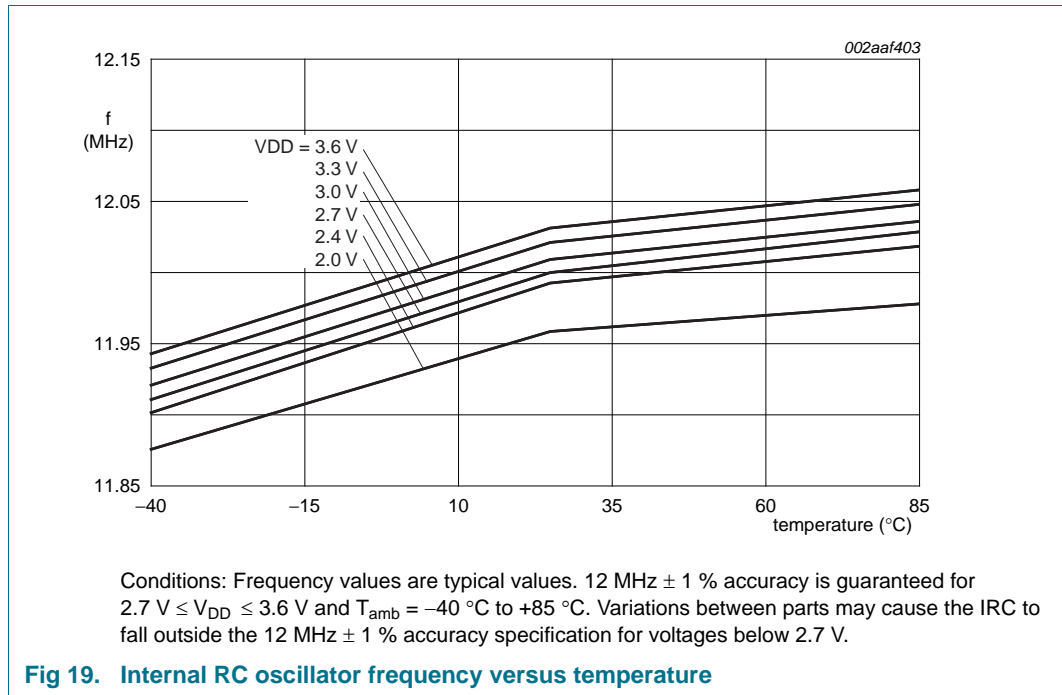

Fig 19. Internal RC oscillator frequency versus temperature

Table 14. Dynamic characteristics: Watchdog oscillator

Symbol	Parameter	Conditions	Min	Typ <sup>[1]</sup>	Max	Unit
$f_{osc(int)}$	internal oscillator frequency	DIVSEL = 0x1F, FREQSEL = 0x1 in the WDTOSCCTRL register;	<sup>[2][3]</sup> -	9.4	-	kHz
		DIVSEL = 0x00, FREQSEL = 0xF in the WDTOSCCTRL register	<sup>[2][3]</sup> -	2300	-	kHz

[1] Typical ratings are not guaranteed. The values listed are at room temperature (25 °C), nominal supply voltages.

[2] The typical frequency spread over processing and temperature (T<sub>amb</sub> = -40 °C to +85 °C) is ±40 %.

[3] See the *LPC111x user manual*.



## 10.5 I/O pins

**Table 15. Dynamic characteristic: I/O pins<sup>[1]</sup>**

$T_{amb} = -40\text{ }^{\circ}\text{C}$  to  $+85\text{ }^{\circ}\text{C}$ ;  $3.0\text{ V} \leq V_{DD} \leq 3.6\text{ V}$ .

Symbol	Parameter	Conditions	Min	Typ	Max	Unit
$t_r$	rise time	pin configured as output	3.0	-	5.0	ns
$t_f$	fall time	pin configured as output	2.5	-	5.0	ns

[1] Applies to standard port pins and  $\overline{\text{RESET}}$  pin.

## 10.6 I<sup>2</sup>C-bus

**Table 16. Dynamic characteristic: I<sup>2</sup>C-bus pins<sup>[1]</sup>**

$T_{amb} = -40\text{ }^{\circ}\text{C}$  to  $+85\text{ }^{\circ}\text{C}$ .<sup>[2]</sup>

Symbol	Parameter	Conditions	Min	Max	Unit
$f_{\text{SCL}}$	SCL clock frequency	Standard-mode	0	100	kHz
		Fast-mode	0	400	kHz
		Fast-mode Plus	0	1	MHz
$t_f$	fall time	<sup>[4][5][6][7]</sup> of both SDA and SCL signals	-	300	ns
		Standard-mode			
		Fast-mode	$20 + 0.1 \times C_b$	300	ns
$t_{\text{LOW}}$	LOW period of the SCL clock	Standard-mode	4.7	-	$\mu\text{s}$
		Fast-mode	1.3	-	$\mu\text{s}$
		Fast-mode Plus	0.5	-	$\mu\text{s}$
$t_{\text{HIGH}}$	HIGH period of the SCL clock	Standard-mode	4.0	-	$\mu\text{s}$
		Fast-mode	0.6	-	$\mu\text{s}$
		Fast-mode Plus	0.26	-	$\mu\text{s}$
$t_{\text{HD;DAT}}$	data hold time	<sup>[3][4][8]</sup> Standard-mode	0	-	$\mu\text{s}$
		Fast-mode	0	-	$\mu\text{s}$
		Fast-mode Plus	0	-	$\mu\text{s}$
$t_{\text{SU;DAT}}$	data set-up time	<sup>[9][10]</sup> Standard-mode	250	-	ns
		Fast-mode	100	-	ns
		Fast-mode Plus	50	-	ns

[1] See the I<sup>2</sup>C-bus specification *UM10204* for details.

[2] Parameters are valid over operating temperature range unless otherwise specified.

[3]  $t_{\text{HD;DAT}}$  is the data hold time that is measured from the falling edge of SCL; applies to data in transmission and the acknowledge.

[4] A device must internally provide a hold time of at least 300 ns for the SDA signal (with respect to the  $V_{\text{IH(min)}}$  of the SCL signal) to bridge the undefined region of the falling edge of SCL.

[5]  $C_b$  = total capacitance of one bus line in pF.

- [6] The maximum  $t_f$  for the SDA and SCL bus lines is specified at 300 ns. The maximum fall time for the SDA output stage  $t_f$  is specified at 250 ns. This allows series protection resistors to be connected in between the SDA and the SCL pins and the SDA/SCL bus lines without exceeding the maximum specified  $t_f$ .
- [7] In Fast-mode Plus, fall time is specified the same for both output stage and bus timing. If series resistors are used, designers should allow for this when considering bus timing.
- [8] The maximum  $t_{HD;DAT}$  could be 3.45  $\mu$ s and 0.9  $\mu$ s for Standard-mode and Fast-mode but must be less than the maximum of  $t_{VD;DAT}$  or  $t_{VD;ACK}$  by a transition time (see *UM10204*). This maximum must only be met if the device does not stretch the LOW period ( $t_{LOW}$ ) of the SCL signal. If the clock stretches the SCL, the data must be valid by the set-up time before it releases the clock.
- [9]  $t_{SU;DAT}$  is the data set-up time that is measured with respect to the rising edge of SCL; applies to data in transmission and the acknowledge.
- [10] A Fast-mode I<sup>2</sup>C-bus device can be used in a Standard-mode I<sup>2</sup>C-bus system but the requirement  $t_{SU;DAT} = 250$  ns must then be met. This will automatically be the case if the device does not stretch the LOW period of the SCL signal. If such a device does stretch the LOW period of the SCL signal, it must output the next data bit to the SDA line  $t_{r(max)} + t_{SU;DAT} = 1000 + 250 = 1250$  ns (according to the Standard-mode I<sup>2</sup>C-bus specification) before the SCL line is released. Also the acknowledge timing must meet this set-up time.

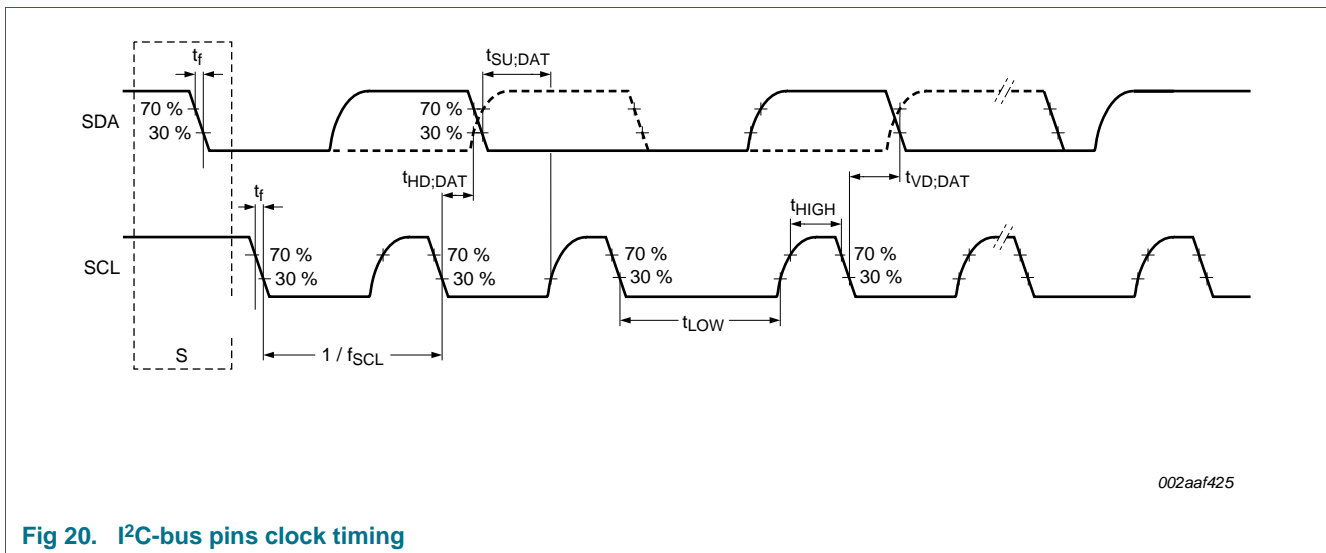

Fig 20. I<sup>2</sup>C-bus pins clock timing

## 10.7 SPI interfaces

Table 17. Dynamic characteristics of SPI pins in SPI mode

Symbol	Parameter	Conditions	Min	Typ	Max	Unit
<b>SPI master (in SPI mode)</b>						
$T_{cy}(clk)$	clock cycle time	full-duplex mode [1]	50	-	-	ns
		when only transmitting [1]	40	-	-	ns
$t_{DS}$	data set-up time	in SPI mode [2]	15	-	-	ns
		$2.4\text{ V} \leq V_{DD} \leq 3.6\text{ V}$				
		$2.0\text{ V} \leq V_{DD} < 2.4\text{ V}$ [2]	20			ns
		$1.8\text{ V} \leq V_{DD} < 2.0\text{ V}$ [2]	24	-	-	ns
$t_{DH}$	data hold time	in SPI mode [2]	0	-	-	ns
$t_{v(Q)}$	data output valid time	in SPI mode [2]	-	-	10	ns
$t_{h(Q)}$	data output hold time	in SPI mode [2]	0	-	-	ns

Table 17. Dynamic characteristics of SPI pins in SPI mode

Symbol	Parameter	Conditions	Min	Typ	Max	Unit
<b>SPI slave (in SPI mode)</b>						
$T_{cy(PCLK)}$	PCLK cycle time		20	-	-	ns
$t_{DS}$	data set-up time	in SPI mode	[3][4] 0	-	-	ns
$t_{DH}$	data hold time	in SPI mode	[3][4] $3 \times T_{cy(PCLK)} + 4$	-	-	ns
$t_{v(Q)}$	data output valid time	in SPI mode	[3][4] -	-	$3 \times T_{cy(PCLK)} + 11$	ns
$t_{h(Q)}$	data output hold time	in SPI mode	[3][4] -	-	$2 \times T_{cy(PCLK)} + 5$	ns

- [1]  $T_{cy(clk)} = (SSPCLKDIV \times (1 + SCR) \times CPSDVSR) / f_{main}$ . The clock cycle time derived from the SPI bit rate  $T_{cy(clk)}$  is a function of the main clock frequency  $f_{main}$ , the SPI peripheral clock divider (SSPCLKDIV), the SPI SCR parameter (specified in the SSP0CR0 register), and the SPI CPSDVSR parameter (specified in the SPI clock prescale register).
- [2]  $T_{amb} = -40\text{ }^{\circ}\text{C}$  to  $+85\text{ }^{\circ}\text{C}$ .
- [3]  $T_{cy(clk)} = 12 \times T_{cy(PCLK)}$ .
- [4]  $T_{amb} = 25\text{ }^{\circ}\text{C}$ ; for normal voltage supply range:  $V_{DD} = 3.3\text{ V}$ .

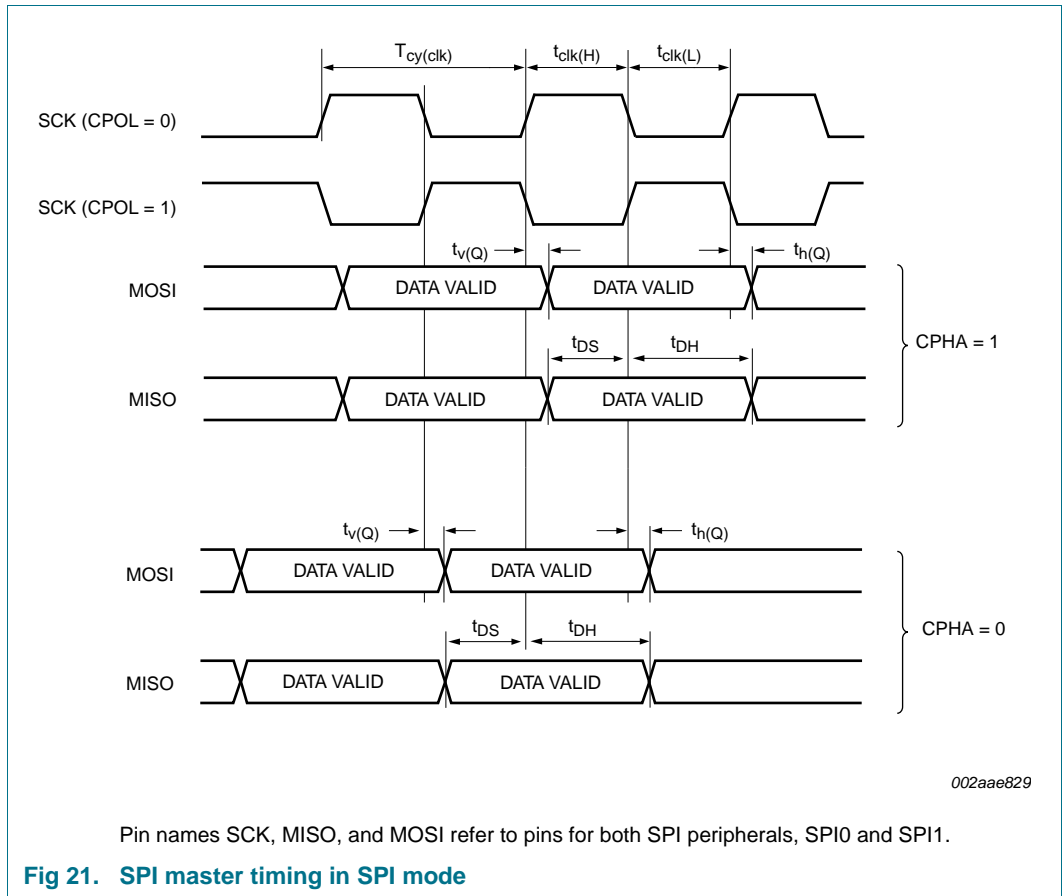

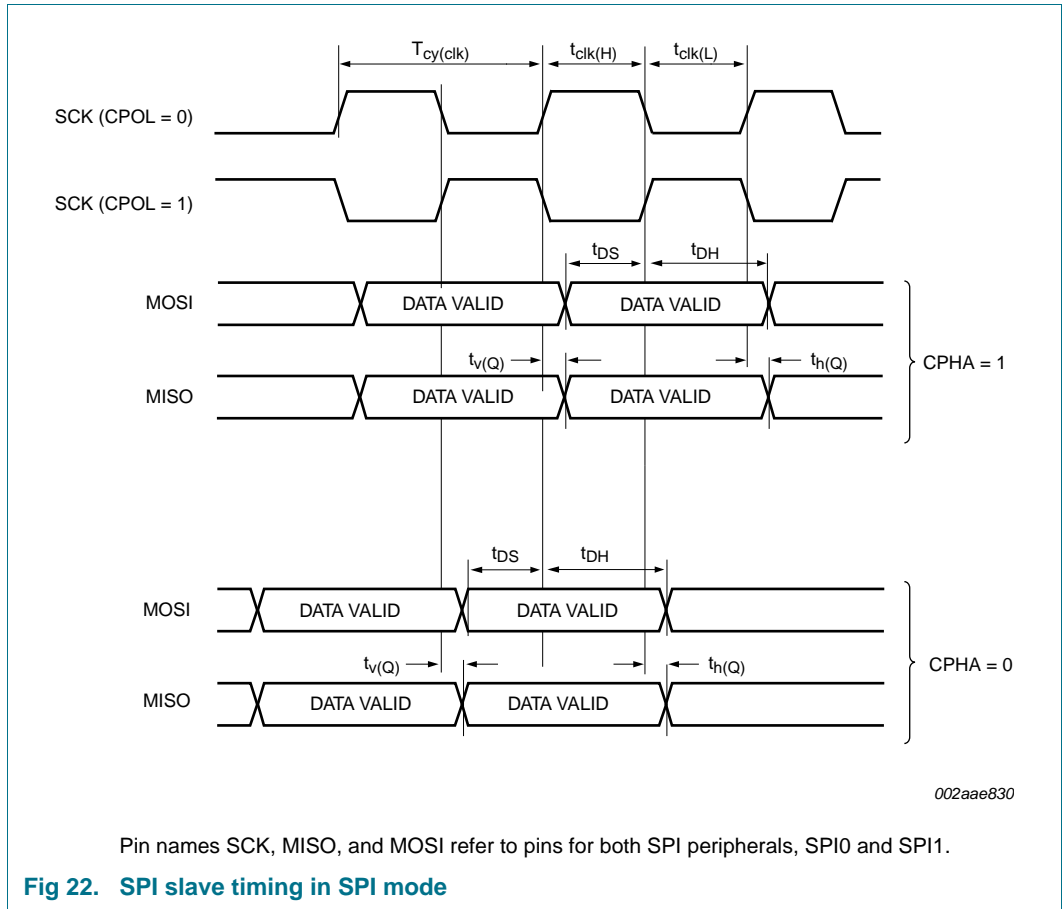

## 11. Application information

### 11.1 ADC usage notes

The following guidelines show how to increase the performance of the ADC in a noisy environment beyond the ADC specifications listed in [Table 7](#):

- The ADC input trace must be short and as close as possible to the LPC11D14 chip.
- The ADC input traces must be shielded from fast switching digital signals and noisy power supply lines.
- Because the ADC and the digital core share the same power supply, the power supply line must be adequately filtered.
- To improve the ADC performance in a very noisy environment, put the device in Sleep mode during the ADC conversion.

### 11.2 XTAL input

The input voltage to the on-chip oscillators is limited to 1.8 V. If the oscillator is driven by a clock in slave mode, it is recommended that the input be coupled through a capacitor with  $C_i = 100$  pF. To limit the input voltage to the specified range, choose an additional capacitor to ground  $C_g$  which attenuates the input voltage by a factor  $C_i / (C_i + C_g)$ . In slave mode, a minimum of 200 mV (RMS) is needed.

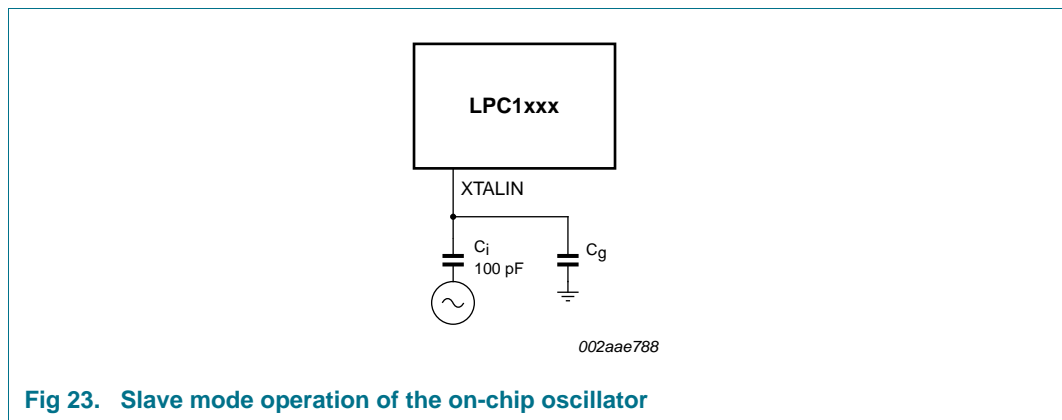

**Fig 23. Slave mode operation of the on-chip oscillator**

In slave mode the input clock signal should be coupled by means of a capacitor of 100 pF ([Figure 23](#)), with an amplitude between 200 mV (RMS) and 1000 mV (RMS). This corresponds to a square wave signal with a signal swing of between 280 mV and 1.4 V. The XTALOUT pin in this configuration can be left unconnected.

External components and models used in oscillation mode are shown in [Figure 24](#) and in [Table 18](#) and [Table 19](#). Since the feedback resistance is integrated on chip, only a crystal and the capacitances  $C_{X1}$  and  $C_{X2}$  need to be connected externally in case of fundamental mode oscillation (the fundamental frequency is represented by  $L$ ,  $C_L$  and  $R_S$ ). Capacitance  $C_P$  in [Figure 24](#) represents the parallel package capacitance and should not be larger than 7 pF. Parameters  $F_{OSC}$ ,  $C_L$ ,  $R_S$  and  $C_P$  are supplied by the crystal manufacturer (see [Table 18](#)).

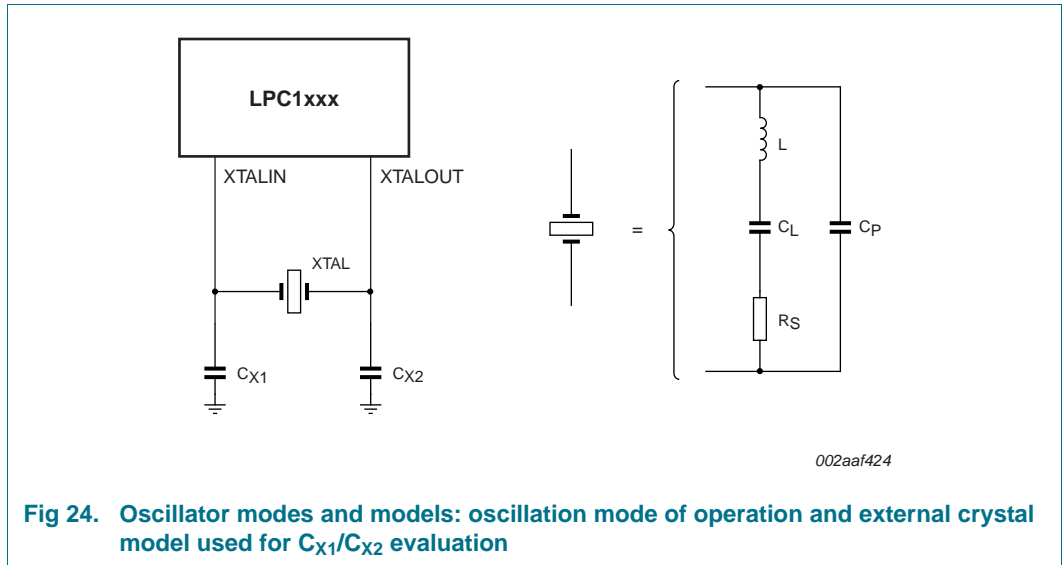

**Table 18. Recommended values for  $C_{X1}/C_{X2}$  in oscillation mode (crystal and external components parameters) low frequency mode**

Fundamental oscillation frequency $F_{osc}$	Crystal load capacitance $C_L$	Maximum crystal series resistance $R_S$	External load capacitors $C_{X1}, C_{X2}$
1 MHz - 5 MHz	10 pF	< 300 $\Omega$	18 pF, 18 pF
	20 pF	< 300 $\Omega$	39 pF, 39 pF
	30 pF	< 300 $\Omega$	57 pF, 57 pF
5 MHz - 10 MHz	10 pF	< 300 $\Omega$	18 pF, 18 pF
	20 pF	< 200 $\Omega$	39 pF, 39 pF
	30 pF	< 100 $\Omega$	57 pF, 57 pF
10 MHz - 15 MHz	10 pF	< 160 $\Omega$	18 pF, 18 pF
	20 pF	< 60 $\Omega$	39 pF, 39 pF
15 MHz - 20 MHz	10 pF	< 80 $\Omega$	18 pF, 18 pF

**Table 19. Recommended values for  $C_{X1}/C_{X2}$  in oscillation mode (crystal and external components parameters) high frequency mode**

Fundamental oscillation frequency $F_{osc}$	Crystal load capacitance $C_L$	Maximum crystal series resistance $R_S$	External load capacitors $C_{X1}, C_{X2}$
15 MHz - 20 MHz	10 pF	< 180 $\Omega$	18 pF, 18 pF
	20 pF	< 100 $\Omega$	39 pF, 39 pF
20 MHz - 25 MHz	10 pF	< 160 $\Omega$	18 pF, 18 pF
	20 pF	< 80 $\Omega$	39 pF, 39 pF

### 11.3 XTAL Printed Circuit Board (PCB) layout guidelines

The crystal should be connected on the PCB as close as possible to the oscillator input and output pins of the chip. Take care that the load capacitors  $C_{X1}$ ,  $C_{X2}$ , and  $C_{X3}$  in case of third overtone crystal usage have a common ground plane. The external components must also be connected to the ground plain. Loops must be made as small as possible in

order to keep the noise coupled in via the PCB as small as possible. Also parasitics should stay as small as possible. Values of  $C_{X1}$  and  $C_{X2}$  should be chosen smaller accordingly to the increase in parasitics of the PCB layout.

### 11.4 Standard I/O pad configuration

Figure 25 shows the possible pin modes for standard I/O pins with analog input function:

- Digital output driver
- Digital input: Pull-up enabled/disabled
- Digital input: Pull-down enabled/disabled
- Digital input: Repeater mode enabled/disabled
- Analog input

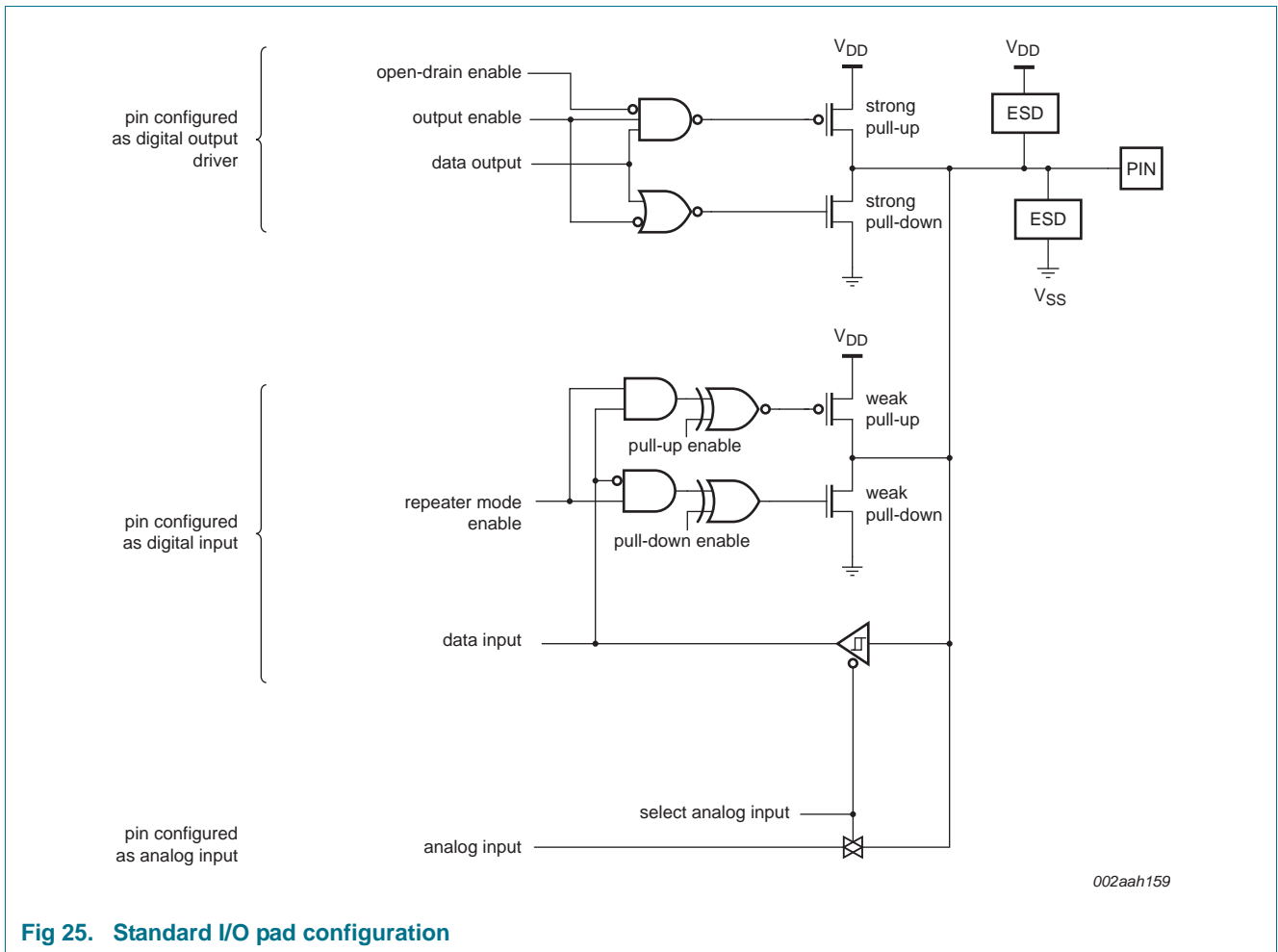

Fig 25. Standard I/O pad configuration

### 11.5 Reset pad configuration

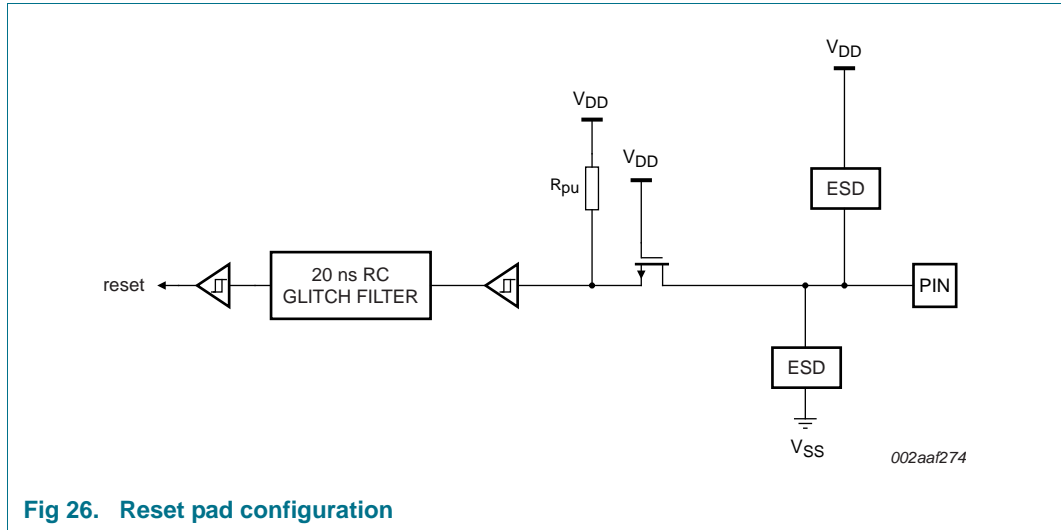

Fig 26. Reset pad configuration

### 11.6 ElectroMagnetic Compatibility (EMC)

Radiated emission measurements according to the IEC 61967-2 standard using the TEM-cell method are shown for the LPC1114FBD48/302 in [Table 20](#).

**Table 20. ElectroMagnetic Compatibility (EMC) for part LPC1114FBD48/302 (TEM-cell method)**

$V_{DD} = 3.3\text{ V}$ ;  $T_{amb} = 25\text{ °C}$ .

Parameter	Frequency band	System clock =			Unit
		12 MHz	24 MHz	48 MHz	
<b>Input clock: IRC (12 MHz)</b>					
maximum peak level	150 kHz - 30 MHz	-7	-5	-7	dB $\mu$ V
	30 MHz - 150 MHz	-2	1	10	dB $\mu$ V
	150 MHz - 1 GHz	4	8	16	dB $\mu$ V
IEC level <sup>[1]</sup>	-	O	N	M	-
<b>Input clock: crystal oscillator (12 MHz)</b>					
maximum peak level	150 kHz - 30 MHz	-7	-7	-7	dB $\mu$ V
	30 MHz - 150 MHz	-2	1	8	dB $\mu$ V
	150 MHz - 1 GHz	4	7	14	dB $\mu$ V
IEC level <sup>[1]</sup>	-	O	N	M	-

[1] IEC levels refer to Appendix D in the IEC 61967-2 Specification.



## 12. Package outline

LQFP100: plastic low profile quad flat package; 100 leads; body 14 x 14 x 1.4 mm

SOT407-1

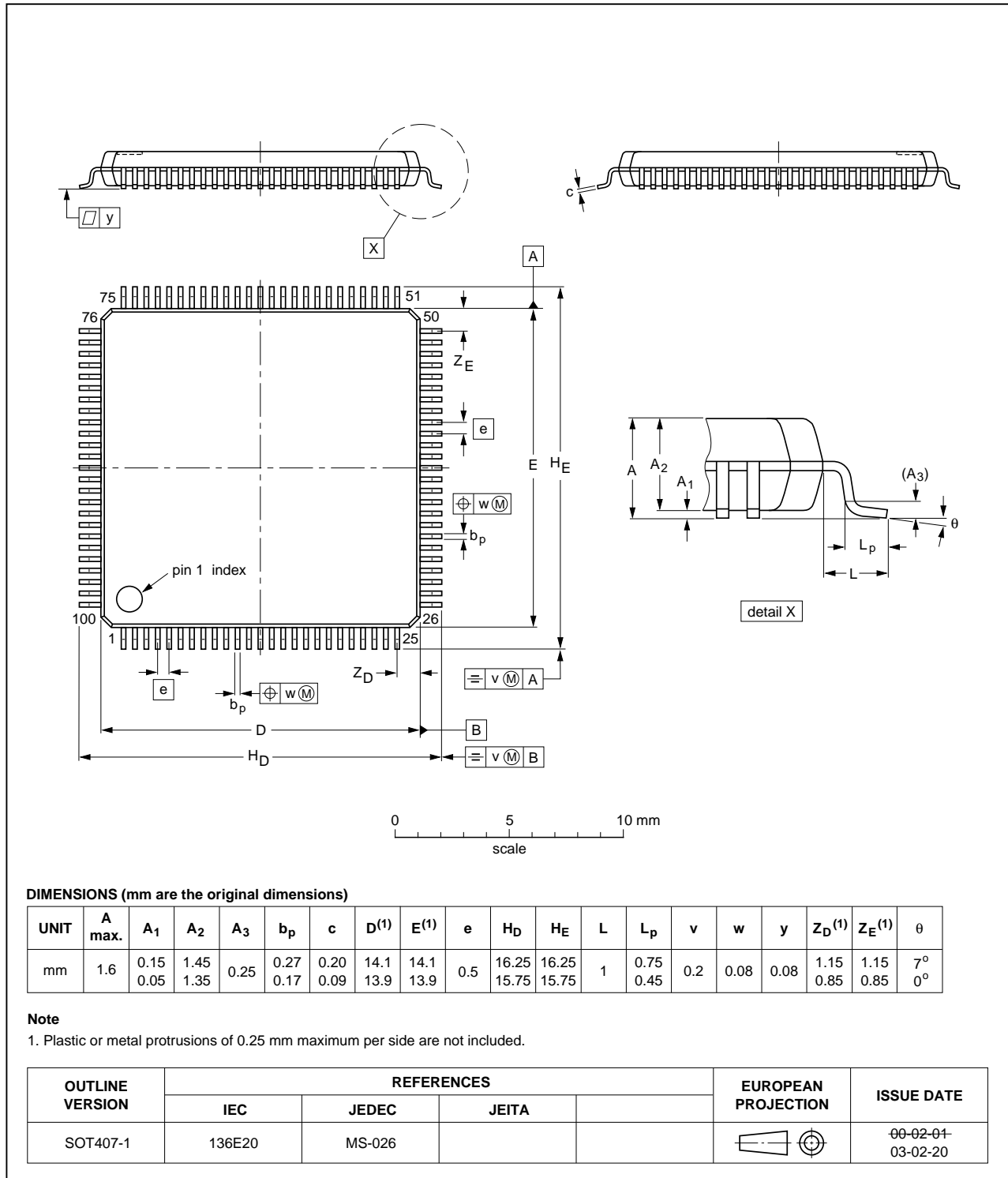

Fig 27. Package outline (LQFP100)

13. Soldering

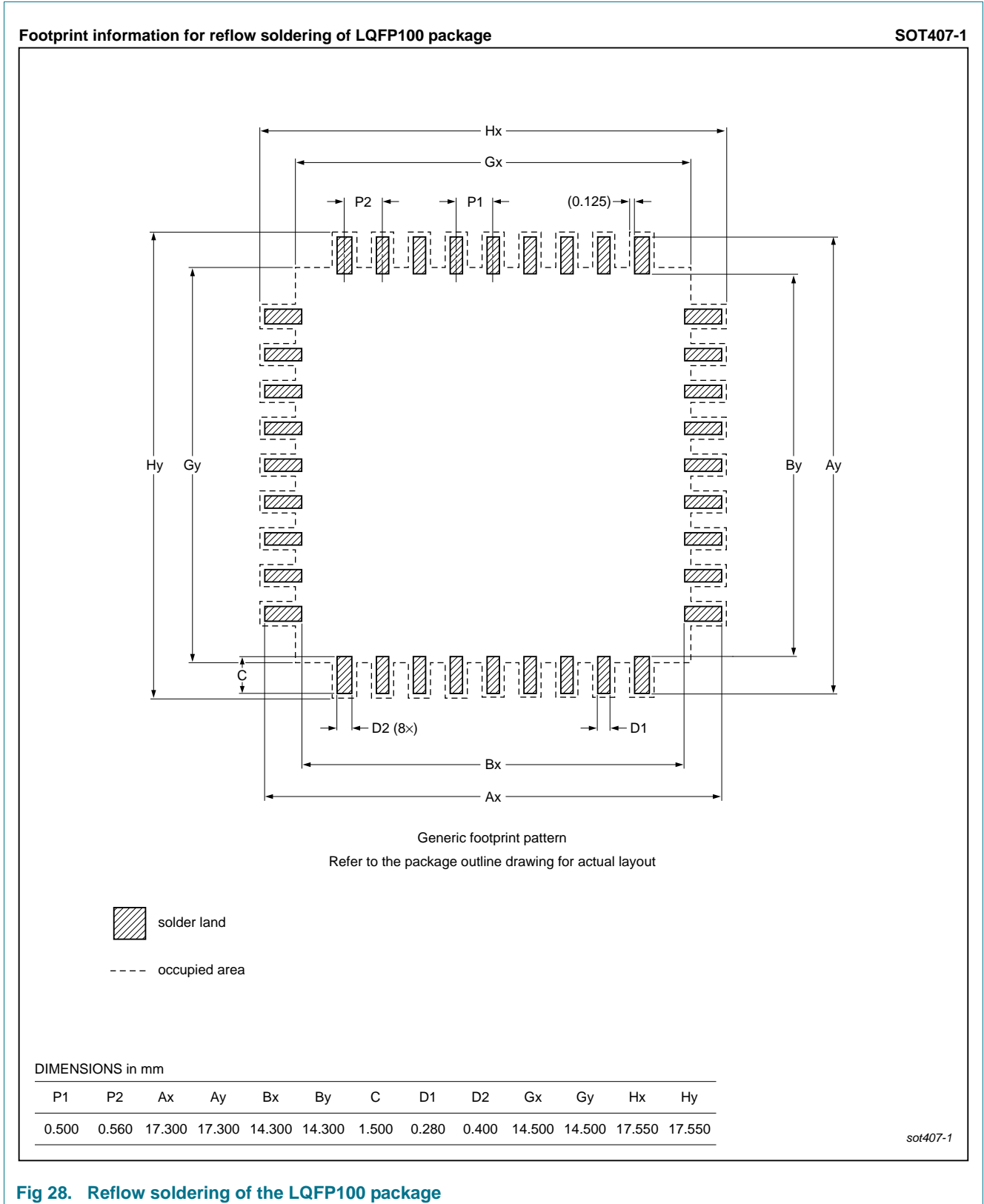

Fig 28. Reflow soldering of the LQFP100 package

## 14. Abbreviations

Table 21. Abbreviations

Acronym	Description
ADC	Analog-to-Digital Converter
AHB	Advanced High-performance Bus
APB	Advanced Peripheral Bus
BOD	BrownOut Detection
GPIO	General Purpose Input/Output
PLL	Phase-Locked Loop
RC	Resistor-Capacitor
SPI	Serial Peripheral Interface
SSI	Serial Synchronous Interface
SSP	Synchronous Serial Port
TEM	Transverse ElectroMagnetic
UART	Universal Asynchronous Receiver/Transmitter

## 15. References

- [1] LPC1111/12/13/14 Data sheet
- [2] PCF8576D Data sheet

## 16. Revision history

Table 22. Revision history

Document ID	Release date	Data sheet status	Change notice	Supersedes
LPC11D14 v.2	20120723	Product data sheet	-	LPC11D14 v.1
Modifications:	<ul style="list-style-type: none"> <li>• <a href="#">Figure 3</a> updated.</li> <li>• Internal oscillator description updated (<a href="#">Section 7.2.5</a>).</li> <li>• Description of the <math>V_{SS(LCD)}</math> pin updated in <a href="#">Table 3</a>.</li> <li>• Data sheet status changed to Product data sheet.</li> <li>• Remove table note “The peak current is limited to 25 times the corresponding maximum current” in <a href="#">Table 5</a>.</li> <li>• For parameters <math>I_{OL}</math>, <math>V_{OL}</math>, <math>I_{OH}</math>, <math>V_{OH}</math>, changed conditions to <math>1.8\text{ V} \leq V_{DD} &lt; 2.5\text{ V}</math> and <math>2.5\text{ V} \leq V_{DD} \leq 3.6\text{ V}</math> in <a href="#">Table 6</a>.</li> <li>• <a href="#">Figure 25</a> updated for parts with configurable open-drain mode.</li> <li>• WDOSc frequency range corrected.</li> </ul>			
LPC11D14 v.1	20110928	Preliminary data sheet	-	-

## 17. Legal information

### 17.1 Data sheet status

Document status <sup>[1][2]</sup>	Product status <sup>[3]</sup>	Definition
Objective [short] data sheet	Development	This document contains data from the objective specification for product development.
Preliminary [short] data sheet	Qualification	This document contains data from the preliminary specification.
Product [short] data sheet	Production	This document contains the product specification.

[1] Please consult the most recently issued document before initiating or completing a design.

[2] The term 'short data sheet' is explained in section "Definitions".

[3] The product status of device(s) described in this document may have changed since this document was published and may differ in case of multiple devices. The latest product status information is available on the Internet at URL <http://www.nxp.com>.

### 17.2 Definitions

**Draft** — The document is a draft version only. The content is still under internal review and subject to formal approval, which may result in modifications or additions. NXP Semiconductors does not give any representations or warranties as to the accuracy or completeness of information included herein and shall have no liability for the consequences of use of such information.

**Short data sheet** — A short data sheet is an extract from a full data sheet with the same product type number(s) and title. A short data sheet is intended for quick reference only and should not be relied upon to contain detailed and full information. For detailed and full information see the relevant full data sheet, which is available on request via the local NXP Semiconductors sales office. In case of any inconsistency or conflict with the short data sheet, the full data sheet shall prevail.

**Product specification** — The information and data provided in a Product data sheet shall define the specification of the product as agreed between NXP Semiconductors and its customer, unless NXP Semiconductors and customer have explicitly agreed otherwise in writing. In no event however, shall an agreement be valid in which the NXP Semiconductors product is deemed to offer functions and qualities beyond those described in the Product data sheet.

### 17.3 Disclaimers

**Limited warranty and liability** — Information in this document is believed to be accurate and reliable. However, NXP Semiconductors does not give any representations or warranties, expressed or implied, as to the accuracy or completeness of such information and shall have no liability for the consequences of use of such information. NXP Semiconductors takes no responsibility for the content in this document if provided by an information source outside of NXP Semiconductors.

In no event shall NXP Semiconductors be liable for any indirect, incidental, punitive, special or consequential damages (including - without limitation - lost profits, lost savings, business interruption, costs related to the removal or replacement of any products or rework charges) whether or not such damages are based on tort (including negligence), warranty, breach of contract or any other legal theory.

Notwithstanding any damages that customer might incur for any reason whatsoever, NXP Semiconductors' aggregate and cumulative liability towards customer for the products described herein shall be limited in accordance with the *Terms and conditions of commercial sale* of NXP Semiconductors.

**Right to make changes** — NXP Semiconductors reserves the right to make changes to information published in this document, including without limitation specifications and product descriptions, at any time and without notice. This document supersedes and replaces all information supplied prior to the publication hereof.

**Suitability for use** — NXP Semiconductors products are not designed, authorized or warranted to be suitable for use in life support, life-critical or safety-critical systems or equipment, nor in applications where failure or malfunction of an NXP Semiconductors product can reasonably be expected to result in personal injury, death or severe property or environmental damage. NXP Semiconductors and its suppliers accept no liability for inclusion and/or use of NXP Semiconductors products in such equipment or applications and therefore such inclusion and/or use is at the customer's own risk.

**Applications** — Applications that are described herein for any of these products are for illustrative purposes only. NXP Semiconductors makes no representation or warranty that such applications will be suitable for the specified use without further testing or modification.

Customers are responsible for the design and operation of their applications and products using NXP Semiconductors products, and NXP Semiconductors accepts no liability for any assistance with applications or customer product design. It is customer's sole responsibility to determine whether the NXP Semiconductors product is suitable and fit for the customer's applications and products planned, as well as for the planned application and use of customer's third party customer(s). Customers should provide appropriate design and operating safeguards to minimize the risks associated with their applications and products.

NXP Semiconductors does not accept any liability related to any default, damage, costs or problem which is based on any weakness or default in the customer's applications or products, or the application or use by customer's third party customer(s). Customer is responsible for doing all necessary testing for the customer's applications and products using NXP Semiconductors products in order to avoid a default of the applications and the products or of the application or use by customer's third party customer(s). NXP does not accept any liability in this respect.

**Limiting values** — Stress above one or more limiting values (as defined in the Absolute Maximum Ratings System of IEC 60134) will cause permanent damage to the device. Limiting values are stress ratings only and (proper) operation of the device at these or any other conditions above those given in the Recommended operating conditions section (if present) or the Characteristics sections of this document is not warranted. Constant or repeated exposure to limiting values will permanently and irreversibly affect the quality and reliability of the device.

**Terms and conditions of commercial sale** — NXP Semiconductors products are sold subject to the general terms and conditions of commercial sale, as published at <http://www.nxp.com/profile/terms>, unless otherwise agreed in a valid written individual agreement. In case an individual agreement is concluded only the terms and conditions of the respective agreement shall apply. NXP Semiconductors hereby expressly objects to applying the customer's general terms and conditions with regard to the purchase of NXP Semiconductors products by customer.

**No offer to sell or license** — Nothing in this document may be interpreted or construed as an offer to sell products that is open for acceptance or the grant, conveyance or implication of any license under any copyrights, patents or other industrial or intellectual property rights.

**Export control** — This document as well as the item(s) described herein may be subject to export control regulations. Export might require a prior authorization from competent authorities.

**Non-automotive qualified products** — Unless this data sheet expressly states that this specific NXP Semiconductors product is automotive qualified, the product is not suitable for automotive use. It is neither qualified nor tested in accordance with automotive testing or application requirements. NXP Semiconductors accepts no liability for inclusion and/or use of non-automotive qualified products in automotive equipment or applications.

In the event that customer uses the product for design-in and use in automotive applications to automotive specifications and standards, customer (a) shall use the product without NXP Semiconductors' warranty of the product for such automotive applications, use and specifications, and (b)

whenever customer uses the product for automotive applications beyond NXP Semiconductors' specifications such use shall be solely at customer's own risk, and (c) customer fully indemnifies NXP Semiconductors for any liability, damages or failed product claims resulting from customer design and use of the product for automotive applications beyond NXP Semiconductors' standard warranty and NXP Semiconductors' product specifications.

## 17.4 Trademarks

Notice: All referenced brands, product names, service names and trademarks are the property of their respective owners.

**I<sup>2</sup>C-bus** — logo is a trademark of NXP B.V.

## 18. Contact information

For more information, please visit: <http://www.nxp.com>

For sales office addresses, please send an email to: [salesaddresses@nxp.com](mailto:salesaddresses@nxp.com)

19. Contents

<b>1</b>	<b>General description</b> . . . . .	<b>1</b>	<b>12</b>	<b>Package outline</b> . . . . .	<b>41</b>
<b>2</b>	<b>Features and benefits</b> . . . . .	<b>1</b>	<b>13</b>	<b>Soldering</b> . . . . .	<b>42</b>
<b>3</b>	<b>Applications</b> . . . . .	<b>3</b>	<b>14</b>	<b>Abbreviations</b> . . . . .	<b>43</b>
<b>4</b>	<b>Ordering information</b> . . . . .	<b>3</b>	<b>15</b>	<b>References</b> . . . . .	<b>43</b>
4.1	Ordering options . . . . .	3	<b>16</b>	<b>Revision history</b> . . . . .	<b>44</b>
<b>5</b>	<b>Block diagram</b> . . . . .	<b>3</b>	<b>17</b>	<b>Legal information</b> . . . . .	<b>45</b>
<b>6</b>	<b>Pinning information</b> . . . . .	<b>6</b>	17.1	Data sheet status . . . . .	45
6.1	Pinning . . . . .	6	17.2	Definitions . . . . .	45
6.2	Pin description . . . . .	7	17.3	Disclaimers . . . . .	45
<b>7</b>	<b>Functional description</b> . . . . .	<b>13</b>	17.4	Trademarks . . . . .	46
7.1	LPC1114 microcontroller . . . . .	13	<b>18</b>	<b>Contact information</b> . . . . .	<b>46</b>
7.2	LCD driver . . . . .	13	<b>19</b>	<b>Contents</b> . . . . .	<b>47</b>
7.2.1	General description . . . . .	13			
7.2.2	Functional description . . . . .	13			
7.2.3	Reset state of the LCD controller and pins . . . . .	13			
7.2.4	LCD bias generator . . . . .	14			
7.2.5	Oscillator . . . . .	14			
7.2.5.1	Internal clock . . . . .	14			
7.2.6	Timing . . . . .	14			
7.2.7	Display register . . . . .	14			
7.2.8	Segment outputs . . . . .	14			
7.2.9	Backplane outputs . . . . .	14			
7.2.10	Display RAM . . . . .	15			
<b>8</b>	<b>Limiting values</b> . . . . .	<b>16</b>			
<b>9</b>	<b>Static characteristics</b> . . . . .	<b>17</b>			
9.1	BOD static characteristics . . . . .	22			
9.2	Power consumption . . . . .	22			
9.3	Peripheral power consumption . . . . .	26			
9.4	Electrical pin characteristics . . . . .	27			
<b>10</b>	<b>Dynamic characteristics</b> . . . . .	<b>30</b>			
10.1	Power-up ramp conditions . . . . .	30			
10.2	Flash memory . . . . .	30			
10.3	External clock . . . . .	31			
10.4	Internal oscillators . . . . .	32			
10.5	I/O pins . . . . .	33			
10.6	I <sup>2</sup> C-bus . . . . .	33			
10.7	SPI interfaces . . . . .	34			
<b>11</b>	<b>Application information</b> . . . . .	<b>37</b>			
11.1	ADC usage notes . . . . .	37			
11.2	XTAL input . . . . .	37			
11.3	XTAL Printed Circuit Board (PCB) layout guidelines . . . . .	38			
11.4	Standard I/O pad configuration . . . . .	39			
11.5	Reset pad configuration . . . . .	40			
11.6	ElectroMagnetic Compatibility (EMC) . . . . .	40			

Please be aware that important notices concerning this document and the product(s) described herein, have been included in section 'Legal information'.

© NXP B.V. 2012. All rights reserved.

For more information, please visit: <http://www.nxp.com>  
 For sales office addresses, please send an email to: [salesaddresses@nxp.com](mailto:salesaddresses@nxp.com)

Date of release: 23 July 2012  
 Document identifier: LPC11D14