

AC Controller Modules

$I_{RMS} = 175\text{ A}$
 $V_{RRM} = 800\text{-}1600\text{ V}$

Preliminary Data

V_{RSM} V_{DSM} V	V_{RRM} V_{DRM} V	Type	
800	800	MMO 175-08io7	MLO 175-08io7
1200	1200	MMO 175-12io7	MLO 175-12io7
1600	1600	MMO 175-16io7	MLO 175-16io7

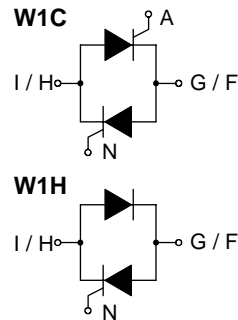

Symbol	Conditions	Maximum Ratings		
I_{RMS}	$T_C = 85^\circ\text{C}$, 50 - 400 Hz, (per single controller)	175	A	
I_{TRMS}		125	A	
I_{TAVM}	$T_C = 85^\circ\text{C}$; 180° sine	80	A	
I_{TSM}	$T_{VJ} = 45^\circ\text{C}$ $V_R = 0$	t = 10 ms (50 Hz), sine t = 8.3 ms (60 Hz), sine	1500 1600	A A
	$T_{VJ} = 125^\circ\text{C}$ $V_R = 0$	t = 10 ms (50 Hz), sine t = 8.3 ms (60 Hz), sine	1350 1450	A A
I^2t	$T_{VJ} = 45^\circ\text{C}$ $V_R = 0$	t = 10 ms (50 Hz), sine t = 8.3 ms (60 Hz), sine	11200 10750	A^2s A^2s
	$T_{VJ} = 125^\circ\text{C}$ $V_R = 0$	t = 10 ms (50 Hz), sine t = 8.3 ms (60 Hz), sine	9100 8830	A^2s A^2s
$(di/dt)_{cr}$	$T_{VJ} = 125^\circ\text{C}$ f = 50 Hz, $t_p = 200\ \mu\text{s}$ $V_D = \frac{2}{3} V_{DRM}$ $I_G = 0.45\text{ A}$ $di_G/dt = 0.45\text{ A}/\mu\text{s}$	repetitive, $I_T = 80\text{ A}$	150	$\text{A}/\mu\text{s}$
		non repetitive, $I_T = I_{TAVM}$	500	$\text{A}/\mu\text{s}$
$(dv/dt)_{cr}$	$T_{VJ} = 125^\circ\text{C}$; $V_{DR} = \frac{2}{3} V_{DRM}$ $R_{GK} = \infty$; method 1 (linear voltage rise)		1000	$\text{V}/\mu\text{s}$
P_{GM}	$T_{VJ} = 125^\circ\text{C}$	$t_p = 30\ \mu\text{s}$	10	W
	$I_T = I_{TAVM}$	$t_p = 300\ \mu\text{s}$	5	W
P_{GAVM}			0.5	W
V_{RGM}			10	V
T_{VJ}			-40...+150	$^\circ\text{C}$
T_{VJM}			150	$^\circ\text{C}$
T_{stg}			-40...+125	$^\circ\text{C}$
V_{ISOL}	50/60 Hz, RMS	t = 1 min	2500	V~
	$I_{ISOL} \leq 1\text{ mA}$	t = 1 s	3000	V~
M_d	Mounting torque (M4)		1.5...2.0/14...18	Nm/lb.in.
Weight	typ.		18	g

Features

- Thyristor controller for AC (circuit W1C acc. to IEC) for mains frequency
- Isolation voltage 3000 V~
- Planar glass passivated chips
- Low forward voltage drop
- Lead suitable for PC board solering

Applications

- Switching and control of single and three phase AC circuits
- Light and temperature control
- Softstart AC motor controller
- Solid state switches

Advantages

- Easy to mount with two screws
- Space and weight savings
- Improved temperature and power cycling
- High power density
- Small and light weight

Data according to IEC 60747 and to a single thyristor/diode unless otherwise stated.

Symbol	Conditions	Characteristic Values	
I_D, I_R	$T_{VJ} = 125^\circ\text{C}; V_R = V_{RRM}; V_D = V_{DRM}$	\leq	5 mA
V_T	$I_T = 200 \text{ A}; T_{VJ} = 25^\circ\text{C}$	\leq	1.57 V
V_{T0}	For power-loss calculations only		0.85 V
r_T			3.7 m Ω
V_{GT}	$V_D = 6 \text{ V}$	$T_{VJ} = 25^\circ\text{C}$ $T_{VJ} = -40^\circ\text{C}$	\leq 1.5 V \leq 1.6 V
I_{GT}	$V_D = 6 \text{ V}$	$T_{VJ} = 25^\circ\text{C}$ $T_{VJ} = -40^\circ\text{C}$	\leq 100 mA \leq 200 mA
V_{GD}	$T_{VJ} = 125^\circ\text{C}; V_D = \frac{2}{3} V_{DRM}$	\leq	0.2 V
I_{GD}		\leq	10 mA
I_L	$T_{VJ} = 25^\circ\text{C}; t_p = 10 \mu\text{s}$ $I_G = 0.45 \text{ A}; di_G/dt = 0.45 \text{ A}/\mu\text{s}$	\leq	450 mA
I_H	$T_{VJ} = 25^\circ\text{C}; V_D = 6 \text{ V}; R_{GK} = \infty$	\leq	200 mA
t_{gd}	$T_{VJ} = 25^\circ\text{C}; V_D = \frac{1}{2} V_{DRM}$ $I_G = 0.45 \text{ A}; di_G/dt = 0.45 \text{ A}/\mu\text{s}$	\leq	2 μs
R_{thJC}	per thyristor; DC per module	0.5 0.25	K/W K/W
R_{thCH}	per thyristor; sine 180° el per module	typ. typ.	0.12 0.06 K/W K/W
d_s	Creeping distance on surface		11.2 mm
d_A	Creepage distance in air		17.0 mm
a	Max. allowable acceleration		50 m/s ²

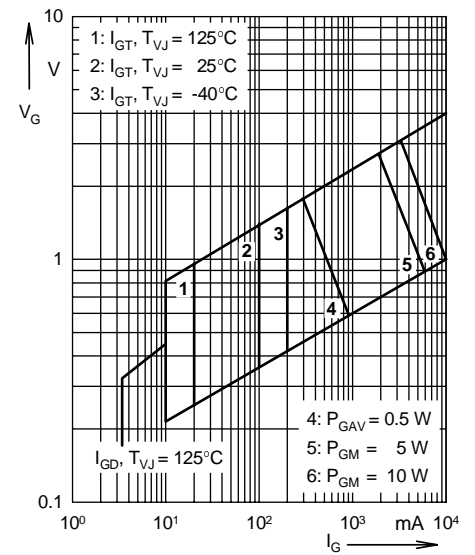

Fig. 1 Gate trigger characteristics

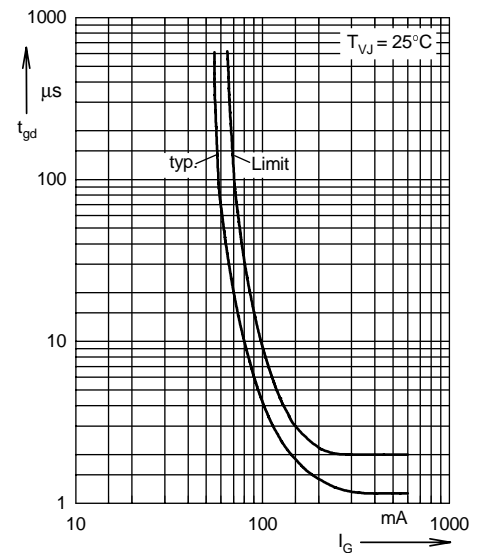

Fig. 2 Gate trigger delay time

Dimensions in mm (1 mm = 0.0394")
