

# 234-100-H5 Solder Mount Hermetic Receptacle MIL-DTL-38999 Series IV Type

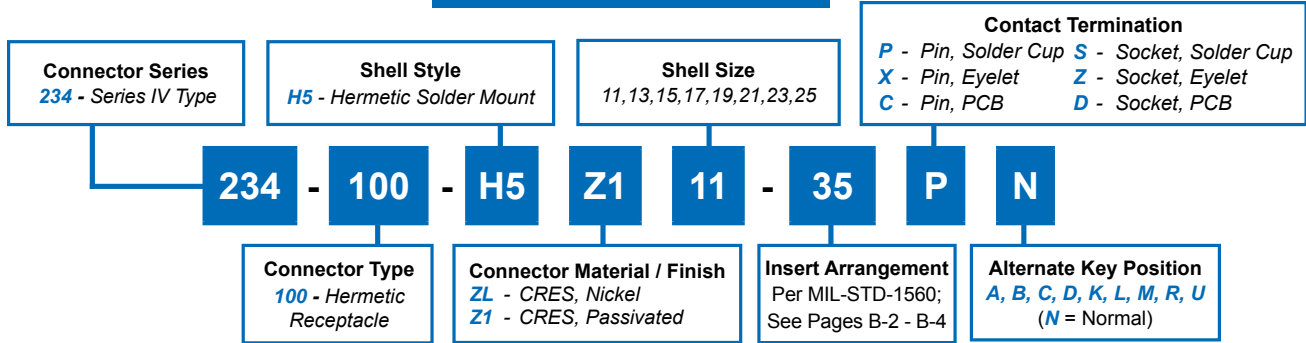

## How To Order: Commercial



**B**

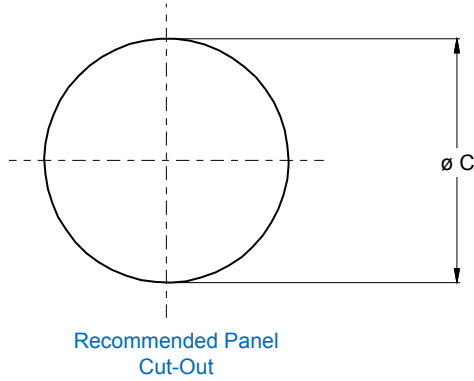

WIRE ACCOMODATION	
Contact Size	Wire Gauge
22D	#22 - #28
20	#20 - #24
16	#16 - #20
12	#12 - #14

HERMETIC LEAK RATE MOD CODES	
Designator	Required Leak Rate
-585A	1 x 10 <sup>-10</sup> cc Helium per second
-585B	1 x 10 <sup>-9</sup> cc Helium per second
-585C	1 x 10 <sup>-8</sup> cc Helium per second

TABLE I: CONNECTOR DIMENSIONS					
SHELL SIZE CODE	SHELL SIZE	ø A MAX	ø B MAX	ø C ±.005(0.1)	D
B	11	.783(19.9)	.862(21.9)	.789(20.0)	.793(20.1) .778(19.8)
C	13	.909(23.1)	.988(25.1)	.914(23.2)	.919(23.3) .904(23.0)
D	15	1.035(26.3)	1.110(28.2)	1.038(26.4)	1.044(26.5) 1.028(26.1)
E	17	1.157(29.4)	1.236(31.4)	1.164(29.6)	1.170(29.7) 1.155(29.3)
F	19	1.252(31.8)	1.331(33.8)	1.258(32.0)	1.294(32.9) 1.279(32.5)
G	21	1.378(35.0)	1.457(37.0)	1.383(35.1)	1.419(36.0) 1.404(35.7)
H	23	1.504(38.2)	1.583(40.2)	1.508(38.3)	1.544(39.2) 1.528(38.8)
J	25	1.630(41.4)	1.705(43.3)	1.643(41.7)	1.670(42.4) 1.654(42.0)

TABLE II: CONTACT SIZE	
PRINTED CIRCUIT TAIL CONFIGURATIONS CONTACT STYLE C AND D	
Contact Size	ø P
22D	.011 (0.28) .015 (0.38)
20	.024 (0.61) .028 (0.71)
16	.0635 (1.61) .0615 (1.56)
12	.095 (2.41) .093 (2.36)

Dimensions in Inches (millimeters) are subject to change without notice.