

LED SPECS	UNITS	BLUE	GREEN
FORWARD CURRENT	mA	20	20
FORWARD VOLTAGE	V	3.3 TYP - 4.0 MAX	2.1 TYP-2.5 MAX
LUMINOUS INTENSITY	mcd	1000 TYP	600 TYP

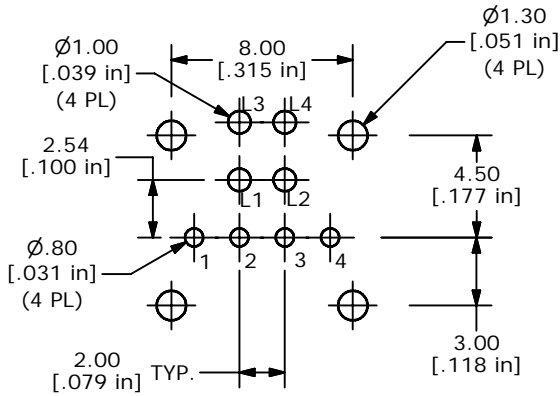

RECOMMENDED PCB LAYOUT

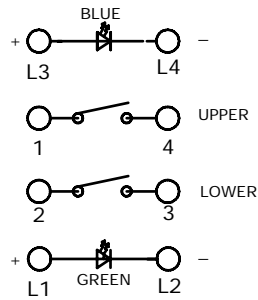

▲ CIRCUIT DIAGRAM

NOTES:

1. ALL DIMENSIONS IN MM
2. GENERAL TOLERANCE: X.X=±0.4
X.XX=±0.25
3. TERM. NOS. FOR REFERENCE ONLY.
4. CONTACT RATING: 50mA @12VDC
5. TRAVEL: 0.25 +0.2/-0.1mm
6. CONTACT RESISTANCE: 100 Milli-Ohms Max.
7. OPERATING FORCE: 160 ± 50gf
- ▲ 8. CONTACT MATERIAL: SILVER
9. MECHANICAL LIFE: 500,000 CYCLES
10. OPERATING TEMP: -20°C TO 70°C
- 11▲ DENOTES CRITICAL PARAMETER.
- ▲ 12. PACKAGE: TRAY/ 126 PIECES PER
13. 2002/95/EC (ROHS) COMPLIANT

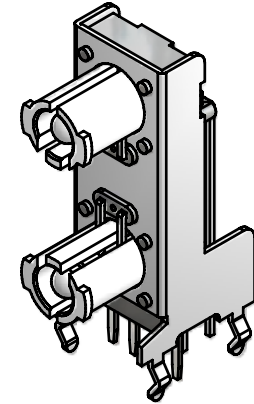
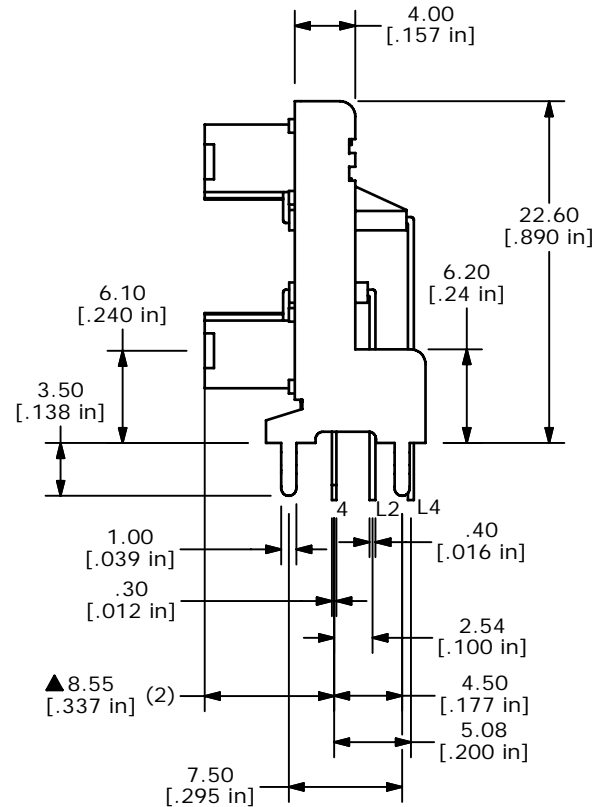
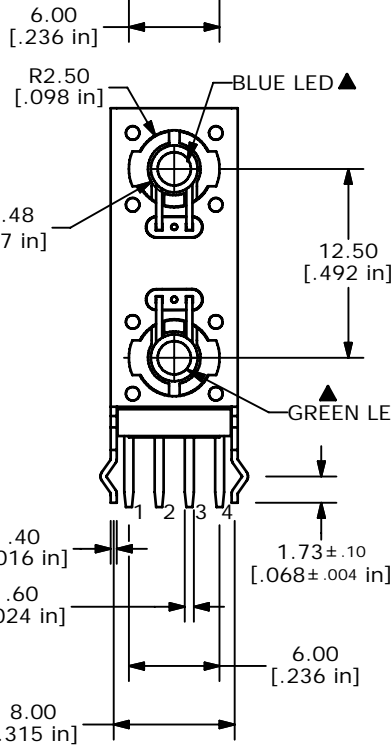
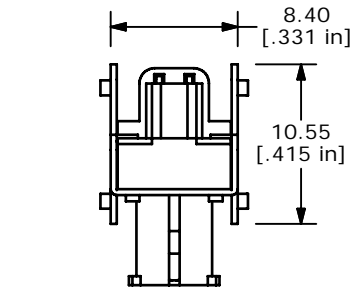

TITLE TL3253BBNBGNF160Q

A	20598	RELEASE FOR PRODUCTION	5/10/12	rc
REV	PCR NO	DESCRIPTION	DATE	BY

SCALE	DATE	DR	DWG	REV
2:1	5/10/2012	rc	B060004	A

THE INFORMATION CONTAINED IN THIS DOCUMENT IS PROPRIETARY TO E-SWITCH AND IS NOT TO BE COPIED OR TRANSFERRED