

ML22Q553-NNNMB/ML22Q553-xxxMB

4-Channel Mixing Speech Synthesis LSI with Built-in FLASH ROM for Automotive

GENERAL DESCRIPTION

The ML22Q553-NNN and ML22Q553-xxx are 4-channel mixing speech synthesis LSIs with built-in FLASH ROM for voice data. These LSIs incorporate into them an HQ-ADPCM decoder that enables high sound quality, 16-bit D/A converter, low-pass filter, 1.0 W monaural speaker amplifier for driving speakers, and over-current detectible function for Speaker Pins. Since functions necessary for voice output are all integrated into a single chip, a system can be upgraded with audio features by only using one of these LSIs.

- Capacity of internal memory and the maximum voice production time (when HQ-ADPCM^{※1} method used)

Product name	ROM capacity	Maximum voice production time (sec)		
		f _{sam} = 8.0 kHz	f _{sam} = 16.0 kHz	f _{sam} = 32.0 kHz
ML22Q553-NNN/-xxx	4 Mbits	161	80	40

FEATURES

- Speech synthesis method: Can be specified for each phrase.
HQ-ADPCM / 8-bit non-linear PCM / 8-bit PCM / 16-bit PCM
- Sampling frequency: Can be specified for each phrase.
12.0/24.0/48.0 kHz, 8.0/16.0/32.0 kHz, 6.4/12.8/25.6 kHz
- Built-in low-pass filter and 16-bit D/A converter
- Built-in speaker driver amplifier: 1.0 W, 8Ω (at DV_{DD} = 5 V)
(with over-current detectible function for Speaker pins)
- External analog voice input (built-in analog mixing function)
- CPU command interface: Clock synchronous serial interface
- Maximum number of phrases: 1024 phrases, from 000h to 3FFh
- Edit ROM
- Volume control: CVOL command: Adjustable through 32 levels (including OFF)
AVOL command: Adjustable through 50 levels (including OFF)
- Repeat function: LOOP command
- Channel mixing function: 4 channels
- Power supply voltage detection function: Can be controlled at six levels from 2.7 to 4.0 V (including the OFF setting)
- Source oscillation frequency: 4.096 MHz
- Power supply voltage: 4.5 to 5.5 V
- Operating temperature range: -40°C to +105°C^{※2}
- Package: heat sink type 30-pin plastic SSOP(P-SSOP30-56-0.65-Z6K)
- Product name: ML22Q553-NNNMB/ML22Q553-xxxMB
("xxx" denotes ROM code number)



HQ-ADPCM is a high sound quality audio compression technology of "Ky's".
"Ky's" is a Registered trademark of National Universities corporate Kyushu Institute of Technology

※2 The limitation on the operation time changes by the using condition. (Refer to Page66)

ML22Q553-NNN/ML22Q553-xxx

The table below summarizes the differences between the existing speech synthesis LSIs (ML225XG and ML22Q573) and the ML22Q553.

Item	ML225XG	ML22Q573	ML22Q553
CPU interface	Parallel/Serial	Serial	←
ROM type	MASK	FLASH	←
ROM capacity	3/4/6 Mbits	4 Mbits	←
Playback method	2-bit ADPCM2 4-bit ADPCM2 8-bit straight PCM 8-bit non-linear PCM 16-bit straight PCM	HQ-ADPCM 8-bit straight PCM 8-bit non-linear PCM 16-bit straight PCM	←
Maximum number of phrases	256	1024	←
Sampling frequency (kHz)	4.0/5.3/6.4/8.0/ 10.7/12.0/12.8/ 16.0/21.3/24.0/ 25.6/32.0/48.0	6.4/8.0/12.0/ 12.8/16.0/24.0/ 25.6/32.0/48.0	←
Clock frequency	4.096 MHz (has a crystal oscillator circuit built-in)	←	←
D/A converter	14-bit voltage-type	16-bit voltage-type	←
Low-pass filter	FIR interpolation filter	FIR interpolation filter (High-pass interpolation)	←
Speaker driving amplifier	No	Built-in 1.0 W (8Ω, DV _{DD} = 5 V)	←
Over-current detectible function for Speaker Pins	No	←	Yes
Simultaneous sound production function (mixing function)	2-channel	4-channel	←
Edit ROM	Yes	←	←
Volume control	29 levels	32 levels	←
Silence insertion	20 to 1024 ms (4 ms steps)	←	←
Repeat function	Yes	←	←
External analog input	No	Yes	←
External speech data input	Yes	No	←
Interval at which a seam is silent during continuous playback	No	←	←
Power supply voltage	2.7 V to 5.5 V	←	4.5 V to 5.5 V
Ambient temperature	-40°C to +105°C	←	←
Package	44-pin QFP	30-pin SSOP	←

BLOCK DIAGRAM

The block diagrams of the ML22Q553-NNN/ML22Q553-xxx are shown below.

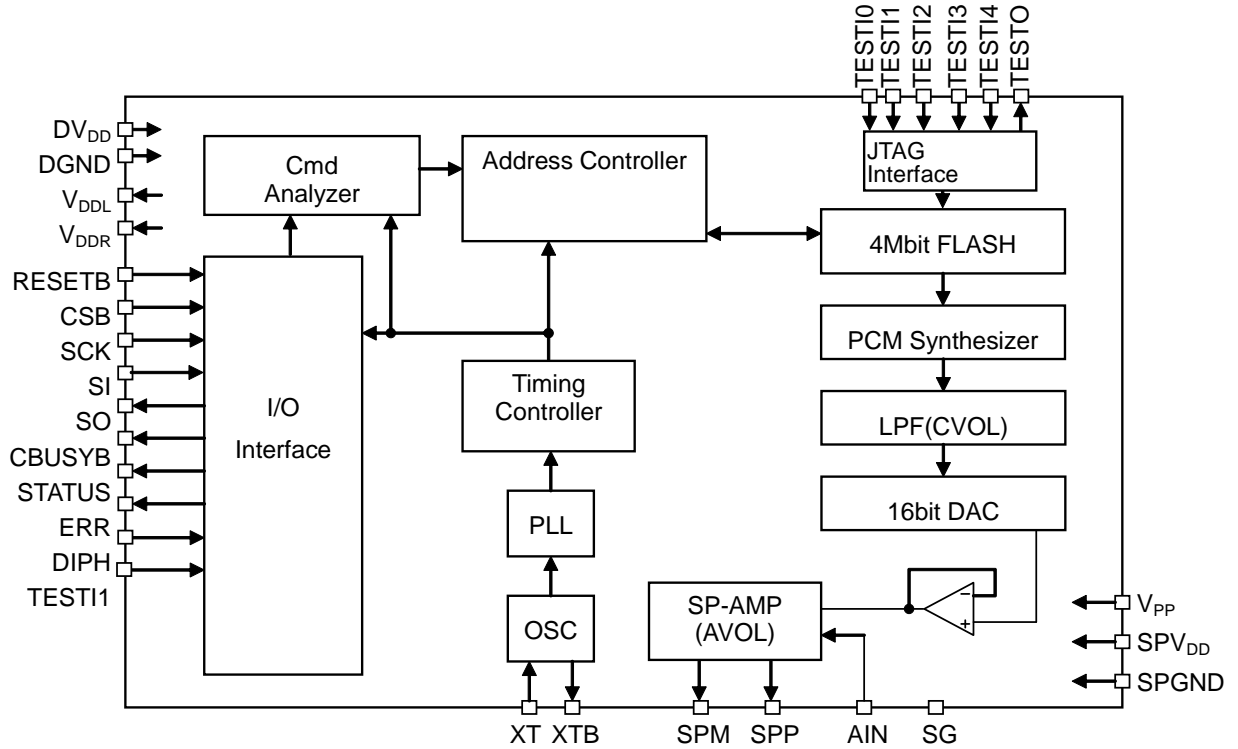

Block Diagram of ML22Q553-NNN/ML22Q553-xxx

PIN CONFIGURATION (TOP VIEW)

- ML22Q553-NNN/ML22Q553-xxx

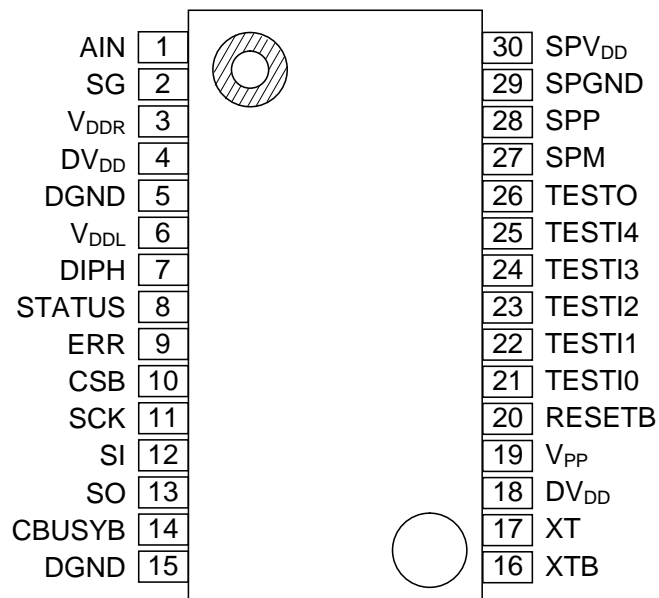

30-Pin Plastic SSOP

PIN DESCRIPTION (1)

Pin	Symbol	I/O	Attribute	Description	Attribute	Initial value
1	AIN	I	—	Speaker amplifier input pin.	analog	0
2	SG	O	—	Built-in speaker amplifier's reference voltage output pin. Connect a capacitor of 0.1 μ F or more between this pin and DGND.	analog	0
3	V _{DDR}	O	—	2.5 V regulator output pin. Acts as an internal power supply (for ROM). Connect a capacitor of 10 μ F or more between this pin and DGND.	analog	0
4,18	DV _{DD}	—	—	Digital power supply pin. Connect a bypass capacitor of 10 μ F or more between this pin and DGND.	power	—
5,15	DGND	—	—	Digital ground pin	gnd	—
6	V _{DDL}	O	—	2.5 V regulator output pin. Acts as an internal power supply (for logic). Connect a capacitor of 10 μ F or more between this pin and DGND.	power	0
7	DIPH	I	Positive	Serial interface switching pin. Pin for choosing between rising edges and falling edges as to the edges of the SCK pulses used for shifting serial data input to the SI pin into the inside of the LSI. When this pin is at a "L" level, SI input data is shifted into the LSI on the rising edges of the SCK clock pulses and a status signal is output from the SO pin on the falling edges of the SCK clock pulses. When this pin is at a "H" level, SI input data is shifted into the LSI on the falling edges of the SCK clock pulses and a status signal is output from the SO pin on the rising edges of the SCK clock pulses.	digital	0
8	STATUS	O	Positive	Channel status output pin. Outputs the BUSYB or NCR signal for each channel by inputting the OUTSTAT command.	digital	1
9	ERR	O	Positive	Error output pin. Outputs a "H" level if an error occurs.	digital	0
10	CSB	I	Negative	Chip select pin. A "L" level on this pin accepts the SCK or SI inputs. When this pin is at a "H" level, neither the SCK nor SI signal is input to the LSI.	digital	1
11	SCK	I	Positive	Synchronous serial clock input pin.	clk	0
12	SI	I	—	Synchronous serial data input pin. When the DIPH pin is at a "L" level, data is shifted in on the rising edges of the SCK clock pulses. When the DIPH pin is at a "H" level, data is shifted in on the falling edges of the SCK clock pulses.	digital	0
13	SO	O	Positive	Channel status serial output pin. Outputs a status signal on the falling edges of the SCK clock pulses when the DIPH pin is at a "L" level; outputs a status signal on the rising edges of the SCK clock pulses when the DIPH pin is at a "H" level. When the CSB pin is at a "L" level, the status of each channel is output serially in sync with the SCK clock. When the CSB pin is at a "H" level, this pin goes into a high impedance state.	digital	Hi-Z

PIN DESCRIPTION (2)

Pin	Symbol	I/O	Attribute	Description	Attribute	Initial value ^(*1)
14	CBUSYB	O	Negative	Command processing status signal output pin. This pin outputs a "L" level during command processing. Be sure to enter commands with the CBUSYB pin driven at a "H" level.	digital	0 ^(*1)
16	XTB	O	Negative	Connects to a crystal or a ceramic resonator. When using an external clock, leave this pin open. If a crystal or a ceramic resonator is used, connect it as close to the LSI as possible.	clk	1
17	XT	I	Positive	Connects to a crystal or a ceramic resonator. A feedback resistor of around 1 MΩ is built in between this XT pin and the XTB pin. When using an external clock, input the clock from this pin. If a crystal or a ceramic resonator is used, connect it as close to the LSI as possible.	clk	0
19	V _{PP}	I	—	Pin for FLASH analysis. Should be connected to DGND.	analog	0
20	RESETB	I	Negative	Reset input pin. At "L" level input, the LSI enters the initial state. After a reset input, the entire circuit is stopped and enters a power down state. Upon power-on, input a "L" level to this pin. After the power supply voltage is stabilized, drive this pin at a "H" level. This pin has a pull-up resistor built in.	digital	0 ^(*1)
21	TESTI0 (MODE)	I	Positive	Input pin for testing. Also acts as a Flash rewrite enable pin. Has a pull-down resistor built in.	digital	0
22	TESTI1 (nTRST)	I	Negative	Used as either an input pin for testing or a reset input pin for Flash rewriting. Has a pull-down resistor built in.	digital	0
23	TESTI2 (TMS)	I	Positive	Used as either an input pin for testing or a state transition pin for Flash rewriting. Has a pull-up resistor built in.	digital	1
24	TESTI3 (TDI)	I	Positive	Used as either an input pin for testing or a data input pin for Flash rewriting. Has a pull-up resistor built in.	digital	1
25	TESTI4 (TCK)	I	Positive	Used as either an input pin for testing or a clock input pin for Flash rewriting. Has a pull-up resistor built in.	digital	0
26	TESTO (TSO)	O	Positive	Used as either an output pin for testing or a data output pin for Flash rewriting.	digital	Hi-Z
27	SPM	O	—	Output pin of the built-in speaker amplifier.	analog	Hi-Z
28	SPP	O	—	Output pin of the built-in speaker amplifier. Can be configured as an AOUT amplifier output by command setting.	analog	0
29	SPGND	—	—	Speaker amplifier ground pin.	gnd	—
30	SPV _{DD}	—	—	Speaker amplifier power supply pin. Connect a bypass capacitor of 10μF or more between this pin and SPGND.	power	—

*1: Indicates the initial value at reset input or during power down.

ABSOLUTE MAXIMUM RATINGS

DGND = SPGND = 0 V, Ta = 25°C

Parameter	Symbol	Condition	Rating	Unit
Power supply voltage	DV _{DD} SPV _{DD}	—	-0.3 to +7.0	V
Input voltage	V _{IN}	—	-0.3 to DV _{DD} +0.3	V
Power dissipation	P _D	When the LSI is mounted on JEDEC 4-layer board. When SPV _{DD} = 5V	1000	mW
Output short-circuit current	I _{OS}	Applies to all pins except SPM, SPP, V _{DDL} , and V _{DDR} .	10	mA
		Applies to SPM and SPP pins.	500	mA
		Applies to V _{DDL} and V _{DDR} pins.	50	mA
Storage temperature	T _{STG}	—	-55 to +150	°C

RECOMMENDED OPERATING CONDITIONS

DGND = SPGND = 0 V

Parameter	Symbol	Condition	Range			Unit
DV _{DD} , SPV _{DD} Power supply voltage	DV _{DD} SPV _{DD}	—	4.5 to 5.5			V
Operating temperature	T _{OP}	—	-40 to +105			°C
Master clock frequency	f _{OSC}	—	Min.	Typ.	Max.	MHz
			3.5	4.096	4.5	

FLASH CONDITIONS

DGND = SPGND = 0 V

Parameter	Symbol	Condition	Range	Unit
Operating temperature	T _{OP}	At write/erase	0 to +70	°C
		At read	-40 to +105	°C
Maximum rewrite count	C _{EP}	—	10	times
Data retention period	Y _{DR}	—	10	years

ELECTRICAL CHARACTERISTICS

DC Characteristics

DV_{DD} = SPV_{DD} = 4.5 to 5.5 V, DGND = SPGND = 0 V, Ta = -40 to +105°C

Parameter	Symbol	Condition	Min.	Typ.	Max.	Unit
"H" input voltage	V _{IH}	—	0.8×DV _{DD}	—	DV _{DD}	V
"L" input voltage	V _{IL}	—	0	—	0.2×DV _{DD}	V
"H" output voltage 1	V _{OH1}	I _{OH} = -1 mA	DV _{DD} -0.4	—	—	V
"H" output voltage 2 (*1)	V _{OH2}	I _{OH} = -50 μA	DV _{DD} -0.4	—	—	V
"L" output voltage 1	V _{OL1}	I _{OL} = 2 mA	—	—	0.4	V
Output leakage current(*2)	I _{OOH}	VOH = DV _{DD} (CSB="H")	—	—	10	μA
	I _{OOL}	VOL = DGND (CSB="H")	-10	—	—	μA
"L" output voltage 2 (*1)	V _{OL2}	I _{OL} = 50 μA	—	—	0.4	V
"H" input current 1	I _{IH1}	V _{IH} = DV _{DD}	—	—	10	μA
"H" input current 2 (*3)	I _{IH2}	V _{IH} = DV _{DD}	0.8	5	20	μA
"H" input current 3 (*4)	I _{IH3}	V _{IH} = DV _{DD}	20	100	400	μA
"L" input current 1	I _{IL1}	V _{IL} = DGND	-10	—	—	μA
"L" input current 2 (*3)	I _{IL2}	V _{IL} = DGND	-20	-5.0	-0.8	μA
"L" input current 3 (*5)	I _{IL3}	V _{IL} = DGND	-400	-100	-20	μA
Supply current during playback 1	I _{DD1}	f _{OSC} = 4.096 MHz f _s =48kHz, f=1kHz, When 16bitPCM Playback No output load	—	—	55	mA
Supply current during playback 3	I _{DD3}	f _{OSC} = 4.096 MHz During silence playback No output load	—	—	48	mA
Power-down supply current	I _{DDS1}	Ta = -40 to +55°C	—	—	50	μA
		Ta = -40 to +105°C	—	—	100	μA

*1: Applies to the XTB pin.

*2: Applies to the SO and TEST0 pins.

*3: Applies to the XT pin.

*4: Applies to the TESTI0 and TESTI1 pins.

*5: Applies to the RESETB, TEST2, TEST3 and TEST4 pins.

Analog Section Characteristics

 $DV_{DD} = SPV_{DD} = 4.5 \text{ to } 5.5 \text{ V}$, $DGND = SPGND = 0 \text{ V}$, $T_a = -40 \text{ to } +105^\circ\text{C}$

Parameter	Symbol	Condition	Min.	Typ.	Max.	Unit
AIN input resistance	R_{AIN}	Input gain: 0 dB	10	20	30	$k\Omega$
AIN input voltage range	V_{AIN}		—	—	$SPV_{DD} \times \frac{2}{3}$	Vp-p
Line output resistance	R_{LA}	At $1/2SPV_{DD}$ output	—	—	100	Ω
LINE output load resistance	R_{LA}	At SPGND10k Ω load	10	—	—	$k\Omega$
LINE output voltage range	V_{AO}	At SPGND10k Ω load	$SPV_{DD} / 6$	—	$SPV_{DD} \times \frac{5}{6}$	V
SG output voltage	V_{SG}	—	$0.95x$ $SPV_{DD} / 2$	$SPV_{DD} / 2$	$1.05x$ $SPV_{DD} / 2$	V
SG output resistance	R_{SG}	—	57	96	135	$k\Omega$
SPM, SPP output load resistance	R_{LSP}	—	6	8	—	Ω
Speaker amplifier output power	P_{SPO}	$SPV_{DD} = 5.0\text{V}$, $f = 1 \text{ kHz}$ $R_{SPO} = 8\Omega$, $THD \leq 10\%$	800	1000	—	mW
Output offset voltage between SPM and SPP with no signal present	V_{OF}	SPIN-SPM gain = 0 dB With a load of 8 Ω	-50	—	+50	mV
Regulator output voltage	V_{DDL} V_{DDR}	Output load current = -35 mA	2.25	2.5	2.75	V

AC Characteristics (1)

DV_{DD} = SPV_{DD} = 4.5 to 5.5 V, DGND = SPGND = 0 V, Ta = -40 to +105°C

Parameter	Symbol	Condition	Min.	Typ.	Max.	Unit
Master clock duty cycle	f _{duty}	—	40	50	60	%
RESETB input pulse width	t _{RST}	—	10	—	—	μs
Reset noise rejection pulse width	t _{NRST}	RESETB pin	—	—	0.1	μs
Noise rejection pulse width	t _{NINP}	CSB, SCK, and SI pins	—	—	5	ns
Command input interval time1	t _{INT}	f _{OSC} = 4.096 MHz At STOP/SLOOP/CLOOP/ VOL command input After status read	10	—	—	μs
Command input interval time2	t _{INTC}	f _{OSC} = 4.096 MHz After input first command at two-time command input mode	0	—	—	μs
Command input enable time	t _{cm}	f _{OSC} = 4.096 MHz During continuous playback At SLOOP input	—	—	10	ms
At PUP command input CBUSYB "L" level output time	t _{PUP}	4.096 MHz At external clock input	—	—	4	ms
At AMODE command input CBUSYB "L" level output time (*3)	t _{PUPA1}	4.096 MHz At external clock input POP = "0" DAEN = "0"→"1" or SPEN = "0"→"1"	39	41	43	ms
At AMODE command input CBUSYB "L" level output time	t _{PUPA2}	4.096 MHz At external clock input POP = "1" DAEN = "0"→"1" (SPEN = "0")	72	74	76	ms
At AMODE command input CBUSYB "L" level output time	t _{PUPA3}	4.096 MHz At external clock input POP = "0" DAEN = "0"→"1" (SPEN = "0")	32	34	36	ms
At PDWN command input CBUSYB "L" level output time	t _{PD}	f _{OSC} = 4.096 MHz	—	—	10	μs
At AMODE command input CBUSYB "L" level output time (*3)	t _{PDA1}	4.096 MHz At external clock input POP = "0" DAEN = "1"→"0" or SPEN = "1"→"0"	106	108	110	ms
At AMODE command input CBUSYB "L" level output time	t _{PDA2}	4.096 MHz At external clock input POP = "1" DAEN = "1"→"0" (SPEN = "0")	143	145	147	ms
At AMODE command input CBUSYB "L" level output time	t _{PDA3}	4.096 MHz At external clock input POP = "0" DAEN = "1"→"0" (SPEN = "0")	103	105	107	ms
CBUSYB "L" level output time 1 (*1)	t _{CB1}	f _{OSC} = 4.096 MHz	—	—	10	μs
CBUSYB "L" level output time 2 (*2)	t _{CB2}	f _{OSC} = 4.096 MHz	—	—	3	ms
CBUSYB "L" level output time 3 (*4)	t _{CB3}	f _{OSC} = 4.096 MHz	—	—	200	μs

Note: Output pin load capacitance = 45 pF (Max.)

- *1: Applies to cases where a command is input, except after the PUP, PDWN, PLAY, START or AMODE command input.
- *2: Applies to cases where the PLAY or START command is input.
- *3: When FAD3-0 is initial value (8h)
- *4: Applies to cases where the STOP command is input.

AC Characteristics (2)

 $DV_{DD} = SPV_{DD} = 4.5 \text{ to } 5.5 \text{ V}$, $DGND = SPGND = 0 \text{ V}$, $T_a = -40 \text{ to } +105^\circ\text{C}$

Parameter	Symbol	Condition	Min.	Typ.	Max.	Unit
SCK input enable time from CSB fall	t_{ESCK}	—	100	—	—	ns
SCK hold time from CSB rise	t_{CSH}	—	100	—	—	ns
Data floating time from CSB rise	t_{DOZ}	$R_L = 3 \text{ k}\Omega$	—	—	100	ns
Data setup time from SCK rise	t_{DIS1}	DIPH = "L"	50	—	—	ns
Data hold time from SCK rise	t_{DIH1}	DIPH = "L"	50	—	—	ns
Data output delay time from SCK rise	t_{DOD1}	$R_L = 3 \text{ k}\Omega$	—	—	90	ns
Data setup time from SCK fall	t_{DIS2}	DIPH = "H"	50	—	—	ns
Data hold time from SCK fall	t_{DIH2}	DIPH = "H"	50	—	—	ns
Data output delay time from SCK rise	t_{DOD2}	$R_L = 3 \text{ k}\Omega$	—	—	90	ns
SCK "H" level pulse width	t_{SCKH}	—	100	—	—	ns
SCK "L" level pulse width	t_{SCKL}	—	100	—	—	ns
CBUSYB output delay time from SCK rise	t_{DBSY1}	DIPH = "L"	—	—	90	ns
CBUSYB output delay time from SCK fall	t_{DBSY2}	DIPH = "H"	—	—	90	ns

Note: Output pin load capacitance = 45 pF (Max.)

TIMING DIAGRAMS

Serial Interface Data Input Timing (When DIPH = "L")

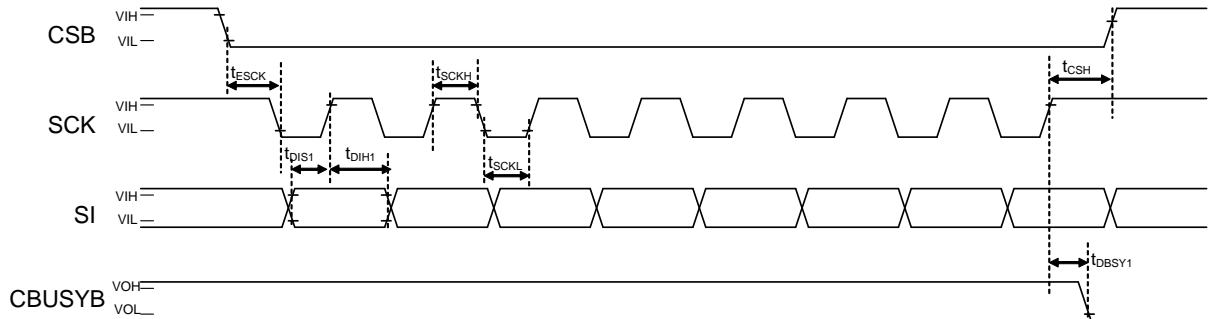

Serial Interface Data Input Timing (When DIPH = "H")

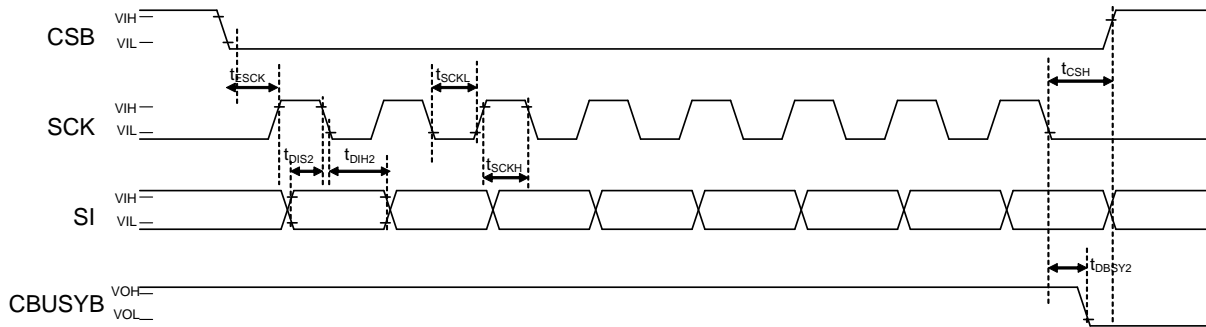

Serial Interface Data Output Timing (When DIPH = "L")

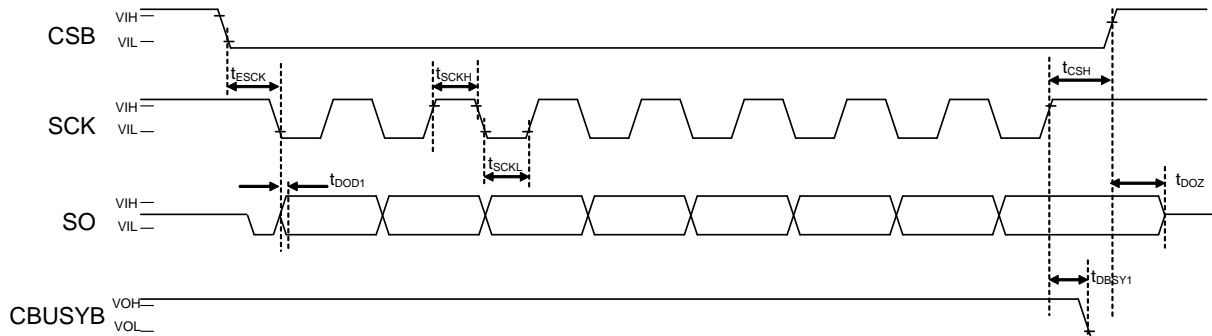

Serial Interface Data Output Timing (When DIPH = "H")

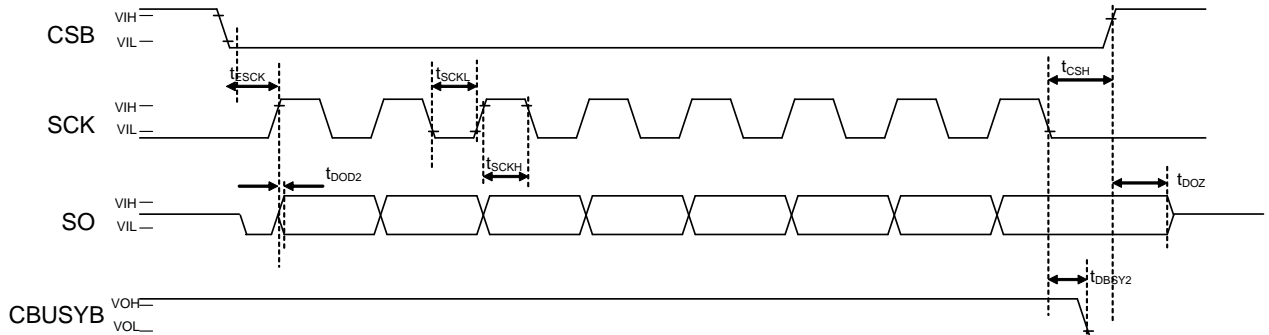

Power-On Timing

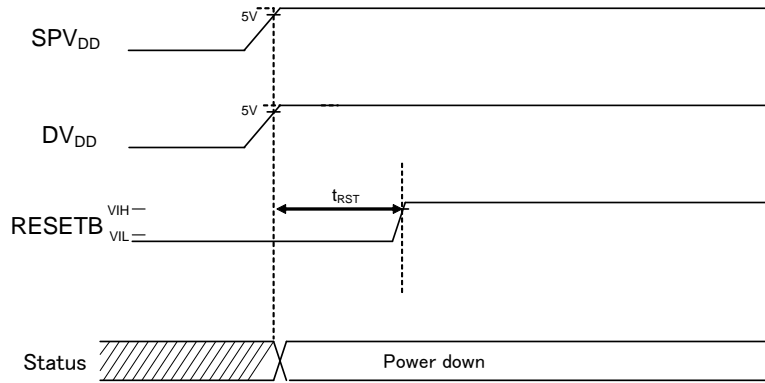

Oscillation is stopped after power-on.
Be sure to set "L" level the RESETB pin before the first command input.

Power-Up Timing

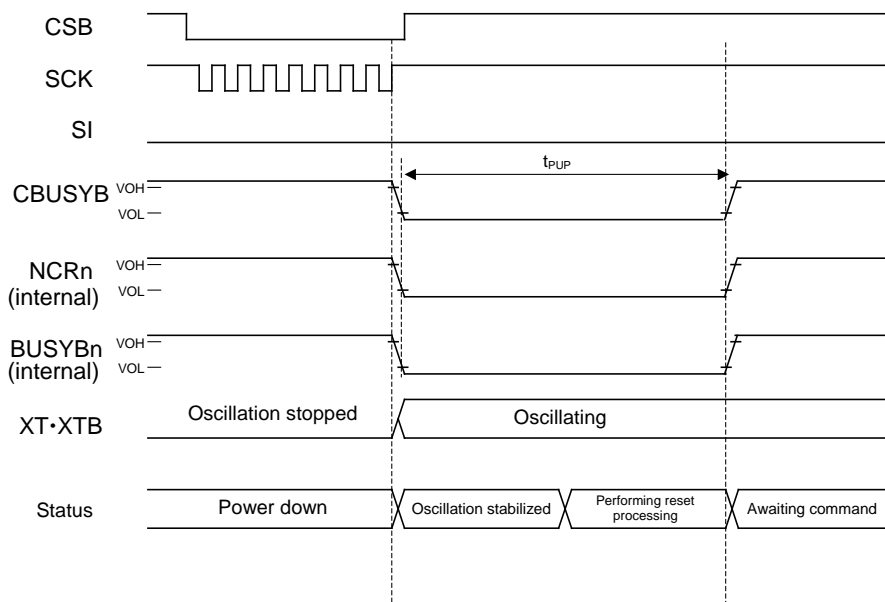

Power-Down Timing

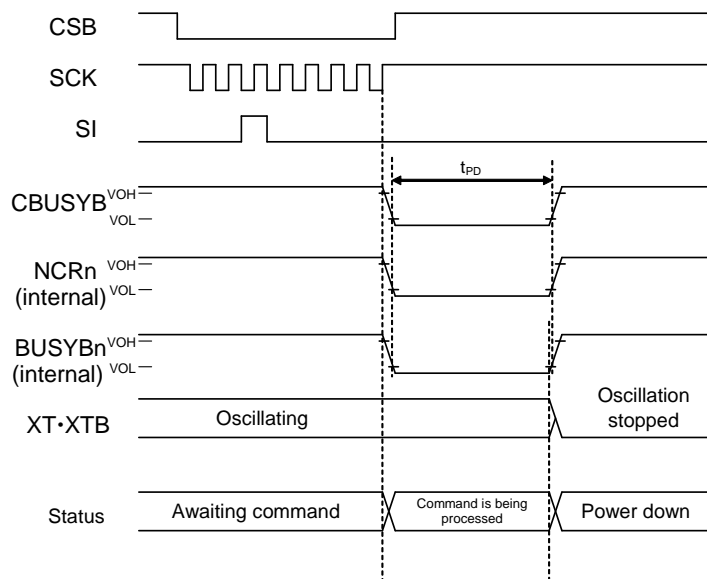

Reset Input Timing

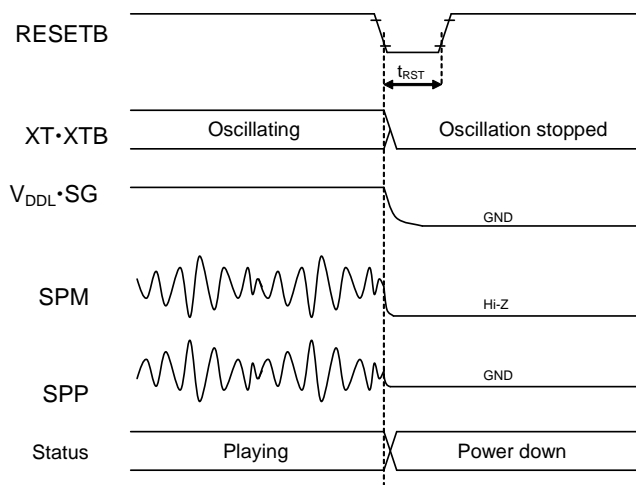

Note: The same timing applies in cases where the Reset signal is input during waiting for command.

Playback Start Timing by the PLAY Command

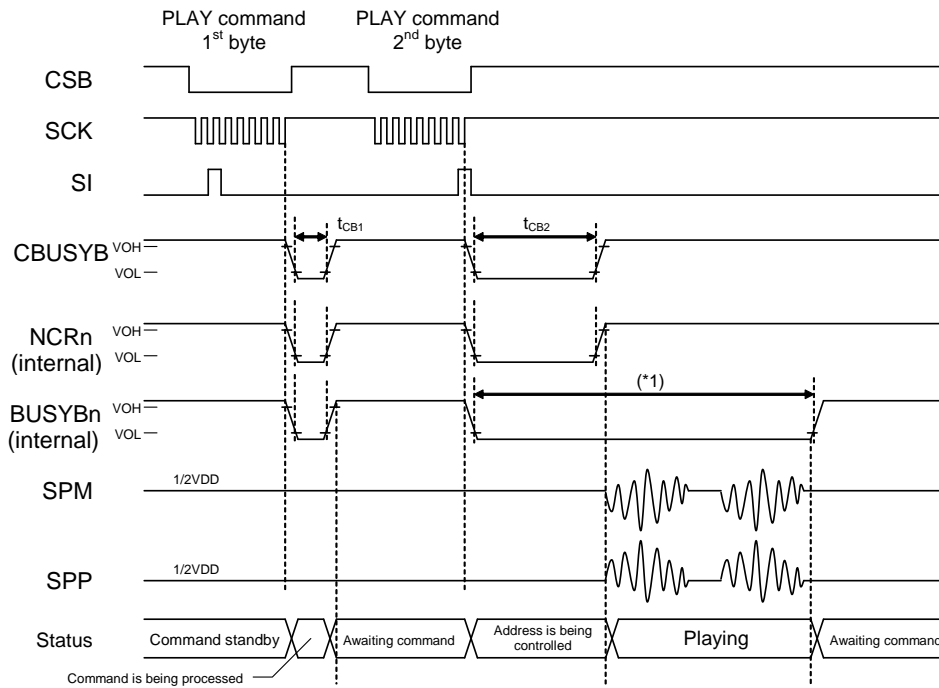

*1: Length of the “L” interval of BUSYBn is = t_{CB2} + voice production time length.

Playback Stop Timing

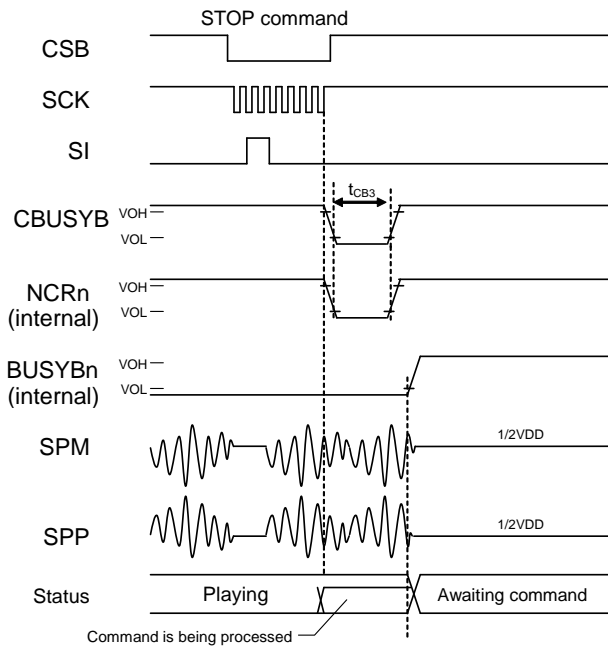

Continuous Playback Timing by the PLAY Command

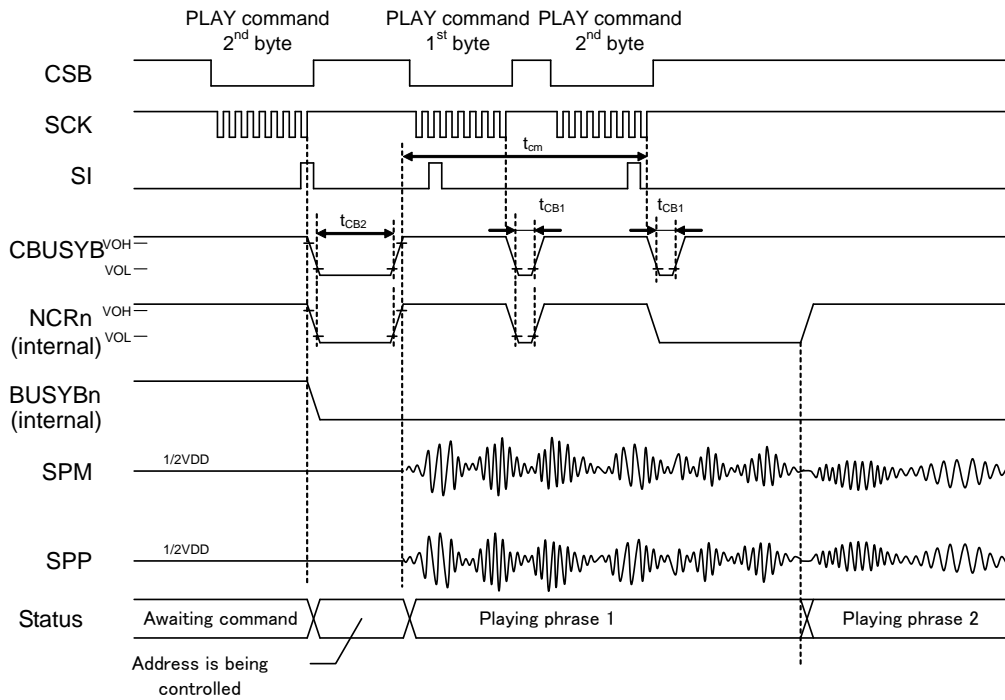

Silence Insertion Timing by the MUON Command

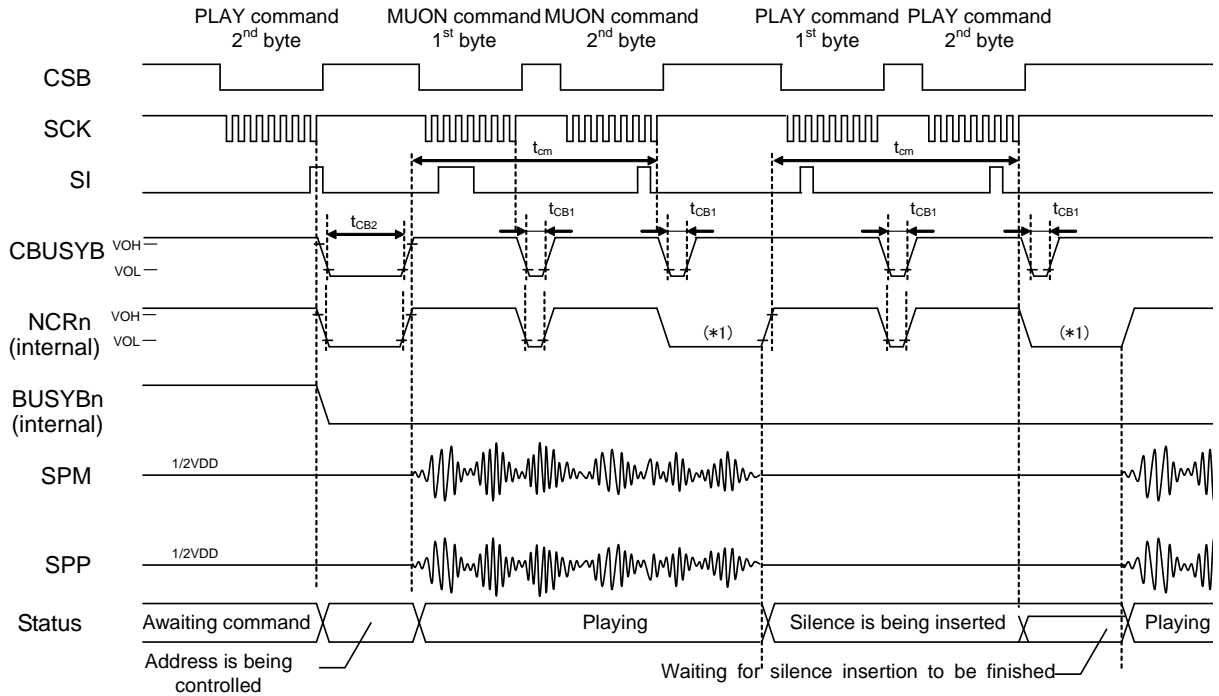

*1: The "L" level period of the NCR pin during playback or silence insertion operation varies depending on the timing at which the MUON command is input.

Repeat Playback Set/Release Timing by the SLOOP and CLOOP Commands

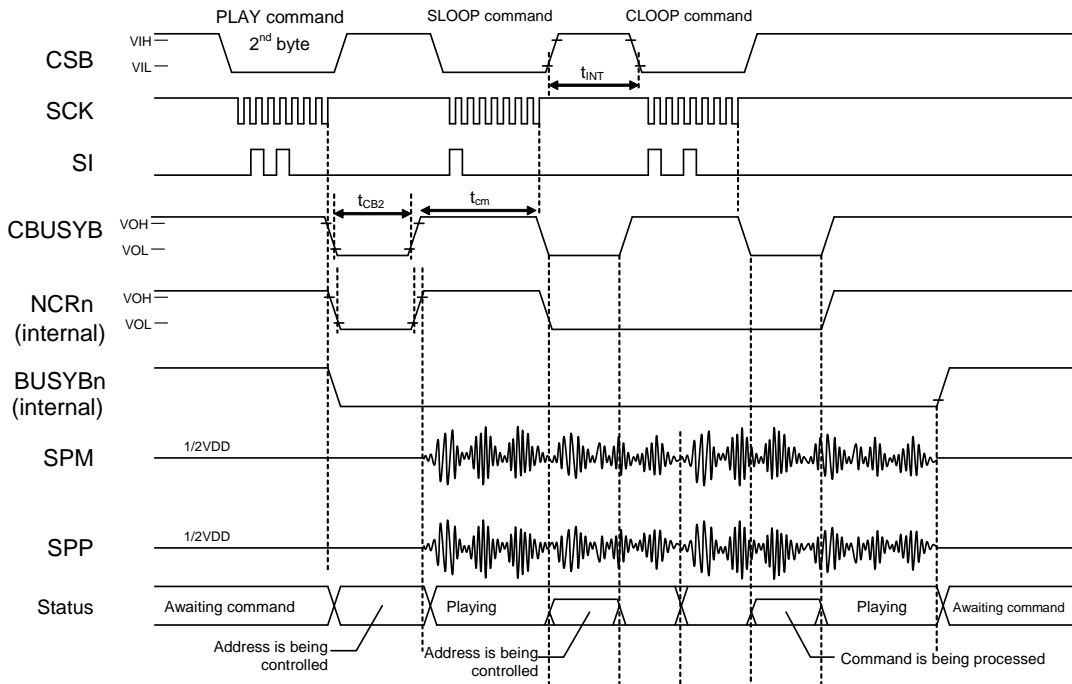

Timing of Volume Change by the CVOL Command

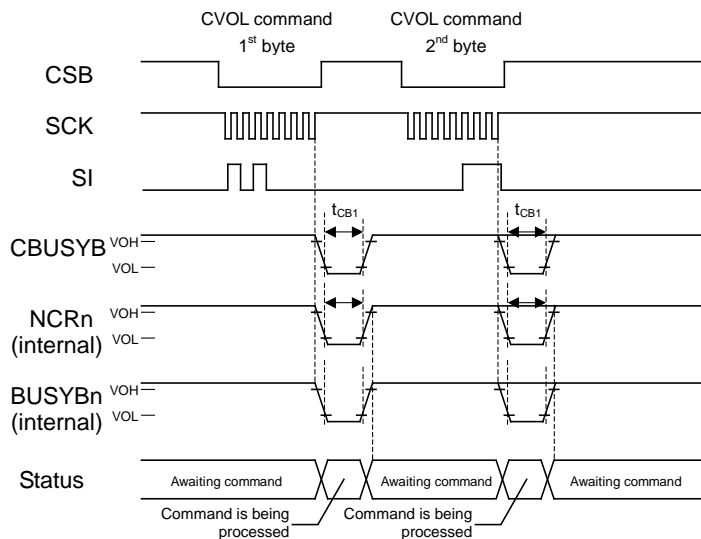

FUNCTIONAL DESCRIPTION

Synchronous Serial Interface

The CSB, SCK, SI, and SO pins are used to input various commands or read the status of the device. For command input, after inputting a “L” level to the CSB pin, input data through the SI pin with MSB first in sync with the SCK clock signal. The data input through the SI pin is shifted into the LSI in sync with the SCK clock signal, then the command is executed at the eighth pulse of the rising or falling edge of the SCK clock. For status reading, after a “L” level is input to the CSB pin, status is output from the SO pin in sync with the SCK clock signal.

Choosing between rising edges and falling edges of the clock pulses input through the SCK pin is determined by the signal input through the DIPH pin:

- When the DIPH pin is at a “L” level, the data input through the SI pin is shifted into the LSI on the rising edges of the SCK clock pulses and a status signal is output from the SO pin on the falling edges of the SCK clock pulses.

- When the DIPH pin is at a “H” level, the data input through the SI pin is shifted into the LSI on the falling edges of the SCK clock pulses and a status signal is output from the SO pin on the rising edges of the SCK clock pulses.

It is possible to input commands even with the CSB pin tied to a “L” level. However, if unexpected pulses caused by noise etc. are induced through the SCK pin, SCK clock pulses are incorrectly counted, causing a failure in normal input of command. In addition, the serial interface can be brought back to its initial state by driving the CSB pin at a “H” level.

When the CSB pin is at a “L” level, the status of each channel is output serially in sync with the SCK clock. When the CSB pin is at a ”H” level, the SO pin goes into a high impedance state.

- Command Input Timing: SCK rising edge operation (when DIPH pin = “L” level)

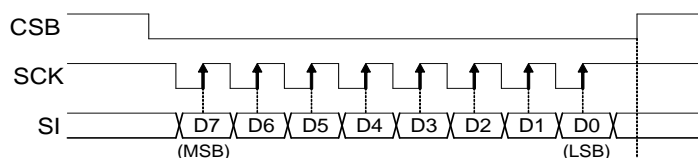

- Command Input Timing: SCK falling edge operation (when DIPH pin = “H” level)

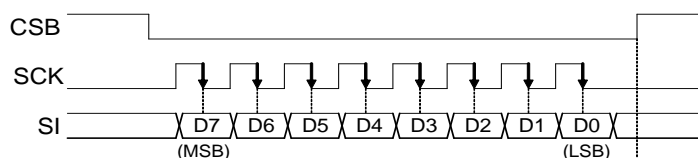

- Command Output Timing: SCK falling edge operation (when DIPH pin = “L” level)

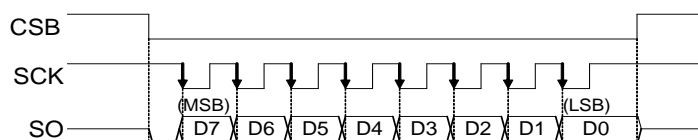

- Command Output Timing: SCK rising edge operation (when DIPH pin = “H” level)

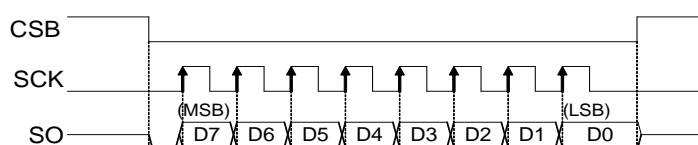

To prevent malfunction caused by serial interface pin noise, the ML22Q553 is provided with the two-time command input mode, where the user inputs one command two times. Use the PUP command to set the two-time command input mode. For the method of setting the two-time command input mode, see the section on “1. PUP command” described later.

In two-time command input mode, input one command two times in succession. Then, the command becomes valid only when the data input first matches the data input second. After the first data input, if a data mismatch occurs when the second data is input, a “H” level is output from the ERR pin. An error, if occurred, can be cleared by the ERCL command.

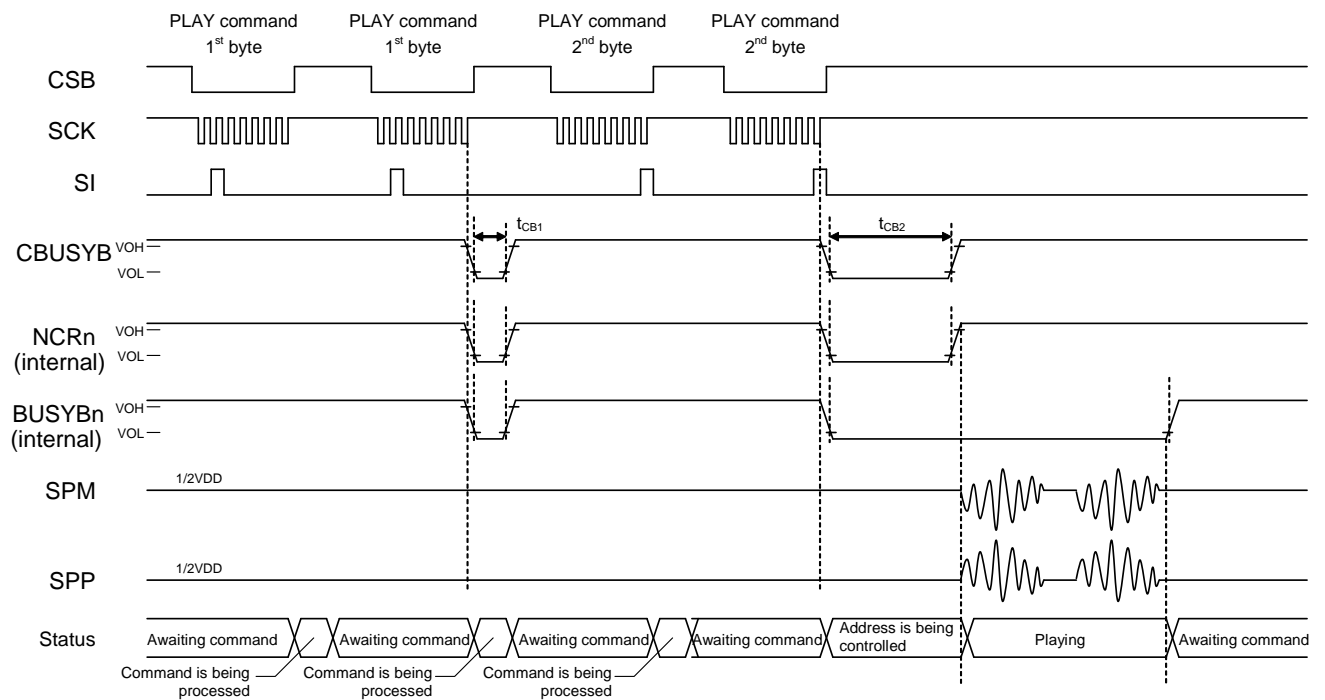

Voice Synthesis Algorithm

The ML22Q553 contains four algorithm types to match the characteristic of playback voice: HQ-ADPCM algorithm, 8-bit straight PCM algorithm, 8-bit non-linear PCM algorithm, and 16-bit straight PCM algorithm. Key feature of each algorithm is described in the table below.

Voice synthesis algorithm	Feature
HQ-ADPCM	Algorithm that enables high sound quality and high compression, which have been achieved by the improved 4-bit ADPCM that uses variable bit-length coding.
8-bit Nonlinear PCM	Algorithm that plays back mid-range of waveform as 10-bit equivalent voice quality.
8-bit PCM	Normal 8-bit PCM algorithm
16-bit PCM	Normal 16-bit PCM algorithm

Memory Allocation and Creating Voice Data

The ROM is partitioned into four data areas: voice (i.e., phrase) control area, test area, voice area, and edit ROM area.

The voice control area manages the ROM’s voice data. It contains data for controlling the start/stop addresses of voice data for 1024 phrases, use/non-use of the edit ROM function and so on.

The test area contains data for testing.

The voice area contains actual waveform data.

The edit ROM area contains data for effective use of voice data. For the details, refer to the section on “Edit ROM Function.”

No edit ROM area is available unless the edit ROM is used.

The ROM data is created using a dedicated tool.

Configuration of ROM data

0x00000	Voice control area (Fixed 64 Kbits)
0x01FFF	
0x02000	Test area
0x0206F	
0x02070	Voice area
max: 0x7FEBF	
max: 0x7FEBF	
0x7FEC0	Edit ROM area Depends on creation of ROM data.
max: 0x7FFFF	Filter area

Playback Time and Memory Capacity

The playback time depends on the memory capacity, sampling frequency, and playback method.

The equation showing the relationship is given below.

The equation below gives the playback time when the edit ROM function is not used.

$$\text{Playback time} = \frac{1.024 \times (\text{Memory capacity} - 64) \text{ (Kbits)}}{\text{Sampling frequency (kHz)} \times \text{Bit length}} \text{ (sec)}$$

Example: Let the sampling frequency be 16 kHz and HQ-ADPCM algorithm. Then the playback time is approx. 80 seconds, as shown below.

$$\text{Playback time} = \frac{1.024 \times (4096 - 64) \text{ (Kbits)}}{16 \text{ (kHz)} \times 3.2 \text{ (bits) (average)}} \cong 80 \text{ (sec)}$$

Edit ROM Function

With the edit ROM function, multiple phrases can be played in succession. The following functions can be configured using the edit ROM function:

- Continuous playback: There is no limit to the continuous playback count that can be specified. It depends on the memory capacity only.
- Silence insertion: 20 to 1024 ms

Using the edit ROM function enables an effective use of the memory capacity of voice ROM. Below is an example of the ROM configuration in the case of using the edit ROM function.

Examples of Phrases Using the Edit ROM Function

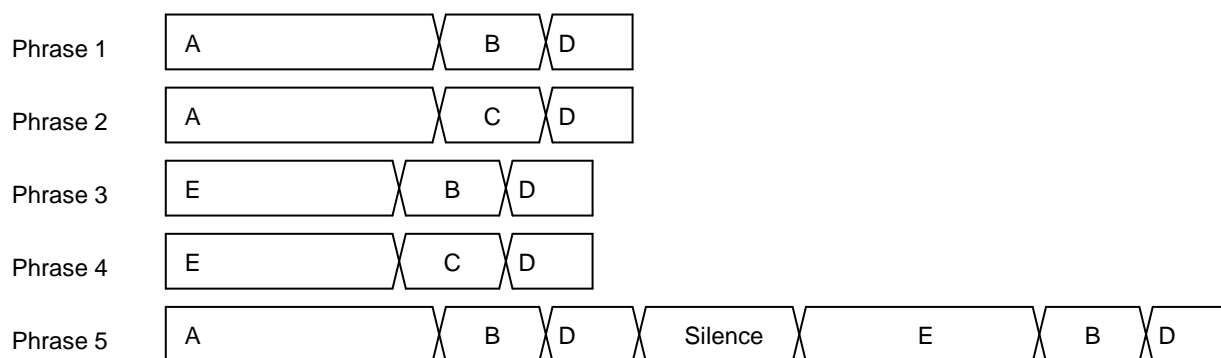

Example of ROM Data Where the Contents Above Are Stored in ROM

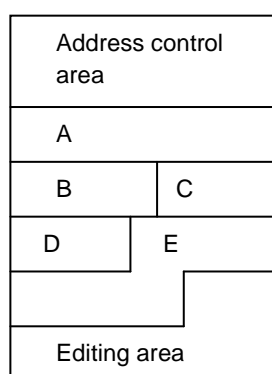

Mixing Function

The ML22Q553 can perform simultaneous mixing of four channels. It is possible to specify FADR, PLAY, STOP, and CVOL for each channel separately.

• Precautions for Waveform Clamp at the Time of Channel Mixing

If channel mixing is done, the possibility of an occurrence of a clamp increases from the mixing calculation point of view. If it is known beforehand that a clamp will occur, then adjust the sound volume of each channel using the VOL command.

• Mixing of Different Sampling Frequency

It is not possible to perform channel mixing by a different sampling frequency group.

When performing channel mixing, the sampling frequency group of the first playback channel is selected. Therefore, note that if channel mixing is performed by a sampling frequency group other than the selected sampling frequency group, then the playback will not be of constant speed: some times faster and at other times slower.

The available sampling groups for channel mixing by a different sampling frequency are listed below.

- 8.0 kHz, 16.0 Hz, 32.0 kHz ... (Group 1)
- 12.0 kHz, 24.0 kHz, 48 kHz ... (Group 2)
- 6.4 kHz, 12.8 kHz, 25.6 kHz ... (Group 3)

Figures below show cases where a phrase is played at a sampling frequency belonging to a different sampling frequency group.

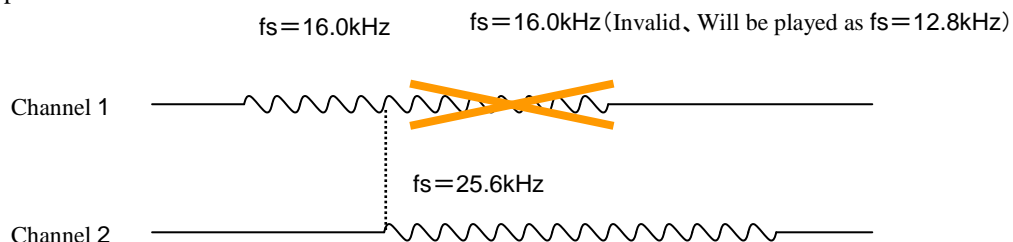

Figure 1 Case where a phrase is played at a sampling frequency belonging to a different sampling frequency group during playback on channels 1 and 2

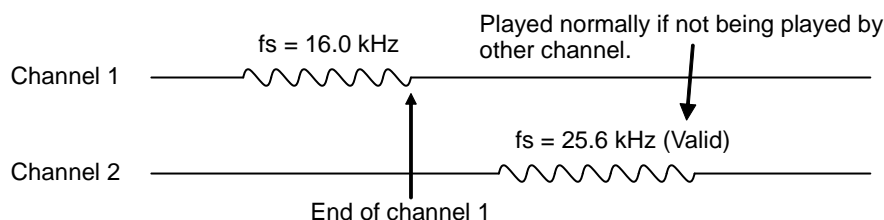
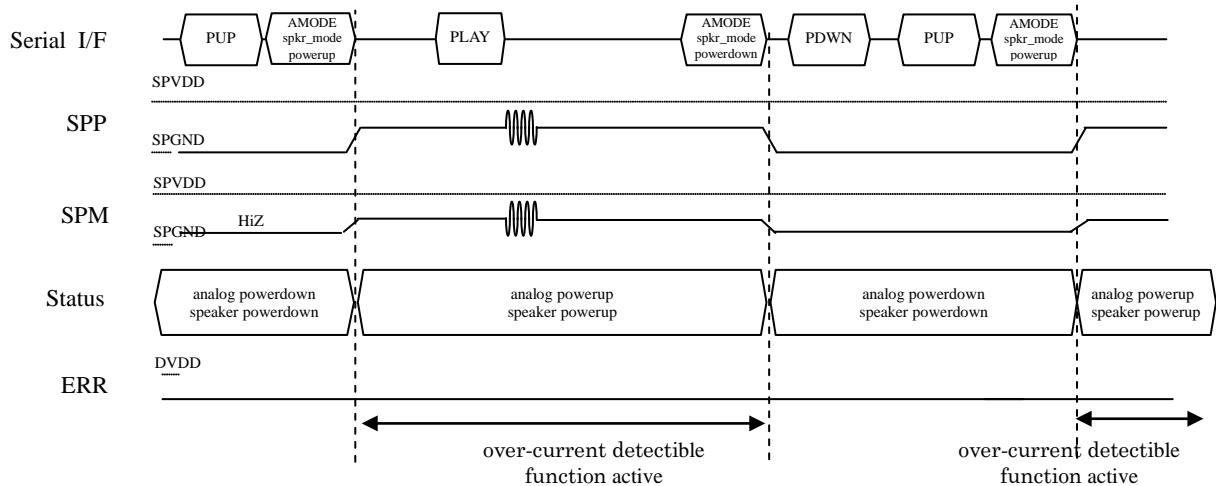

Figure 2 Case where a phrase is played at a sampling frequency belonging to a different sampling frequency group after playback is finished at the other channel

Over-current detectible function at Speaker pins

The over-current detectible function for the Speaker pins detect a short between SPP and SPM, and a short between SPP/SPM and GND.

The over-current detectible function is effective on speaker power-up by the AMODE command.



over-current detectible function for Speaker pins

When the over-current is detected, the speaker amplifier output pin(SPP/SPM) go to power-down forcibly, and a short error is informed by the ERR pin “H”.

In the case of error outbreak, please confirm a status of error by the RDSTAT command, stop playback, and set the speaker power-down by the AMODE command. Afterwards, please clear an error by the ERCL command. If performing playback again, set the speaker power-up by the AMODE command, and next set the PLAY command.

However, when shorting to GND is going on, even if the following operation is done, the speaker amplifier output pin(SPP/SPM) go to power-down forcibly, and the ERR pin becomes “H”.

- (1)After setting power-down by the AMODE command , do power-up by the AMODE command
- (2)After detect a short error, when input ERCL command without power-down operation of speaker amplifier by the AMODE command

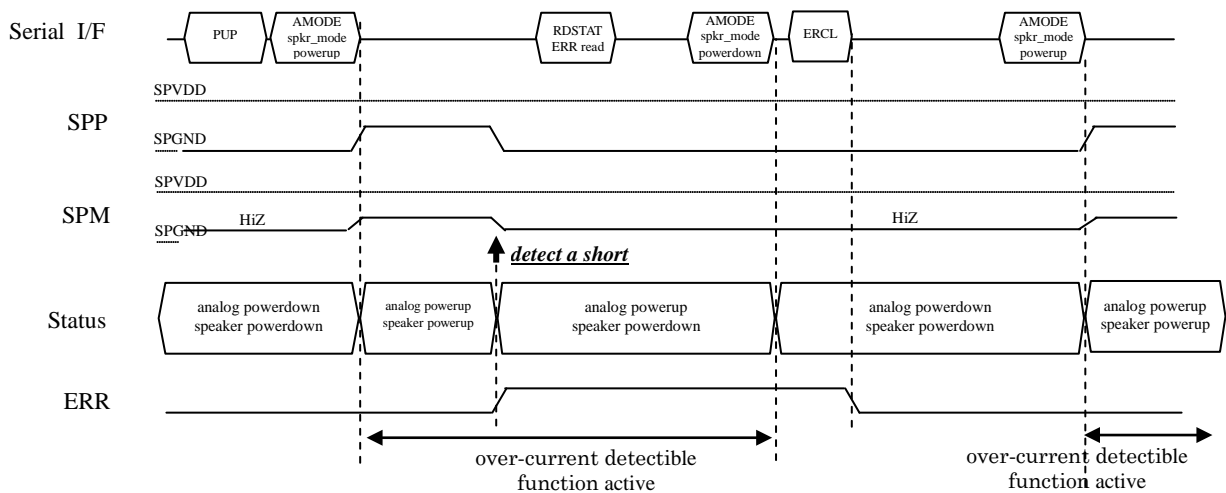

over-current detectible function Operation Flow (Example)

Command List

Each command is configured in 1-byte (8-bit) units. Each of the AMODE, AVOL FADR, PLAY, MUON, and CVOL commands forms one command by two bytes. Be sure to input the following commands only. Input each command with CBUSYB set to a "H" level.

Command	D7	D6	D5	D4	D3	D2	D1	D0	Description
PUP	0	0	0	0	0	0	0	WCM	Shifts the device currently powered down to a command wait state. Also the two-time command input mode is set by this command.
AMODE	0	0	0	0	0	1	HPF1	HPF0	Analog section control command. Configures settings for power-up operation and analog input/output. Selects the type of HPF.
	0	DAG1	DAG0	AIG1	AIG0	DAEN	SPEN	POP	
AVOL	0	0	0	0	1	0	0	0	Analog mixing signal volume setting command. Use the data of the 2nd byte to specify volume.
	—	—	AV5	AV4	AV3	AV2	AV1	AV0	
FAD	0	0	0	0	1	1	0	0	Sets the fade-in time in cases where the speaker amplifier is enabled by the AMODE command.
	0	0	0	0	FAD3	FAD2	FAD1	FAD0	
PDWN	0	0	1	0	0	0	0	0	Shifts the device from a command wait state to a power-down state.
FADR	0	0	1	1	C1	C0	F9	F8	Playback phrase specification command. Can be specified for each channel.
	F7	F6	F5	F4	F3	F2	F1	F0	
PLAY	0	1	0	0	C1	C0	F9	F8	Playback start command. Use the data of the 2nd byte to specify a phrase number. Can be specified for each channel.
	F7	F6	F5	F4	F3	F2	F1	F0	
START	0	1	0	1	CH3	CH2	CH1	CH0	Playback start command without phrase specification. Used to start playback on multiple channels at the same time after phrases are specified with the FADR command. After a phrase is played with the PLAY command, the same phrase can be played with this command.
STOP	0	1	1	0	CH3	CH2	CH1	CH0	Playback stop command. Can be specified for each channel.
MUON	0	1	1	1	CH3	CH2	CH1	CH0	Silence insertion command.

Command	D7	D6	D5	D4	D3	D2	D1	D0	Description
	M7	M6	M5	M4	M3	M2	M1	M0	Use the data of the 2nd byte to specify the length of silence. Can be specified for each channel.
SLOOP	1	0	0	0	CH3	CH2	CH1	CH0	Repeat playback mode setting command. The setting is enabled during playback. Can be specified for each channel.
CLOOP	1	0	0	1	CH3	CH2	CH1	CH0	Repeat playback mode release command. When the STOP command is input, repeat playback mode is released automatically. Can be specified for each channel.
CVOL	1	0	1	0	CH3	CH2	CH1	CH0	Volume setting command. Use the data of the 2nd byte to specify volume. Can be specified for each channel.
	—	—	—	CV4	CV3	CV2	CV1	CV0	
RDSTAT	1	0	1	1	0	0	0	ERR	Status serial read command. This command reads the command status and the status of the fail safe function for each channel.
OUTSTAT	1	1	0	0	0	BUSY/NCR	C1	C0	Status output command. This command outputs the command status of each channel from the STATUS pin.
SAFE	1	1	0	1	0	0	0	0	Fail safe setting command. Sets settings for power supply voltage detection, temperature detection, and monitoring time.
	TM2	TM1	TM0	TSD1	TSD0	BLD2	BLD1	BLD0	
ERCL	1	1	1	1	1	1	1	1	This command clears error while the fail safe function is operating.

Description of Command Functions

1. PUP command

• command

0	0	0	0	0	0	0	WCM
---	---	---	---	---	---	---	-----

The PUP command is used to shift the ML22Q553 from a power down state to a command waiting state. The ML22Q553 can only accept the PUP command while it is in a power down state. Therefore, in a power down state, the device will ignore any other command if entered.

The ML22Q553 enters a power down state under any of the following conditions:

- 1) When power is turned on
- 2) At RESETB input
- 3) When CBUSYB go to a “H” level after inputting the power down command

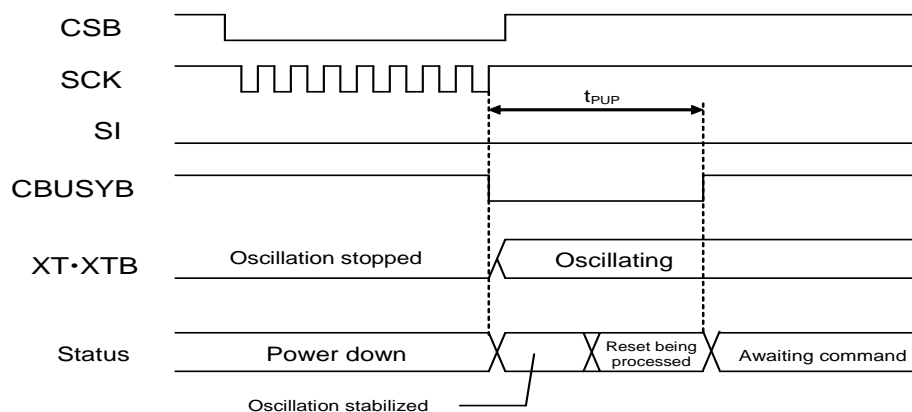

The WCM bit is used to set the two-time command input mode. When set to "1", the command input thereafter will be processed in two-time command input mode and becomes valid only when the first data input matches the second one.

WCM	Two-time command input mode
0	No (initial value)
1	Yes

The regulator starts operating after the PUP command is entered. Any command will be ignored if entered while oscillation is stabilized. However, if a “L” level is input to the RESETB pin, the LSI enters a power down state immediately.

Neither line output nor speaker output is enabled by the PUP command. Power up the analog section by the AMODE command.

2. AMODE command

• command	0	0	0	0	0	1	HPF1	HPF0	1st byte
	0	DAG1	DAG0	AIG1	AIG0	DAEN	SPEN	POP	2nd byte

The AMODE command is used to configure various settings for the analog section.

If the PDWN command is input while the analog section is in the power-up state, the analog section enters a power down state under the setting conditions that were in effect when the analog section was powered up by the AMODE command. To perform a power-down operation using different conditions from those used at analog section power-up, set settings by the AMODE command.

To change the setting of DAEN/SPEN while the analog section is in the power-up state, first put the analog section into the power-down state and then put the analog section into the power-up state again by the AMODE command.

The detailed command settings are shown below.

Each setting is initialized upon reset release or by the PUP command.

Don't input the STOP command during the AMODE command is being processed (CBUSYB="L").

Input the AMODE command for analog section into the power-down state before the PDWN command is input.

The HPF1/HPF0 bits set the cut-off frequency of the HPF.

HPF1	HPF0	Cut-off frequency
0	0	Off (initial value)
0	1	200 Hz
1	0	300 Hz
1	1	400 Hz

The POP bit specifies whether to suppress generation of "pop" noise.

- If the bit is "0" (no pop noise suppression) and the DAEN bit is "1", the LINE output rises from the DGND level to the SG level in about 35 ms, at which time the analog section enters the power-up state. If the DAEN bit is "0", the LINE output falls from the SG level to the DGND level in about 110 ms, at which time the analog section enters the power down state.
- If the bit is "1" (with pop noise suppression) and the DAEN bit is "1", the LINE output rises from the DGND level to the SG level in about 90 ms, at which time the analog section enters the power-up state. If the DAEN bit is "0", the LINE output falls from the SG level to the DGND level in about 140 ms, at which time the analog section enters the power down state.

POP	Pop noise suppression
0	No (initial value)
1	Yes

- When powering up the speaker amplifier
Setting values: POP bit = "0", DAEN and SPEN bits = "0" → "1"

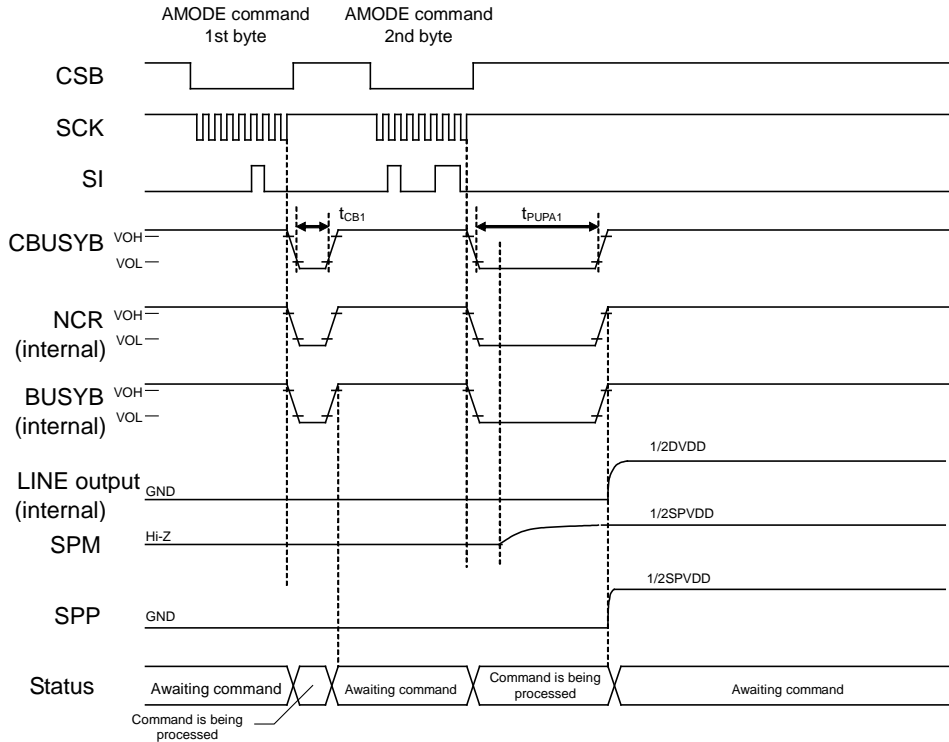

- When powering up the line amplifier (with pop noise suppression)
Setting values: POP bit = "1", DAEN bit = "0" → "1" (SPEN bit = "0")

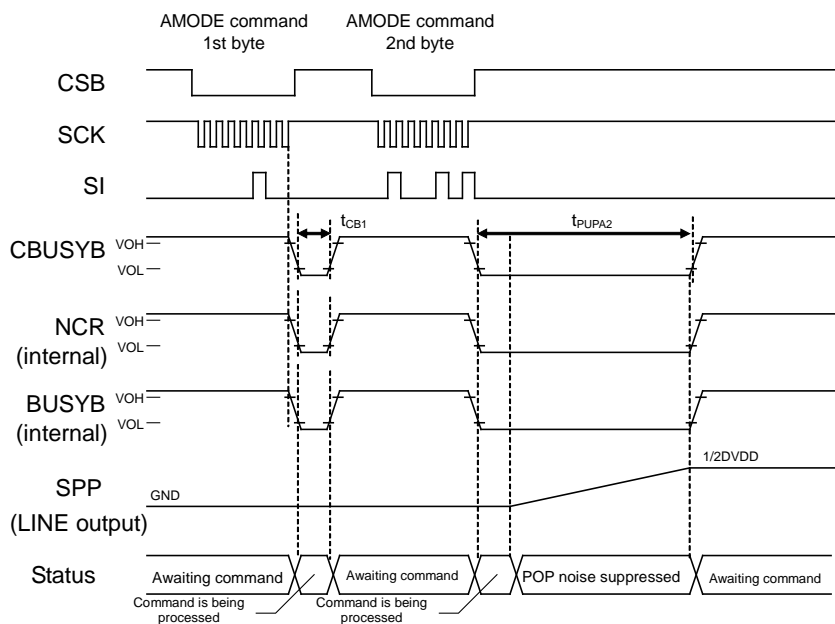

- When powering up the line amplifier (without pop noise suppression)
Setting values: POP bit = "0", DAEN bit = "0" → "1" (SPEN bit = "0")

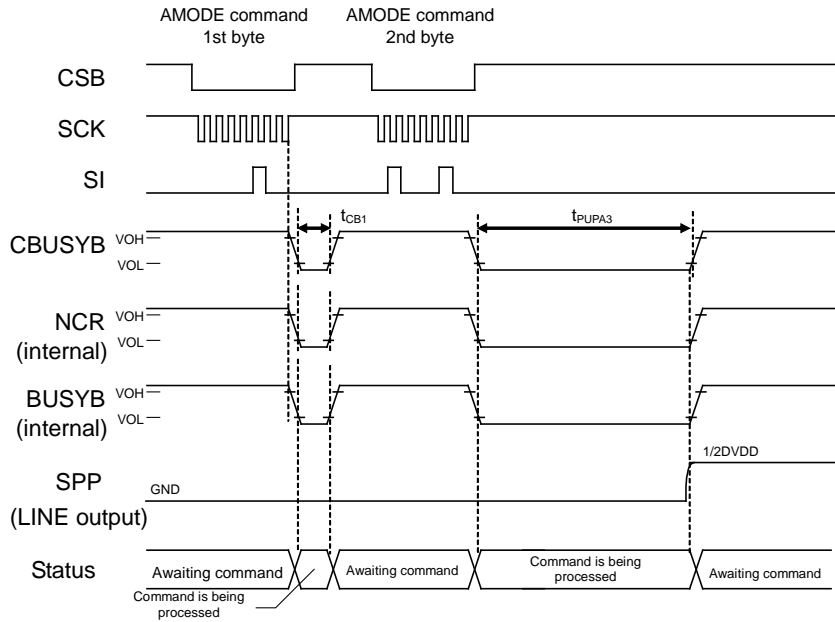

- When putting the speaker amplifier into the power down state
Setting values: POP bit = "0", DAEN and SPEN bits = "1" → "0"

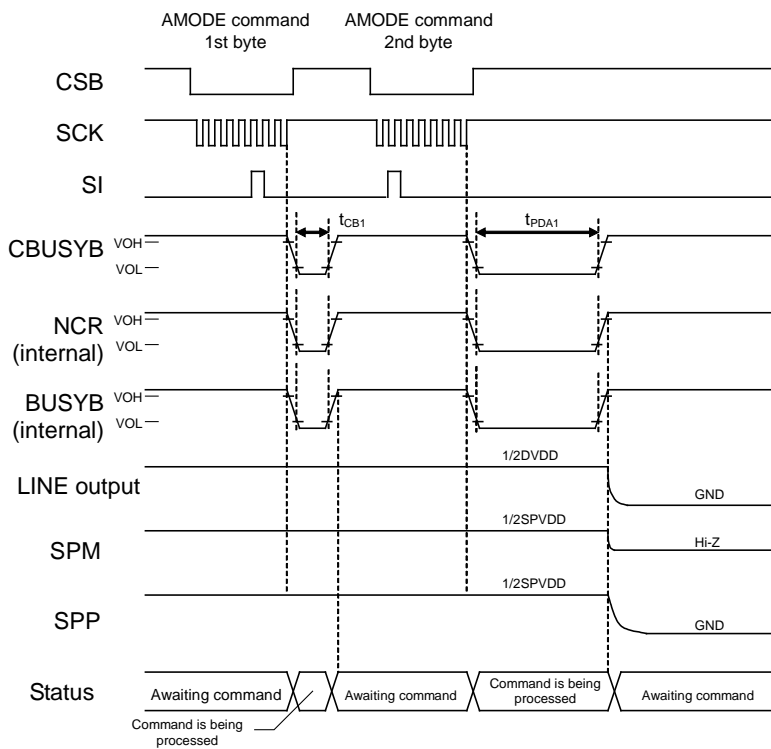

- When putting the line amplifier into the power down state (with pop noise suppression)
Setting values: POP bit = "1", DAEN bit = "1" → "0" (SPEN bit = "0")

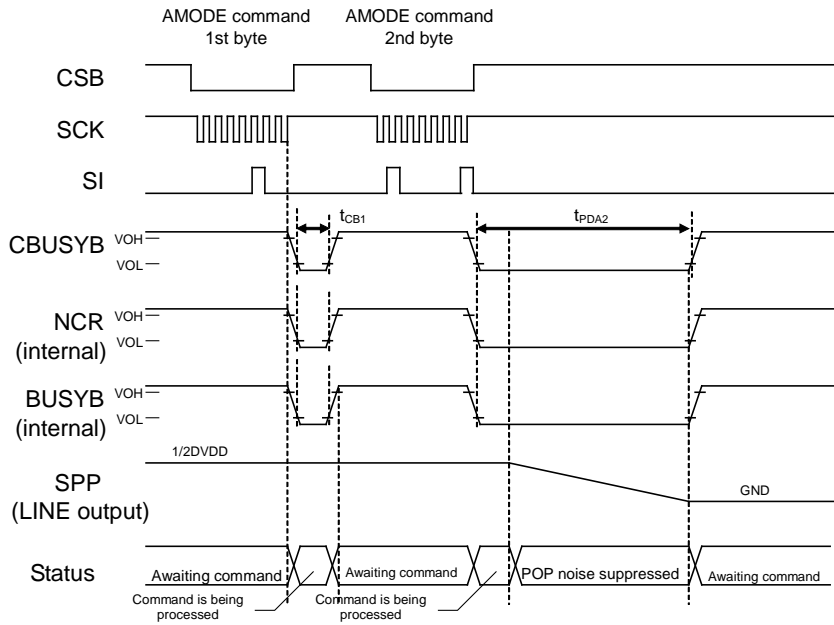

- When putting the line amplifier into the power down state (without pop noise suppression)
Setting values: POP bit = "0", DAEN bit = "1" → "0" (SPEN bit = "0")

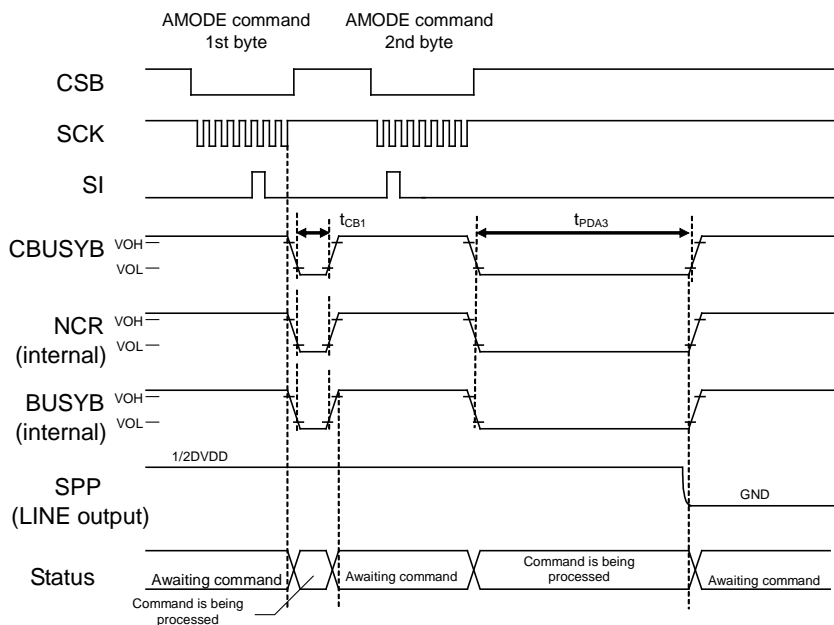

The DAG1,0 bits are used to set the gain of the internal DAC signal. The AIG1,0 bits are used to set the gain of an analog signal from the AIN pin. DAG1,0 and AIG1,0 are only enabled when the speaker amplifier is used.

DAG1	DAG0	Volume
0	0	Input OFF
0	1	Input ON (-6 dB)
1	0	Input ON (0 dB) (initial value)
1	1	Input ON (0 dB) (Setting prohibited)

AIG1	AIG0	Volume
0	0	Input OFF (initial value)
0	1	Input ON (-6 dB)
1	0	Input ON (0 dB)
1	1	Input ON (0 dB) (Setting prohibited)

Input the analog signal from the AIN pin after the AMODE command (CBUSYB="H").

The DAEN bit takes power-up and power-down control of the DAC section.

DAEN	Status of the DAC section
0	Power-down state (initial value)
1	Power-up state

The SPEN bit takes power-up and power-down control of the speaker section.

When the SPEN bit = "0", the SPP pin is configured as a LINE output.

SPEN	Status of the speaker section
0	Power-down state (initial value)
1	Power-up state

Relationship between DAEN, SPEN, and POP signals and the analog section

DAEN	SPEN	POP	Mode	Status
0	0	0	At speaker output	Power-down (initial value)
			At LINE output	Power-down (without pop noise suppression)
0	0	1	At speaker output	Power-down
			At LINE output	Power-down (with pop noise suppression)
—	1	—	Speaker output	DAC/speaker power-up
1	0	0	LINE output	DAC power-up (without pop noise suppression)
1	0	1	LINE output	DAC power-up (with pop noise suppression)

Pin status during power down

The status of each output pin during power down by the AMODE command is shown below.

Analog output pin	State
V _{DDL}	DGND
V _{DDR}	DGND
SG	DGND
SPM	Hi-Z
SPP	DGND

3. AVOL command

• command	0	0	0	0	1	0	0	0	1st byte
	0	0	AV5	AV4	AV3	AV2	AV1	AV0	2nd byte

The AVOL command is used to adjust the volume of the speaker amplifier. It is possible to input the AVOL command regardless of the status of the NCR signal.

The command enables 50-level adjustment of volume, as shown in the table below. When the PUP or AMODE command is input, the value set by the AVOL command is initialized (0 dB).

AV5-0	Volume	AV5-0	Volume
3F	+12dB	1F	-8.0
3E	+11.5	1E	-9.0
3D	+11.0	1D	-10.0
3C	+10.5	1C	-11.0
3B	+10.0	1B	-12.0
3A	+9.5	1A	-13.0
39	+9.0	19	-14.0
38	+8.5	18	-16.0
37	+8.0	17	-18.0
36	+7.5	16	-20.0
35	+7.0	15	-22.0
34	+6.5	14	-24.0
33	+6.0	11	-26.0
32	+5.5	12	-28.0
31	+5.0	11	-30.0
30	+4.5	10	-32.0
2F	+4.0	0F	-34.0
2E	+3.5	0E	OFF
2D	+3.0	0D	OFF
2C	+2.5	0C	OFF
2B	+2.0	0B	OFF
2A	+1.5	0A	OFF
29	+1.0	09	OFF
28	+0.5	08	OFF
27	+0.0 (initial value)	07	OFF
26	-1.0	06	OFF
25	-2.0	05	OFF
24	-3.0	04	OFF
23	-4.0	03	OFF
22	-5.0	00	OFF
21	-6.0	01	OFF
20	-7.0	00	OFF

4. FAD command

• command	0	0	0	0	1	1	0	0	1st byte
	0	0	0	0	FAD3	FAD2	FAD1	FAD0	2nd byte

The FAD command is used to set the fade-in time for the speaker amplifier.

The fade-in time can be adjusted through 16 levels, as shown in the table below. The initial value after reset is 298 μ s. When the PUP command is input, the value set by the FAD command is initialized (298 μ s).

FAD3-0	Fade-in time (μ s)
F	442
E	422
D	401
C	381
B	360
A	340
9	319
8	298 (initial value)
7	278
6	257
5	237
4	216
3	195
2	175
1	154
0	134

5. PDWN command

• command

0	0	1	0	0	0	0	0
---	---	---	---	---	---	---	---

The PDWN command is used to shift the ML22Q553 from a command waiting state to the power down state. However, since every setting will be initialized after entering the power down state, initial settings need to be set after power-up. This command is invalid during playback. To resume playback after the ML22Q553 has shifted to the power down state, first input the PUP and AMODE commands and then input the PLAY command.

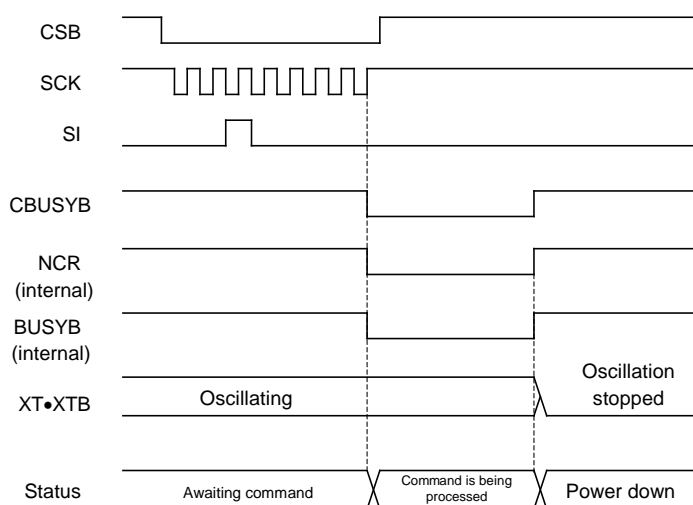

Oscillation stops after a lapse of command processing time after the PDWN command is input. The regulator stops operation after a lapse of command processing time after the PDWN command is input. At this time, the SPM output of the speaker amplifier goes into a Hi-Z state to prevent generation of pop noise.

Initial status at reset input and status during power down

The status of each output pin is as follows:

Analog output pin	State
V _{DDL}	DGND
V _{DDR}	DGND
SG	DGND
SPM	Hi-Z
SPP	DGND

6. FADR command

• command

0	0	1	1	C1	C0	F9	F8	1st byte
F7	F6	F5	F4	F3	F2	F1	F0	2nd byte

The FADR command is used to specify a phrase to be played. A playback channel and a playback phrase are set by this command. The FADR command can be set for each channel; however, the command cannot be input for multiple channels simultaneously. Input the FADR command with each NCR set to a "H" level.

When a playback phrase is specified for each channel, use the START command to start playback.

Since it is possible to specify a playback phrase (F9–F0) at the time of creating a ROM that stores voice data, specify the phrase that was specified when the ROM was created.

Channel settings

C1	C0	Channel
0	0	Channel 0
0	1	Channel 1
1	0	Channel 2
1	1	Channel 3

The diagram below shows the timing for specifying (F9–F0) = 02H as the phrase to play on channel 1.

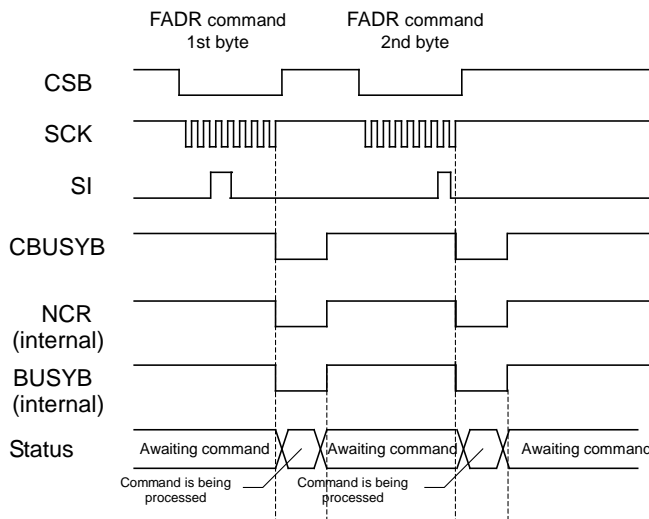

7. PLAY command

• command	0	1	0	0	C1	C0	F9	F8	1st byte
	F7	F6	F5	F4	F3	F2	F1	F0	2nd byte

The PLAY command is used to start playback with phrase specified. This command can be input when the NCR signal on the target channel is at a “H” level.

Since it is possible to specify a playback phrase (F9–F0) at the time of creating a ROM that stores voice data, specify the phrase that was specified when the ROM was created.

The figure below shows the timing of phrase (F9–F0 = 01H) playback.

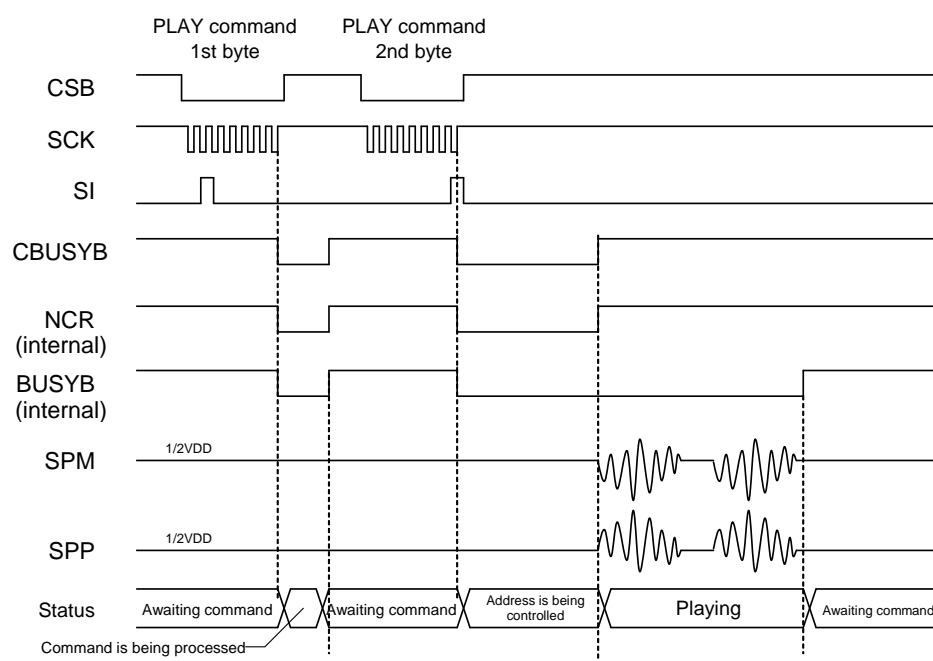

When the 1st byte of the PLAY command is input, the device enters a state awaiting input of the 2nd byte of the PLAY command after a lapse of command processing time. When the 2nd byte of PLAY command is input, after a lapse of command processing time, the device starts reading from the ROM the address information of the phrase to be played. Thereafter, playback operation starts, the playback is performed up to the specified ROM address, and then the playback terminates automatically.

The NCR signal is at a “L” level during address control, and goes “H” when the address control is finished and playback starts. When the NCR signal on the target channel goes “H”, it is possible to input the PLAY command for the next playback phrase.

During address control, the BUSYB signal is at a “L” level during playback and goes “H” when playback is finished. Whether the playback is going on can be known by the BUSYB signal.

Channel settings

C1	C0	Channel
0	0	Channel 0
0	1	Channel 1
1	0	Channel 2
1	1	Channel 3

PLAY Command Input Timing for Continuous Playback

The diagram below shows the PLAY command input timing in cases where one phrase is played and then the next phrase is played in succession.

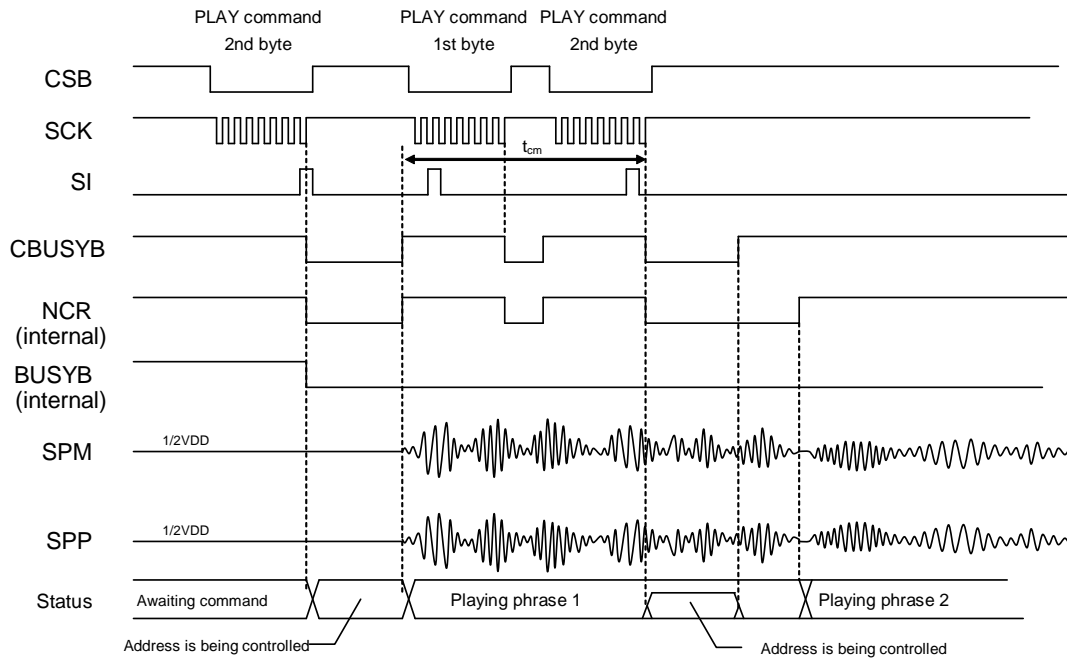

As shown in the diagram above, if performing continuous playback, input the PLAY command for the second phrase within 10 ms (t_{cm}) after the NCR signal on the target channel goes "H". Please input the following PLAY command after checking that playback is completed by the RDSTAT command, when it is not continuous playback.

8. START command

• command	0	1	0	1	CH3	CH2	CH1	CH0
-----------	---	---	---	---	-----	-----	-----	-----

The START command is a channel synchronization start (i.e., starts phrase playback on multiple channels simultaenously) command. It is necessary to specify playback phrases using the FADR command before inputting the START command. Setting any bit(s) from CH0 to CH3 to "1" starts playback on the corresponding channel(s). Input the START command with each NCR set to a "H" level.

The figure below shows the timing when starting playback on channel 00 and channel 1 simultaneously.

Channel settings

	Channel
CH0	Setting this bit to "1" starts playback on channel 0.
CH1	Setting this bit to "1" starts playback on channel 1.
CH2	Setting this bit to "1" starts playback on channel 2.
CH3	Setting this bit to "1" starts playback on channel 3.

Be sure to set the channel setting bits(CH0-CH3).

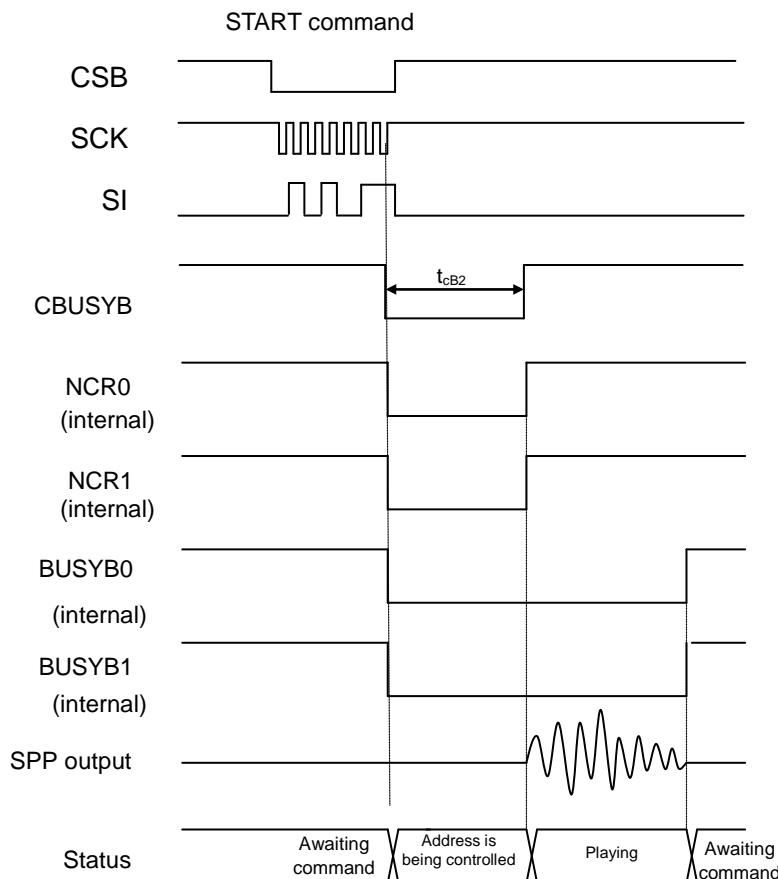

START Command Input Timing for Continuous Playback

The diagram below shows the START command input timing in cases where one phrase is played and then the next phrase is played in succession.

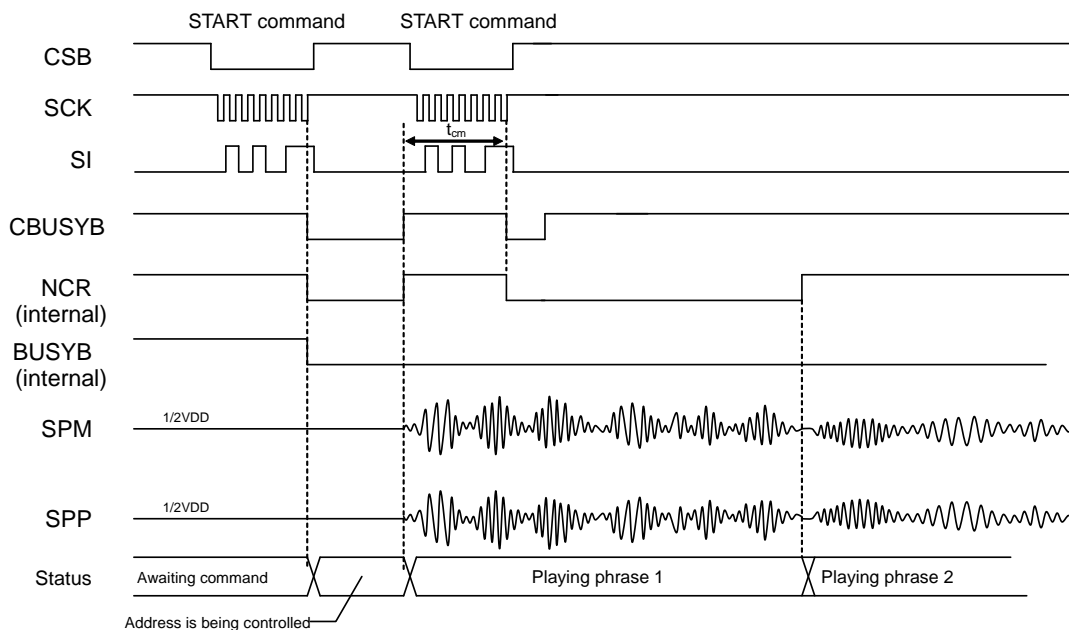

As shown in the diagram above, if performing continuous playback, input the START command for the second phrase within 10 ms (t_{cm}) after the NCR signal on the target channel goes "H". Please input the following START command after checking that playback is completed by the RDSTAT command, when it is not continuous playback.

9. STOP command

• command

0	1	1	0	CH3	CH2	CH1	CH0
---	---	---	---	-----	-----	-----	-----

The STOP command is used to stop playback. It can be set for each channel. Setting any bit(s) from CH0 to CH3 to “1” stops playback on the corresponding channel(s). If the speech synthesis processing for all channels stops, the AOUT output goes to the V_{SG} level and the NCR and BUSYB signals go to a “H” level.

Although it is possible to input the STOP command regardless of the status of NCR during playback, a prescribed command interval time needs taking.

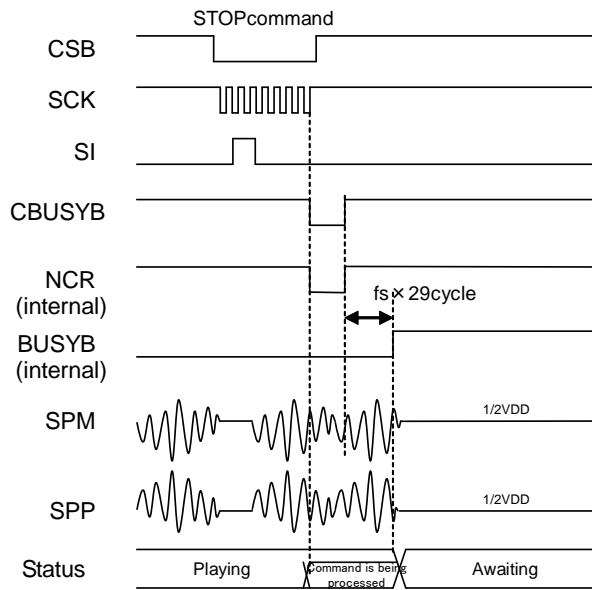

Channel settings

	Channel
CH0	Setting this bit to “1” stops playback on channel 0.
CH1	Setting this bit to “1” stops playback on channel 1.
CH2	Setting this bit to “1” stops playback on channel 2.
CH3	Setting this bit to “1” stops playback on channel 3.

Be sure to set the channel setting bits(CH0-CH3).

The STOP command allows specifying multiple channels at one time.

10. MUON command

• command	0	1	1	1	CH3	CH2	CH1	CH0	1st byte
	M7	M6	M5	M4	M3	M2	M1	M0	2nd byte

The MUON command allows inserting a silence between two playback phrases. The command can be input when the NCR signal on the target channel is at a “H” level.

Set the silence time length after inputting this command. It can be set for each channel. The MUON command allows specifying multiple channels at one time. Setting any bit(s) from CH0 to CH3 to “1” plays silence on the corresponding channel(s).

Channel settings

	Channel
CH0	Setting this bit to “1” inserts a silence on channel 0.
CH1	Setting this bit to “1” inserts a silence on channel 1.
CH2	Setting this bit to “1” inserts a silence on channel 2.
CH3	Setting this bit to “1” inserts a silence on channel 3.

Be sure to set the channel setting bits(CH0-CH3).

As the silence length (M7–M0), a value between 20 ms and 1024 ms can be set at 4 ms intervals (252 steps in total).

The equation to set the silence time length is shown below.

The silence length (M7–M0) must be set to 04h or higher.

$$t_{mu} = (2^7 \times (M7) + 2^6 \times (M6) + 2^5 \times (M5) + 2^4 \times (M4) + 2^3 \times (M3) + 2^2 \times (M2) + 2^1 \times (M1) + 2^0 \times (M0) + 1) \times 4ms$$

The figure below shows the timing of inserting a silence of 20 ms between the repetitions of a phrase of (F7–F0) = 01h.

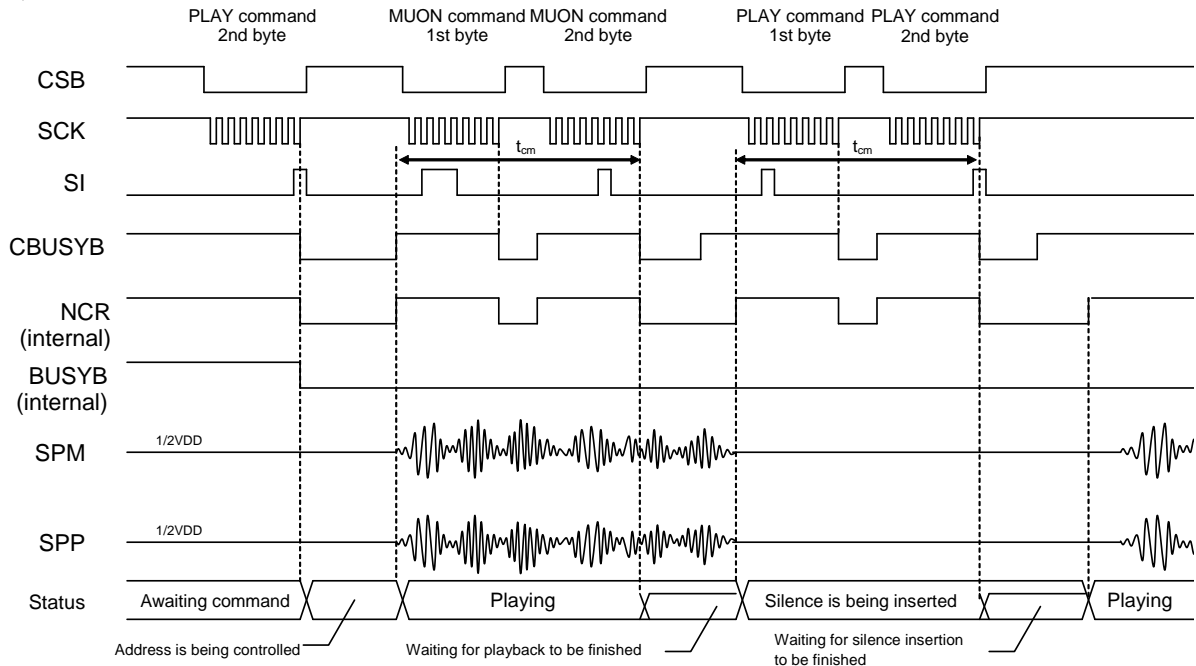

When the PLAY command is input, the address control over phrase 1 ends, the phrase playback starts, and the CBUSYB and NCR signals go to a “H” level. Input the MUON command after this CBUSYB signal changes to a “H” level. After the MUON command input, the NCR signal remains “L” until the end of phrase 1 playback, and the device enters a state waiting for the phrase 1 playback to terminate.

When the phrase 1 playback is terminated, the silence playback starts and the NCR signal goes to a “H” level. After the NCR signal has gone to a “H” level, re-input the PLAY command in order to play phrase 1.

After the PLAY command input, the NCR signal once again goes to a “L” level and the device enters a state waiting for the termination of silence playback.

When the silence playback is terminated and then the phrase 1 playback starts, the NCR signal goes “H”, and the device enters a state where it is possible to input the next PLAY or MUON command.

The BUSYB signal remains “L” until the end of a series of playback.

As shown in the diagram above, if performing continuous playback, input the MUON/PLAY/START command for the second phrase within 10 ms (t_{cm}) after the NCR signal on the target channel goes “H”. Please input the following MUON/PLAY/START command after checking that playback is completed by the RDSTAT command, when it is not continuous playback.

11. SLOOP command

• command

1	0	0	0	CH3	CH2	CH1	CH0
---	---	---	---	-----	-----	-----	-----

The SLOOP command is used to set repeat playback mode. The command can be input for each channel. The SLOOP command allows specifying multiple channels at one time. Setting any bit(s) from CH0 to CH3 to "1" repeats playback on the corresponding channel(s). Input the SLOOP command with each NCR set to a "H" level.

Channel settings

	Channel
CH0	Setting this bit to "1" repeats playback on channel 0.
CH1	Setting this bit to "1" repeats playback on channel 1.
CH2	Setting this bit to "1" repeats playback on channel 2.
CH3	Setting this bit to "1" repeats playback on channel 3.

Be sure to set the channel setting bits(CH0-CH3).

Once repeat playback mode is set, the current phrase is repeatedly played until the repeat playback setting is released by the SLOOP command or until playback is stopped by the STOP command. In the case of a phrase that was edited using the edit function, the edited phrase is repeatedly played. Following shows the SLOOP command input timing.

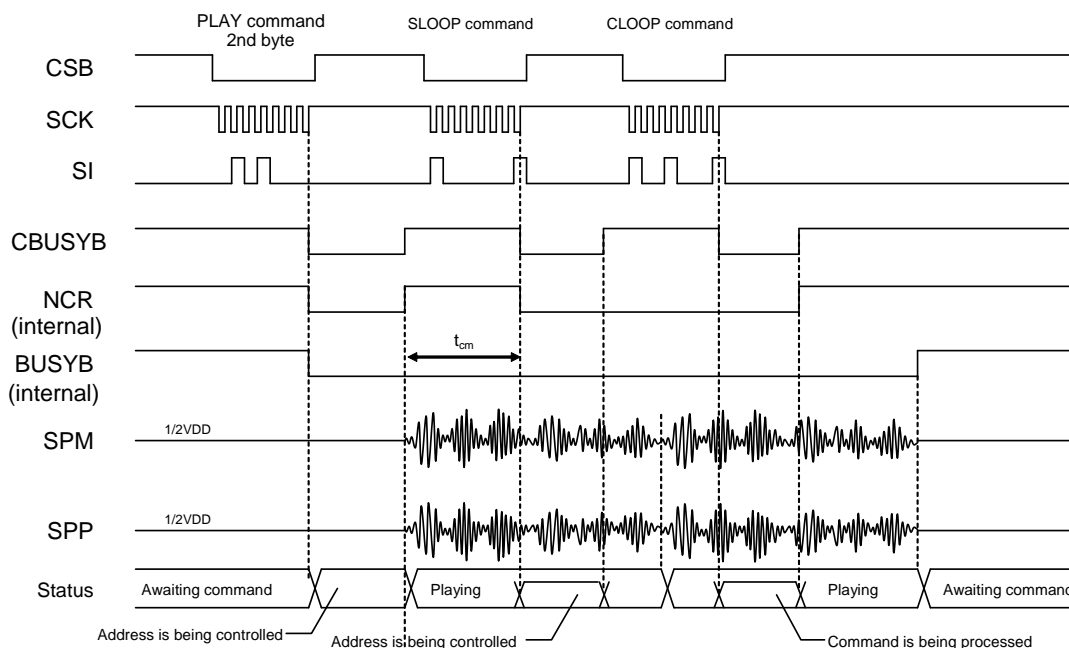

Effective Range of SLOOP Command Input

The SLOOP command is only enabled during playback. After the PLAY command is input, input the SLOOP command within 10 ms (t_{cm}) after the NCR signal on the target channel goes "H". This will enable the SLOOP command, so that repeat playback will be carried out. The NCR signal remains "L" during repeat playback mode.

12. CLOOP command

• command

1	0	0	1	CH3	CH2	CH1	CH0
---	---	---	---	-----	-----	-----	-----

The CLOOP command releases repeat playback mode. The command can be input for each channel. The CLOOP command allows specifying multiple channels at one time. Setting any bit(s) from CH0 to CH3 to “1” releases repeat playback on the corresponding channel(s). When repeat playback mode is released, the NCR signal goes “H”.

It is possible to input the CLOOP command regardless of the status of the NCR signal during playback, but a prescribed command interval needs taking.

Channel settings

	Channel
CH0	Setting this bit to “1” releases repeat playback on channel 0.
CH1	Setting this bit to “1” releases repeat playback on channel 1.
CH2	Setting this bit to “1” releases repeat playback on channel 2.
CH3	Setting this bit to “1” releases repeat playback on channel 3.

Be sure to set the channel setting bits(CH0-CH3).

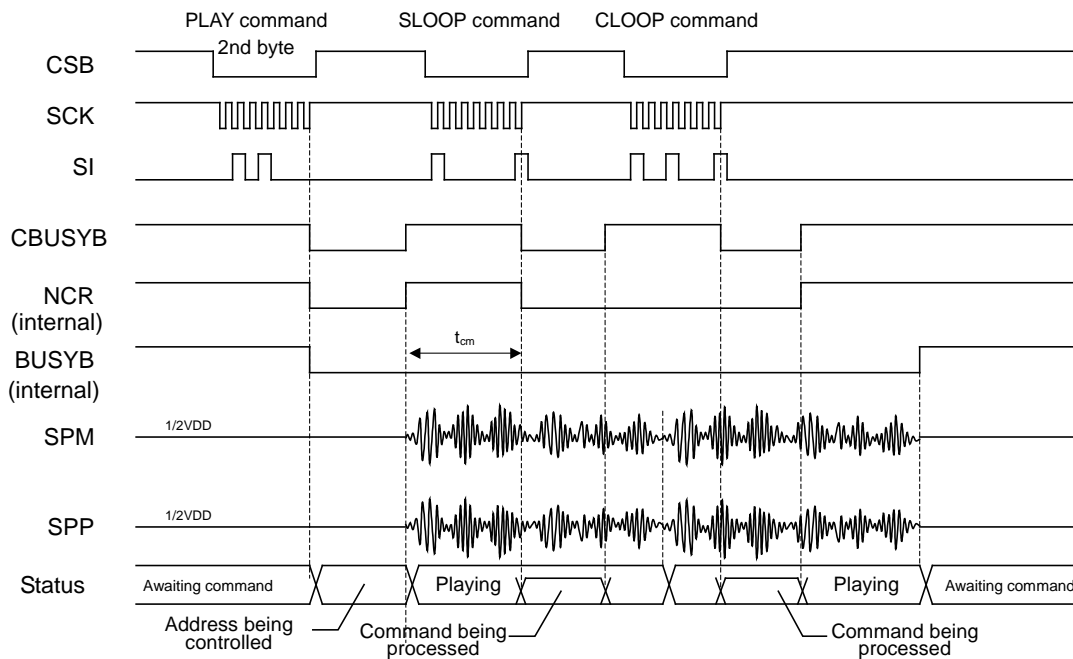

13. CVOL command

• command	1	0	1	0	CH3	CH2	CH1	CH0	1st byte
	0	0	0	CV4	CV 3	CV 2	CV 1	CV 0	2nd byte

The CVOL command is used to adjust the playback volume on each channel. It is possible to input the VOL command regardless of the status of the NCR signal.

The CVOL command can be set for each channel. The CVOL command allows specifying multiple channels at one time. Setting any bit(s) from CH0 to CH3 to “1” sets the playback volume on the corresponding channel(s). The volume setting is initialized by the AMODE command.

Channel settings

	Channel
CH0	Setting this bit to “1” sets the volume on channel 0.
CH1	Setting this bit to “1” sets the volume on channel 1.
CH2	Setting this bit to “1” sets the volume on channel 2.
CH3	Setting this bit to “1” sets the volume on channel 3.

Be sure to set the channel setting bits(CH0-CH3).

The command enables 32-level adjustment of volume, as shown in the table below. The initial value after reset release is set to 0 dB. Upon reset release or when the PUP command is input, the values set by the CVOL command are initialized.

CV4-0	Volume	CV4-0	Volume
1F	0 dB (initial value)	0F	-6.31
1E	-0.28	0E	-6.90
1D	-0.58	0D	-7.55
1C	-0.88	0C	-8.24
1B	-1.20	0B	-9.00
1A	-1.53	0A	-9.83
19	-1.87	09	-10.74
18	-2.22	08	-11.77
17	-2.59	07	-12.93
16	-2.98	06	-14.26
15	-3.38	05	-15.85
14	-3.81	04	-17.79
13	-4.25	03	-20.28
12	-4.72	02	-23.81
11	-5.22	01	-29.83
10	-5.74	00	OFF

14. RDSTAT command

• command

1	0	1	1	0	0	0	ERR
---	---	---	---	---	---	---	-----

The RDSTAT command enables reading the status of internal operation. It is possible to input the CLOOP command regardless of the status of the NCR signal during playback, but a prescribed command interval needs taking.

The ERR bit selects reading the playback status for each channel or reading the status of the fail-safe function. Keep the SI pin to “L” when read the status.

ERR	Content of data to read
0	NCR and BUSYB signals for each channel (Initial value)
1	Status of the fail-safe function

If the ERR bit is set to “0”, the following status will be read:

Output bit	D7	D6	D5	D4	D3	D2	D1	D0
Output data	BUSYB3	BUSYB2	BUSYB1	BUSYB0	NCR3	NCR2	NCR1	NCR0

When the ERR bit = “0”, the NCR and BUSYB signals of each channel are read. The NCR signal outputs a “L” level while this LSI is performing command processing and goes to a “H” level when the LSI enters a command waiting state. The BUSY signal outputs a “L” level during voice playback. The table below shows the contents of each data output at a status read.

	Output status signal
BUSY3	Channel 3 BUSYB output
BUSY2	Channel 2 BUSYB output
BUSY1	Channel 1 BUSYB output
BUSY0	Channel 0 BUSYB output
NCR3	Channel 3 NCR output
NCR2	Channel 2 NCR output
NCR1	Channel 1 NCR output
NCR0	Channel 0 NCR output

If the ERR bit is set to “1”, the following status will be read:

Output bit	D7	D6	D5	D4	D3	D2	D1	D0
Output data	0	0	0	0	0	TSDERR	BLDERR	WCMERR

When the ERR bit = “1”, the status of each fail-safe function is read. If any of the following three fail-safe functions is activated, the ERR pin is set to a “H” level and the corresponding error bit is set to “1”. If the ERR pin is set to a “H” level, check the error contents using the RDSTAT command and take appropriate measures.

Error signal	Error contents
TSDERR	High temperature error bit. This bit is set to “1” if the temperature of the LSI reaches or exceeds the temperature set by the SAFE command. For details see the section on the SAFE command.
BLDERR	Power supply voltage error bit. This bit is set to “1” if the power supply voltage level reaches or falls below the voltage set by the SAFE command. For details see the section on the SAFE command.
WCMERR	Command transfer error bit. This bit is set to “1” if a transfer error occurs in two-time command input mode.

If the ERR bit is set to “1”, the following status will be read

Output bit	D7	D6	D5	D4	D3	D2	D1	D0
OutPut data	0	0	0	SPMERR	SPPERR	TSDERR	BLDERR	WCMERR

When the ERR bit=“1”, the state of five fail-safe Function is read.

If any of fail-safe function is activated,the ERR pin is set to a “H” level and the corresponding error bit is set to “1”. If the ERR pins set to a “H” level,

check the error contents using the RDSTAT command and take appropriate measures.

ERR bit is cleared by ERCL command

Error signal	Error contents
SPMERR	SPM pin short error bit. This bit is set to “1” if the SPM pin is short to SPP pin or GND
SPPERR	SPP pin short error bit This bit is set to “1” if the SPP pin is short to SPM pin or GND
TSDERR	High temperature error bit. This bit is set to “1” if the temperature of the LSI reaches or exceeds the temperature set by the SAFE command. For details see the section on the SAFE command.
BLDERR	Power supply voltage error bit. This bit is set to “1” if the power supply voltage level reaches or falls below the voltage set by the SAFE command. For details see the section on the SAFE command.
WCMERR	Command tansfer erro bit. This bit is set to “1” if a transfer error occurs in two-time command input mode.

If the ERR bit is set to “1”, the following status will be read

Output bit	D7	D6	D5	D4	D3	D2	D1	D0
OutPut data	0	0	0	SPMERR	SPPERR	TSDERR	BLDERR	WCMERR

When the ERR bit=“1”, the state of five fail-safe functions is read. If any of fail-safe function is activated, the ERR pin is set to a “H” level and the corresponding error bit is set to “1”. If the ERR pins set to a “H” level, check the error contents using the RDSTAT command and take appropriate measures. ERR bit is cleared by ERCL command

Error signal	Error contents
SPMERR	SPM pin short error bit. This bit is set to “1” if the SPM pin is short to SPP pin or GND
SPPERR	SPP pin short error bit This bit is set to “1” if the SPP pin is short to SPM pin or GND
TSDERR	High temperature error bit. This bit is set to “1” if the temperature of the LSI reaches or exceeds the temperature set by the SAFE command. For details see the section on the SAFE command.
BLDERR	Power supply voltage error bit. This bit is set to “1” if the power supply voltage level reaches or falls below the voltage set by the SAFE command. For details see the section on the SAFE command.
WCMERR	Command tansfer erro bit. This bit is set to “1” if a transfer error occurs in two-time command input mode.

15. OUTSTAT command

• command

1	1	0	0	0	BUSY/NCR	C1	C0
---	---	---	---	---	----------	----	----

The OUTSTAT command is used to output the BUSYB or NCR signal on the specified channel from the STATUS pin. It is possible to input the CLOOP command regardless of the status of the NCR signal during playback, but a prescribed command interval needs taking.

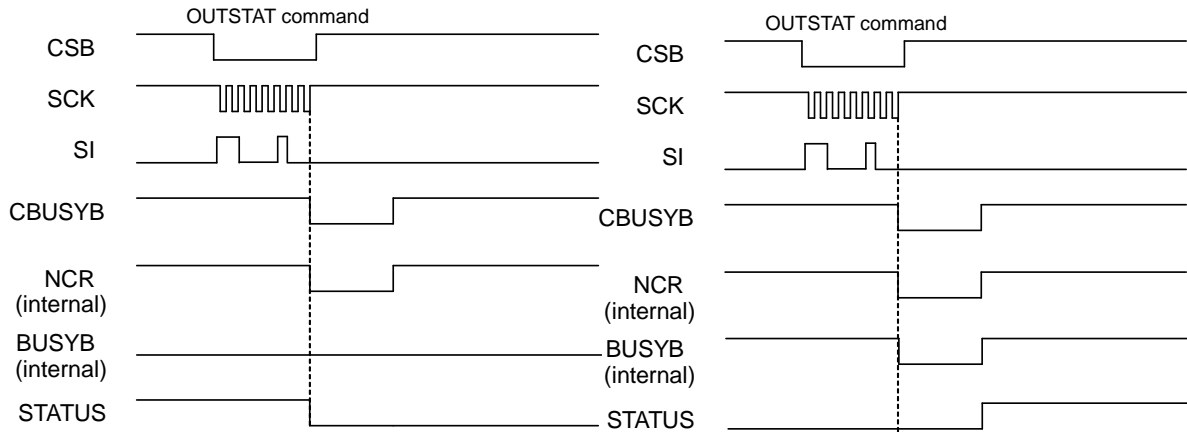

BUSY/NCR	STATUS pin status
0	Outputs the NCR signal on the specified channel.
1	Outputs the BUSYB signal on the specified channel.

Channel settings

C1	C0	Channel
0	0	Channel 0 (initial value)
0	1	Channel 1
1	0	Channel 2
1	1	Channel 3

16. SAFE command

• command

1	1	0	1	0	0	0	0
TM2	TM1	TM0	TSD1	TSD0	BLD2	BLD1	BLD0

The SAFE command is sets the settings for the low-voltage detection and temperature detection functions.

The BLD2–0 bits are used to set the power supply voltage detection level. The judgment voltage can be selected from among six levels from 2.7 to 4.0 V. The power supply voltage is monitored each time it reaches the value set by TM2–0, and if the power supply voltage reaches or falls below the set detection voltage two times or more, the ERR pin outputs a "H" level and the RDSTAT command's BLDERR bit is set to "1".

If the ERR pin is set to a "H" level, check the error contents using the RDSTAT command. If the BLDERR bit is at "1", it is possibly a power supply related failure.

BLD2	BLD1	BLD0	Judgment power supply voltage
0	0	0	OFF
0	0	1	2.7V±5% (initial value)
0	1	0	3.0V±5%
0	1	1	3.3V±5%
1	0	0	3.6V±5%
1	0	1	4.0V±5%
1	1	0	(4.0V±5%)
1	1	1	(4.0V±5%)

The TSD1–0 bits are used to set the temperature detection level. Tj=140°C or OFF can be selected as the judgment temperature. The temperature is monitored each time it reaches the value set by TM2–0, and if the temperature reaches or exceeds the set value two times or more, the ERR pin outputs a "H" level and the RDSTAT command's TSDERR bit is set to "1".

If the ERR pin is set to a "H" level, check the error contents using the RDSTAT command. If the TSDERR bit is at "1", reduce the volume using the AVOL command or put the analog section into the power down state using the AMODE command.

TSD1	TSD0	Judgment temperature (Tj)
0	0	OFF
0	1	Setting prohibited
1	0	Setting prohibited
1	1	140±10°C (initial valle,)

The judgment temperature(Tj) is 140±10°C. This LSI is beyond Tj=130°C in the operating temperature(-40°C - +150°C) depending on a operating condition and occurs by a high temperature error. The ambient temperature at that case is as follows.

Power supply(D ^{VDD} =SP ^{VDD})	Power dissipation(P _D)	Amient temperature(T _a)
4.5V	0.686W	Not detect in the operating temperature
5.0V	0.861W	detect more than 104°C
5.5V	1.055W	detect more than 98°C

* $\theta_{ja} = 31.2 [^{\circ}\text{C}/\text{W}]$ (JEDEC 2layers(refer to 67pages)), 1W/8ohm-Speaker

θ_{ja} changes by an implementation condition. The maximum ambient temperature(T_{amax}) that this LSI does not detect the high temperature error is calculated in the following expressions in using the power dissipation.

$$T_{amax} = 130[{}^{\circ}\text{C}] - \theta_{ja}[{}^{\circ}\text{C}/\text{W}] \times \text{PD}[\text{W}]$$

The maximum ambient temperature(T_{amax}) in power supply voltage 5.0V and $\theta_{ja}=36[{}^{\circ}\text{C}/\text{W}]$ is as follows.

$$T_{amax} = 130[{}^{\circ}\text{C}] - 36 \times 0.861 \doteq 99[{}^{\circ}\text{C}]$$

The TM2–0 bits are used to set the monitor interval to detect a low voltage or temperature.

TM2	TM1	TM0	Monitor interval
0	0	0	Constantly monitors
0	0	1	2 ms (initial value)
0	1	0	4 ms
0	1	1	8 ms
1	0	0	16 ms
1	0	1	32 ms
1	1	0	64 ms
1	1	1	128 ms

17. ERCL command

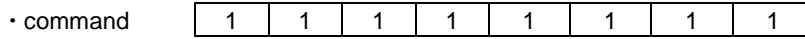

The ERCL command is used to clear an error if it occurs.

If an error occurs, a "H" level is outputted from the ERR pin. When the ERCL command is inputted, the ERR pin outputs a "L" level.

However, when the high temperature error and the power-supply voltage error continue, TSDERR of the RDSTAT command, BLDERR of the RDSTAT command and the ERR pin keep outputting "H" even if the ERCL command is inputted.

Timing diagram for when an error occurs at the time of setting the two-time command input mode

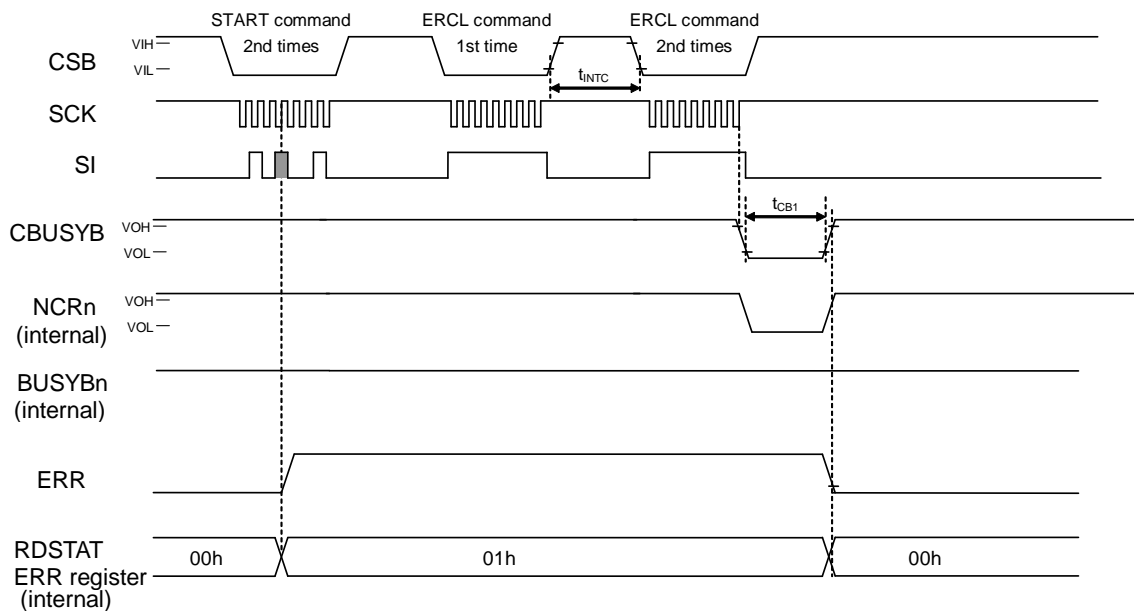

If a power supply voltage error occurs and then the power supply voltage is returned (when the SAFE command's BLD2-0 bits = 001h)

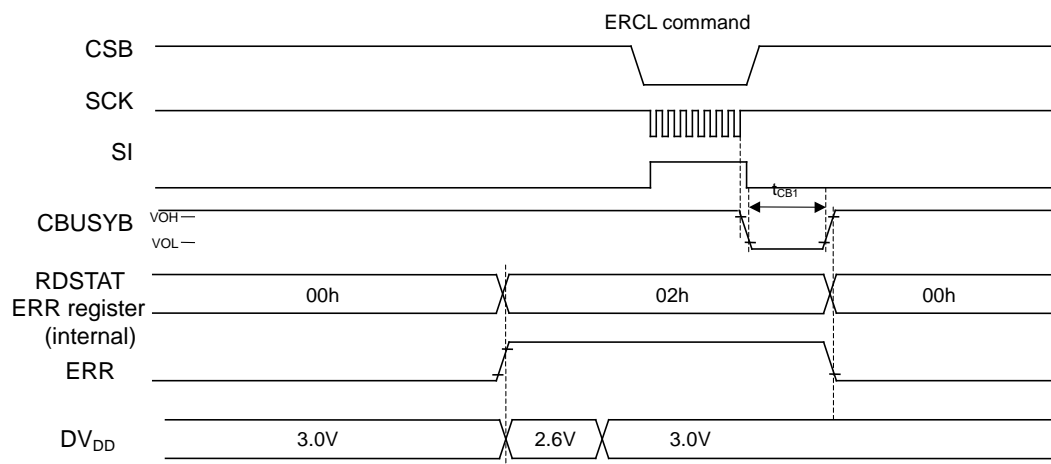

If a power supply voltage error occurs but the power supply voltage is not returned

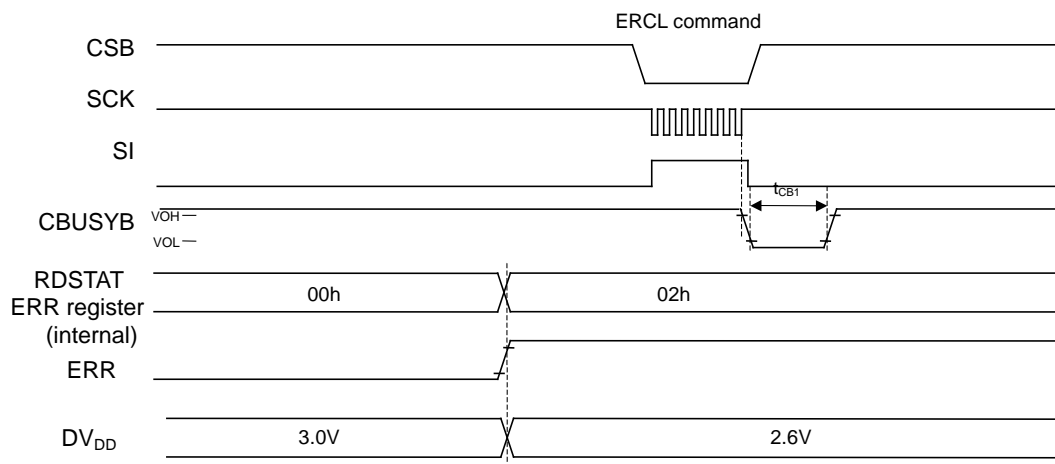

When Speaker-short situation is released before Error Clear Flow(*1)

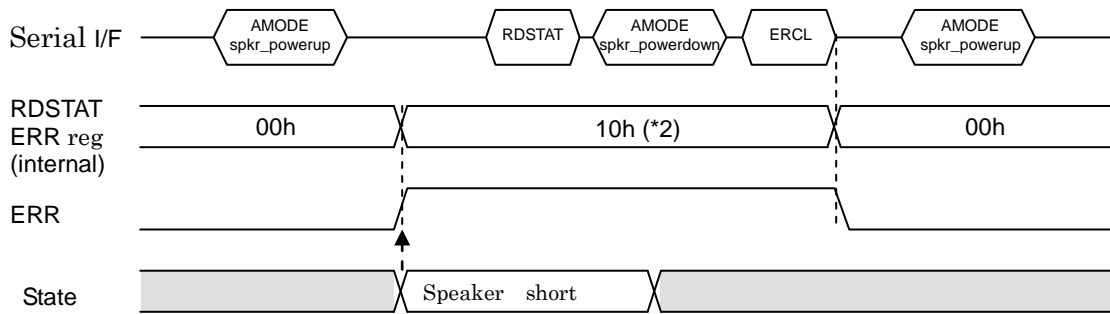

When Speaker-short situation is continued after Error Clear Flow(*1).

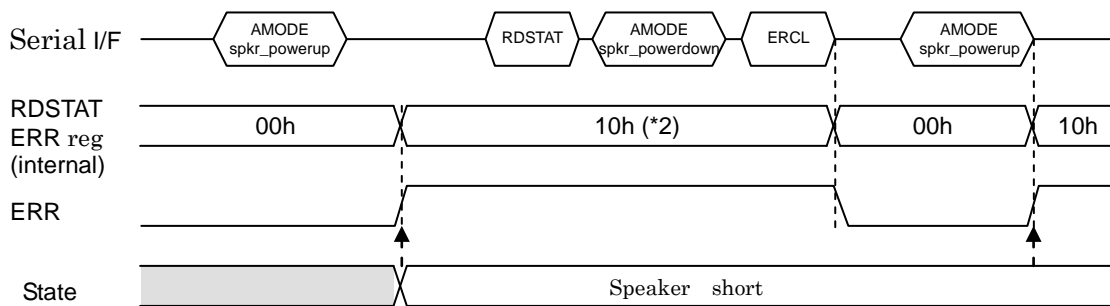

When ERCL is inputted before Error Clear Flow(*1).

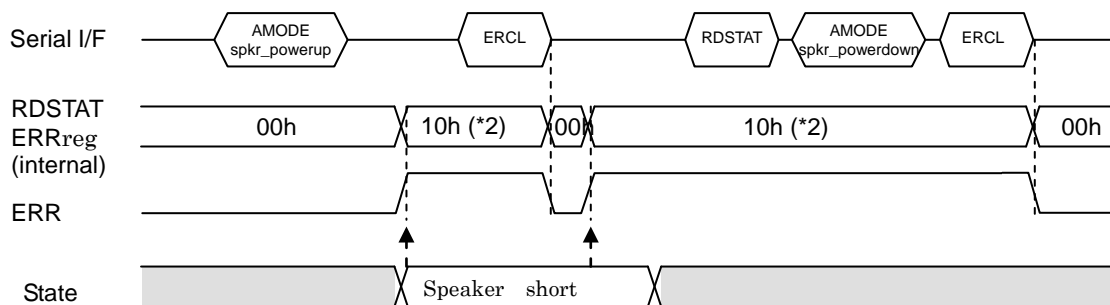

*1:Error Clear Flow:RDSTAT=>AMODE(Speaker Power-down) => ERCL

*2: SPM pin short error

Command Flow Charts

1-Byte Command Input Flow (applied to the PUP, PDWN, START, STOP, SLOOP, CLOOP, OUTSTAT, and ERCL commands)

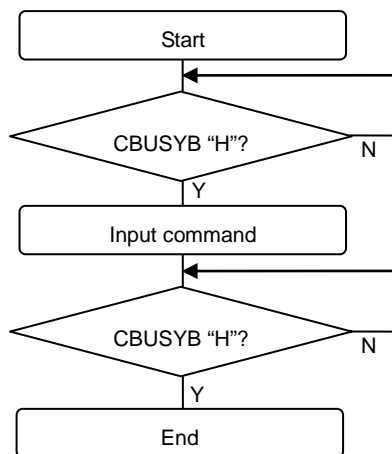

2-Byte Command Input Flow (applied to the AMODE, AVOL, FAD, FADR, PLAY, MUON, CVOL, and SAFE commands)

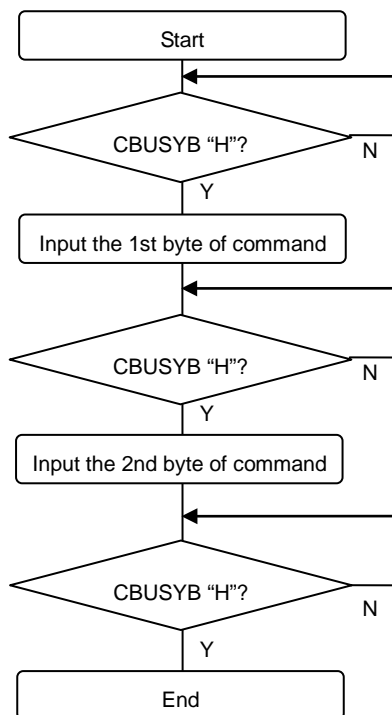

Status Read Flow

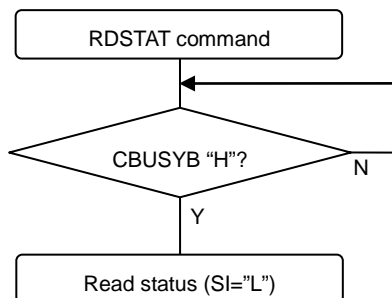

Power-On Flow

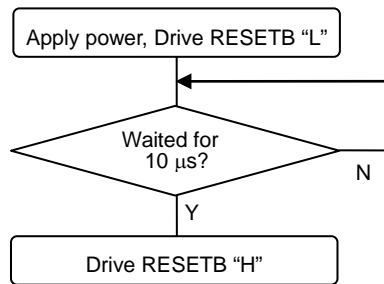

Example of Power-Up Flow

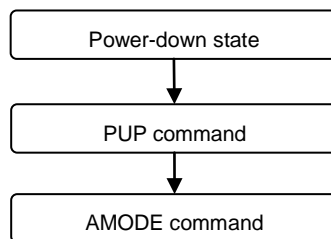

Example of Playback Start Flow

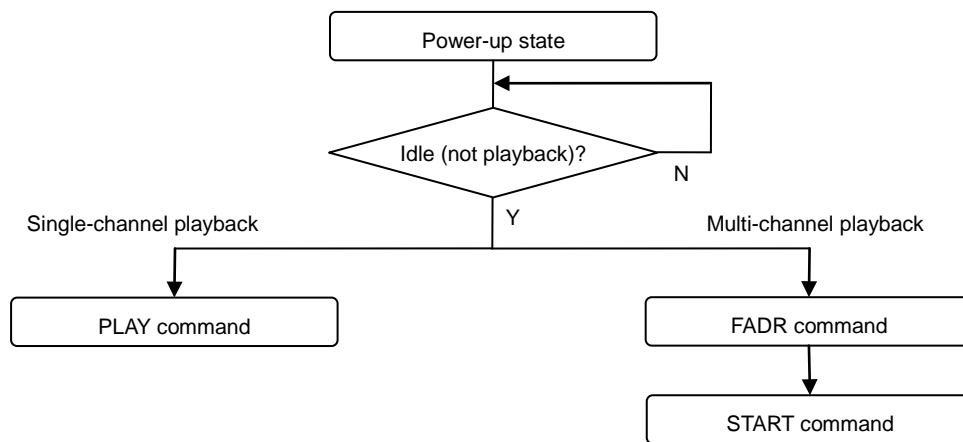

Example of Playback Stop Flow

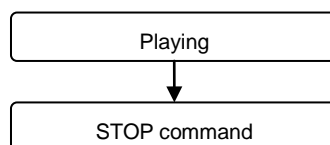

Continuous Playback Start Flow

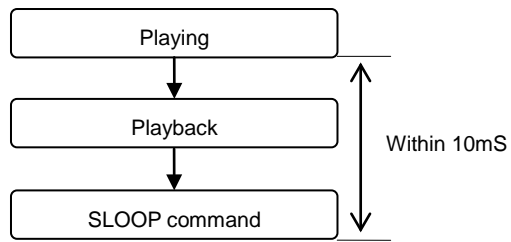

Loop Start Flow

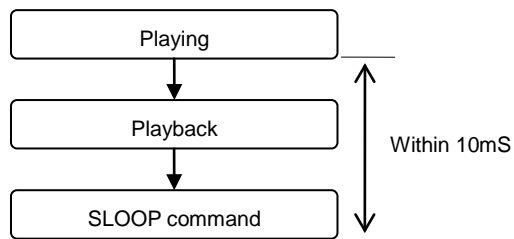

Loop Stop Flow

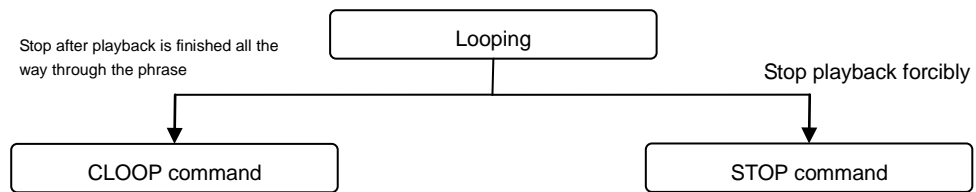

Power-Down Flow

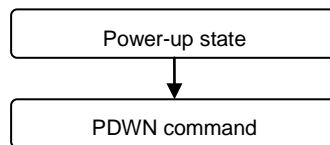

Detailed Flow of "Power-Up ⇒ Playback ⇒ Power-Down"

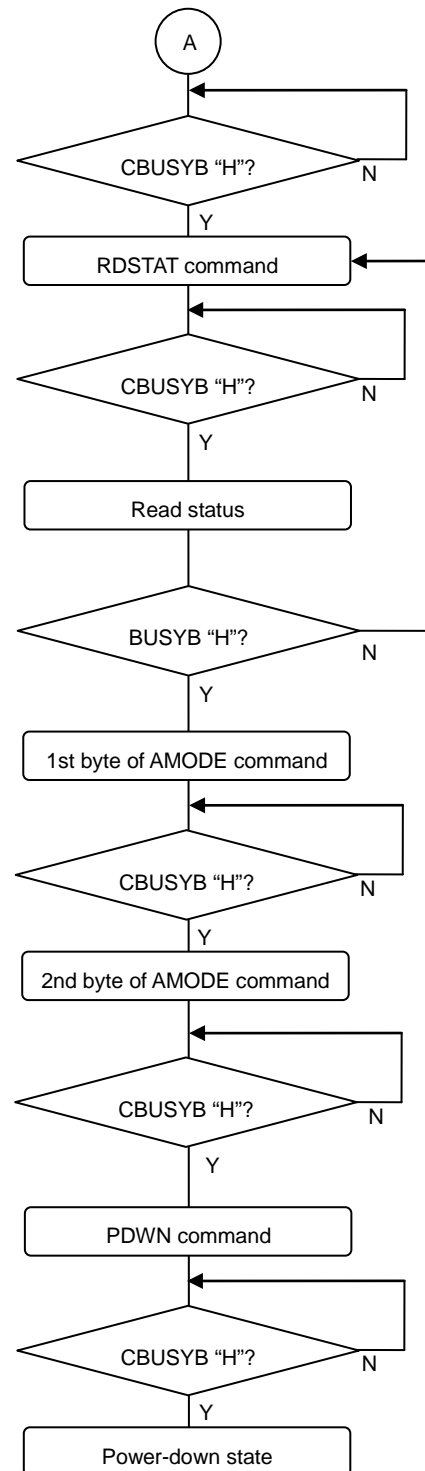
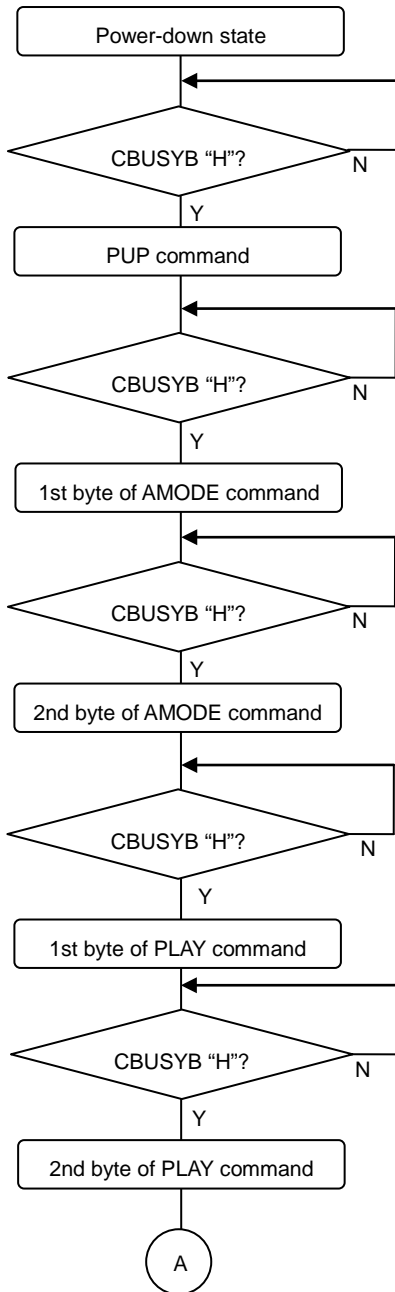

Detailed flow of "SPP/SPM Short detecting"

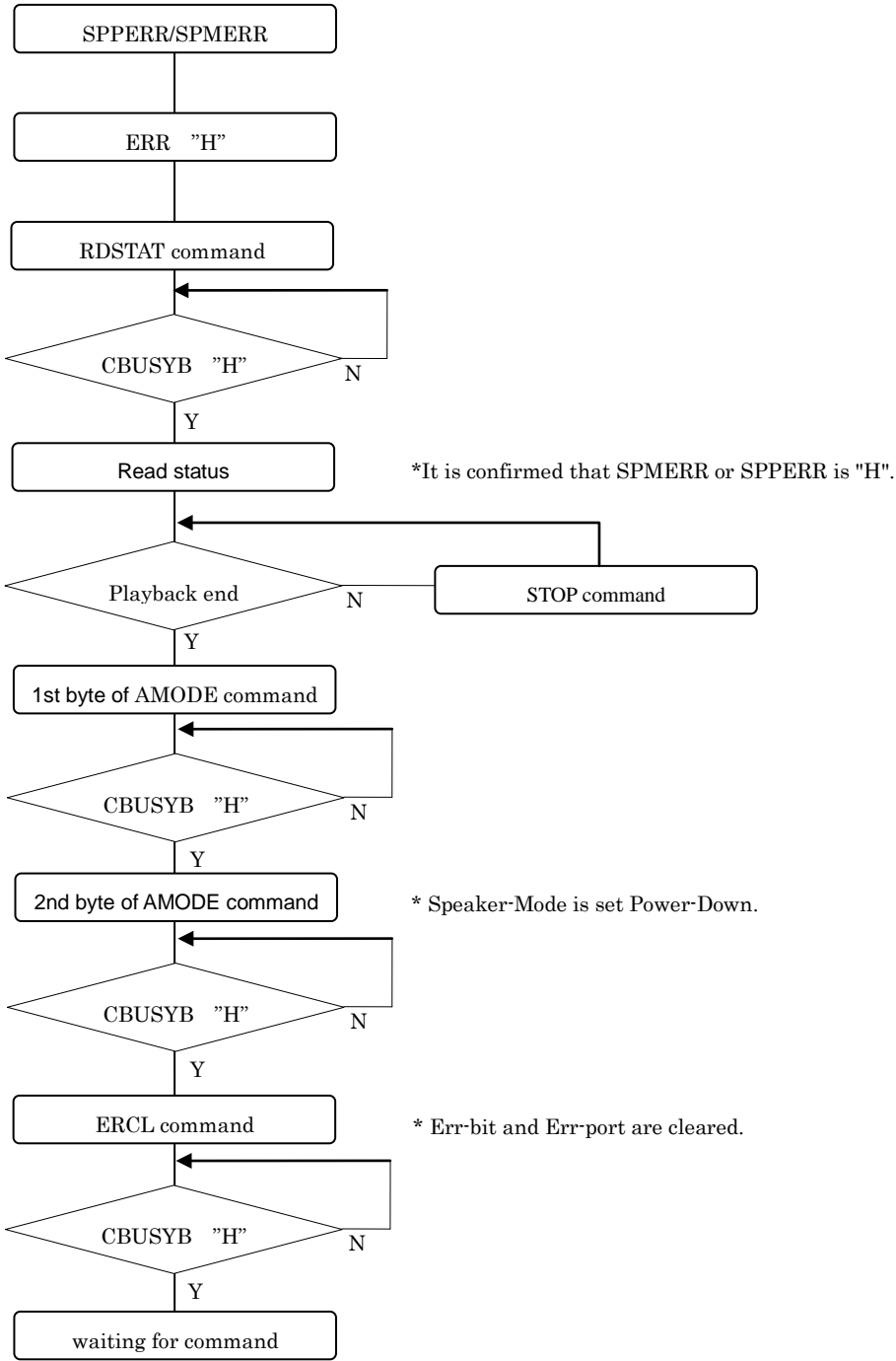

1-Byte Command input flow of two-time command input mode
(applied to the PDWN,STOP,SLOOP,CLOOP,RDSTAT,OUTSTAT,and ERCL commands)

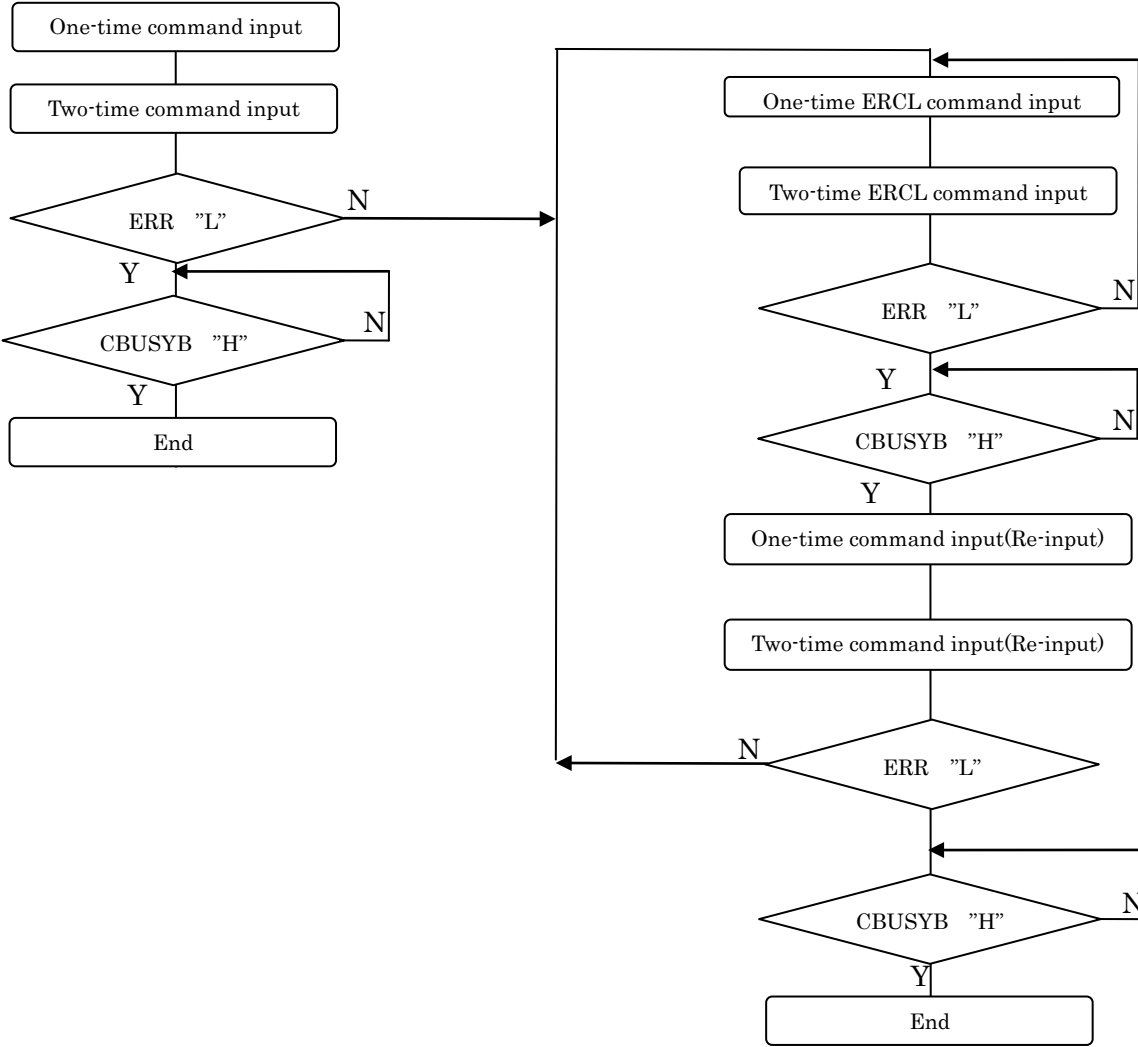

2-Byte Command input flow of two-time command input mode

(applied to the AMODE,AVOL,FAD,FADR,PLAY,MUON,CVOL, and SAFE commands)

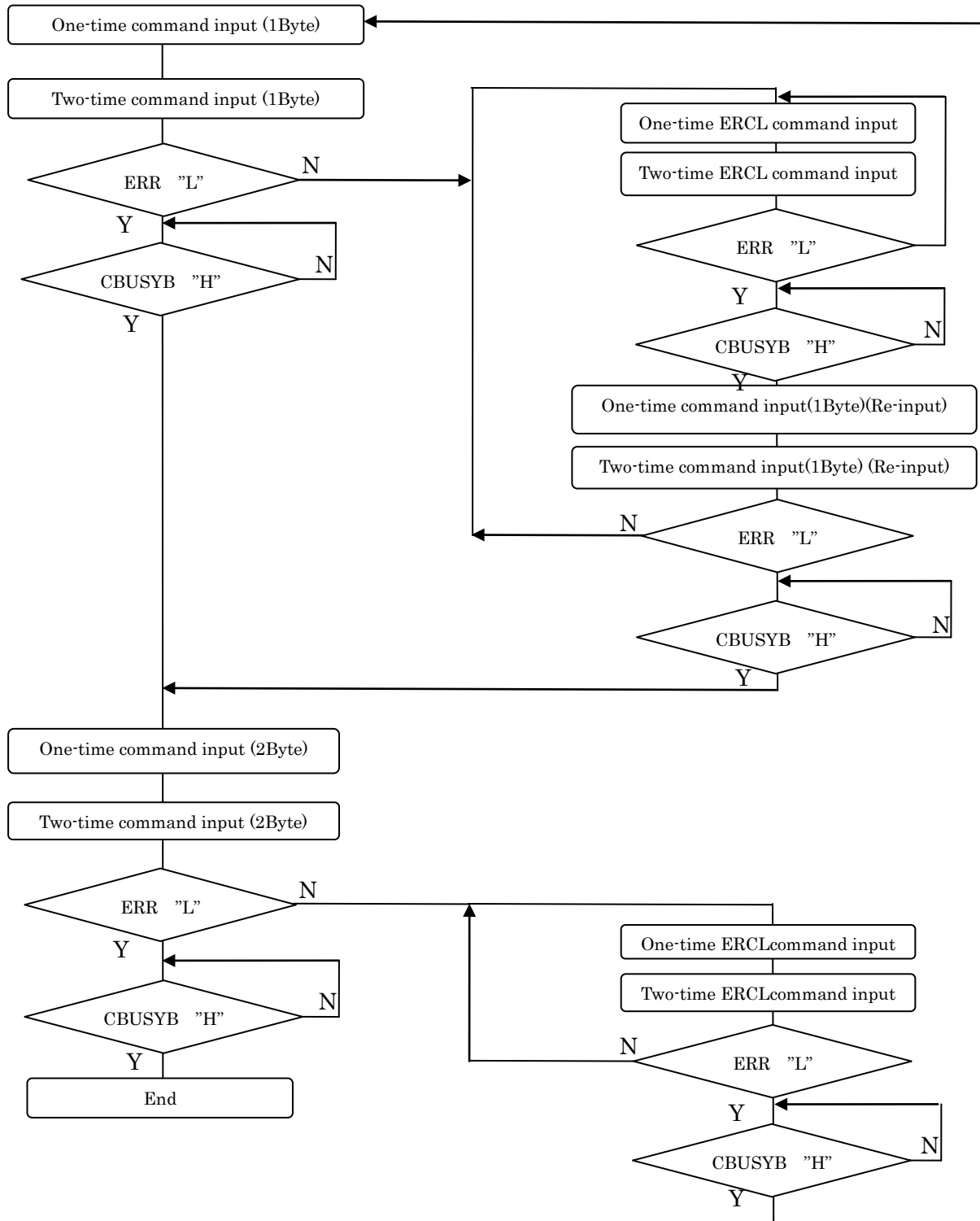

Handling of the SG Pin

The SG pin is the signal ground pin for the built-in speaker amplifier. Connect a capacitor between this pin and the analog ground so that this pin will not carry noise.

The recommended capacitance value is shown below; however, it is recommended that the user determine the capacitance value after evaluation.

Always start playback after each output voltage is stabilized.

Pin	Recommended capacitance value	Remarks
SG	0.1 μ F \pm 20%	The larger the connection capacitance, the longer the speaker amplifier output pin (SPM and SPP) voltage stabilization time.

Handling of the V_{DDL} and V_{DDR} Pins

The V_{DDL} and V_{DDR} pins are the power supply pins for the internal circuits. Connect a capacitor between each of these pins and the ground in order to prevent noise generation and power fluctuation.

The recommended capacitance value is shown below; however, it is recommended that the user determine the capacitance value after evaluation.

Always start the next operation after each output voltage is stabilized.

Pin	Recommended capacitance value	Remarks
V _{DDL} , V _{DDR}	10 μ F \pm 20%	The larger the connection capacitance, the longer the stabilization time.

Power Supply Wiring

The power supplies of this LSI are divided into the following two:

- Digital power supply (DV_{DD}) and Digital ground(DGND)
- Speaker amplifier power supply (SPV_{DD}) and Speaker amplifier ground(SPGND)

As shown in the figure below, be sure to diverge the wiring of DV_{DD} and SPV_{DD} from the root of the same power supply. DGND/SPGND is similar, too.

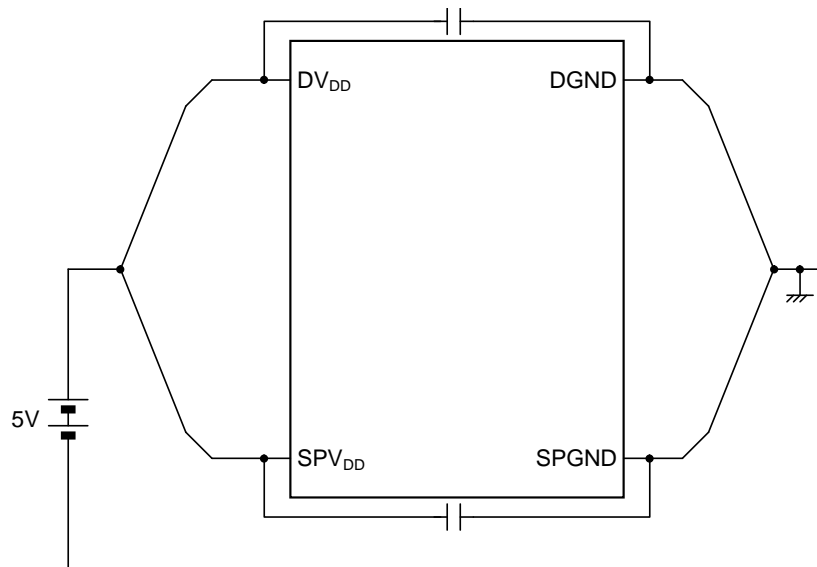

APPLICATION CIRCUIT

At using internal speaker amplifier (speaker output)

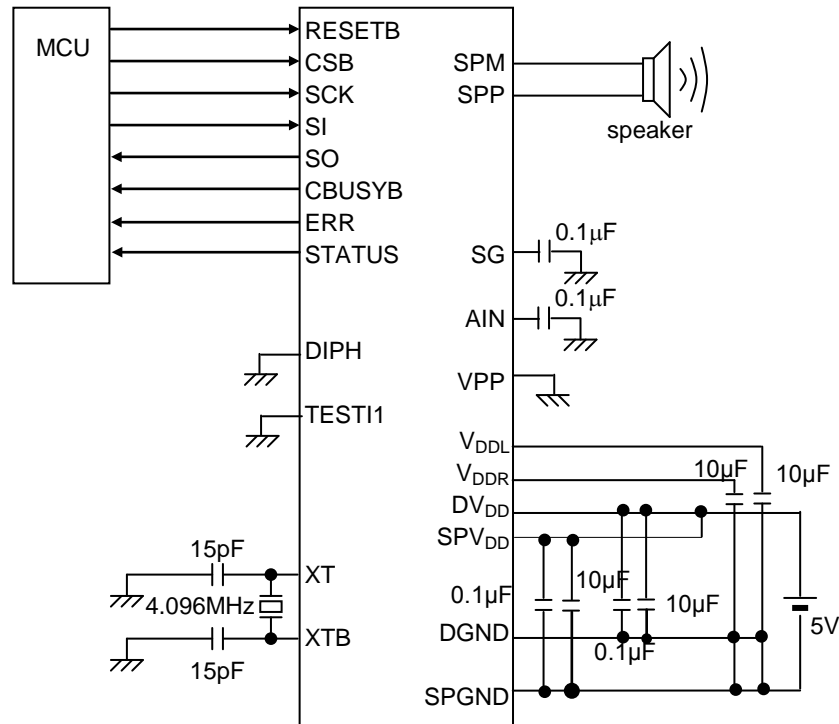

At using external speaker amplifier (line output)

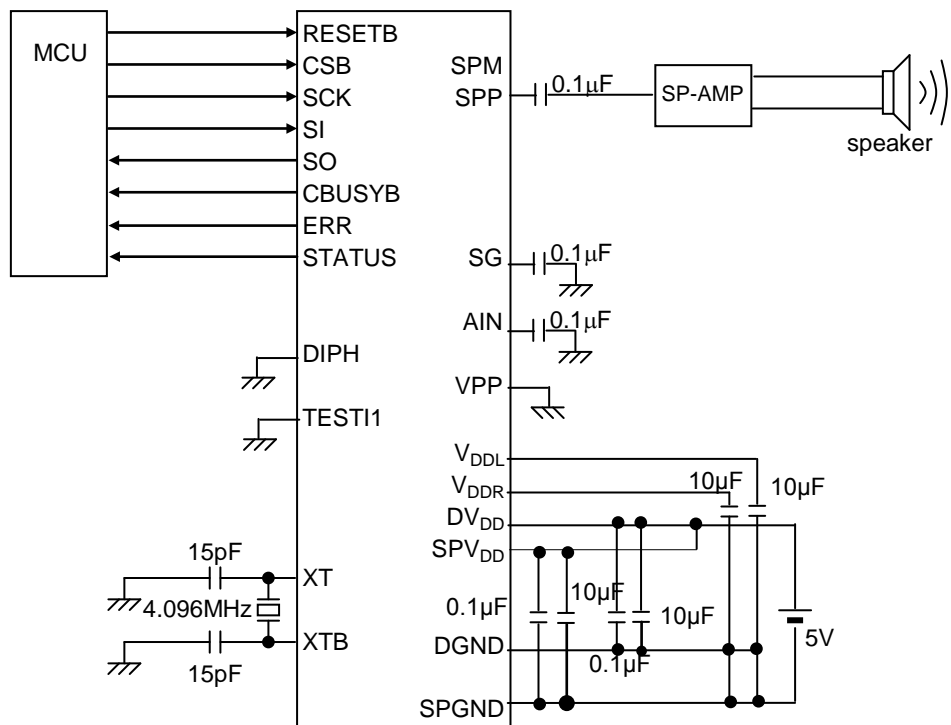

RECOMMENDED CERAMIC OSCILLATION

Recommended ceramic resonators for oscillation and conditions are shown below for reference.

KYOCERA Corporation

Freq [Hz]	Type	Optimal load capacity					
		C1 [pF]	C2 [pF]	Rf [Ohm]	Rd [Ohm]	Supply voltage Range [V]	Operating Temperature Range [°C]
4.096M	PBRV4.096MR50Y000	15(internal)		---	--	4.5 to 5.5	-40 to +125

MURATA Corporation

Freq [Hz]	Type	Optimal load capacity					
		C1 [pF]	C2 [pF]	Rf [Ohm]	Rd [Ohm]	Supply voltage Range [V]	Operating Temperature Range [°C]
4M	CSTCR4M00G55B-R0	39(internal)		---	--	4.5 to 5.5	-40 to +125
4.096M	CSTCR4M09G55B-R0						

Circuit diagram

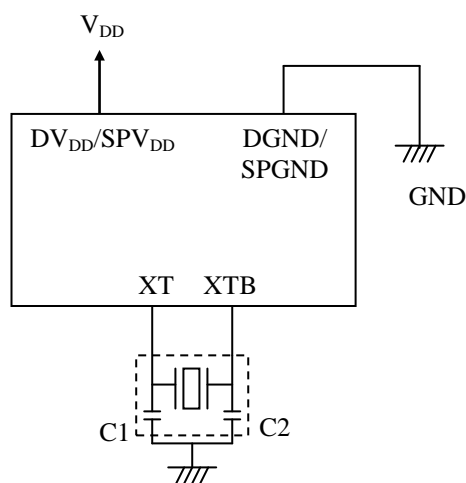

LIMITATION ON THE OPERATION TIME (PLAY-BACK TIME)

ML22Q553's operating temperature is 105°C. But the average ambient temperature at 1W play-back (8ohm drive) during 10 years in the reliability design is Ta=70°C. (max (the package heat resistance θ_{ja} =24.6[°C/W])

When ML22Q553 operates 1W play-back(8ohm drive) consecutively, the product life changes by the package temperature rise by the consumption. This limitation does not matter in the state that a speaker amplifier does not play.

The factor to decide the operation time (play-back time) is the average ambient temperature(Ta), play-back Watts(at the speaker drive mode), the soldering area ratio*1, and so on. In addition, the limitation on the operation time changes by the heat designs of the board.

PACKAGE HEAT RESISTANCE VALUE (REFERENCE VALUE)

The following table is the package heat resistance value θ_{ja} (reference value). This value changes the condition of the board (size, layer number, and so on)

The board	θ_{ja}	The condition
JEDEC 4layers*1 (W/L/t=76.2/114.5/1.6(mm))	24.6[°C /W]	No wind (0m/sec) the soldering area ratio*3: 100%
JEDEC 2layers*2 (W/L/t=76.2/114.5/1.6(mm))	31.2[°C /W]	

*1 : The wiring density : 1st layer(Top) 60% / 2nd layer 100% / 3rd layer 100% / 4th layer(Bottom) 60%.

*2 : The wiring density : 1st layer(Top) 60% / 2nd layer(Bottom) 100%.

*3 : The soldering area ratio is the ratio that the heat sink area of ML22Q553 and a land pattern on the board are soldered. 100% mean that the heat sink area of ML22Q553 is completely soldered to the land pattern on the board. About the land pattern on the board, be sure to refer to the next clause (PACKAGE DIMENSIONS).

PACKAGE DIMENSIONS

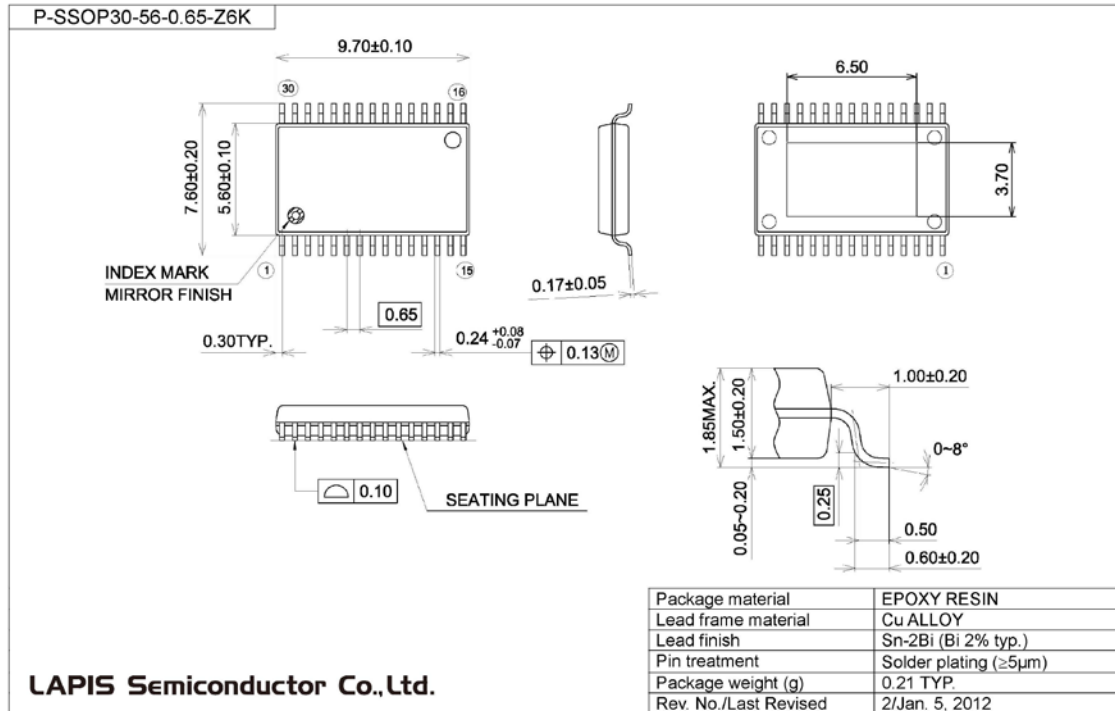

Notes for Mounting the Surface Mount Type Package

The surface mount type packages are very susceptible to heat in reflow mounting and humidity absorbed in storage. Therefore, before you perform reflow mounting, contact a ROHM sales office for the product name, package name, pin number, package code and desired mounting conditions (reflow method, temperature and times).

Notes for heat sink type Package

This LSI adopts a heat sink type package to raise a radiation of heat characteristic. Be sure to design the land pattern corresponding to the heat sink area of the LSI on a board, and solder each other. The heat sink area of the LSI solder open or GND on the board.

REVISION HISTORY

Document No.	Date	Page		Description
		Previous Edition	Current Edition	
FEDL22Q553FULL-01	Jun. 19, 2012	-	-	Formally edition 1.
FEDL22Q553-02	Apr. 25, 2013	11	11	Add tCB3.
		16	16	Change Playback Stop Timing.
FEDL22Q553-03	Dec. 9, 2014	-	31	Add tPUPA3 timing diagram.
		-	32	Add tPDA3 timing diagram.
FEDL22Q553-04	Mar. 18, 2015	11	11	Modify tCB2.(2ms(max) -> 3ms(max))

Notes

- 1)The information contained herein is subject to change without notice.
- 2)Although LAPIS Semiconductor is continuously working to improve product reliability and quality, semiconductors can break down and malfunction due to various factors. Therefore, in order to prevent personal injury or fire arising from failure, please take safety measures such as complying with the derating characteristics, implementing redundant and fire prevention designs, and utilizing backups and fail-safe procedures. LAPIS Semiconductor shall have no responsibility for any damages arising out of the use of our Products beyond the rating specified by LAPIS Semiconductor.
- 3)Examples of application circuits, circuit constants and any other information contained herein are provided only to illustrate the standard usage and operations of the Products. The peripheral conditions must be taken into account when designing circuits for mass production.
- 4)The technical information specified herein is intended only to show the typical functions of the Products and examples of application circuits for the Products. No license, expressly or implied, is granted hereby under any intellectual property rights or other rights of LAPIS Semiconductor or any third party with respect to the information contained in this document; therefore LAPIS Semiconductor shall have no responsibility whatsoever for any dispute, concerning such rights owned by third parties, arising out of the use of such technical information.
- 5)The Products are intended for use in general electronic equipment (i.e. AV/OA devices, communication, consumer systems, gaming/entertainment sets) as well as the applications indicated in this document.
- 6)The Products specified in this document are not designed to be radiation tolerant.
- 7)For use of our Products in applications requiring a high degree of reliability (as exemplified below), please contact and consult with a LAPIS Semiconductor representative: transportation equipment (i.e. cars, ships, trains), primary communication equipment, traffic lights, fire/crime prevention, safety equipment, medical systems, servers, solar cells, and power transmission systems.
- 8)Do not use our Products in applications requiring extremely high reliability, such as aerospace equipment, nuclear power control systems, and submarine repeaters.
- 9)LAPIS Semiconductor shall have no responsibility for any damages or injury arising from non-compliance with the recommended usage conditions and specifications contained herein.
- 10)LAPIS Semiconductor has used reasonable care to ensure the accuracy of the information contained in this document. However, LAPIS Semiconductor does not warrant that such information is error-free and LAPIS Semiconductor shall have no responsibility for any damages arising from any inaccuracy or misprint of such information.
- 11)Please use the Products in accordance with any applicable environmental laws and regulations, such as the RoHS Directive. For more details, including RoHS compatibility, please contact a ROHM sales office. LAPIS Semiconductor shall have no responsibility for any damages or losses resulting non-compliance with any applicable laws or regulations.
- 12)When providing our Products and technologies contained in this document to other countries, you must abide by the procedures and provisions stipulated in all applicable export laws and regulations, including without limitation the US Export Administration Regulations and the Foreign Exchange and Foreign Trade Act.
- 13)This document, in part or in whole, may not be reprinted or reproduced without prior consent of LAPIS Semiconductor.

Copyright 2010-2015 LAPIS Semiconductor Co., Ltd.

LAPIS Semiconductor Co.,Ltd.

2-4-8 Shinyokohama, Kouhoku-ku,
Yokohama 222-8575, Japan
<http://www.lapis-semi.com/en/>