

DFA6 SERIES SINGLE OUTPUT

DESCRIPTION

The DFA6 Series provides quick power conversion solutions to analog and digital systems. Requires few external components. The converters provide plug-and-play versatility. The series features an input range of 3:1. The output is electrically isolated, thereby allowing the output to be configured for positive or negative output voltage. The DFA6 provides compact system power in less than 2.3 square inches (14.8 cm²).

The DFA6 Series' ultra-wide input and no load input current (7mA) makes it well suited for battery operation in commercial and industrial applications. Full overload protection is provided by pulse-by-pulse current limiting.

FEATURES

- Up to 6 Watts Output Power
- Overcurrent Protection
- Efficiency to 83%
- Low Input to Output Capacitance
- 700V Isolation, Input to Output
- Ultra-Wide Input Range (3:1)

Selection Chart				
Model	Input Range VDC (4)		Output VDC	Output mA
	Min	Max		
DFA6U12S5	9	27	5	1000
DFA6U12S12	9	27	12	500
DFA6U12S15	9	27	15	400
DFA6U48S5	20	60	5	1000
DFA6U48S12	20	60	12	500
DFA6U48S15	20	60	15	400

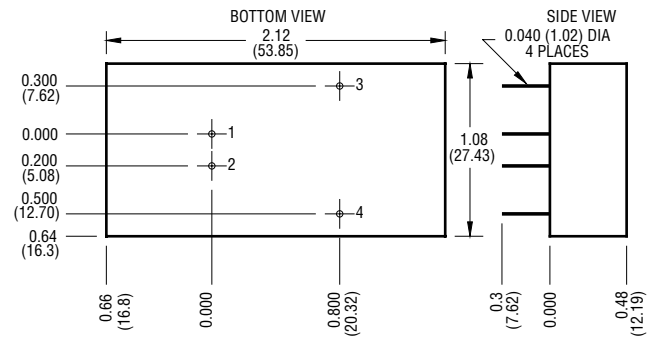

General Specifications (1)				
All Models				Units
Isolation				
Isolation Voltage Input to Output 10µA Leakage	MIN	700	VDC	
Input to Output Capacitance	TYP	400	pF	
Environmental				
Case Operating Range, Tc No Derating	MIN MAX	-40 85	°C	
Storage Range	MIN MAX	-55 105	°C	
Thermal Impedance (2)	TYP	20	°C/Watt	
General				
MTBF (Calculated)	TYP	800,000	HRS	
Unit Weight	TYP	1.0 / 28	oz / gm	
Chassis Mounting Kits	CM2A1			

Mechanical tolerances unless otherwise noted:

X.XX dimensions: ±0.040 inches

X.XXX dimensions: ±0.010 inches

Pin	Function
1	+INPUT
2	-INPUT
3	+OUT
4	-OUT

NOTES

- (1) All parameters measured at Tc=25°C, nominal input voltage and full rated load unless otherwise noted. Refer to the Technical Reference Section for the definition of terms, measurement circuits and other information.
- (2) The case Thermal Impedance is specified as the case temperature rise over ambient per package dissipated

For the Most Up-To-Date Information

www.power-one.com

24 Hours/Day—7 Days/Week



NUCLEAR AND MEDICAL APPLICATIONS Power-One products are not authorized for use as critical components in life support systems, equipment used in hazardous environments, or nuclear control systems without the express written consent of the President of Power-One, Inc.

TECHNICAL REVISIONS The appearance of products, including safety agency certifications pictured on labels, may change depending on the date manufactured. Specifications are subject to change without notice.

DFA6 SERIES – SINGLE OUTPUT

Input Parameters (1)									
Model		DFA6U12S5	DFA6U12S12	DFA6U12S15	DFA6U48S5	DFA6U48S12	DFA6U48S15	Units	
Voltage Range	MIN	9			20			VDC	
	MAX	27			60				
Reflected Ripple (2)	TYP	1.8			0.85			A _{PP} A _{rms}	
	TYP	0.93			0.44				
Input Current	Full Load	TYP	520	600	130	154	160	mA	
	No Load	TYP	6	12	5	6	6		
Efficiency	TYP	80	83	80	82	79	%		
Switching Frequency	TYP	125						kHz	
Maximum Input Overvoltage	MAX							VDC	
100ms Maximum									34
12V Models 48V Models									72
Turn-on Time, 1% Output Error	TYP	6						ms	

Output Parameters (1)								
Model		DFA6U12S5	DFA6U48S5	DFA6U12S12	DFA6U48S12	DFA6U12S15	DFA6U48S15	Units
Output Voltage		5		12		15		VDC
Output Voltage Accuracy	MIN	4.95		11.90		14.90		VDC
	TYP	5.00		12.00		15.00		
	MAX	5.05		12.10		15.10		
Rated Load Range	MIN	0.0		0.0		0.0		A
	MAX	1.0		0.5		0.4		
Load Regulation 25% - 100% of Rated Load	TYP	0.1		0.2		0.2		%
	MAX	0.3		0.4		0.4		
Line Regulation Vin = Min to Max VDC	TYP	0.02		0.2		0.2		%
	MAX	0.2		0.8		0.8		
Short Term Stability (3)	TYP	< 0.05						%/24Hrs
Input Ripple Rejection (4)	TYP	> 40						dB
Noise, Peak - Peak (2)	TYP	50						mV _{PP}
RMS Noise	TYP	8						mV _{rms}
Temperature Coefficient	TYP	50						ppm/°C
	MAX	150						
Short Circuit Protection +OUT to -OUT		Continuous, Current Limit Protection						

NOTES

- (1) All parameters measured at Tc=25°C, nominal input voltage and full rated load unless otherwise noted. Refer to the Technical Reference Section for the definition of terms, measurement circuits and other information.
- (2) Noise is measured per Technical Reference Section. Measurement bandwidth is 0-20 MHz for peak-peak measurements, 10 kHz to 1 MHz for RMS measurements. Output noise is measured with a 1µF / 35V Tantalum capacitor, 1 inch from the output pins to simulate standard PCB decoupling capacitance. Reflected Ripple is measured with the appropriate input capacitor, and into a 10 µH source impedance. See application notes for input capacitor requirements.
- (3) Short term stability is specified after a 30 minute warmup at full load, constant line and recording the drift over a 24 hour period.
- (4) The input ripple rejection is specified for DC to 120 Hz ripple with a modulation amplitude of 1% of Vin.

DFA6 SERIES APPLICATION NOTES:

External Capacitance Requirements

No external capacitance is required for operation of the DFA6 Series. To meet the reflected ripple requirements of the converter, an input impedance of less than 0.35 Ohms from DC to 250kHz is required. If a capacitive input source is farther than 1" from the converter, an additional capacitor may be required at the input pins for proper operation. External output capacitance is not required for operation, however it is recommended that 1µF to 10µF of tantalum and 0.001 to 0.1µF ceramic capacitance be selected for reduced system noise. Additional output capacitance may be added for increased filtering, but should not exceed 400µF.

Negative Outputs

A negative output voltage may be obtained by connecting the +OUT to circuit ground and connecting -OUT as the negative output.

DFA6 SERIES – SINGLE OUTPUT

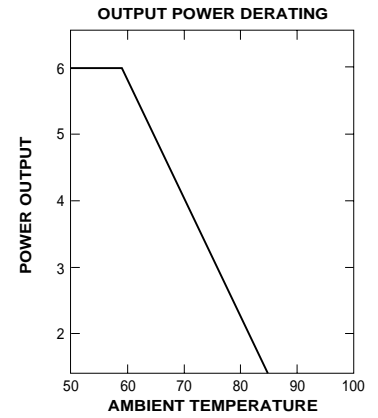
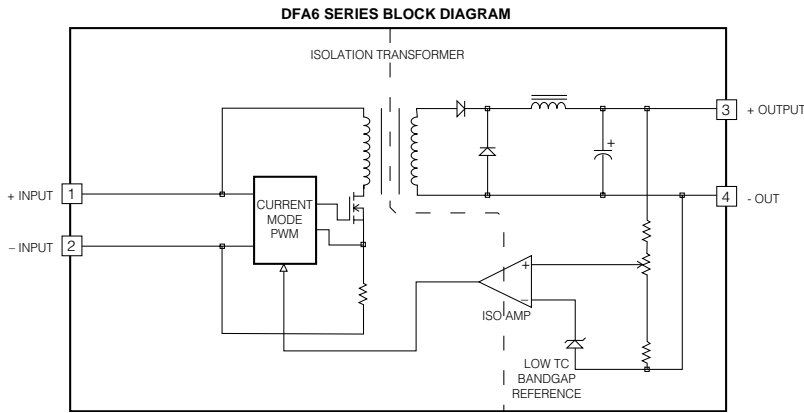

Typical Performance: (Tc=25°C, Vin=Nom VDC, Rated Load)

Data for 12 Volt Input Models

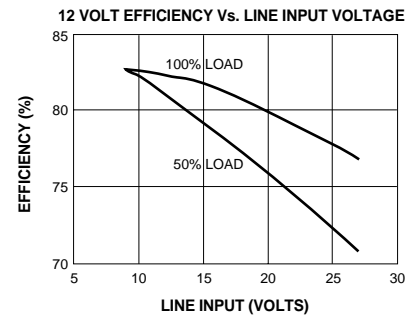
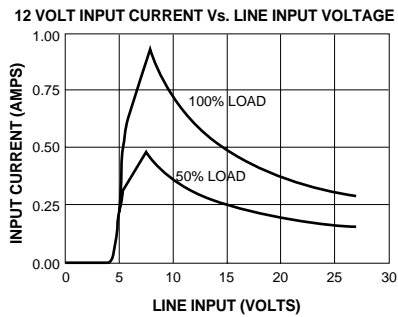
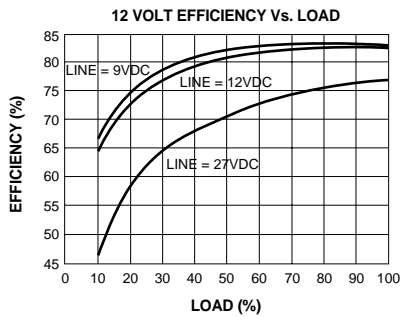

Data for 48 Volt Input Models

