

# ECC100 Series

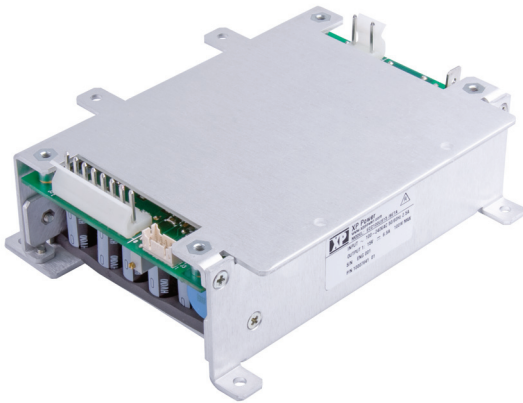

- -40 °C to +75 °C Operation
- 100 W – Baseplate Cooled
- High Efficiency Resonant Topology
- Screw Terminals Available
- 5V Standby Output
- Remote On/Off & Power OK Signal
- 3 Year Warranty

The ECC100 is a conduction cooled single output AC-DC power supply. It is designed for use in harsh environments where wide temperature variation and sealed enclosure installation is common place. Featuring highly efficient resonant mode topology, whilst maintaining its cost effectiveness, the ECC100 also provides remote sense, remote on/off, a combined AC & DC fail signal which coupled with its own standby rail ensures that control and status reporting is easily achievable.

Comprehensive overload, short circuit, over voltage and over temperature are built into the ECC100 as standard. An optional surge filter provides further protection from incoming AC surges to level 4 of EN61000-4-5.

## Models and Ratings

Output Power	Output Voltage V1	Max Output Current V1	Standby Supply V2	Model Number
100 W	12.0 VDC	8.1 A	5.0 V/0.5 A	ECC100US12
100 W	15.0 VDC	6.5 A	5.0 V/0.5 A	ECC100US15
100 W	24.0 VDC	4.1 A	5.0 V/0.5 A	ECC100US24
100 W	28.0 VDC	3.5 A	5.0 V/0.5 A	ECC100US28
100 W	48.0 VDC	2.0 A	5.0 V/0.5 A	ECC100US48

### Notes:

1. For optional surge filter add suffix '-F' to model number, e.g. ECC100US12-F.
2. Add suffix '-S' for screw terminals, consult sales for restrictions and availability.

## Input Characteristics

Characteristic	Minimum	Typical	Maximum	Units	Notes & Conditions
Input Voltage - Operating	85	115/230	264	VAC	Derate output power < 90 VAC. See fig. 1. Power OK signal cannot be used <90 VAC.
Input Frequency	47	50/60	400	Hz	Agency approval 47-63 Hz
Power Factor		>0.5			230 VAC, 100% load EN61000-3-2 class A compliant
Input Current - No Load		0.07/0.09		A	115/230 VAC
Input Current - Full Load		1.5/0.9		A	115/230 VAC
Inrush Current			40	A	230 VAC cold start, 25 °C
Earth Leakage Current		110/190	300	µA	115/230 VAC/50 Hz (Typ.), 264 VAC/60 Hz (Max.)
		0.5/1.2		mA	115/230 VAC/400 Hz
Input Protection	T5.0A/250 V internal fuse in both line and neutral				

## Output Characteristics

Characteristic	Minimum	Typical	Maximum	Units	Notes & Conditions
Output Voltage - V1	12		48	VDC	See Models and Ratings table
Initial Set Accuracy			$\pm 1^{(V1)}$ & $\pm 3^{(V2)}$	%	50% load, 115/230 VAC
Output Voltage Adjustment	$\pm 5$			%	V1 only via potentiometer. See mech. details (P13).
Minimum Load	0			A	
Start Up Delay		1.0		s	230 VAC full load (see fig.2)*
Hold Up Time	16	20		ms	115 VAC full load (see fig.3 & 4)
Drift			$\pm 0.2$	%	After 20 min warm up
Line Regulation			$\pm 0.5$	%	90-264 VAC
Load Regulation			$\pm 1^{(V1)}$ , $\pm 5^{(V2)}$	%	0-100% load
Transient Response - V1			4	%	Recovery within 1% in less than 500 µs for a 50-75% and 75-50% load step
Over/Undershoot - V1		5		%	See fig.5
Ripple & Noise			$1^{(V1)}$ & $2^{(V2)}$	% pk-pk	20 MHz bandwidth (see fig.6 & 7)
Overvoltage Protection	115		140	%	Vnom DC. Output 1 only, recycle input to reset
Overload Protection	110		150	% I nom	Output 1 only, auto reset (see fig.8)
Short Circuit Protection					Continuous, trip & restart (hiccup mode) all outputs
Temperature Coefficient			0.05	%/°C	
Overtemperature Protection		110		°C	Main transformer sensor shutdown

\* At low temperature and low line voltage, start up time will increase.

## Input Voltage Derating

Figure. 1

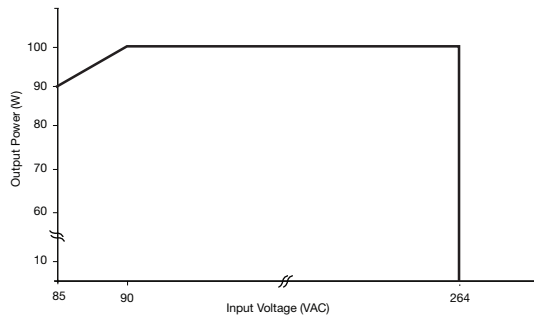

## Start Up Delay From AC Turn On

Figure 2  
V1 & V2 start up example  
from AC turn on

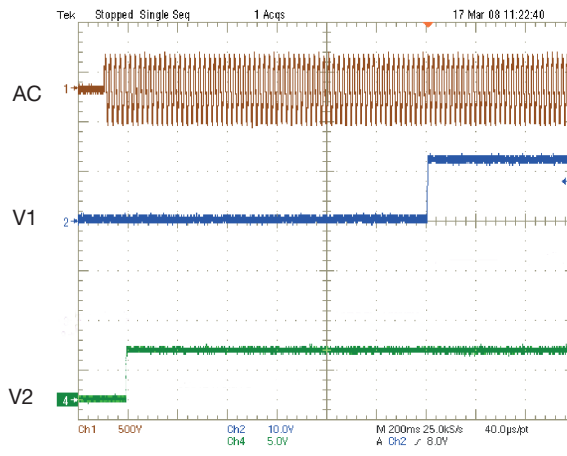

## Hold Up Time From Loss of AC

Figure 3  
V1 hold up example at 100 W load  
with 90 VAC input (16.7 ms)

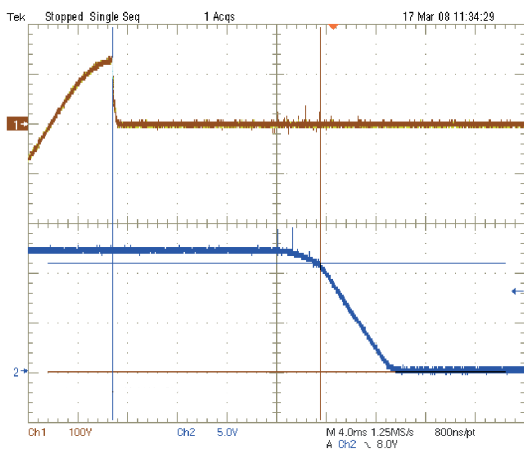
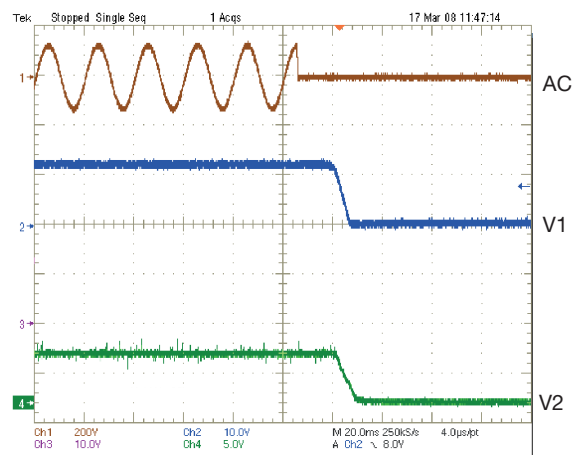
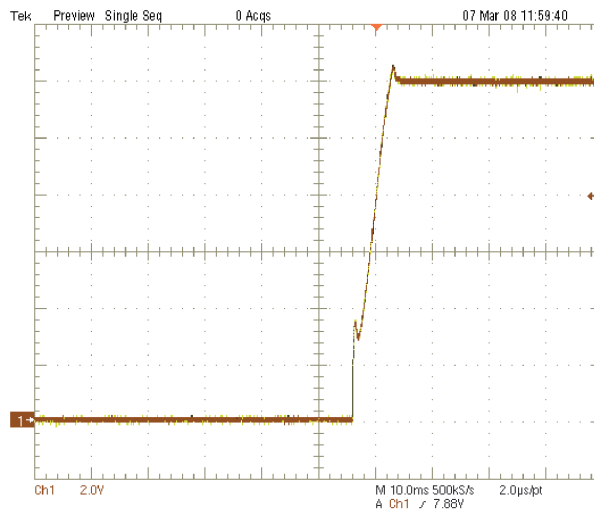

Figure 4  
V1 & V2 hold up example at  
100 W load 90 VAC input



## Output Overshoot

Figure 5  
Typical Output Overshoot  
(ECC100US12 shown)



## Output Ripple & Noise

Figure 6  
V1 ECC100 (full load)  
27 mV pk-pk ripple. 20 MHz BW

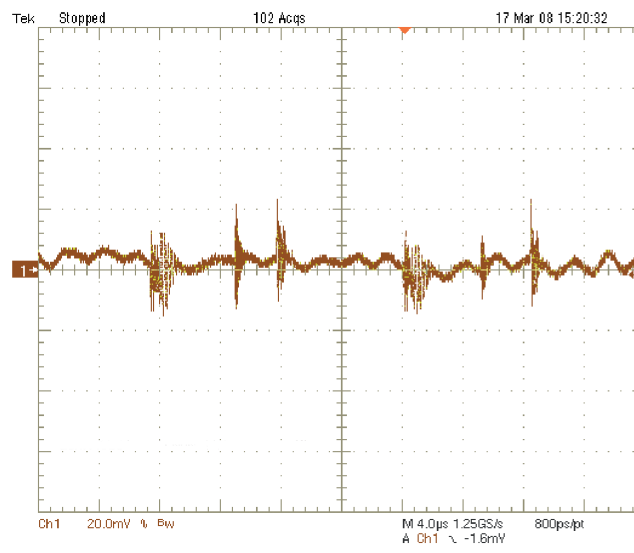

## Output Ripple & Noise cont.

Figure 7  
V1 ECC100US12 (full load)  
39 mV pk-pk ripple. 20 MHz BW

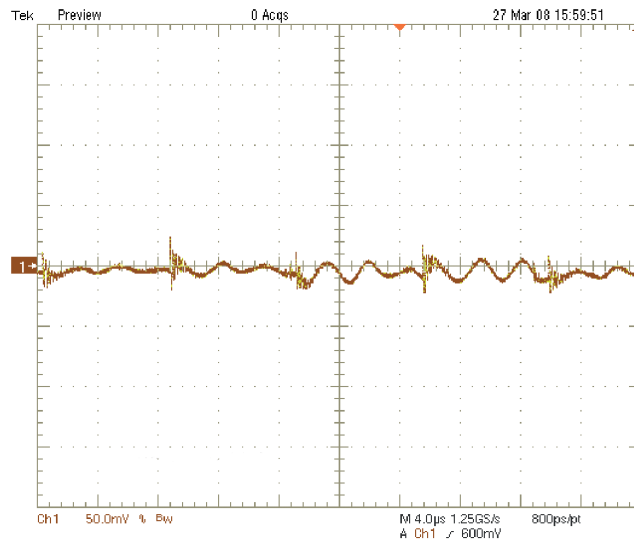

## Output Overload Characteristic

Figure 8  
Typical V1 Overload  
Characteristic  
(ECC100US12 shown)

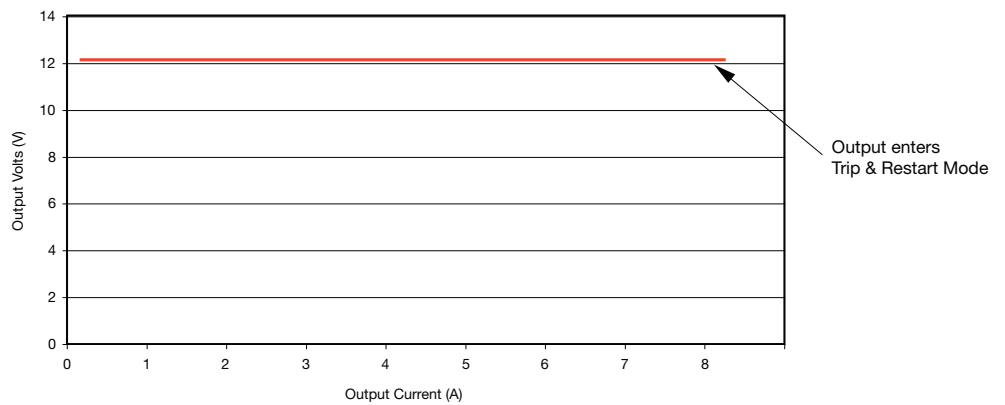

## General Specifications

Characteristic	Minimum	Typical	Maximum	Units	Notes & Conditions
Efficiency		88		%	Full load (see fig.9 & 10)
Isolation: Input to Output Input to Ground Output to Ground	4000			VAC	
	1500			VAC	
	500			VAC	
Switching Frequency		70		kHz	
Power Density			3.9	W/in <sup>3</sup>	
Mean Time Between Failure		236		kHrs	MIL-HDBK-217F, Notice 2 +25 °C GB
Weight			0.7 (320)	lb (g)	

## Efficiency Versus Load

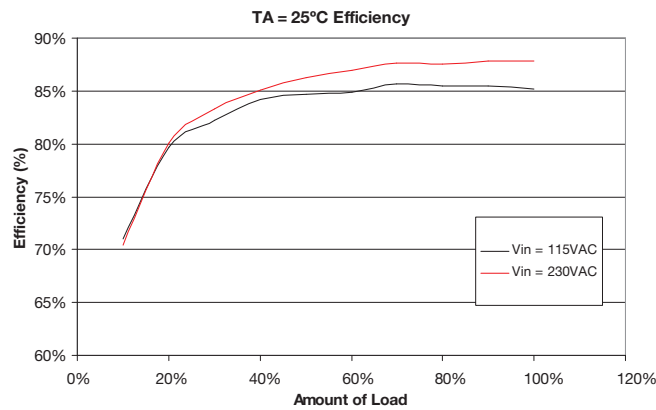

Figure 9  
ECC100US12 at 115 & 230 VAC

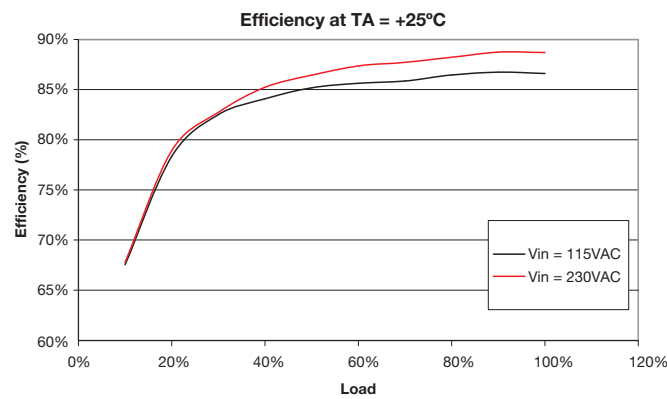

Figure 10  
ECC100US24 at 115 & 230 VAC

Characteristic	Notes & Conditions
<b>Signals &amp; Control</b>	
Remote Sense	Compensates for 0.5 V total voltage drop
Power OK (combined AC OK & DC OK)	Open collector referenced to logic ground & output 0V, transistor normally off when AC is good (see fig.11 - 15) AC OK: Provides ≥ 3 ms warning of loss of output from AC failure
Remote On/Off (Inhibit/Enable)	Uncommitted isolated optocoupler diode, powered diode inhibits the supply (see fig.16-21)
Standby Supply V3	5 V/0.5 A supply, always present when AC supplied, referenced to logic ground and output 0V

# Signals

## Power OK

Figure 11

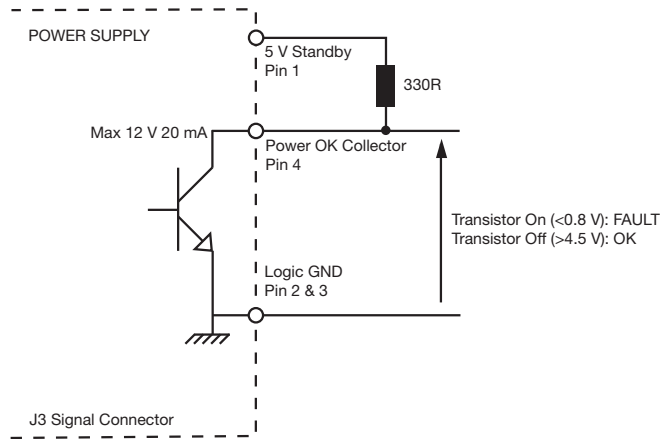

## Power OK - Timing Diagram

Figure 12

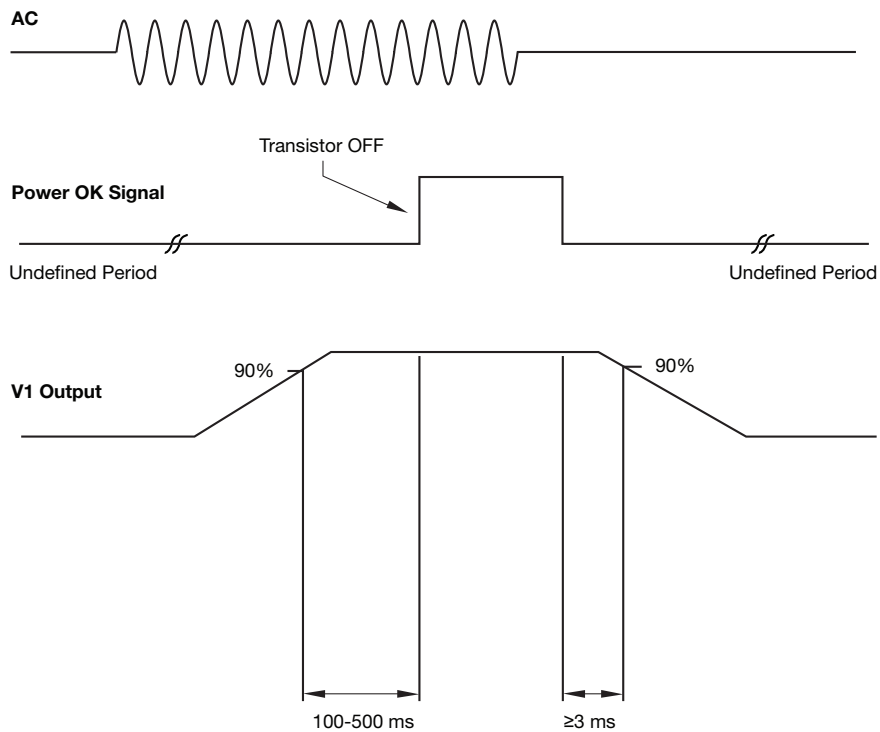

## Signals (cont'd)

### Power OK

Figure 13  
Power OK signal example  
at AC switch on

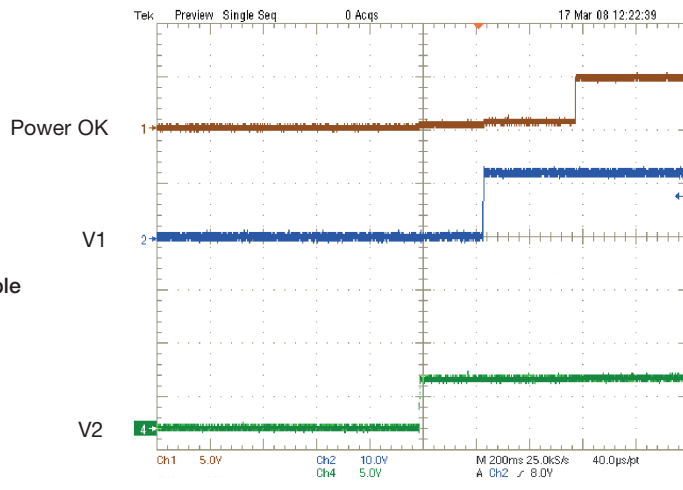

Figure 14  
Power OK signal example  
at AC switch off

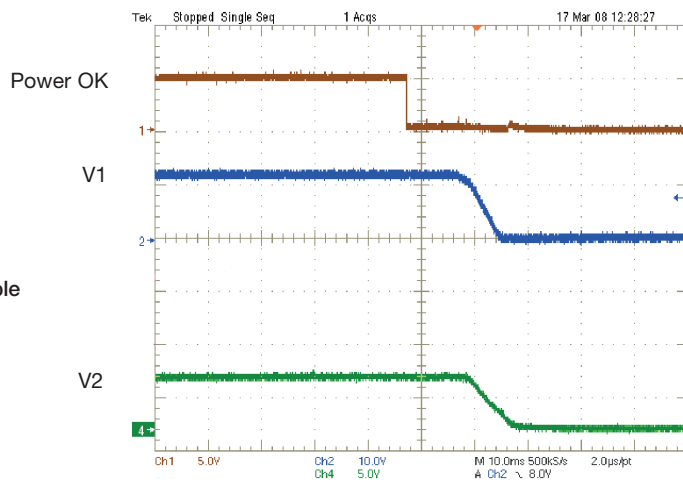
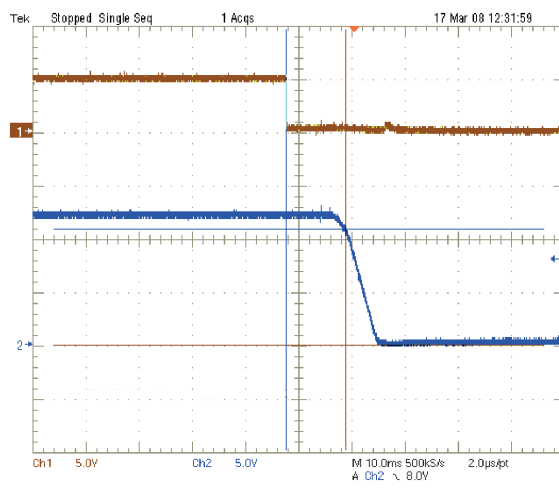

Figure 15  
V1 warning time example at  
Power OK signal 90 VAC  
100 W load (11.2 ms)





## Signals (cont'd)

### Remote On/Off (Inhibit/Enable)

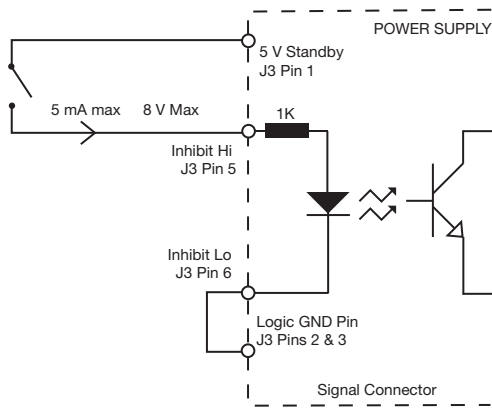

Figure 16  
Inhibit (Hi)

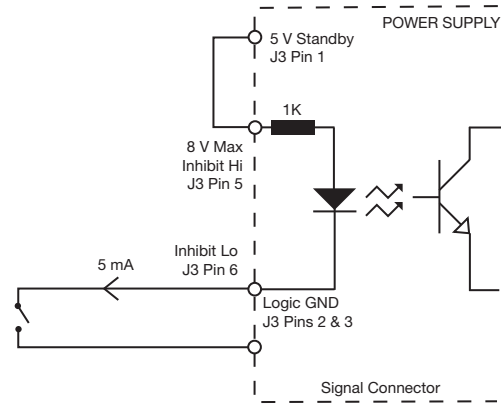

Figure 17  
Inhibit (Lo)

Figure 18  
Example of outputs switching off when Inhibit (Lo) configuration used & switch closed

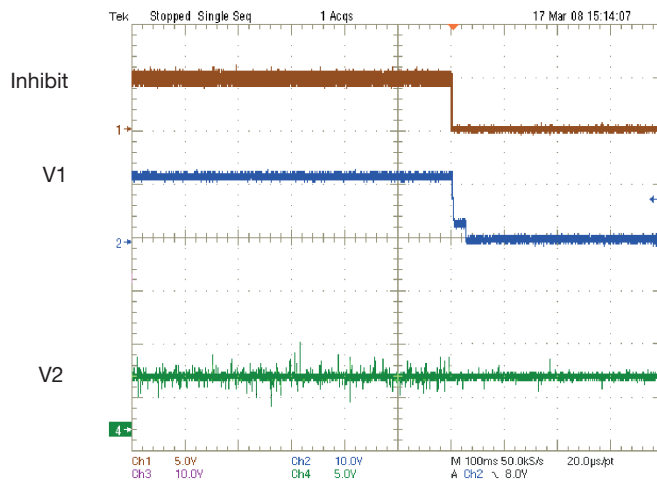
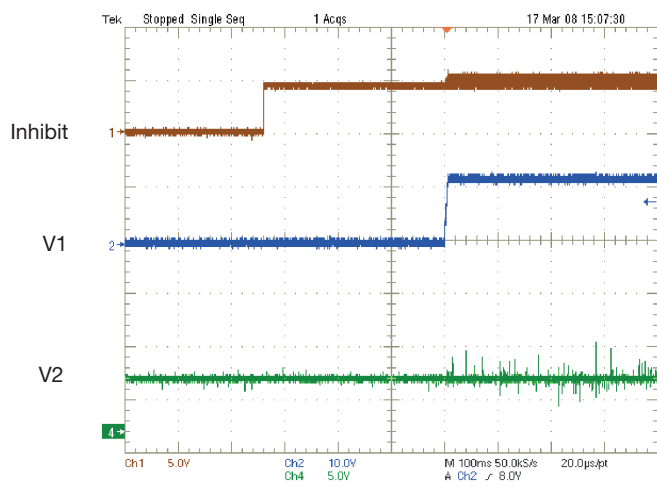

Figure 19  
Example of outputs switching on when Inhibit (Lo) configuration used & switch open



Signals (cont'd)

Remote On/Off (Inhibit/Enable)

Figure 20  
Enable (Hi)

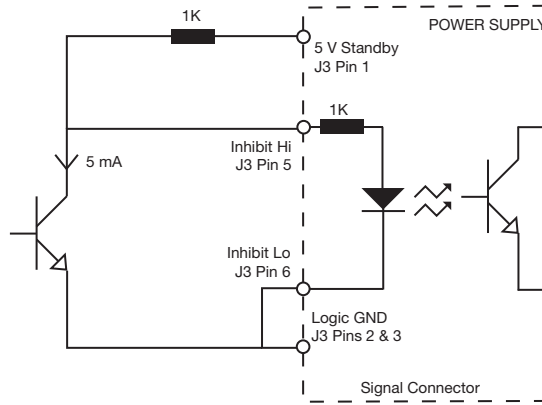
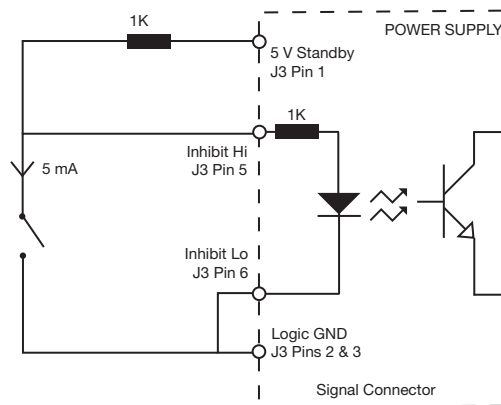

Figure 21  
Enable (Lo)



## Environmental

Characteristic	Minimum	Typical	Maximum	Units	Notes & Conditions
Operating Temperature	-40		+75	°C	Baseplate must not exceed 85°C. See thermal considerations.
Warm Up Time		20		Minutes	
Storage Temperature	-40		+85	°C	
Cooling					Baseplate cooled
Humidity	5		95	%RH	Non-condensing
Operating Altitude			3000	m	
Shock					3 x 30 g/11 ms shocks in both +ve & -ve directions along the 3 orthogonal axis, total 18 shocks.
Vibration					Triple axis 5-500 Hz at 2 g x 10 sweeps

## Electromagnetic Compatibility - Immunity

Phenomenon	Standard	Test Level	Criteria	Notes & Conditions
Low Voltage PSU EMC	EN61204-3	High severity level	as below	
Harmonic Current	EN61000-3-2	Class A		
Radiated	EN61000-4-3	3	A	
EFT	EN61000-4-4	3	A	
Surges	EN61000-4-5	Installation class 3	A	
		Installation class 4	A	With option -F
Conducted	EN61000-4-6	3	A	
Dips and Interruptions	EN61000-4-11	Dip: 30% 10 ms	A	
		Dip: 60% 100 ms	B	
		Dip: 100% 5000 ms	B	

## Electromagnetic Compatibility - Emissions

Phenomenon	Standard	Test Level	Criteria	Notes & Conditions
Conducted	EN55022	Class B		
Radiated	EN55022	Class A		
Voltage Fluctuations	EN61000-3-3			

## Safety Agency Approvals

Safety Agency	Safety Standard	Category
CB Report	UL File #E139109-A42-CB-1, IEC60950-1 (2005) Second Edition	Information Technology
UL	UL File #E139109-A42-UL, UL60950-1, 2nd Edition, 2007-03-27, CSA C22.2 No 60950-1-07 2nd Edition 2007-03	Information Technology
TUV	TUV Certificate B 09 12 57396 067, EN60950-1/A11:2009	Information Technology
CE	LVD	

Equipment Protection Class	Safety Standard	Notes & Conditions
Class I	IEC60950-1:2005 Ed 2	See safety agency conditions of acceptability for details

## Mechanical Details - ECC100USxx

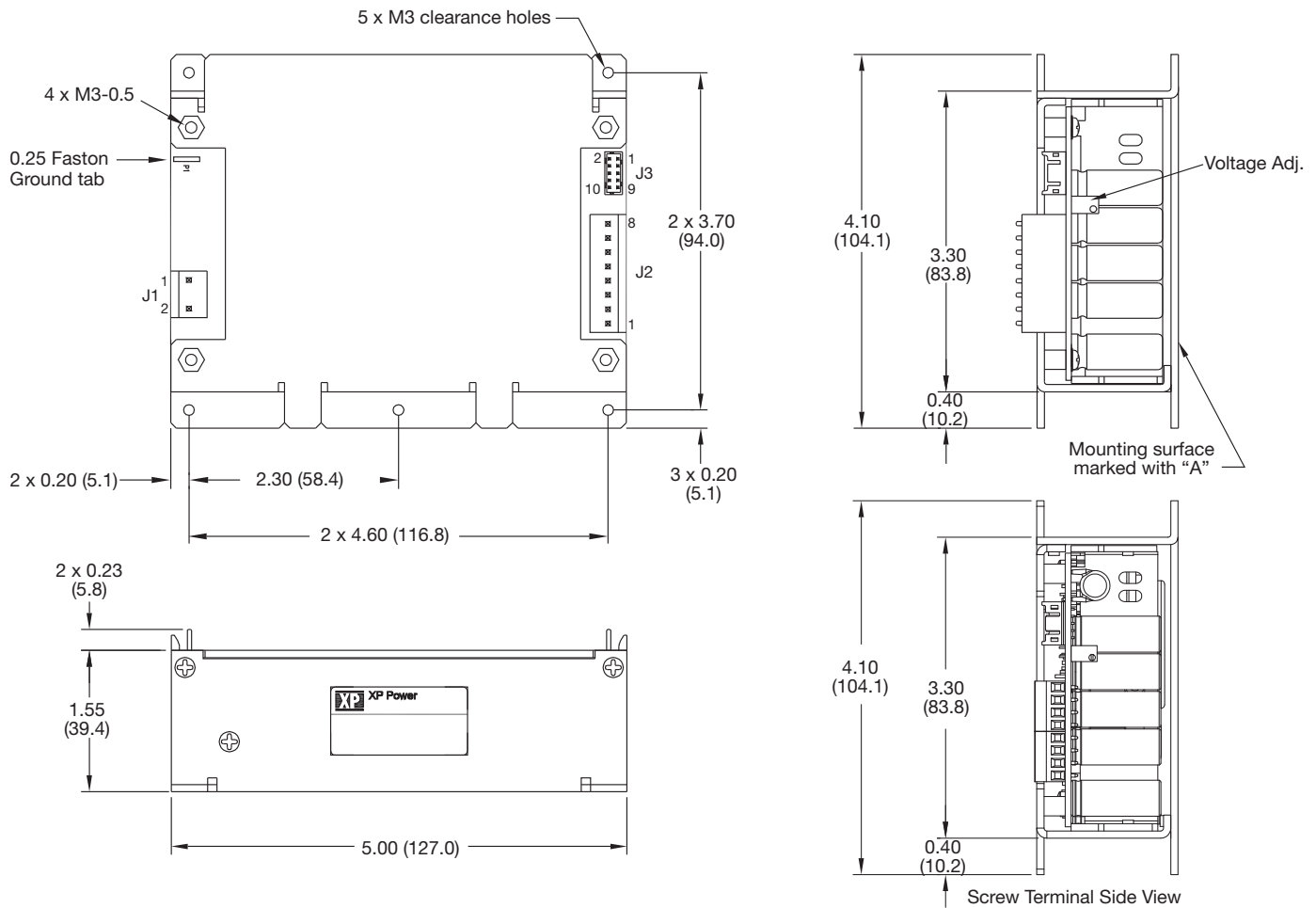

Output Connector J2 Molex PN 09-65-2088	
Pin	Single Output
1	+V1
2	+V1
3	+V1
4	+V1
5	RTN
6	RTN
7	RTN
8	RTN

J2 mates with Molex housing PN 09-50-1081 and both with Molex series 5194 crimp terminals.

Input Connector J1 Molex PN 09-65-2038	
Pin	
1	Line
2	Neutral

J1 mates with Molex housing PN 09-50-1031.

Signal Connector J3 Molex PN B10B-PHDSS	
Pin	
1	+5 V Standby
2	Logic GND
3	Logic GND
4	Power OK
5	Inhibit Hi
6	Inhibit Lo
7	+Sense
8	-Sense
9	+Vout
10	-Vout

J3 mates with JST housing PN PHDR-10VS and with JST SPHD-001T-P0.5 crimp terminals.

### Notes

1. All dimensions in inches (mm).
2. Tolerance .xx = ±0.02 (0.50); .xxx = ±0.01 (0.25)

3. Weight 1.2 lbs (550g)

## Mechanical Details - ECC100USxx-F

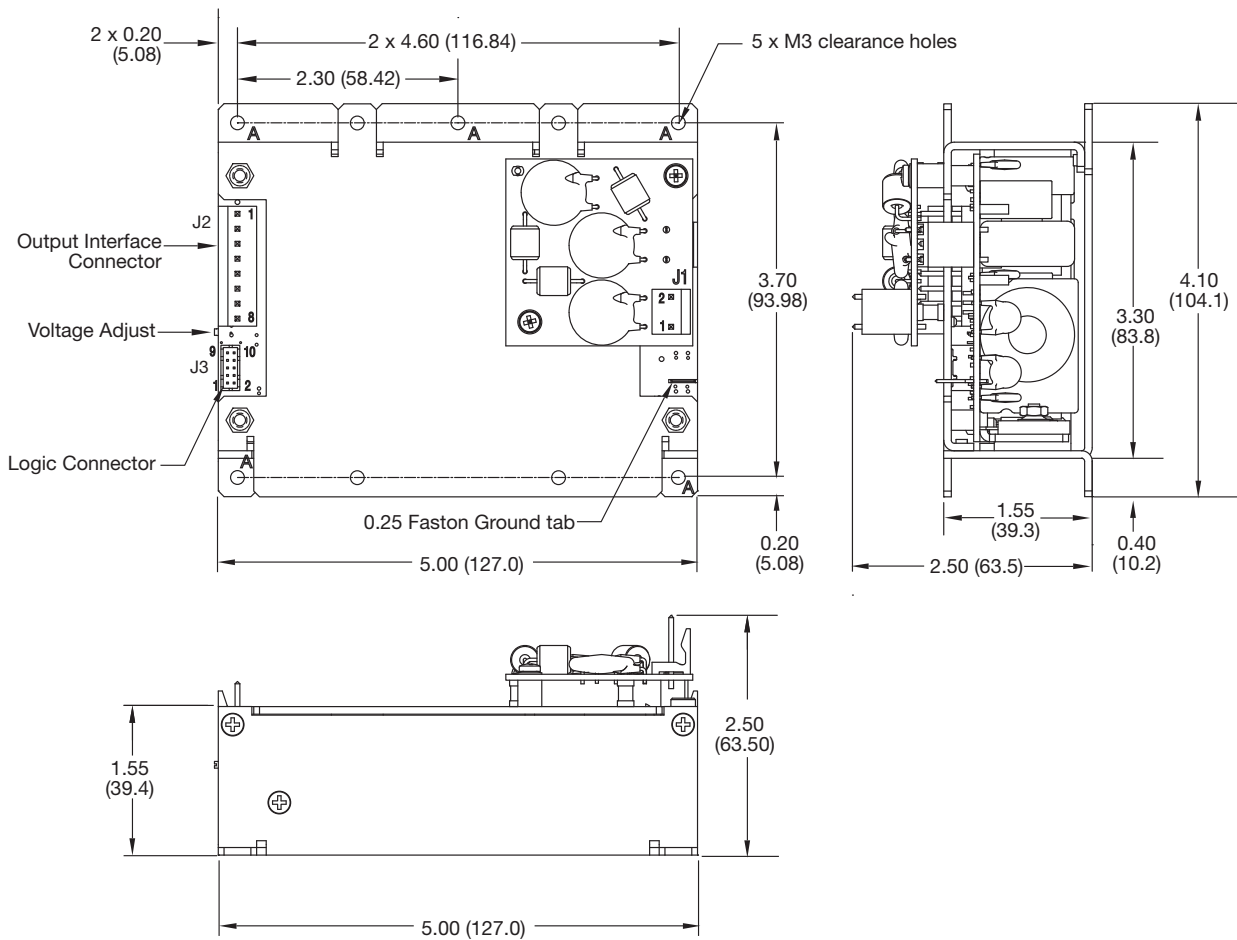

Output Connector J2 Molex PN 09-65-2088	
Pin	Single Output
1	+V1
2	+V1
3	+V1
4	+V1
5	RTN
6	RTN
7	RTN
8	RTN

J2 mates with Molex housing PN 09-50-1081 and both with Molex series 5194 crimp terminals.

Input Connector J1 Molex PN 09-65-2038	
Pin	Line
1	Line
2	Neutral

J1 mates with Molex housing PN 09-50-1031.

Signal Connector J3 Molex PN B10B-PHDSS	
Pin	Signal
1	+5 V Standby
2	Logic GND
3	Logic GND
4	Power OK
5	Inhibit Hi
6	Inhibit Lo
7	+Sense
8	-Sense
9	+Vout
10	-Vout

J3 mates with JST housing PN PHDR-10VS and with JST SPHD-001T-P0.5 crimp terminals.

### Notes

1. All dimensions in inches (mm).
2. Tolerance .xx = ±0.02 (0.50); .xxx = ±0.01 (0.25)

3. Weight 1.2 lbs (550g)

## Thermal Considerations - Baseplate Cooling

The use of power supplies in harsh or remote environments brings with it many fundamental design issues that must be fully understood if long-term reliability is to be attained.

Under these conditions, it is generally accepted that electronic systems have to be sealed against the elements. This makes the removal of unwanted heat particularly difficult. The use of forced-air cooling is undesirable as it increases system size, adds the maintenance issues of cleaning or replacing filters, and the fan being prone to wear out, particularly in tough environments.

The extremes of ambient temperature encountered in remote sites can range from  $-40\text{ }^{\circ}\text{C}$  to over  $+40\text{ }^{\circ}\text{C}$ . It is common for the temperature within the enclosure to rise some 15 to  $20\text{ }^{\circ}\text{C}$  above the external temperature. The positioning of the power supply within the enclosure can help minimize the ambient temperature in which it operates and this can have a dramatic effect on system reliability.

System enclosures are typically sealed to IP65, IP66 or NEMA 4 standards to prevent ingress of dust or water. Removal of heat from other electronic equipment and power supplies in a situation with negligible airflow is the challenge. From the power system perspective, the most effective solution is to remove the heat using a heatsink that is external to the enclosure. However, most standard power supplies cannot provide an adequate thermal path between the heat-dissipating components within the unit and the external environment.

Fundamentally, the successful design of a power supply for use within sealed enclosures relies on creating a path with low thermal resistance through which conducted heat can be passed from heat-generating components to the outside world.

The components that generate the most heat in a power supply are distributed throughout the design, from input to output. They include the power FET used in an active PFC circuit, the PFC inductor, power transformers, rectifiers, and power switches. Heat can be removed from these components by thermally connecting them to the base-plate that in turn can be affixed to a heatsink. As mentioned earlier, the heatsink is then located outside of the enclosure.

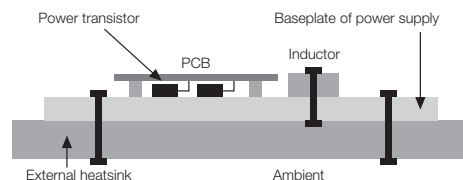

**Basic construction of baseplate cooled PSU with all of the major heat-generating components thermally connected to the baseplate**

### Dissipating the Heat: Heatsink Calculations

Three basic mechanisms contribute to heat dissipation: conduction, radiation and convection. All mechanisms are active to some degree but once heat is transferred from the baseplate to the heatsink by conduction, free convection is the dominant one.

Effective conduction between the baseplate and heatsink demands flat surfaces in order to achieve low thermal resistance. Heat transfer can be maximized by the use of a thermal compound that fills any irregularities on the surfaces. System designers should aim to keep thermal resistance between baseplate and heatsink to below  $0.1\text{ }^{\circ}\text{C}/\text{W}$ . This is the performance offered by most commonly used thermal compounds when applied in accordance with manufacturers' instructions.

Radiation accounts for less than 10% of heat dissipation and precise calculations are complex. In any case, it is good practice to consider this 10% to be a safety margin.

The following example shows how to calculate the heatsink required for an ECC100US12 with 230 VAC input and an output load of 90 W operating in a 40 °C outside ambient temperature.

1. Calculate the power dissipated as waste heat from the power supply. The efficiency (see fig. 9 & 10) and worst case load figures are used to determine this using the formula:

$$\text{Waste heat} = \left\{ \frac{1 - \text{Eff}\%}{\text{Eff}\%} \right\} \times P_{\text{out}} = \left\{ \frac{1 - 0.87}{0.87} \right\} \times 90 \text{ W} = 13.5 \text{ W}$$

2. Estimate the impedance of the thermal interface between the power supply baseplate and the heatsink. This is typically 0.1°C/W when using a thermal compound.

3. Calculate the maximum allowable temperature rise on the baseplate. The allowable temperature rise is simply:

$$T_B - T_A \text{ where } T_A \text{ is the maximum ambient temperature outside of the cabinet}$$

$$\text{and } T_B \text{ is the maximum allowable baseplate temperature.}$$

4. The required heatsink is defined by its thermal impedance using the formula:

$$\theta H = \frac{T_B - T_A}{\text{Waste Power}} \times 0.1 = \frac{85 \text{ °C} - 40 \text{ °C}}{13.5 \text{ W}} \times 0.1 = 3.23 \text{ °C/W}$$

5. The final choice is then based on the best physical design of heatsink for the application that can deliver the required thermal impedance. The system's construction will determine the maximum available area for contact with the baseplate of the power supply and the available space outside of the enclosure will then determine the size, number and arrangement of cooling fins on the heatsink to meet the dissipation requirement.