

9-CH Level Shifters

Features

- **Input Supply Range: 2.6V~5.5V**
- **Protection Function**
 - ◆ Input Under Voltage Lockout (UVLO)
 - ◆ Thermal Overload Protection (150°C)
- **9-Channel Level Shifter**
 - ◆ +40V Highest Voltage Level
 - ◆ -30V Lowest Voltage Level
 - ◆ Maximum 700ns Rising/Falling Time
 - ◆ 500mA Peak Current
 - ◆ 20mA Continuous Current
 - ◆ Gate Shading Function.
- **32-pin, QFN (5mmx5mm) Package**
- **RoHS Compliant**

Applications

- LCD Monitor Panel
- LCD TV panel

General Description

The G2581 is a 9-channel level shifter suitable for TFT-LCD row drivers. This device will level shift a digital input signal to an output voltage nearly equal to its output supply voltage.

The G2581 has 3 supplies: VIN, VGH and VGL1. VIN is low voltage supply with a voltage range from 2.6V to 5.5V. VGH is positive high voltage supply with a voltage range from 7V to 40V. VGL1 is negative high voltage supply with a voltage range from 0V to -30V. CKO_1~CKO_6 are level shifter outputs with gate shading function. STO and LCO_1~LCO_2 are level shifter outputs without gate shading function.

The G2581 features extensive protection functions that include UVLO, OTP. This device operates over the temperature range from -40°C to +85°C.

The G2581 is available in a 5mmx5mm, 32-lead QFN package.

Ordering Information

ORDER NUMBER	MARKING	TEMP. RANGE	PACKAGE (Green)
G2581QA1U	2581	-40°C~ +85°C	QFN5X5-32

Note: QA: QFN5X5-32
 1: Bonding Code
 U: Tape & Reel

Pin Configurations

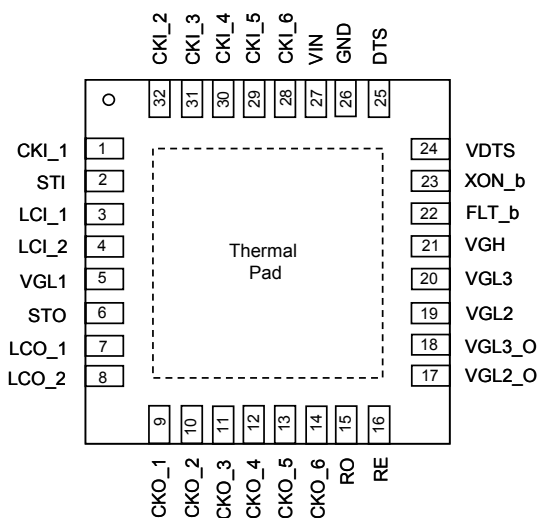

G2581 QFN5X5-32

Note: Recommend connecting the Thermal Pad to the Ground for excellent power dissipation.

Typical Application Circuit

