

CMPA1D1E030D

30 W, 13.75 - 14.5 GHz, 40 V, GaN MMIC, Power Amplifier

Cree's CMPA1D1E030D is a gallium nitride (GaN) High Electron Mobility Transistor (HEMT) based monolithic microwave integrated circuit (MMIC) on a silicon carbide substrate, using a 0.25 μm gate length fabrication process. GaN-on-SiC has superior properties compared to silicon, gallium arsenide or GaN-on-Si, including higher breakdown voltage, higher saturated electron drift velocity and higher thermal conductivity. GaN HEMTs also offer greater power density and wider bandwidths compared to Si, GaAs, and GaN-on-Si transistors.

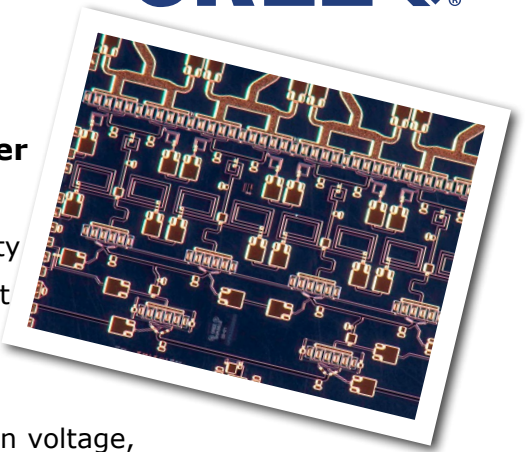

Typical Performance Over 13.75-14.5 GHz ($T_c = 25^\circ\text{C}$)

Parameter	13.75 GHz	14.0 GHz	14.5 GHz	Units
Small Signal Gain	27	26	25	dB
P_{SAT} @ $P_{\text{IN}} = 26$ dBm	33	34	30	W
P_{3dB} Backoff @ $P_{\text{IN}} = 20$ dBm	20	20	16	W
PAE @ $P_{\text{IN}} = 26$ dBm	24	23	22	%
PAE @ $P_{\text{IN}} = 20$ dBm	22	21	20	%

Note: All data in this table is based on fixtured, CW performance.

Features

- 27 dB Small Signal Gain
- 30 W Typical P_{SAT}
- Operation up to 40 V
- High Breakdown Voltage
- High Temperature Operation

Applications

- Satellite Communications Uplink

Absolute Maximum Ratings (not simultaneous) at 25 °C

Parameter	Symbol	Rating	Units	Conditions
Drain-source Voltage	V_{DSS}	84	V_{DC}	25 °C
Gate-source Voltage	V_{GS}	-10, +2	V_{DC}	25 °C
Storage Temperature	T_{STG}	-55, +150	°C	
Operating Junction Temperature	T_J	225	°C	
Maximum Forward Gate Current	I_{GMAX}	10	mA	25 °C
Maximum Drain Current ¹	I_{DMAX}	0.6	A	Stage 1, 25 °C
Maximum Drain Current ¹	I_{DMAX}	0.96	A	Stage 2, 25 °C
Maximum Drain Current ¹	I_{DMAX}	2.2	A	Stage 3, 25 °C
Thermal Resistance, Junction to Case ²	$R_{\theta JC}$	1.5	°C/W	85 °C, $P_{DISS} = 94W$
Mounting Temperature (30 seconds)	T_S	320	°C	30 seconds

Note¹ Current limit for long term, reliable operation. Total current when biased from top and bottom drain pads.

Note² Eutectic die attach using 80/20 AuSn mounted to a 20 mil thick CuMoCu carrier.

Electrical Characteristics (Frequency = 13.75 GHz to 14.5 GHz unless otherwise stated; $T_C = 25 °C$)

Characteristics	Symbol	Min.	Typ.	Max.	Units	Conditions
DC Characteristics						
Gate Threshold	V_{TH}	-3.8	-2.8	-2.3	V	$V_{DS} = 10 V, I_D = 18.2 mA$
Drain-Source Breakdown Voltage	V_{BD}	84	100	-	V	$V_{GS} = -8 V, I_D = 18.2 mA$
RF Characteristics²						
Small Signal Gain	S21	-	27	-	dB	$V_{DD} = 40 V, I_{DQ} = 300 mA$
Input Return Loss	S11	-	-16	-	dB	$V_{DD} = 40 V, I_{DQ} = 300 mA$
Output Return Loss	S22	-	-9	-	dB	$V_{DD} = 40 V, I_{DQ} = 300 mA$
Power Output	P_{OUT1}	-	50	-	W	$V_{DD} = 40 V, I_{DQ} = 300 mA, CW, P_{IN} = 24 dBm$
Power Output	P_{OUT2}	-	24	-	W	$V_{DD} = 40 V, I_{DQ} = 300 mA, P_{IN} = 18 dBm$
Power Added Efficiency	PAE_1	-	30	-	%	$V_{DD} = 40 V, I_{DQ} = 300 mA, CW, P_{IN} = 24 dBm$
Power Added Efficiency	PAE_2	-	25	-	%	$V_{DD} = 40 V, I_{DQ} = 300 mA, P_{IN} = 18 dBm$
Power Gain	G_p	-	22	-	dB	$V_{DD} = 40 V, I_{DQ} = 300 mA$
Output Mismatch Stress	VSWR	-	5 : 1	-	Ψ	No damage at all phase angles, $V_{DD} = 40 V, I_{DQ} = 300 mA, P_{OUT} = 25W CW$

Notes:

¹ Scaled from PCM data.

² All data pulse tested on-wafer with Pulse Width = 10 μs , Duty Cycle = 0.1%.

Block Diagram Showing Additional Capacitors for Operation Over 13.75 to 14.5 GHz

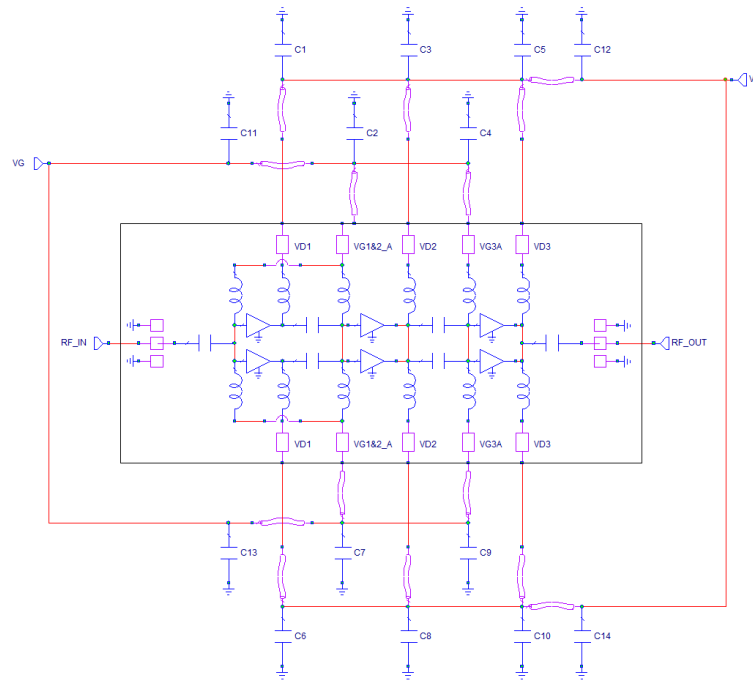

Designator	Description	Quantity
C1,C2,C3,C4,C5,C6,C7,C8,C9,C10	CAP, 51pF, +/-10%, SINGLE LAYER, 0.030", Er 3300, 100V, Ni/Au TERMINATION	10
C11,C12,C13,C14	CAP, 680pF, +/-10%, SINGLE LAYER, 0.070", Er 3300, 100V, Ni/Au TERMINATION	4

Notes:

¹ The input, output and decoupling capacitors should be attached as close as possible to the die- typical distance is 5 to 10 mils with a maximum of 15 mils.

² The MMIC die and capacitors should be connected with 2 mil gold bond wires.

Die Dimensions (units in microns)

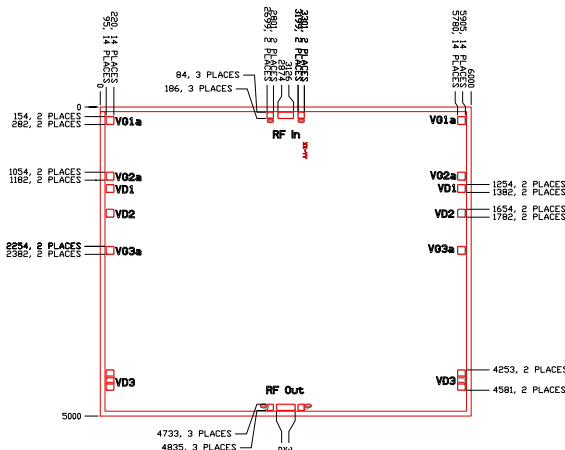

Overall die size 5000 x 6000 (+0/-50) microns, die thickness 100 (+/-10) microns.
All Gate and Drain pads must be wire bonded for electrical connection.

Pad Number	Function	Description	Pad Size (in)	Note
1	RF_IN	RF-Input pad. Matched to 50 ohm	102x252	5
2	VG1A bottom	Gate control for stage1. Vg = -2.0 to -3.5 V	128x125	1,2
3	VG1A top	Gate control for stage1. Vg = -2.0 to -3.5 V	128x125	1,2
4	VG2A bottom	Gate control for stage2. Vg = -2.0 to -3.5 V	128x125	1,2
5	VG2A top	Gate control for stage2. Vg = -2.0 to -3.5 V	128x125	1,2
6	VD1 bottom	Drain control for stage1. Vd = 40 V	128x125	1,3
7	VD1 top	Drain control for stage1. Vd = 40 V	128x125	1,3
8	VD2 bottom	Drain control for stage2. Vd = 40 V	128x125	1,4
9	VD2 top	Drain control for stage2. Vd = 40 V	128x125	1,4
10	VG3A bottom	Gate control for stage3. Vg = -2.0 to -3.5 V	128x125	1,2
11	VG3A top	Gate control for stage3. Vg = -2.0 to -3.5 V	128x125	1,2
12	VD3 bottom	Drain control for stage3. Vd = 40 V	328x125	1,4
13	VD3 top	Drain control for stage3. Vd = 40 V	328x125	1,4
14	RF_OUT	RF-Output pad. Matched to 50 ohm	102x302	5

Notes:

- ¹ Attach bypass capacitor to pads 2-13 per applications circuit
- ² VG1A&2A&3A top and bottom are connected internally, so it would be enough to connect either one for proper operation
- ³ VD1 top and bottom are not connected internally and have to be biased from both sides for proper operation
- ⁴ For current handling, it is recommended to bias VD2 and VD3 from both top and bottom sides
- ⁵ The RF Input and Output pads have a ground-signal-ground with a nominal pitch of 10 mil (250 um). The RF ground pads are 102 x 102 microns

Die Assembly Notes:

- Recommended solder is AuSn (80/20) solder. Refer to Cree's website for the Eutectic Die Bond Procedure application note at <http://www.cree.com/~media/Files/Cree/RF/Application%20Notes/Appnote%20%20Eutectic.pdf>
- Vacuum collet is the preferred method of pick-up.
- The backside of the die is the Source (ground) contact.
- Die back side gold plating is 5 microns thick minimum.
- Thermosonic ball or wedge bonding are the preferred connection methods.
- Gold wire must be used for connections.
- Use the die label (XX-YY) for correct orientation.

Part Number System

CMPA1D1E030D

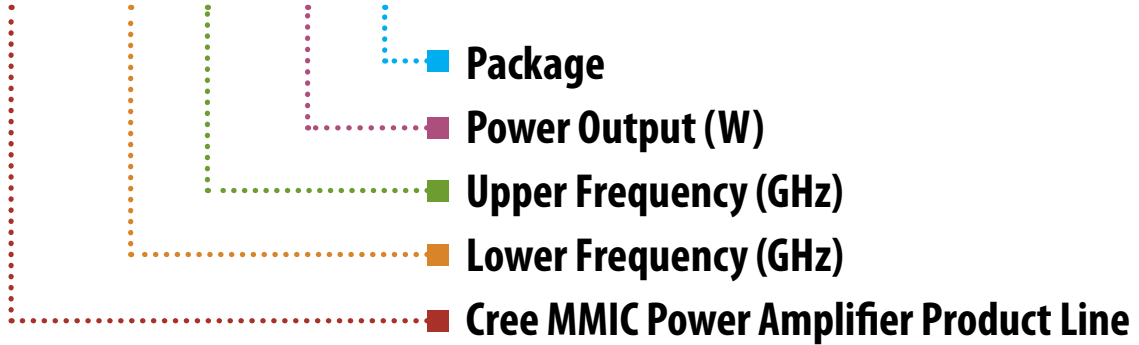

Parameter	Value	Units
Lower Frequency	13.75	GHz
Upper Frequency ¹	14.5	GHz
Power Output	30	W
Package	Bare Die	-

Table 1.

Note¹: Alpha characters used in frequency code indicate a value greater than 9.9 GHz. See Table 2 for value.

Character Code	Code Value
A	0
B	1
C	2
D	3
E	4
F	5
G	6
H	7
J	8
K	9
Examples:	1A = 10.0 GHz 2H = 27.0 GHz

Table 2.



Disclaimer

Specifications are subject to change without notice. Cree, Inc. believes the information contained within this data sheet to be accurate and reliable. However, no responsibility is assumed by Cree for its use or for any infringement of patents or other rights of third parties which may result from its use. No license is granted by implication or otherwise under any patent or patent rights of Cree. Cree makes no warranty, representation or guarantee regarding the suitability of its products for any particular purpose. "Typical" parameters are the average values expected by Cree in large quantities and are provided for information purposes only. These values can and do vary in different applications, and actual performance can vary over time. All operating parameters should be validated by customer's technical experts for each application. Cree products are not designed, intended, or authorized for use as components in applications intended for surgical implant into the body or to support or sustain life, in applications in which the failure of the Cree product could result in personal injury or death, or in applications for the planning, construction, maintenance or direct operation of a nuclear facility. CREE and the CREE logo are registered trademarks of Cree, Inc.

For more information, please contact:

Cree, Inc.
4600 Silicon Drive
Durham, North Carolina, USA 27703
www.cree.com/RF

Sarah Miller
Marketing & Export
Cree, RF Components
1.919.407.5302

Ryan Baker
Marketing
Cree, RF Components
1.919.407.7816

Tom Dekker
Sales Director
Cree, RF Components
1.919.407.5639