

CMPA801B025D

25 W, 8.0 - 11.0 GHz, GaN MMIC, Power Amplifier

Cree's CMP801B025D is a gallium nitride (GaN) High Electron Mobility Transistor (HEMT) based monolithic microwave integrated circuit (MMIC). GaN has superior properties compared to silicon or gallium arsenide, including higher breakdown voltage, higher saturated electron drift velocity and higher thermal conductivity. GaN HEMTs also offer greater power density and wider bandwidths compared to Si and GaAs transistors. This MMIC contains a two-stage reactively matched amplifier design approach enabling very wide bandwidths to be achieved.

Typical Performance Over 8.0-11.0 GHz ($T_c = 25^\circ\text{C}$)

Parameter	8.0 GHz	9.0 GHz	10.0 GHz	11.0 GHz	Units
Small Signal Gain	30	28	27	29	dB
P_{OUT} @ $P_{IN} = 25$ dBm	32	41	34	47	W
Power Gain @ $P_{IN} = 25$ dBm	20	21	20	21	dB
PAE @ $P_{IN} = 25$ dBm	41	44	37	41	%

Features

- 28 dB Small Signal Gain
- 35 W Typical P_{SAT}
- Operation up to 28 V
- High Breakdown Voltage
- High Temperature Operation
- Size 0.142 x 0.188 x 0.004 inches

Applications

- Point to Point Radio
- Communications
- Test Instrumentation
- EMC Amplifiers



Absolute Maximum Ratings (not simultaneous) at 25 °C

Parameter	Symbol	Rating	Units	Conditions
Drain-source Voltage	V_{DS}	84	V_{DC}	25 °C
Gate-source Voltage	V_{GS}	-10, +2	V_{DC}	25 °C
Storage Temperature	T_{STG}	-55, +150	°C	
Operating Junction Temperature	T_J	225	°C	
Thermal Resistance, Junction to Case (packaged) ¹	$R_{\theta JC}$	1.22	°C/W	Pulse Width = 100 μ s, Duty Cycle = 10%, $P_{DISS} = 77$ W
Thermal Resistance, Junction to Case (packaged) ¹	$R_{\theta JC}$	1.80	°C/W	CW, 85 °C, $P_{DISS} = 77$ W
Mounting Temperature (30 seconds)	T_S	320	°C	$P_{DISS} = 77$ W

Note¹ Eutectic die attach using 80/20 AuSn solder mounted to a 40 mil thick CPC carrier.

Electrical Characteristics (Frequency = 8.0 GHz to 11.0 GHz unless otherwise stated; $T_C = 25$ °C)

Characteristics	Symbol	Min.	Typ.	Max.	Units	Conditions
DC Characteristics						
Gate Threshold Voltage	$V_{GS(TH)}$	-3.8	-3.0	-2.3	V	$V_{DS} = 10$ V, $I_D = 13.2$ mA
Gate Quiescent Voltage	$V_{GS(Q)}$	-	-2.7	-	V	$V_{DD} = 28$ V, $I_{DQ} = 1200$ mA
Saturated Drain Current ¹	I_{DS}	9.2	12.9	-	A	$V_{DS} = 6.0$ V, $V_{GS} = 2.0$ V
Drain-Source Breakdown Voltage	V_{BD}	84	100	-	V	$V_{GS} = -8$ V, $I_D = 13.2$ mA
RF Characteristics²						
Small Signal Gain	S21	-	28	-	dB	$V_{DD} = 28$ V, $I_{DQ} = 1200$ mA
Power Output	P_{OUT1}	22.5	40	-	W	$V_{DD} = 28$ V, $I_{DQ} = 1200$ mA, $P_{IN} = 25$ dBm, Freq = 8 GHz
Power Output	P_{OUT1}	28.0	40	-	W	$V_{DD} = 28$ V, $I_{DQ} = 1200$ mA, $P_{IN} = 25$ dBm, Freq = 10 GHz
Power Output	P_{OUT1}	27.5	40	-	W	$V_{DD} = 28$ V, $I_{DQ} = 1200$ mA, $P_{IN} = 25$ dBm, Freq = 11 GHz
Power Added Efficiency	PAE	30	45	-	%	$V_{DD} = 28$ V, $I_{DQ} = 1200$ mA, $P_{IN} = 25$ dBm, Freq = 8 GHz
Power Added Efficiency	PAE	32	45	-	%	$V_{DD} = 28$ V, $I_{DQ} = 1200$ mA, $P_{IN} = 25$ dBm, Freq = 10 GHz
Power Added Efficiency	PAE	30	45	-	%	$V_{DD} = 28$ V, $I_{DQ} = 1200$ mA, $P_{IN} = 25$ dBm, Freq = 11 GHz
Power Gain	G_p	19.75	20	-	dB	$V_{DD} = 28$ V, $I_{DQ} = 1200$ mA, $P_{IN} = 25$ dBm, Freq = 8 GHz
Power Gain	G_p	19.55	20	-	dB	$V_{DD} = 28$ V, $I_{DQ} = 1200$ mA, $P_{IN} = 25$ dBm, Freq = 10 GHz
Power Gain	G_p	22.40	20	-	dB	$V_{DD} = 28$ V, $I_{DQ} = 1200$ mA, $P_{IN} = 25$ dBm, Freq = 11 GHz
Input Return Loss	S11	-	5	-	dB	$V_{DD} = 28$ V, $I_{DQ} = 1200$ mA
Output Return Loss	S22	-	12	-	dB	$V_{DD} = 28$ V, $I_{DQ} = 1200$ mA
Output Mismatch Stress	VSWR	-	5 : 1	-	Ψ	No damage at all phase angles, $V_{DD} = 28$ V, $I_{DQ} = 1200$ mA, $P_{OUT} = 25$ W CW

Notes:

¹ Scaled from PCM data.

² All data pulse tested on-wafer with Pulse Width = 10 μ s, Duty Cycle = 0.1%.

Die Dimensions (units in microns)

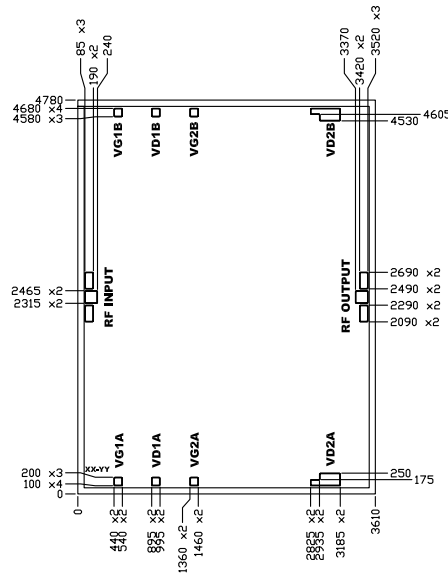

Overall die size 4780 x 3610 (+0/-50) microns, die thickness 100 (+/-10) micron.
All Gate and Drain pads must be wire bonded for electrical connection.

Pad Number	Function	Description	Pad Size (microns)	Note
1	RF-IN	RF-Input pad. Matched to 50 ohm.	150 x 150	4
2	VG1_A	Gate control for stage 1. $V_G \sim 2.0 - 3.5$ V.	100 x 100	1,2
3	VG1_B	Gate control for stage 1. $V_G \sim 2.0 - 3.5$ V.	100 x 100	1,2
4	VD1_A	Drain supply for stage 1. $V_D = 28$ V.	100 x 100	1
5	VD1_B	Drain supply for stage 1. $V_D = 28$ V.	100 x 100	1
6	VG2_A	Gate control for stage 2A. $V_G \sim 2.0 - 3.5$ V.	100 x 100	1,3
7	VG2_B	Gate control for stage 2A. $V_G \sim 2.0 - 3.5$ V.	100 x 100	1,3
8	VD2_A	Drain supply for stage 2A. $V_D = 28$ V.	-	1
9	VD2_B	Drain supply for stage 2B. $V_D = 28$ V.	-	1
10	RF-Out	RF-Output pad. Matched to 50 ohm.	150 x 150	4

Notes:

- Attach bypass capacitor to pads 2-9 per application circuit.
- VG1_A and VG1_B are connected internally so it would be enough to connect either one for proper operation.
- VG2_A and VG2_B are connected internally so it would be enough to connect either one for proper operation.
- The RF Input and Output pad have a ground-signal-ground with a nominal pitch of 1 mil (25 μ m). The RF ground pads are 100 x 200 microns.

Die Assembly Notes:

- Recommended solder is AuSn (80/20) solder. Refer to Cree's website for the Eutectic Die Bond Procedure application note at http://www.cree.com/products/wireless_appnotes.asp
- Vacuum collet is the preferred method of pick-up.
- The backside of the die is the Source (ground) contact.
- Die back side gold plating is 5 microns thick minimum.
- Thermosonic ball or wedge bonding are the preferred connection methods.
- Gold wire must be used for connections.
- Use the die label (XX-YY) for correct orientation.

Block Diagram Showing Additional Capacitors for Operation Over 8.0 to 11.0 GHz

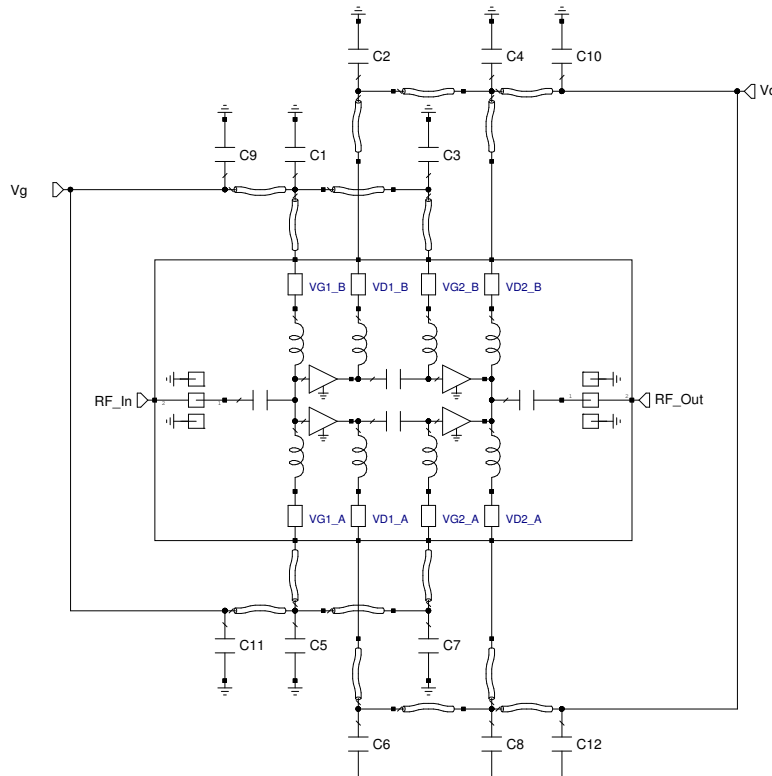

Designator	Description	Quantity
C1,C2,C3,C4,C5,C6,C7,C8	CAP, 51pF, +/-10%, SINGLE LAYER, 0.035", Er 3300, 100V, Ni/Au TERMINATION	8
C9,C10,C11,C12	CAP, 680pF, +/-10%, SINGLE LAYER, 0.070", Er 3300, 100V, Ni/Au TERMINATION	4

Notes:

¹ The input, output and decoupling capacitors should be attached as close as possible to the die- typical distance is 5 to 10 mils with a maximum of 15 mils.

² The MMIC die and capacitors should be connected with 2 mil gold bond wires.



Typical Performance of the CMPA801B025D

Small Signal Gain vs Frequency
 $V_{DD} = 28\text{ V}$, $I_{DQ} = 1.2\text{ A}$

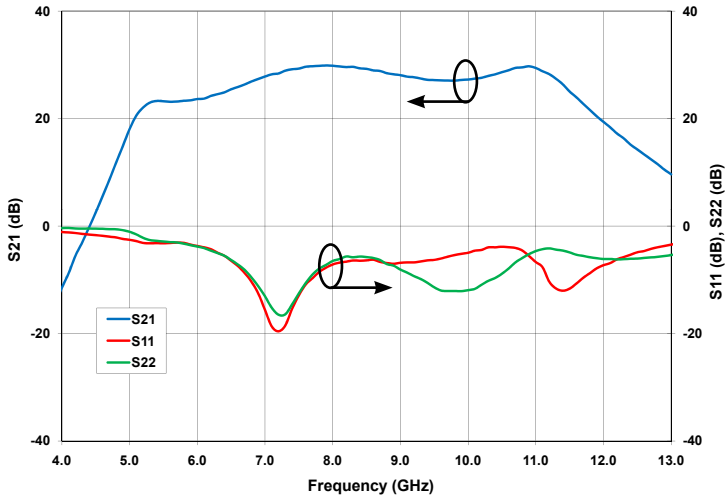

Output Power & PAE vs Frequency
 $V_{DD} = 28\text{ V}$, $I_{DQ} = 1.2\text{ A}$, $P_{IN} = 25\text{ dBm}$

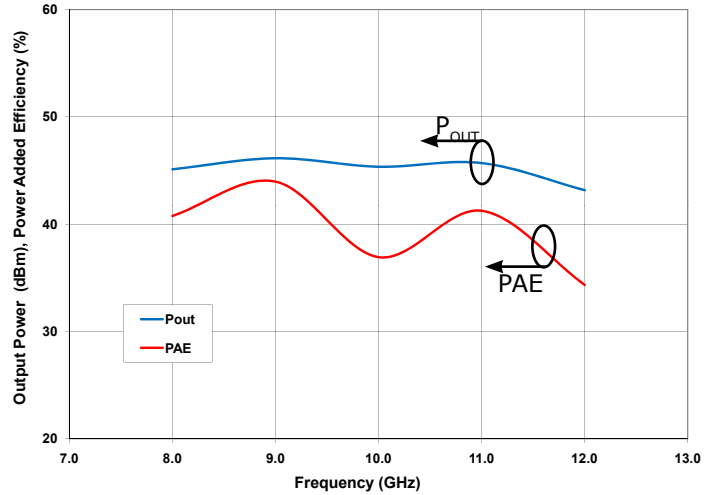

Associated Gain vs Frequency
 $V_{DD} = 28\text{ V}$, $I_{DQ} = 1.2\text{ A}$, $P_{IN} = 25\text{ dBm}$

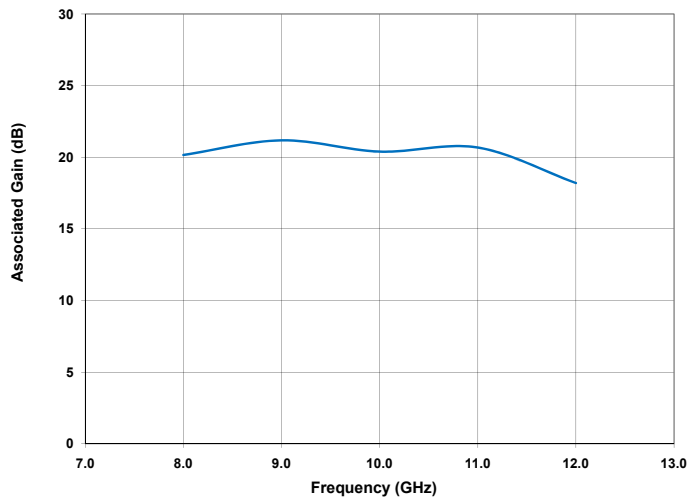

Part Number System

CMPA801B025D

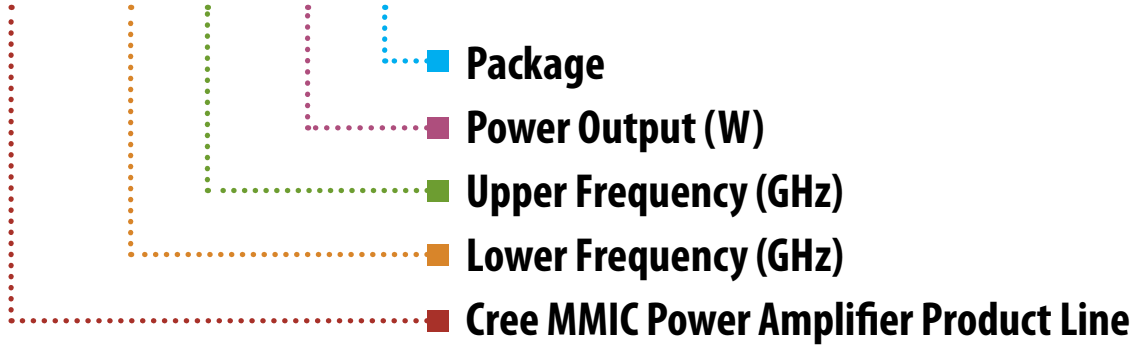

Parameter	Value	Units
Lower Frequency	8.0	GHz
Upper Frequency ¹	11.0	GHz
Power Output	25	W
Package	Bare Die	-

Table 1.

Note¹: Alpha characters used in frequency code indicate a value greater than 9.9 GHz. See Table 2 for value.

Character Code	Code Value
A	0
B	1
C	2
D	3
E	4
F	5
G	6
H	7
J	8
K	9
Examples:	1A = 10.0 GHz 2H = 27.0 GHz

Table 2.



Disclaimer

Specifications are subject to change without notice. Cree, Inc. believes the information contained within this data sheet to be accurate and reliable. However, no responsibility is assumed by Cree for its use or for any infringement of patents or other rights of third parties which may result from its use. No license is granted by implication or otherwise under any patent or patent rights of Cree. Cree makes no warranty, representation or guarantee regarding the suitability of its products for any particular purpose. "Typical" parameters are the average values expected by Cree in large quantities and are provided for information purposes only. These values can and do vary in different applications, and actual performance can vary over time. All operating parameters should be validated by customer's technical experts for each application. Cree products are not designed, intended, or authorized for use as components in applications intended for surgical implant into the body or to support or sustain life, in applications in which the failure of the Cree product could result in personal injury or death, or in applications for the planning, construction, maintenance or direct operation of a nuclear facility. CREE and the CREE logo are registered trademarks of Cree, Inc.

For more information, please contact:

Cree, Inc.
4600 Silicon Drive
Durham, North Carolina, USA 27703
www.cree.com/wireless

Sarah Miller
Marketing & Export
Cree, RF Components
1.919.407.5302

Ryan Baker
Marketing
Cree, RF Components
1.919.407.7816

Tom Dekker
Sales Director
Cree, RF Components
1.919.313.5639