

**250mA CMOS Low Dropout Voltage Low consumption Regulator**

# LR8503

**Features :**

- Low Power Consumption : 3.0uA ( Typ. )
- Maximum Output Current : 250mA
- Small Dropout Voltage :  
170mV@100mA (Vout=3.0V)  
400mV@250mA (Vout=3.0V)
- Input Voltage Range : 1.5V ~ 10V
- Output Voltage Range : 1.2V~6.0V  
( customized on command in 0.1V steps )
- Highly Accurate :  $\pm 2\%$ (  $\pm 1\%$  customized )
- Output Current Limit

**Applications :**

- Battery Powered equipment
- Power Management of MP3、 PDA、 DSC、 Mouse、 PS2 Games
- Reference Voltage Source
- Regulation after Switching Power

**Outline :**

LR8503 series is a group of positive voltage output, low power consumption, low dropout voltage, three terminal regulator. It can provide 250mA output current when input / output voltage differential drops to 400mV ( Vin =4.0V、 Vout=3.0V ) 。 The very low power consumption of LR8503 ( Iq=3.0uA ) can greatly improve natural life of batteries.

LR8503 can provide output value in the range of 1.2V~6.0V in 0.1V steps. It also can customized on command.

LR8503 includes high accuracy voltage reference, error amplifier, current limit circuit and output driver module.

LR8503 has well load transient response and good temperature characteristic, which can assure the stability of chip and power system. And it uses trimming technique to guarantee output voltage accuracy within  $\pm 2\%$ .

LR8503 is available in SOT-89-3、 SOT-23-3 packages which is lead free , it also can available in these packages with lead.

**LR8503 Typical Application Circuit**

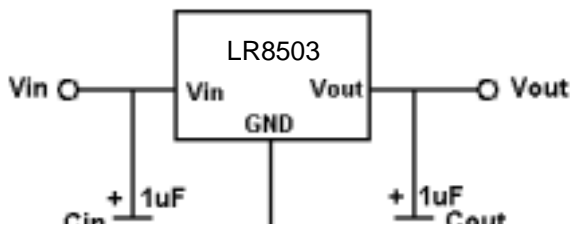

**Application hints :**

NOTE1 : Input capacitor (Cin=1uF) is recommended in all application circuit. Tantalum capacitor is recommended.

NOTE2 : Output capacitor (Cout=1uF) is recommended in all application to assure the stability of circuit. Tantalum capacitor is recommended.

**LR8503 Typical Performance Characteristic :**

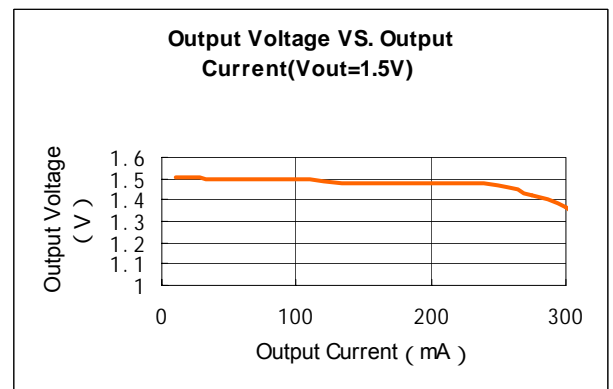

**Selection Guide :**

LR8503-XX X X X

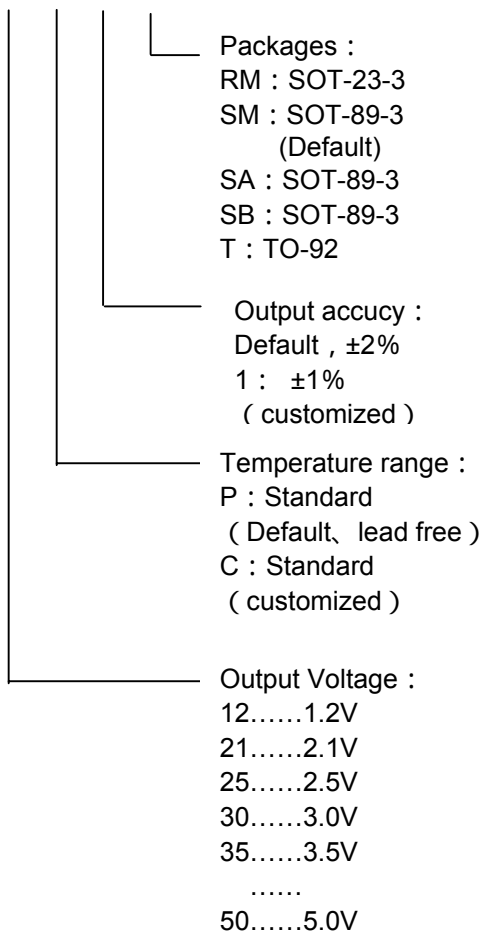

**Pin Assignment :**

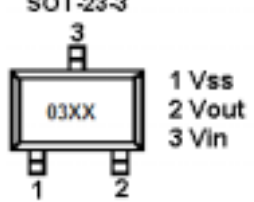
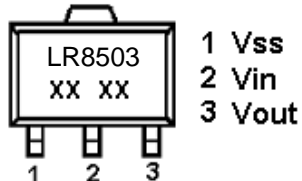
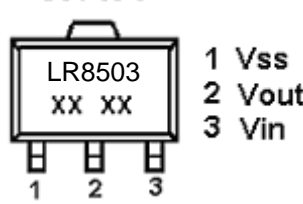
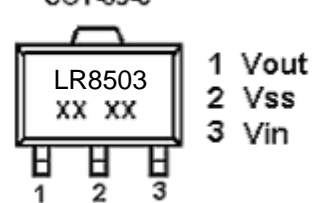
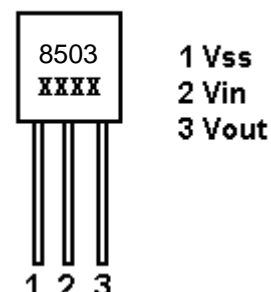
Product Classification	Pin Configuration
LR8503- PRM	<p>SOT-23-3</p> 
LR8503- PSM	<p>SOT-89-3</p> 
LR8503- PSA	<p>SOT-89-3</p> 
LR8503- PSB	<p>SOT-89-3</p> 
LR8503- PT	<p>TO-92</p> 

**Pin Description :**

Pin number				PIN Name	Function
SOT-23-3	SOT-89-3 (SM)	SOT-89-3 (SA)	SOT-89-3 (SB)		
1	1	1	2	<b>Vss</b>	Ground
3	2	3	3	<b>Vin</b>	Supply voltage input
2	3	2	1	<b>Vout</b>	Output Voltage
-	-	-	-	<b>NC</b>	No connect
-	-	-	-	<b>NC</b>	No connect

**Product Classification :**

Product Name	Output Voltage	Package Type	Package Marking
LR8503-12PRM	1.2V	SOT-23-3	<div style="border: 1px solid black; padding: 5px; display: inline-block;">           03XX  <hr style="width: 50%; margin: 0 auto;"/>           1         </div> 1 Output voltage
LR8503-15PRM	1.5V	SOT-23-3	
LR8503-21PRM	2.1V	SOT-23-3	
LR8503-25PRM	2.5V	SOT-23-3	
LR8503-30PRM	3.0V	SOT-23-3	
-----	-----	SOT-23-3	
LR8503-50PRM	5.0V	SOT-23-3	<div style="border: 1px solid black; padding: 5px; display: inline-block;">           LR8503            XX XX  <hr style="width: 50%; margin: 0 auto;"/>           1 2         </div> 1 Output voltage 2 Lot No.
LR8503-12PSM	1.2V	SOT-89-3	
LR8503-15PSM	1.5V	SOT-89-3	
LR8503-21PSM	2.1V	SOT-89-3	
LR8503-25PSM	2.5V	SOT-89-3	
LR8503-30PSM	3.0V	SOT-89-3	
-----	-----	SOT-89-3	
LR8503-50PSM	5.0V	SOT-89-3	<div style="border: 1px solid black; padding: 5px; display: inline-block;">           LR8503            XX XX  <hr style="width: 50%; margin: 0 auto;"/>           1 2         </div> 1 Output voltage 2 Lot No.
LR8503-12PSA	1.2V	SOT-89-3	
LR8503-15PSA	1.5V	SOT-89-3	
LR8503-21PSA	2.1V	SOT-89-3	
LR8503-25PSA	2.5V	SOT-89-3	
LR8503-30PSA	3.0V	SOT-89-3	
-----	-----	SOT-89-3	
LR8503-50PSA	5.0V	SOT-89-3	<div style="border: 1px solid black; padding: 5px; display: inline-block;">           LR8503            XX XX  <hr style="width: 50%; margin: 0 auto;"/>           1 2         </div> 1 Output voltage 2 Lot No.
LR8503-12PSB	1.2V	SOT-89-3	
LR8503-15PSB	1.5V	SOT-89-3	
LR8503-21PSB	2.1V	SOT-89-3	
LR8503-25PSB	2.5V	SOT-89-3	
LR8503-30PSB	3.0V	SOT-89-3	
-----	-----	SOT-89-3	
LR8503-50PSB	5.0V	SOT-89-3	<div style="border: 1px solid black; padding: 5px; display: inline-block;">           LR8503            XX XX  <hr style="width: 50%; margin: 0 auto;"/>           1 2         </div> 1 Output voltage 2 Lot No.
LR8503-12PT	1.2V	TO-92	
LR8503-15PT	1.5V	TO-92	
LR8503-21PT	2.1V	TO-92	
LR8503-25PT	2.5V	TO-92	
LR8503-30PT	3.0V	TO-92	
-----	-----	TO-92	
LR8503-50PT	5.0V	TO-92	

**Block Diagram :**

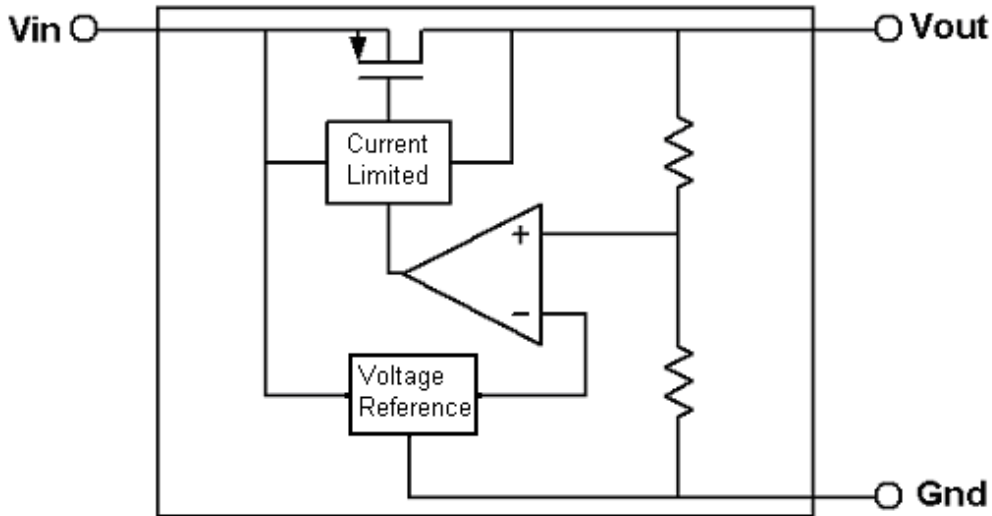

**Absolute Maximum Ratings :**

Max input voltage-----	10V
Junction Temperature (T <sub>J</sub> ) -----	125°C
Ambient Temperature(T <sub>A</sub> )-----	-40°C ~ 85°C
Power Dissipation	
SOT-23-3 -----	0.15W
SOT-23-5 -----	0.25W
SOT-89-3 -----	0.5W
Storage Temperature(T <sub>s</sub> ) -----	-45°C ~ 150°C
Lead Temperature and Time -----	260°C,10S

**Recommended Work Conditions :**

Item	Min	Recommended	Max	unit
Input Voltage Range			8	V
Ambient Temperature	-40		+125	°C

**Electrical Characteristics :**

( Test Conditions : C<sub>in</sub>=1uF,C<sub>out</sub>=1uF,T<sub>A</sub>=25°C, unless otherwise specified. )

LR8503-1.5V

Symbol	Parameter	Conditions	Min	Typ	Max	Units
V <sub>in</sub>	Input Voltage				8	V
V <sub>out</sub>	Output Voltage		1.47	1.5	1.53	V
I <sub>out</sub> (Max.)	Maximum Output Current	V <sub>in</sub> =2.5V,V <sub>out</sub> >1.47	250			mA
Dropout Voltage	Input-Output Voltage Differential	I <sub>out</sub> =100mA		270	400	mV
$\frac{\Delta V_{out}}{\Delta V_{in} \cdot V_{out}}$	Line Regulation	I <sub>out</sub> =40mA 1.6V≤V <sub>in</sub> ≤8V		0.2	0.3	%/V
$\Delta V_{out}$	Load Regulation	V <sub>in</sub> =2.5V 1mA≤I <sub>out</sub> ≤100mA		20	40	mV
I <sub>q</sub>	Quiescent Current	V <sub>in</sub> =2.5V		3.0	5.0	uA

$\frac{\Delta V_{out}}{\Delta T \cdot V_{out}}$	Output Voltage Temperature Coefficient	$I_{out}=10mA$		50		ppm/°C
---	--	----------------	--	----	--	--------

LR8503-3.0V

Symbol	Parameter	Conditions	Min	Typ	Max	Units
$V_{in}$	Input Voltage				8	V
$V_{out}$	Output Voltage		2.94	3.0	3.06	V
$I_{out(Max.)}$	Maximum Output Current	$V_{in}=4V, V_{out}>2.94V$	250			mA
Dropout Voltage	Input-Output Voltage Differential	$I_{out}=100mA$		170	300	mV
		$I_{out}=200mA$		320	500	
$\frac{\Delta V_{out}}{\Delta V_{in} \cdot V_{out}}$	Line Regulation	$I_{out}=40mA$ $3.2V \leq V_{in} \leq 8V$		0.2	0.3	%/V
$\Delta V_{out}$	Load Regulation	$V_{in}=4.0V$ $1mA \leq I_{out} \leq 100mA$		20	40	mV
$I_q$	Quiescent Current	$V_{in}=4V$		3.0	5.0	uA
$\frac{\Delta V_{out}}{\Delta T \cdot V_{out}}$	Output Voltage Temperature Coefficient	$I_{out}=10mA$		50		ppm/°C

Typical Application Circuit :

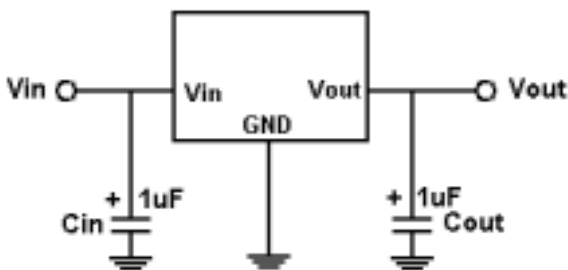

Application hints :

NOTE1 : Input capacitor ( $C_{in}=1\mu F$ ) is recommended in all application circuit. Tantalum capacitor is recommended.

NOTE2 : Output capacitor ( $C_{out}=1\mu F$ ) is recommended in all application to assure the stability of circuit. Tantalum capacitor is recommended.

Explanation :

LR8503 is a series of low dropout voltage and low power consumption three pins regulator. Its application circuit is very simple, which only needs two outside capacitors. It is composed of these modules: high accuracy voltage reference, current limit circuit, error amplifier, output driver and power transistor.

Current Limit module can keep chip and power system away from danger when load current is more than 250mA.

LR8503 uses trimming technique to assure the accuracy of output value within  $\pm 2\%$ , at the same time, temperature compensated is elaborately considered in this chip, which makes LR8503's temperature coefficient within 50ppm/°C.

## Typical Performance Characteristics :

### 1. Load regulation

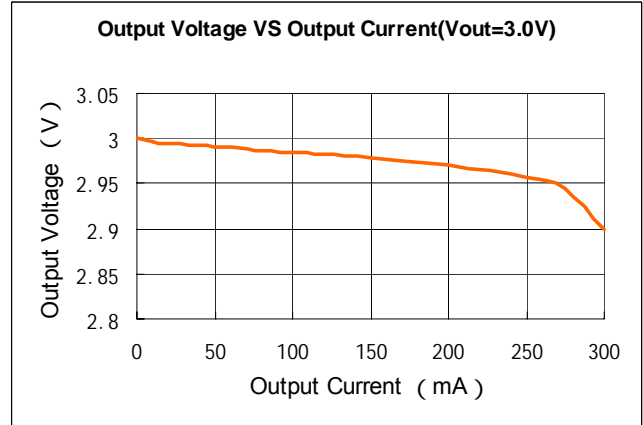
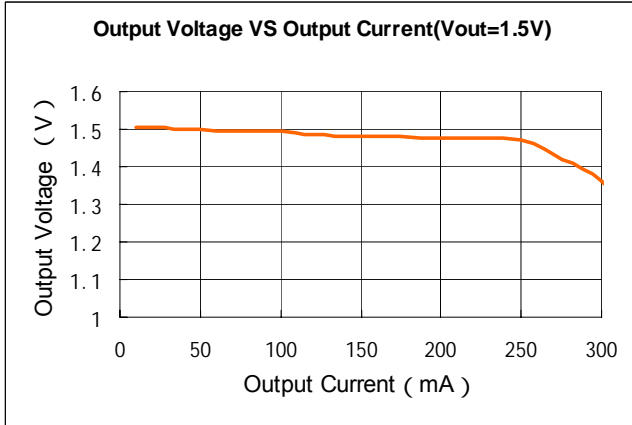

### 2. Line Regulation

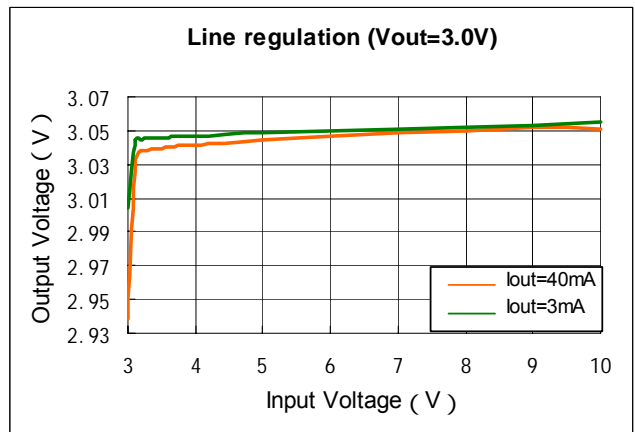
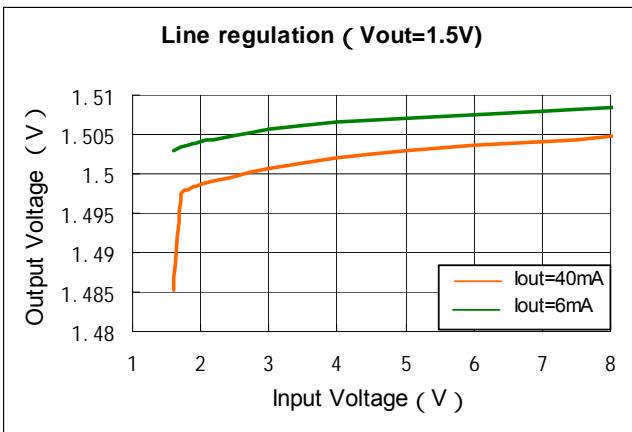

### 3. Dropout Voltage

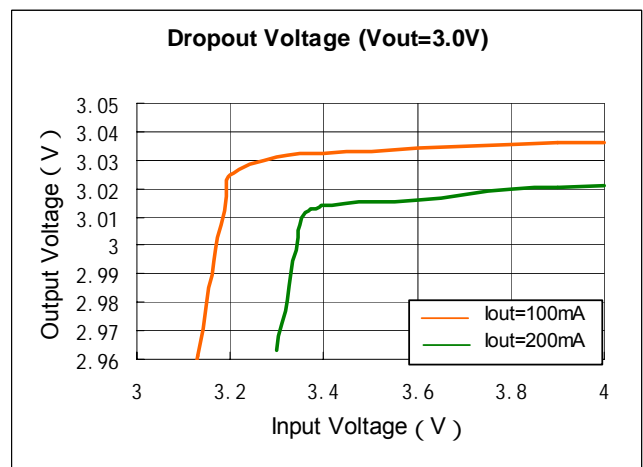
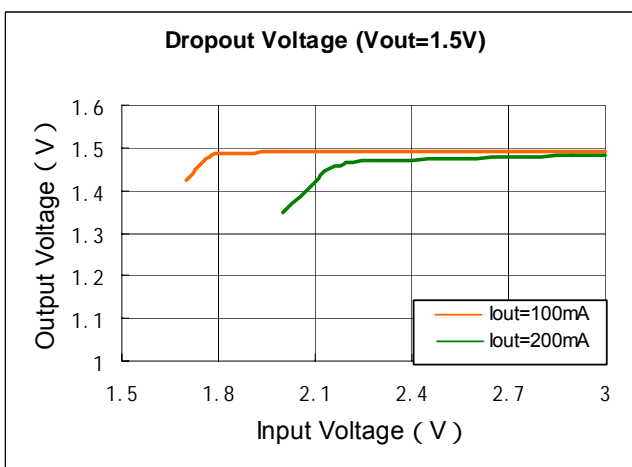

4 . Input Voltage transient response  
(  $V_{out}=1.5V, I_{out}=10mA$  )

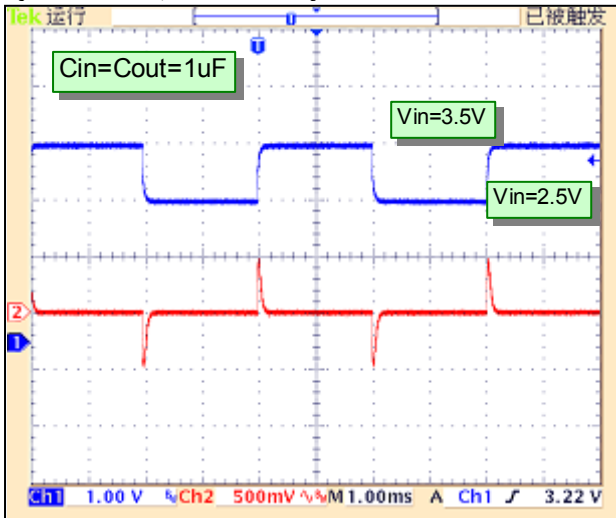

Input Voltage transient response  
(  $V_{out}=3.0V, I_{out}=10mA$  )

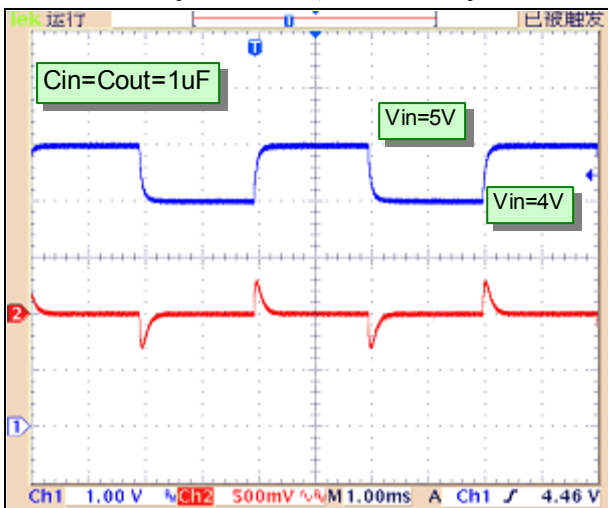

Input Voltage transient response  
(  $V_{out}=1.5V, I_{out}=1mA$  )

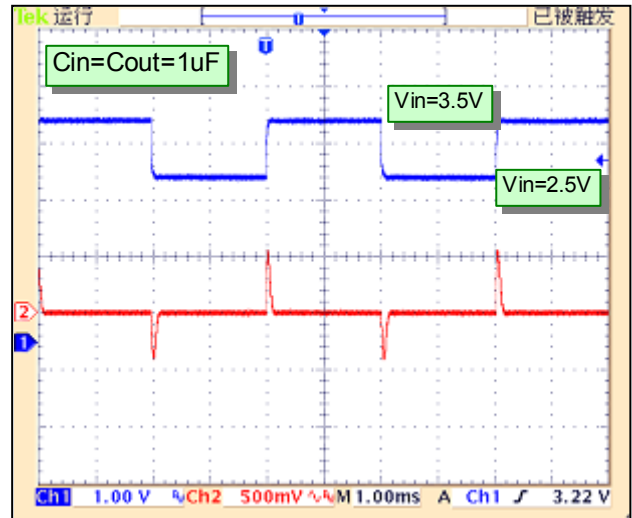

Input Voltage transient response  
(  $V_{out}=3.0V, I_{out}=1mA$  )

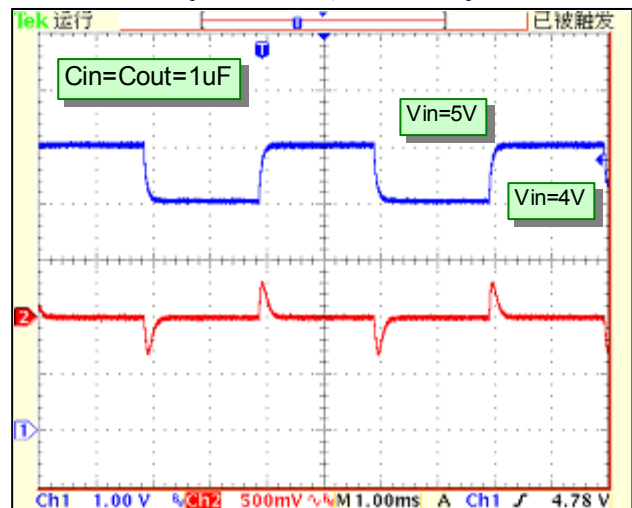

5 . Load transient response (  $V_{out}=1.5V$  )

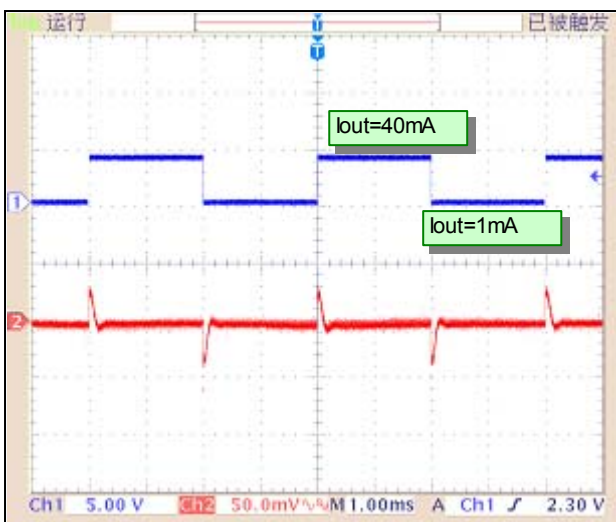

Load transient response (  $V_{out}=3.0V$  )

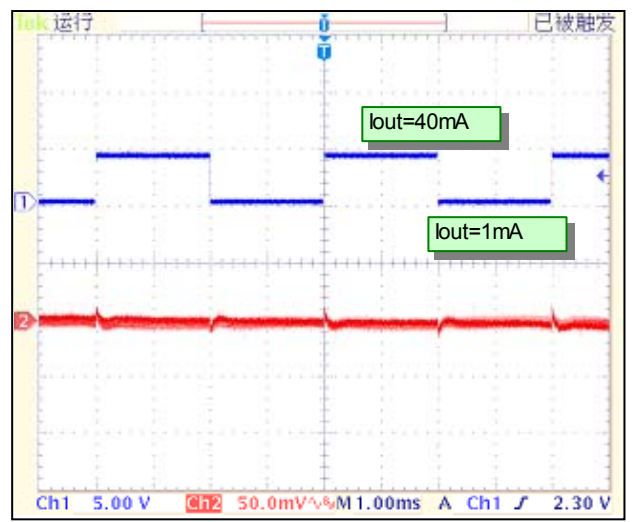

**Package Outline :**

Package	SOT-89-3	Devices per reel	1000	Unit	mm
---------	----------	------------------	------	------	----

Package Dimension:

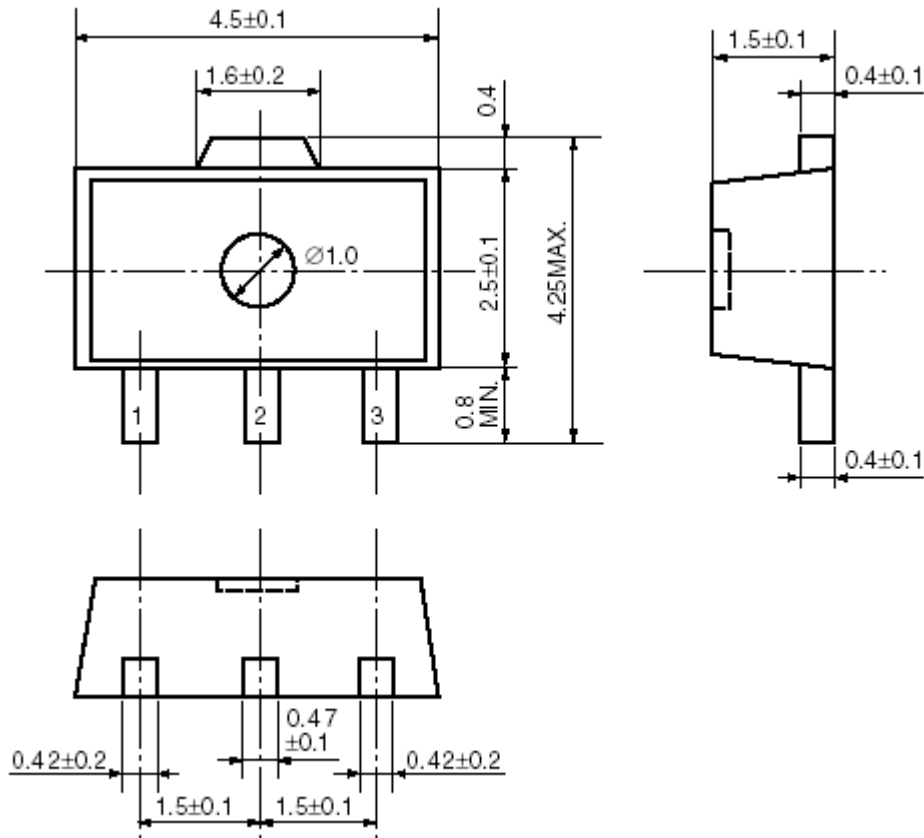

Taping Specification: ( M1 : Standard Type , M2 : Customized )

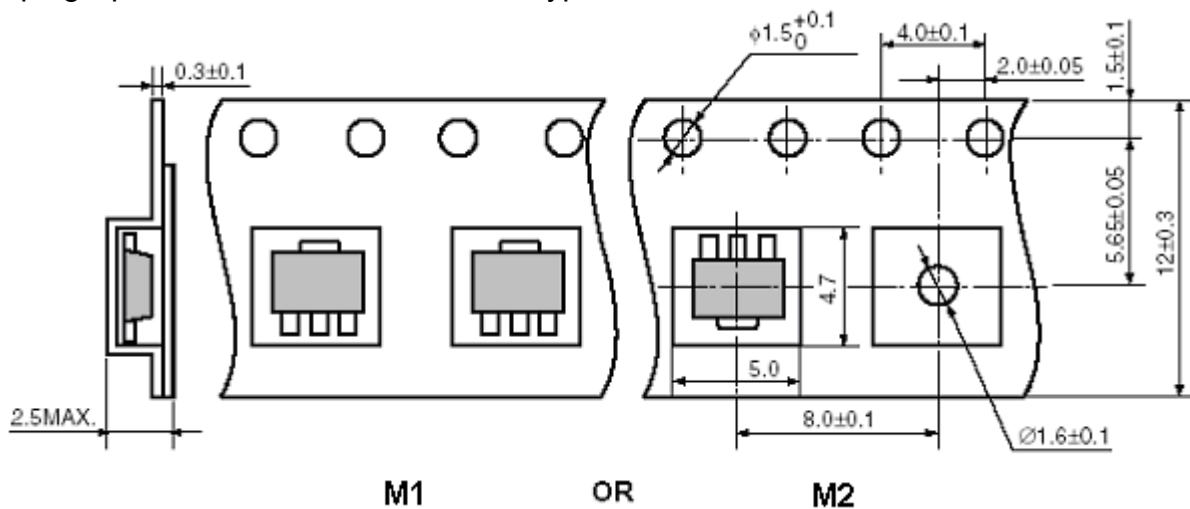



Taping Reel Dimension :

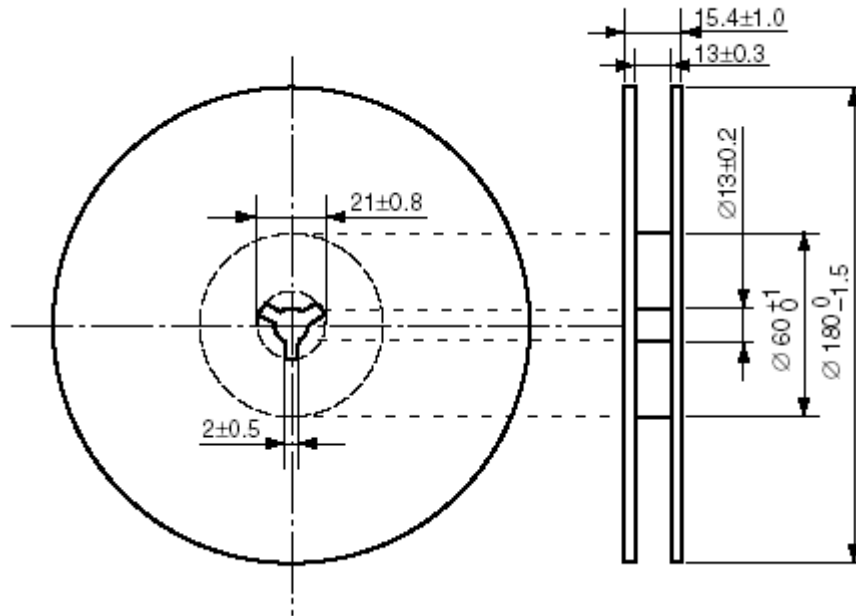

**SOT-23-3:**

Package	SOT-23-3	Devices per reel	3000	Unit	mm
---------	----------	------------------	------	------	----

Package dimension :

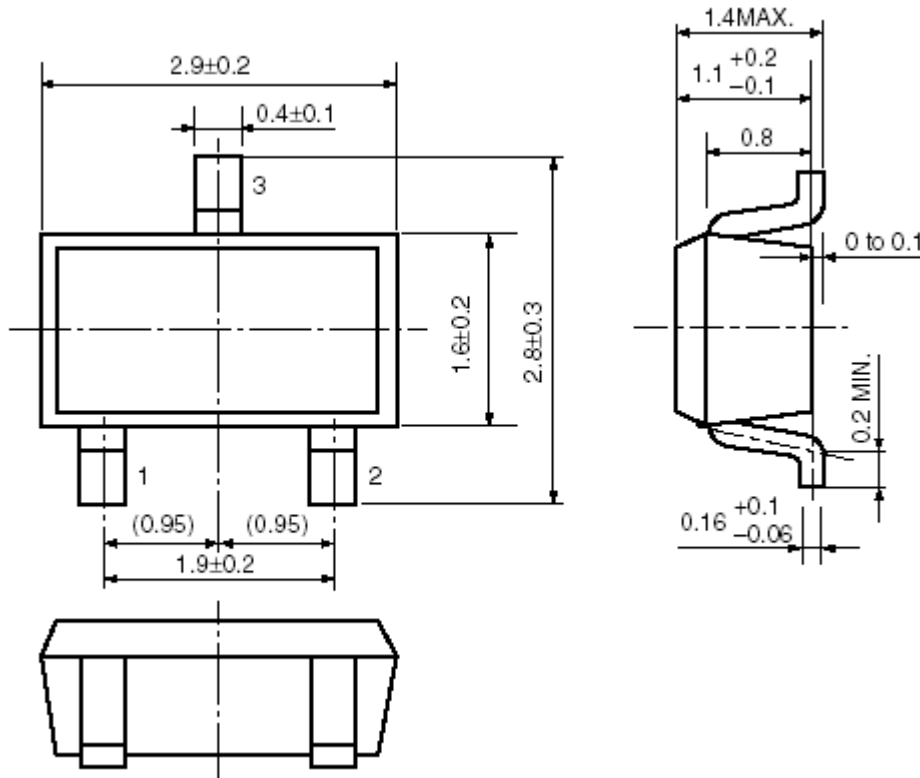

Taping Specification :

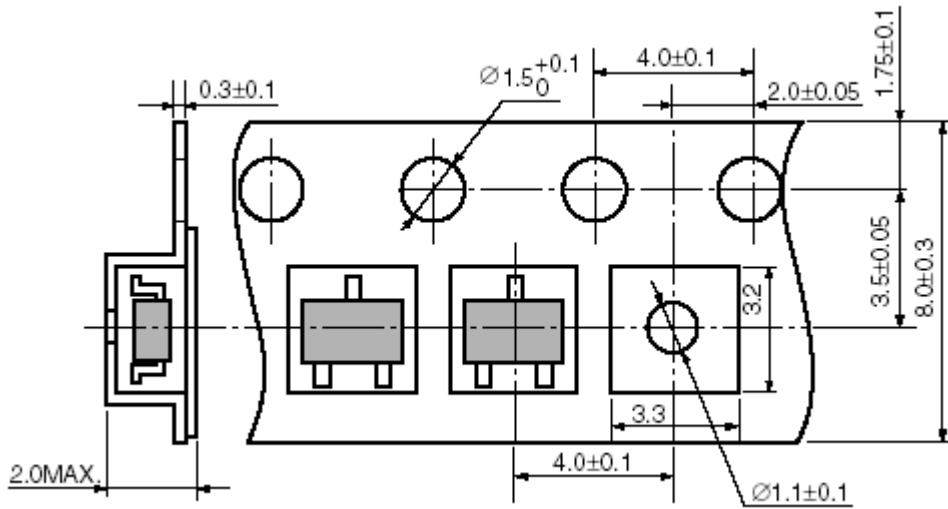

Taping reel dimension :

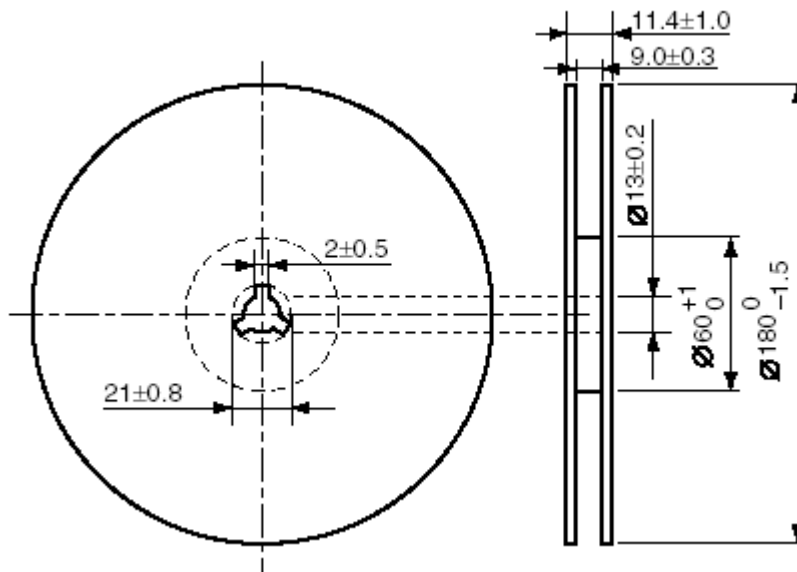

**SOT-23-5:**

Package	SOT-23-5	Devices per reel	3000	Unit	mm
---------	----------	------------------	------	------	----

Package specification :

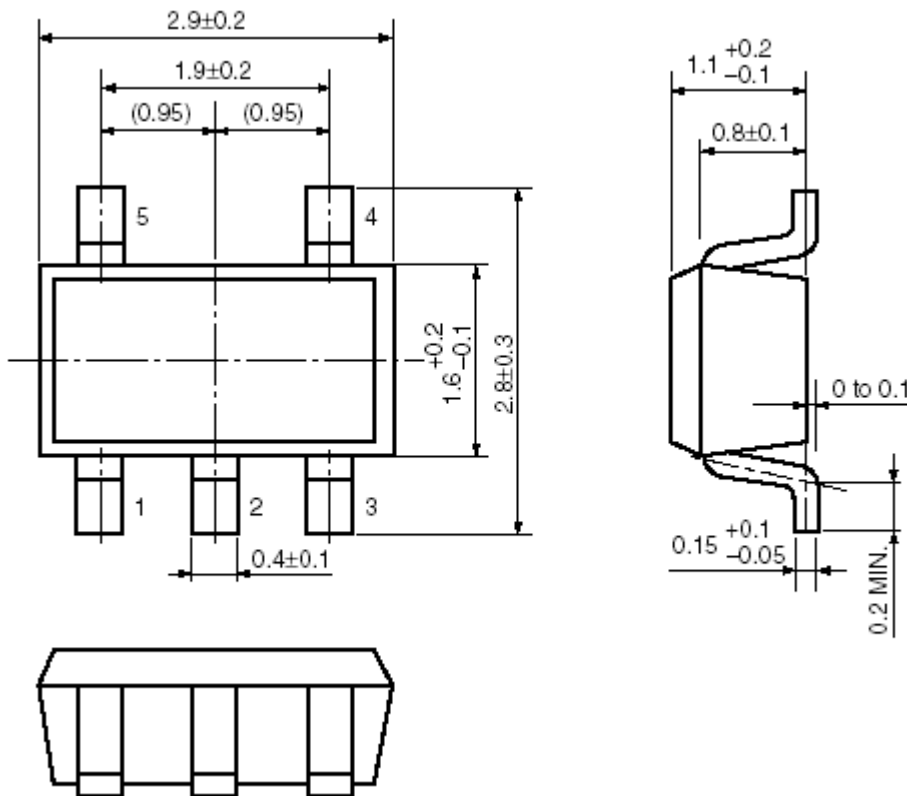

Taping dimension : ( M1 : Standard Type , M2 : Customized )

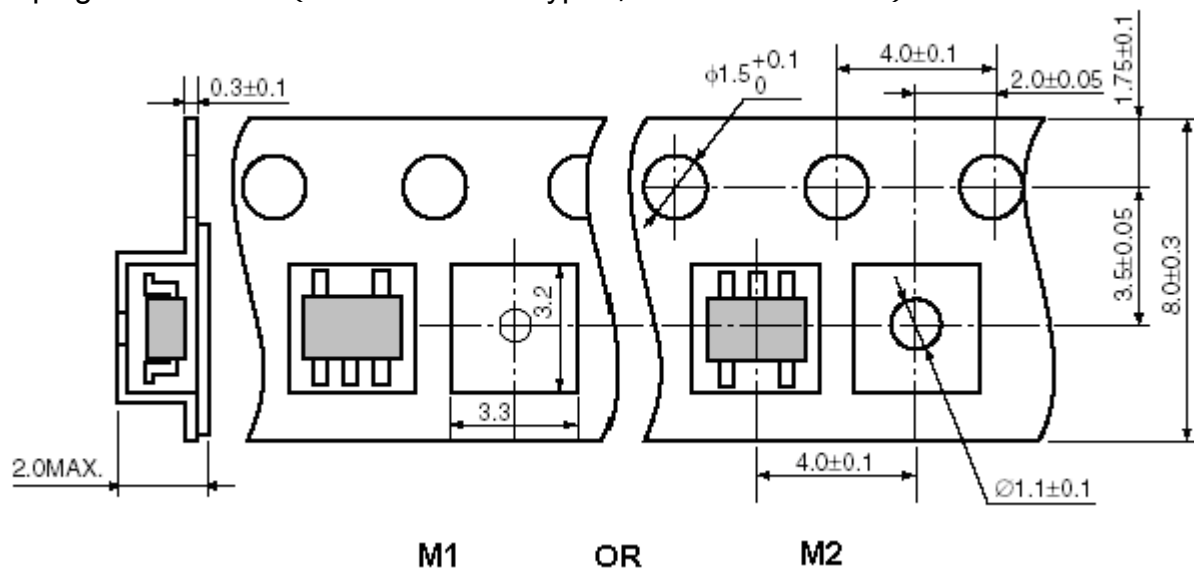

Taping reel dimension :

