

UT54ACS02E/UT54ACTS02E

Quadruple 2-Input NOR Gate

July, 2013

www.aeroflex.com/Logic



FEATURES

- 0.6µm CRH CMOS Process
 - Latchup immune
- High speed
- Low power consumption
- Wide power supply operating range of 3.0V to 5.5V
- Available QML Q or V processes
- 14-lead flatpack
- UT54ACS02E - SMD - 5962-96514
- UT54ACTS02E - SMD - 5962-96515

DESCRIPTION

The UT54ACS02E and UT54ACTS02E are quadruple, two-input NOR gates. The circuits perform the Boolean functions $Y = \overline{A + B}$ or $Y = \overline{A} \cdot \overline{B}$ in positive logic.

The devices are characterized over the full HiRel temperature range of -55°C to +125°C.

FUNCTION TABLE

INPUTS		OUTPUT
A	B	Y
H	X	L
X	H	L
L	L	H

LOGIC SYMBOL

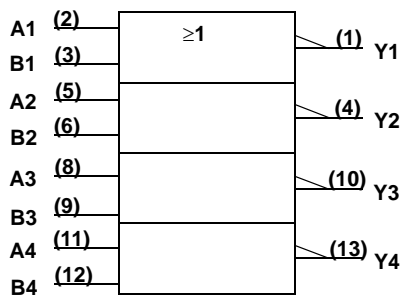

PINOUT

14-Lead Flatpack
Top View

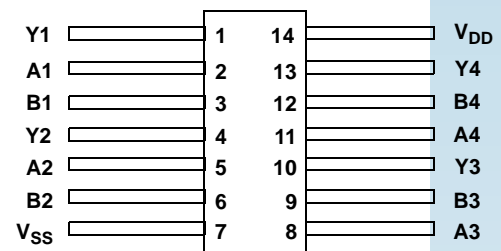

LOGIC DIAGRAM

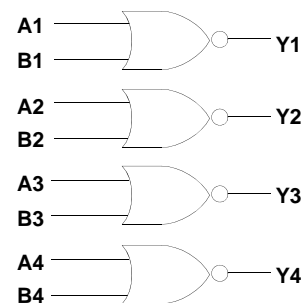

Note:

1. Logic symbol in accordance with ANSI/IEEE standard 91-1984 and IEC Publication 617-12.

OPERATIONAL ENVIRONMENT¹

PARAMETER	LIMIT	UNITS
Total Dose	1.0E6	rads(Si)
SEU Threshold ²	108	MeV-cm ² /mg
SEL Immune	120	MeV-cm ² /mg
Neutron Fluence	1.0E14	n/cm ²

Notes:

1. Logic will not latchup during radiation exposure within the limits defined in the table.
2. Device storage elements are immune to SEU affects.

ABSOLUTE MAXIMUM RATINGS¹

SYMBOL	PARAMETER	LIMIT	UNITS
V _{DD}	Supply voltage	-0.3 to 7.0	V
V _{I/O}	Voltage any pin	-0.3 to V _{DD} + 0.3	V
T _{STG}	Storage Temperature range	-65 to +150	°C
T _J	Maximum junction temperature	+175	°C
T _{LS}	Lead temperature (soldering 5 seconds)	+300	°C
Θ _{JC}	Thermal resistance junction to case	15.5	°C/W
I _I	DC input current	±10	mA
P _D ²	Maximum package power dissipation permitted @ T _c =125°C	3.2	W

Note:

1. Stresses outside the listed absolute maximum ratings may cause permanent damage to the device. This is a stress rating only, functional operation of the device at these or any other conditions beyond limits indicated in the operational sections is not recommended. Exposure to absolute maximum rating conditions for extended periods may affect device reliability.
2. Per MIL-STD-883, method 1012.1, Section 3.4.1, $P_D = (T_{j(max)} - T_{c(max)}) / \Theta_{jc}$

RECOMMENDED OPERATING CONDITIONS

SYMBOL	PARAMETER	LIMIT	UNITS
V _{DD}	Supply voltage	3.0 to 5.5	V
V _{IN}	Input voltage any pin	0 to V _{DD}	V
T _C	Temperature range	-55 to + 125	°C

DC ELECTRICAL CHARACTERISTICS FOR THE UT54ACS02E⁷($V_{DD} = 3.0V$ to $5.5V$; $V_{SS} = 0V$ ⁶; $-55^{\circ}C < T_C < +125^{\circ}C$)

SYMBOL	DESCRIPTION	CONDITION	MIN	MAX	UNIT
V_{IL}	Low-level input voltage ¹	V_{DD} from 3.0V to 5.5V		$0.3 V_{DD}$	V
V_{IH}	High-level input voltage ¹	V_{DD} from 3.0V to 5.5V	$0.7 V_{DD}$		V
I_{IN}	Input leakage current	$V_{IN} = V_{DD}$ or V_{SS}	-1	1	μA
V_{OL}	Low-level output voltage ³	$I_{OL} = 100\mu A$ V_{DD} from 3.0V to 5.5V		0.25	V
V_{OH}	High-level output voltage ³	$I_{OH} = -100\mu A$ V_{DD} from 3.0V to 5.5V	$V_{DD} - 0.25$		V
I_{OS1}	Short-circuit output current ^{2,4}	$V_O = V_{DD}$ and V_{SS} , V_{DD} from 4.5V to 5.5V	-200	200	mA
I_{OS2}	Short-circuit output current ^{2,4}	$V_O = V_{DD}$ and V_{SS} , V_{DD} from 3.0V to 3.6V	-100	100	mA
I_{OL1}	Low level output current (sink) ⁹	$V_{IN} = V_{DD}$ or V_{SS} $V_{OL} = 0.4V$ V_{DD} from 4.5V to 5.5V	8		mA
I_{OL2}	Low level output current (sink) ⁹	$V_{IN} = V_{DD}$ or V_{SS} $V_{OL} = 0.4V$ V_{DD} from 3.0V to 3.6V	6		mA
I_{OH1}	High level output current (source) ⁹	$V_{IN} = V_{DD}$ or V_{SS} $V_{OH} = V_{DD} - 0.4V$ V_{DD} from 4.5V to 5.5V	-8		mA
I_{OH2}	High level output current (source) ⁹	$V_{IN} = V_{DD}$ or V_{SS} $V_{OH} = V_{DD} - 0.4V$ V_{DD} from 3.0V to 3.6V	-6		mA
P_{total1}	Power dissipation ^{2,8}	$C_L = 50pF$, $V_{DD} = 4.5V$ to $5.5V$		1.8	mW/ MHz
P_{total2}	Power dissipation ^{2,8}	$C_L = 50pF$, $V_{DD} = 3.0V$ to $3.6V$		0.72	mW/ MHz
I_{DDQ}	Quiescent Supply Current	$V_{IN} = V_{DD}$ or V_{SS} , V_{DD} from 3.0V to 5.5V		10	μA
C_{IN}	Input capacitance ⁵	$f = 1MHz$, $V_{DD} = 0V$		15	pF
C_{OUT}	Output capacitance ⁵	$f = 1MHz$, $V_{DD} = 0V$		15	pF

Notes:

1. Functional tests are conducted in accordance with MIL-STD-883 with the following input test conditions: $V_{IH} = V_{IH(min)} + 20\%$, $- 0\%$; $V_{IL} = V_{IL(max)} + 0\%$, $- 50\%$, as specified herein, for TTL, CMOS, or Schmitt compatible inputs. Devices may be tested using any input voltage within the above specified range, but are guaranteed to $V_{IH(min)}$ and $V_{IL(max)}$.
2. Supplied as a design limit but not guaranteed or tested.
3. Per MIL-PRF-38535, for current density $\leq 5.0E5$ amps/cm², the maximum product of load capacitance (per output buffer) times frequency should not exceed 3,765pF/MHz.
4. Not more than one output may be shorted at a time for maximum duration of one second.
5. Capacitance measured for initial qualification and when design changes may affect the value. Capacitance is measured between the designated terminal and V_{SS} at frequency of 1MHz and a signal amplitude of 50mV rms maximum.
6. Maximum allowable relative shift equals 50mV.
7. All specifications valid for the maximum radiation dose available for the respective device types.
8. Power dissipation specified per switching output.
9. Guaranteed by characterization, but not tested.

AC ELECTRICAL CHARACTERISTICS FOR THE UT54ACS02E²

($V_{DD} = 3.0V$ to $5.5V$; $V_{SS} = 0V$ ¹, $-55^{\circ}C < T_C < +125^{\circ}C$)

SYMBOL	PARAMETER	CONDITION	V_{DD}	MINIMUM	MAXIMUM	UNIT
t_{PLH}	Input to Y_n	$C_L = 50pF$	3.0V to 3.6V	1	15	ns
			4.5V to 5.5V	1	7	
t_{PHL}	Input to Y_n	$C_L = 50pF$	3.0V to 3.6V	1	17	ns
			4.5V to 5.5V	1	6	

Notes:

1. Maximum allowable relative shift equals 50mV.
2. All specifications valid for the maximum radiation dose available for the respective device types.

DC ELECTRICAL CHARACTERISTICS FOR THE UT54ACTS02E⁷

($V_{DD} = 3.0V$ to $5.5V$; $V_{SS} = 0V$ ⁶; $-55^{\circ}C < T_C < +125^{\circ}C$)

SYMBOL	DESCRIPTION	CONDITION	MIN	MAX	UNIT
V_{IL1}	Low-level input voltage ¹	V_{DD} from 4.5V to 5.5V		0.8	V
V_{IL2}	Low-level input voltage ¹	V_{DD} from 3.0V to 3.6V		0.8	V
V_{IH1}	High-level input voltage ¹	V_{DD} from 4.5V to 5.5V	$0.5 V_{DD}$		V
V_{IH2}	High-level input voltage ¹	V_{DD} from 3.0V to 3.6V	2.0		V
I_{IN}	Input leakage current	$V_{IN} = V_{DD}$ or V_{SS}	-1	1	μA
V_{OL1}	Low-level output voltage ³	$I_{OL} = 8ma$ $V_{DD} = 4.5V$ to $5.5V$		0.4	V
V_{OL2}	Low-level output voltage ³	$I_{OL} = 6ma$ $V_{DD} = 3.0V$ to $3.6V$		0.4	V
V_{OH1}	High-level output voltage ³	$I_{OH} = -8ma$ V_{DD} from 4.5V to 5.5V	$0.7 V_{DD}$		V
V_{OH2}	High-level output voltage ³	$I_{OH} = -6ma$ V_{DD} from 3.0V to 3.6V	2.4		V
I_{OS1}	Short-circuit output current ^{2,4}	$V_O = V_{DD}$ and V_{SS} V_{DD} from 4.5V to 5.5V	-200	200	mA
I_{OS2}	Short-circuit output current ^{2,4}	$V_O = V_{DD}$ and V_{SS} V_{DD} from 3.0V to 3.6V	-100	100	mA
I_{OL1}	Low level output current ⁹	$V_{IN} = V_{DD}$ or V_{SS} $V_{OL} = 0.4V$ V_{DD} from 4.5V to 5.5V	8		mA
I_{OL2}	Low level output current ⁹	$V_{IN} = V_{DD}$ or V_{SS} $V_{OL} = 0.4V$ V_{DD} from 3.0V to 3.6V	6		mA
I_{OH1}	High level output current ⁹	$V_{IN} = V_{DD}$ or V_{SS} $V_{OH} = V_{DD}-0.4V$ V_{DD} from 4.5V to 5.5V	-8		mA

I_{OH2}	High level output current ⁹	$V_{IN} = V_{DD}$ or V_{SS} $V_{OH} = V_{DD} - 0.4V$ V_{DD} from 3.0V to 3.6V	-6		mA
P_{total1}	Power dissipation ^{2, 8}	$C_L = 50pF$ $V_{DD} = 4.5V$ to 5.5V		1	mW/ MHz
P_{total2}	Power dissipation ^{2, 8}	$C_L = 50pF$ $V_{DD} = 3.0V$ to 3.6V		0.5	mW/ MHz
I_{DDQ}	Quiescent Supply Current	$V_{IN} = V_{DD}$ or V_{SS} V_{DD} from 3.0V to 5.5V		10	μA
ΔI_{DDQ}	Quiescent Supply Current Delta	For input under test $V_{IN} = V_{DD} - 2.1V$ For all other inputs $V_{IN} = V_{DD}$ or V_{SS} $V_{DD} = 5.5V$		1.6	mA
C_{IN}	Input capacitance ⁵	$f = 1MHz$ $V_{DD} = 0V$		15	pF
C_{OUT}	Output capacitance ⁵	$f = 1MHz$ $V_{DD} = 0V$		15	pF

Notes:

- Functional tests are conducted in accordance with MIL-STD-883 with the following input test conditions: $V_{IH} = V_{IH}(\min) + 20\%$, $- 0\%$; $V_{IL} = V_{IL}(\max) + 0\%$, $- 50\%$, as specified herein, for TTL, CMOS, or Schmitt compatible inputs. Devices may be tested using any input voltage within the above specified range, but are guaranteed to $V_{IH}(\min)$ and $V_{IL}(\max)$.
- Supplied as a design limit but not guaranteed or tested.
- Per MIL-PRF-38535, for current density $\leq 5.0E5$ amps/cm², the maximum product of load capacitance (per output buffer) times frequency should not exceed 3,765pF/MHz.
- Not more than one output may be shorted at a time for maximum duration of one second.
- Capacitance measured for initial qualification and when design changes may affect the value. Capacitance is measured between the designated terminal and V_{SS} at frequency of 1MHz and a signal amplitude of 50mV rms maximum.
- Maximum allowable relative shift equals 50mV.
- All specifications valid for the maximum radiation dose available for the respective device types.
- Power dissipation specified per switching output.
- Parameter guaranteed by design and characterization, but is not tested.

AC ELECTRICAL CHARACTERISTICS FOR THE UT54ACTS02E²

($V_{DD} = 3.0V$ to $5.5V$; $V_{SS} = 0V$ ¹, $-55^{\circ}C < T_C < +125^{\circ}C$)

SYMBOL	PARAMETER	CONDITION	V_{DD}	MINIMUM	MAXIMUM	UNIT
t_{PLH}	Input to Yn	$C_L = 50pF$	3.0V to 3.6V	1	15	ns
			4.5V to 5.5V	1	9	
t_{PHL}	Input to Yn	$C_L = 50pF$	3.0V to 3.6V	1	17	ns
			4.5V to 5.5V	1	9	

Notes:

1. Maximum allowable relative shift equals 50mV.
2. All specifications valid for the maximum radiation dose available for the respective device types.

Packaging

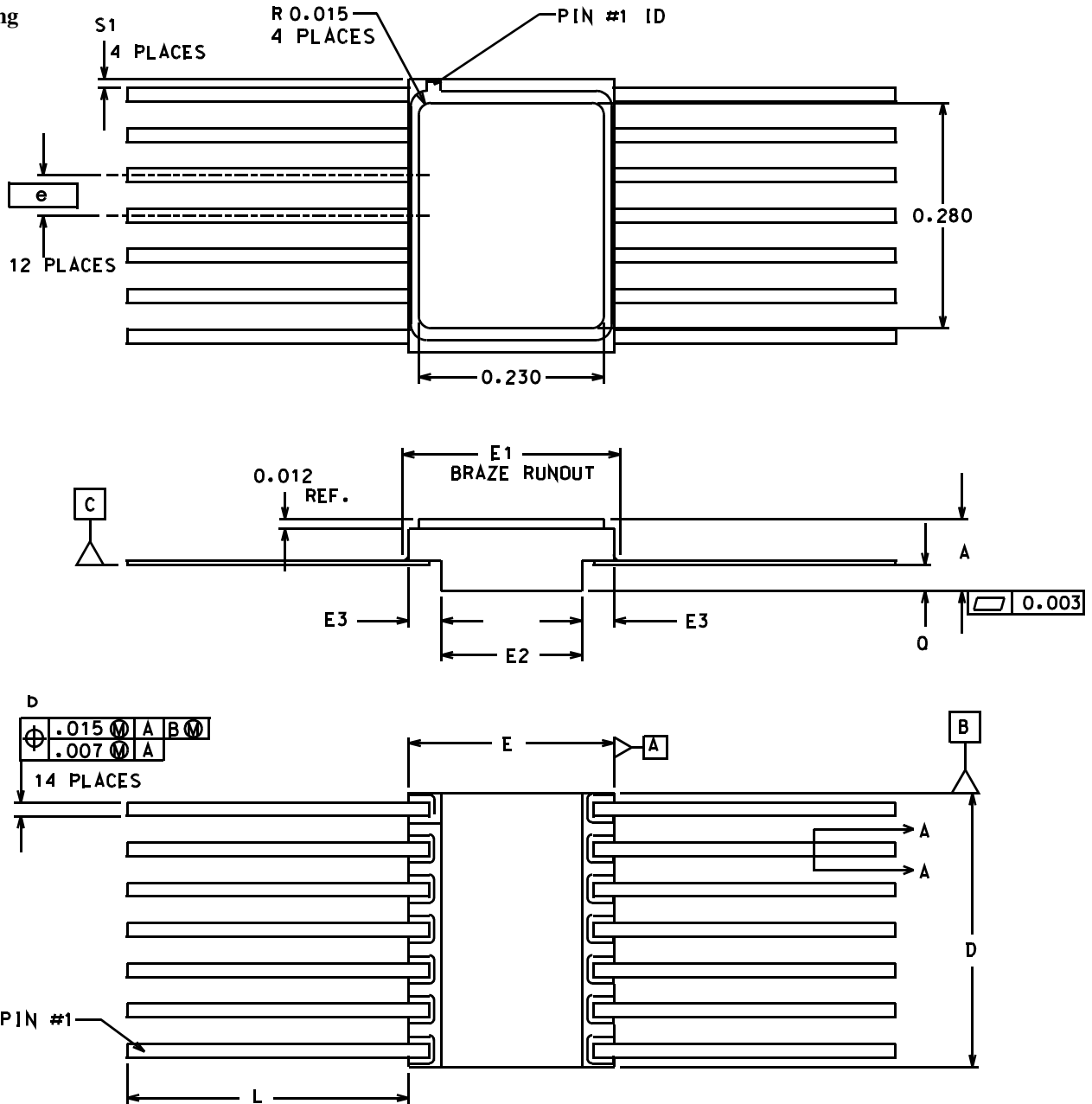

DIM	INCH		MILLIMETER	
	MIN.	MAX.	MIN.	MAX.
A	0.079	0.101	2.007	2.575
b	0.015	0.019	0.381	0.483
c	0.004	0.006	0.102	0.152
D	0.333	0.347	8.438	8.814
E	0.250	0.260	6.350	6.604
E1	-----	0.290	-----	7.366
E2	0.170	0.180	4.318	4.572
E3	0.030	-----	0.762	-----
e	0.050	BSC	1.270	BSC
L	0.340	0.360	8.636	9.144
Q	0.026	-----	0.660	-----
S1	0.005	-----	0.127	-----

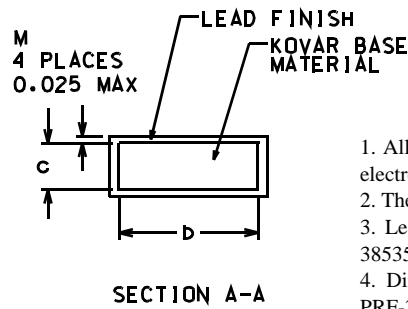

1. All exposed metallized areas are gold plated over electroplated nickel per MIL-PRF-38535.
2. The lid is electrically connected to V_{SS}.
3. Lead finishes are in accordance with MIL-PRF-38535.
4. Dimension symbol is in accordance with MIL-PRF-38533.
5. Lead position and colanarity are not measured.

Figure 1. 14-lead Flatpack

UT54ACS02E/UT54ACTS02E: SMD

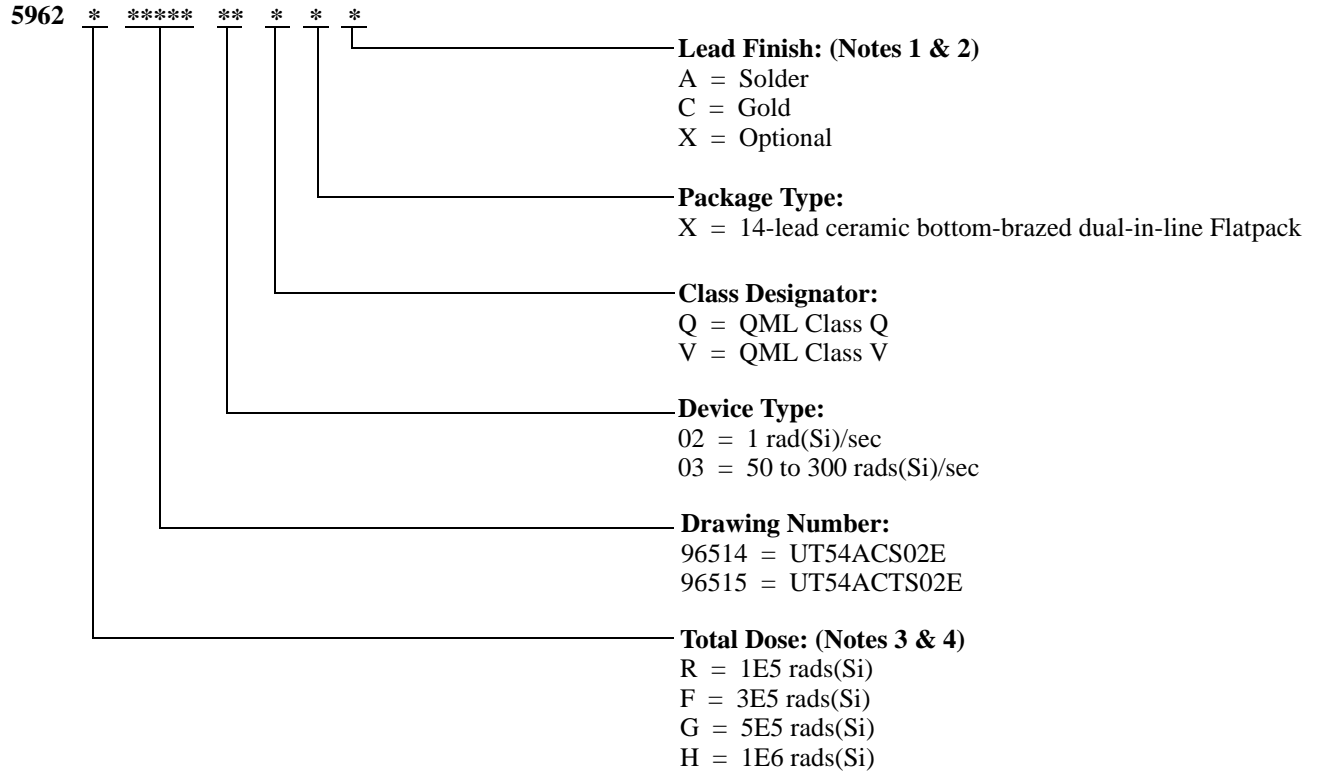

Notes:

1. Lead finish (A,C, or X) must be specified.
2. If an "X" is specified when ordering, part marking will match the lead finish and will be either "A" (solder) or "C" (gold).
3. Total dose radiation must be specified when ordering. QML Q and QML V not available without radiation hardening. For prototype inquiries, contact factory.
4. Device type 02 is only offered with a TID tolerance guarantee of 3E5 rads(Si) or 1E6 rads(Si) and is tested in accordance with MIL-STD-883 Test Method 1019 Condition A and section 3.11.2. Device type 03 is only offered with a TID tolerance guarantee of 1E5 rads(Si), 3E5 rads(Si), and 5E5 rads(Si), and is tested in accordance with MIL-STD-883 Test Method 1019 Condition A.

Aeroflex Colorado Springs - Datasheet Definition

Advanced Datasheet - Product In Development

Preliminary Datasheet - Shipping Prototype

Datasheet - Shipping QML & Reduced Hi-Rel

COLORADO

Toll Free: 800-645-8862
Fax: 719-594-8468

INTERNATIONAL

Tel: 805-778-9229
Fax: 805-778-1980

NORTHEAST

Tel: 603-888-3975
Fax: 603-888-4585

SE AND MID-ATLANTIC

Tel: 321-951-4164
Fax: 321-951-4254

WEST COAST

Tel: 949-362-2260
Fax: 949-362-2266

CENTRAL

Tel: 719-594-8017
Fax: 719-594-8468

www.aeroflex.com info-ams@aeroflex.com

Aeroflex Colorado Springs (Aeroflex) reserves the right to make changes to any products and services herein at any time without notice. Consult Aeroflex or an authorized sales representative to verify that the information in this data sheet is current before using this product. Aeroflex does not assume any responsibility or liability arising out of the application or use of any product or service described herein, except as expressly agreed to in writing by Aeroflex; nor does the purchase, lease, or use of a product or service from Aeroflex convey a license under any patent rights, copyrights, trademark rights, or any other of the intellectual rights of Aeroflex or of third parties.



Our passion for performance is defined by three attributes represented by these three icons: solution-minded, performance-driven and customer-focused