



Dual N-channel 20V, SOT-26 MOSFET 雙 N-溝道場效應管

■ **Features 特點**

Low on-resistance and maximum DC current capability 低導通電阻和最大直流電流能力

Super high density cell design 超高元胞密度設計

$R_{DS(ON)} \leq 35m\Omega @ V_{GS}=4.5V$

$R_{DS(ON)} \leq 48m\Omega @ V_{GS}=2.5V$

■ **Applications 應用**

Power Management in Note book 筆記本電源管理

Portable Equipment 便攜式設備

Battery Powered System 電池電源系統

DC/DC Converter 直流/直流變換

Load Switch 負載開關應用

■ **Internal Schematic Diagram 內部結構**

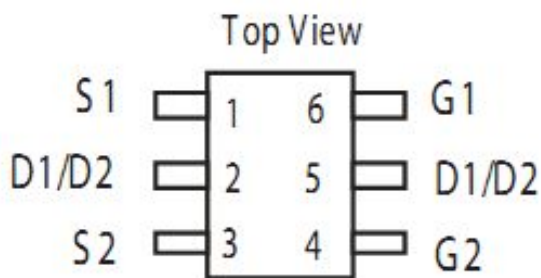
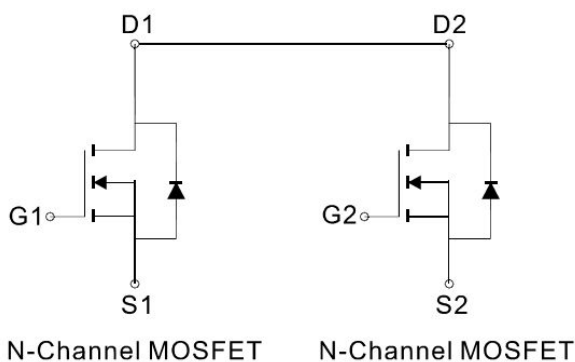

■ **Absolute Maximum Ratings 最大額定值**

Characteristic 特性參數	Symbol 符號	Max 最大值	Unit 單位
Drain-Source Voltage 漏極-源極電壓	BV_{DSS}	20	V
Gate- Source Voltage 柵極-源極電壓	V_{GS}	± 8	V
Drain Current (continuous) 漏極電流-連續	I_D	5.0	A
Drain Current (pulsed) 漏極電流-脈沖	I_{DM}	20	A
Total Device Dissipation 總耗散功率	P_{TOT}	1.25	W
Thermal Resistance Junction-Ambient 熱阻	$R_{\theta JA}$	100	$^{\circ}C/W$
Junction/Storage Temperature 結溫/儲存溫度	T_J, T_{stg}	-55~150	$^{\circ}C$



■ Electrical Characteristics 電特性

($T_A=25^{\circ}\text{C}$ unless otherwise noted 如無特殊說明，溫度為 25°C)

Characteristic 特性參數	Symbol 符號	Min 最小值	Typ 典型值	Max 最大值	Unit 單位
Drain-Source Breakdown Voltage 漏極-源極擊穿電壓($I_D=250\mu\text{A}, V_{GS}=0\text{V}$)	BV_{DSS}	20	—	—	V
Gate Threshold Voltage 柵極開啓電壓($I_D=250\mu\text{A}, V_{GS}=V_{DS}$)	$V_{GS(th)}$	0.5	—	1.0	V
Zero Gate Voltage Drain Current 零柵壓漏極電流($V_{GS}=0\text{V}, V_{DS}=20\text{V}$)	I_{DSS}	—	—	1	μA
Gate Body Leakage 柵極漏電流($V_{GS}=\pm 8\text{V}, V_{DS}=0\text{V}$)	I_{GSS}	—	—	± 100	nA
Static Drain-Source On-State Resistance 靜態漏源導通電阻($I_D=5\text{A}, V_{GS}=4.5\text{V}$) ($I_D=4\text{A}, V_{GS}=2.5\text{V}$)	$R_{DS(ON)}$	—	—	35 48	$\text{m}\Omega$
Diode Forward Voltage Drop 內附二極管正向壓降($I_{SD}=1.7\text{A}, V_{GS}=0\text{V}$)	V_{SD}	—	—	1.2	V
Input Capacitance 輸入電容 ($V_{GS}=0\text{V}, V_{DS}=10\text{V}, f=1\text{MHz}$)	C_{ISS}	—	800	—	pF
Common Source Output Capacitance 共源輸出電容($V_{GS}=0\text{V}, V_{DS}=10\text{V}, f=1\text{MHz}$)	C_{OSS}	—	155	—	pF
Reverse Transfer Capacitance 反向傳輸電容 ($V_{GS}=0\text{V}, V_{DS}=10\text{V}, f=1\text{MHz}$)	C_{RSS}	—	125	—	pF
Gate Source Charge 柵源電荷密度 ($V_{DS}=10\text{V}, I_D=3\text{A}, V_{GS}=4.5\text{V}$)	Q_{gs}	—	1.2	—	nC
Gate Drain Charge 柵漏電荷密度 ($V_{DS}=10\text{V}, I_D=3\text{A}, V_{GS}=4.5\text{V}$)	Q_{gd}	—	1.9	—	nC
Turn-On Delay Time 開啓延遲時間 ($V_{DS}=10\text{V}, I_D=1\text{A}, R_{GEN}=6\Omega, V_{GS}=4.5\text{V}$)	$t_{d(on)}$	—	8	—	ns
Turn-On Rise Time 開啓上升時間 ($V_{DS}=10\text{V}, I_D=1\text{A}, R_{GEN}=6\Omega, V_{GS}=4.5\text{V}$)	t_r	—	10	—	ns
Turn-Off Delay Time 關斷延遲時間 ($V_{DS}=10\text{V}, I_D=1\text{A}, R_{GEN}=6\Omega, V_{GS}=4.5\text{V}$)	$t_{d(off)}$	—	18	—	ns
Turn-On Fall Time 開啓下降時間 ($V_{DS}=10\text{V}, I_D=1\text{A}, R_{GEN}=6\Omega, V_{GS}=4.5\text{V}$)	t_f	—	5	—	ns



■ DIMENSION 外形封裝尺寸

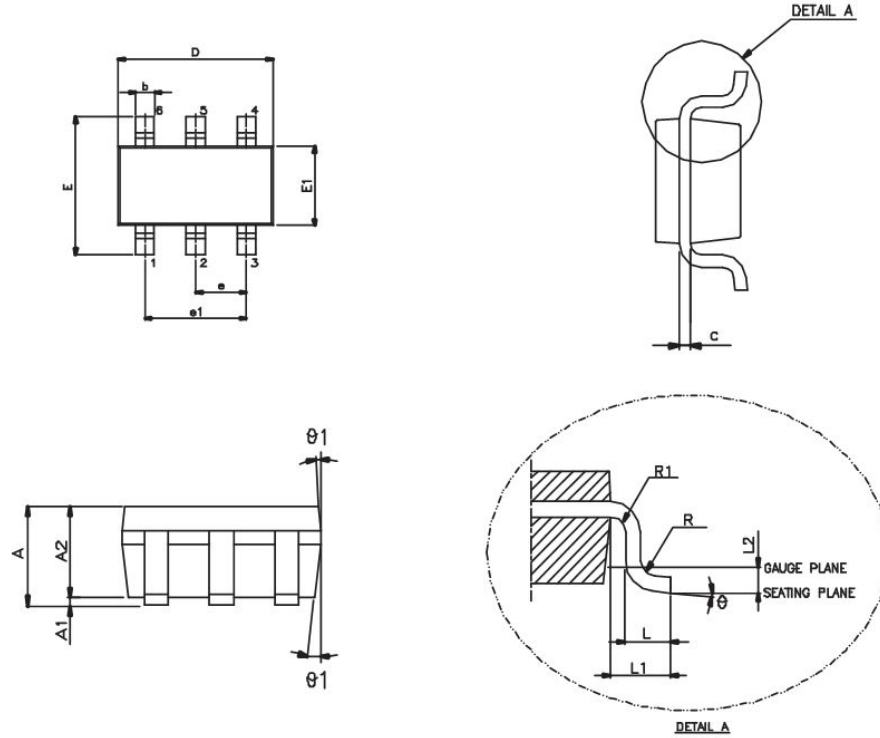

SYMBOL	MIN.	NOM.	MAX.
A	—	—	1.45
A1	—	—	0.15
A2	0.90	1.15	1.30
b	0.30	—	0.50
c	0.08	—	0.22
D	2.90 BSC.		
E	2.80 BSC.		
E1	1.60 BSC.		
e	0.95 BSC		
e1	1.90 BSC.		
L	0.30	0.45	0.60
L1	0.60 REF.		
L2	0.25 BSC.		
R	0.10	—	—
R1	0.10	—	0.25
θ	0°	4°	8°
θ_1	5°	10°	15°