

### DESCRIPTION

The HI-1579 and HI-1581 are low power CMOS dual transceivers designed to meet the requirements of the MIL-STD-1553 and MIL-STD-1760 specifications.

The transmitter section of each bus takes complementary CMOS / TTL Manchester II bi-phase data and converts it to differential voltages suitable for driving the bus isolation transformer. Separate transmitter inhibit control signals are provided for each transmitter.

The receiver section of the each bus converts the 1553 bus bi-phase data to complementary CMOS / TTL data suitable for input to a Manchester decoder. Each receiver has a separate enable input, which forces the receiver outputs to logic "0" (HI-1579) or logic 1 (HI-1581).

To minimize the package size for this function, the transmitter outputs are internally connected to the receiver inputs, so that only two pins are required for connection to each coupling transformer.

### FEATURES

- Compliant to MIL-STD-1553A and B, MIL-STD-1760 and ARINC 708A
- 3.3V single supply operation
- Smallest footprint available in 7mm x 7mm 44 pin plastic chip-scale package (QFN)
- 1.0W typical power dissipation (50% duty cycle)
- Industrial and extended temperature ranges
- Industry standard pin configurations

### PIN CONFIGURATIONS

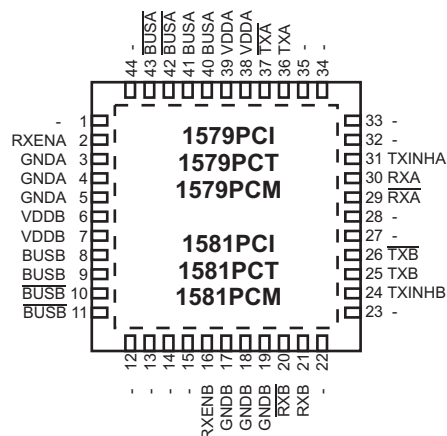

**44 Pin Plastic 7mm x 7mm  
Chip-scale package**

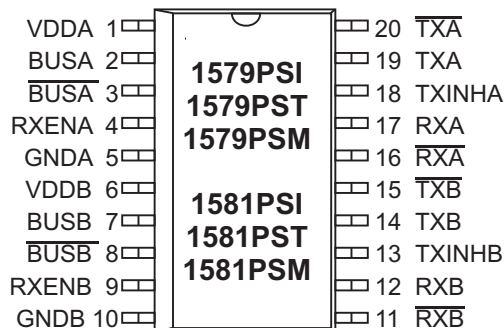

**20 Pin Plastic ESOIC - WB package**

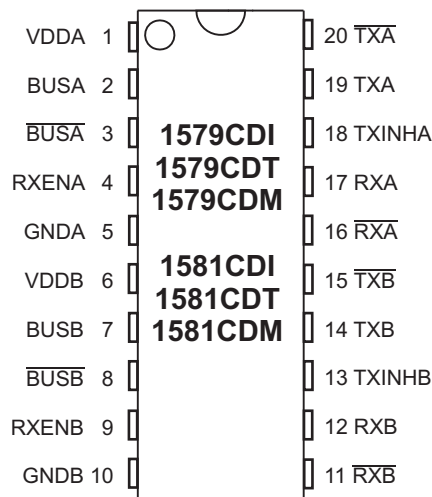

**20 Pin Ceramic DIP package**

## PIN DESCRIPTIONS

PIN (DIP & SOIC)	SYMBOL	FUNCTION	DESCRIPTION
1	VDDA	power supply	+3.3 volt power for transceiver A
2	BUSA	analog output	MIL-STD-1533 bus driver A, positive signal
3	$\overline{BUSA}$	analog output	MIL-STD-1553 bus driver A, negative signal
4	RXENA	digital input	Receiver A enable. If low, forces RXA and $\overline{RXA}$ low
5	GNDA	power supply	Ground for transceiver A
6	VDDDB	power supply	+3.3 volt power for transceiver B
7	BUSB	analog output	MIL-STD-1533 bus driver B, positive signal
8	$\overline{BUSB}$	analog output	MIL-STD-1553 bus driver B, negative signal
9	RXENB	digital input	Receiver B enable. If low, forces RXB and $\overline{RXB}$ low
10	GNDB	power supply	Ground for transceiver B
11	$\overline{RXB}$	digital output	Receiver B output, inverted
12	RXB	digital output	Receiver B output, non-inverted
13	TXINHB	digital input	Transmit inhibit, bus B. If high BUSB, $\overline{BUSB}$ disabled
14	TXB	digital input	Transmitter B digital data input, non-inverted
15	$\overline{TXB}$	digital input	Transmitter B digital data input, inverted
16	$\overline{RXA}$	digital output	Receiver A output, inverted
17	RXA	digital output	Receiver A output, non-inverted
18	TXINHA	digital input	Transmit inhibit, bus A. If high BUSA, $\overline{BUSA}$ disabled
19	TXA	digital input	Transmitter A digital data input, non-inverted
20	$\overline{TXA}$	digital input	Transmitter A digital data input, inverted

## FUNCTIONAL DESCRIPTION

The HI-1579 family of dual data bus transceivers contains differential voltage source drivers and differential receivers. It is intended for applications using a MIL-STD-1553 A/B data bus. The device produces a trapezoidal output waveform during transmission.

### TRANSMITTER

Data input to the device's transmitter section is from the complementary CMOS inputs TXA/B and  $\overline{TXA/B}$ . The transmitter accepts Manchester II bi-phase data and converts it to differential voltages on BUSA/B and  $\overline{BUSA/B}$ . The transceiver outputs are either direct- or transformer-coupled to the MIL-STD-1553 data bus. Both coupling methods produce a nominal voltage on the bus of 7.5 volts peak to peak.

The transmitter is automatically inhibited and placed in the high impedance state when both TXA/B and  $\overline{TXA/B}$  are driven with the same logic state. A logic "1" applied to the TXINHA/B input forces the transmitter to the high impedance state, regardless of the state of TXA/B and  $\overline{TXA/B}$ .

### RECEIVER

The receiver accepts bi-phase differential data from the MIL-STD-1553 bus through the same direct- or transformer-coupled interface as the transmitter. The receiver's differential input stage drives a filter and threshold

comparator to produce CMOS data at the RXA/B and  $\overline{RXA/B}$  output pins. When the MIL-STD-1553 bus is idle and RXENA or RXENB are high, RXA/B will be logic "0" on HI-1579 and logic "1" on HI-1581.

The receiver outputs are forced to the bus idle state (logic "0" for HI-1579 or logic "1" for HI-1581) when the RXENA or RXENB is low.

### MIL-STD-1553 BUS INTERFACE

A direct-coupled interface (see Figure 2) uses a 1:2.5 ratio isolation transformer and two 55 ohm isolation resistors between the transformer and the bus. The primary center-tap of the isolation transformer must be connected to GND.

In a transformer-coupled interface (see Figure 2), the transceiver is also connected to a 1:2.5 isolation transformer which in turn is connected to a 1:1.4 coupling transformer. The transformer coupled method also requires two coupling resistors equal to 75% of the bus characteristic impedance ( $Z_0$ ) between the coupling transformer and the bus.

Figure 3 and Figure 4 show test circuits for measuring electrical characteristics of both direct- and transformer-coupled interfaces respectively. (See electrical characteristics on the following pages).

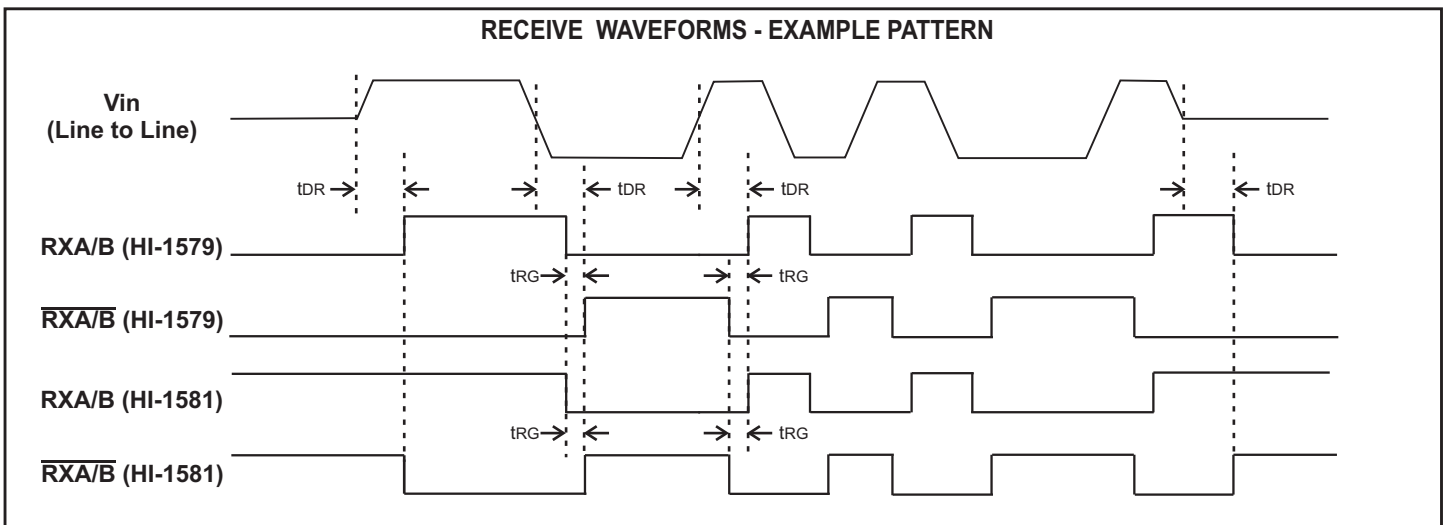
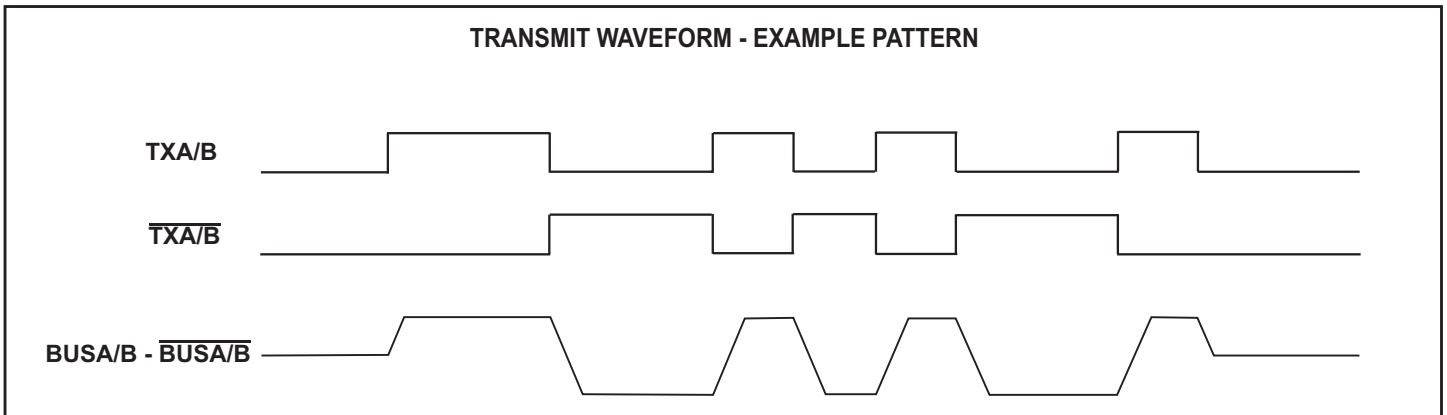
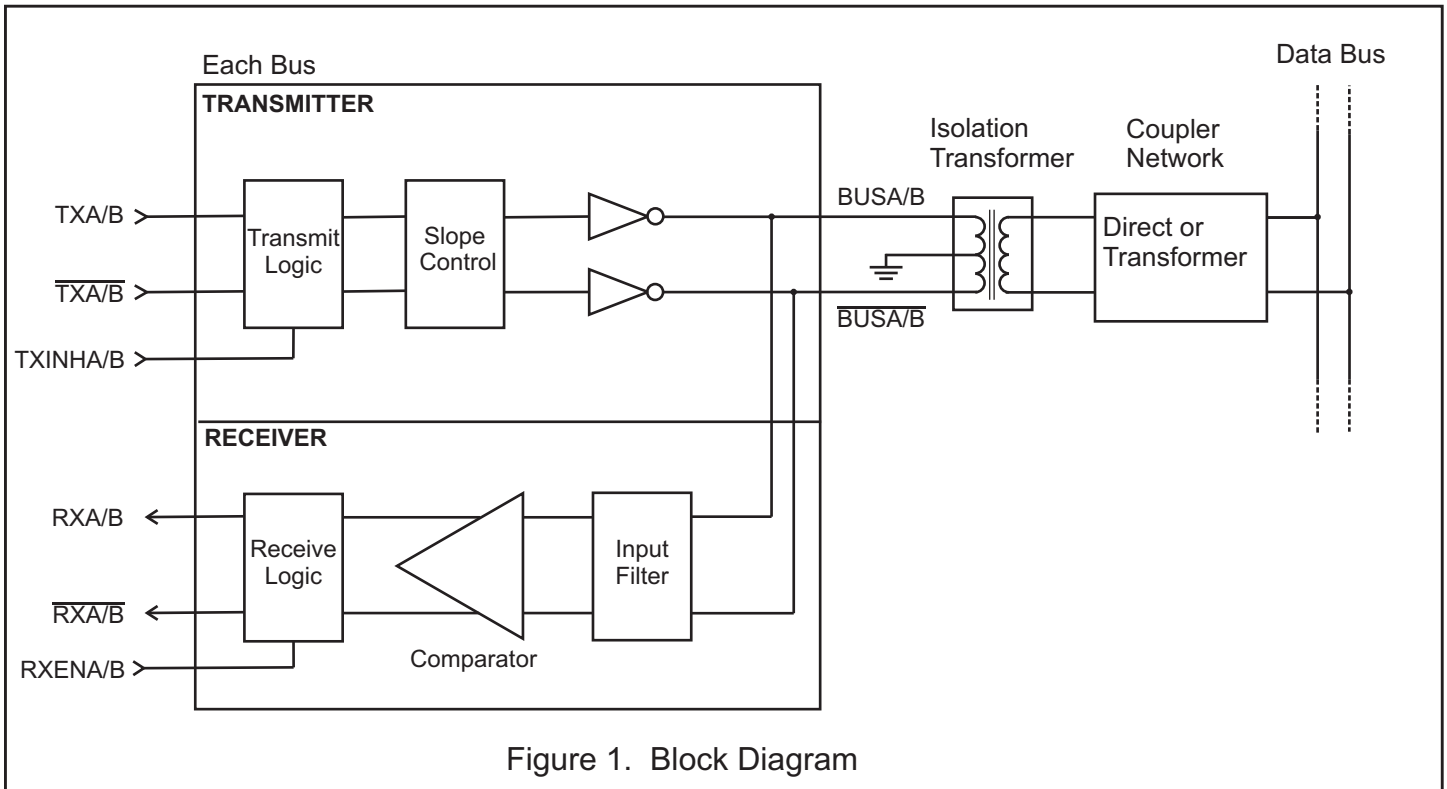

**ABSOLUTE MAXIMUM RATINGS**

Supply voltage (VDD)	-0.3 V to +5 V
Logic input voltage range	-0.3 V dc to +3.6 V
Receiver differential voltage	50 Vp-p
Driver peak output current	+1.0 A
Power dissipation at 25°C ceramic DIL, derate	1.0 W 7mW/°C
Solder Temperature	275°C for 10 sec.
Junction Temperature	175°C
Storage Temperature	-65°C to +150°C

**RECOMMENDED OPERATING CONDITIONS**

Supply Voltage	VDD..... 3.3V... ±5%
Temperature Range	Industrial ..... -40°C to +85°C Hi-Temp ..... -55°C to +125°C

*NOTE: Stresses above absolute maximum ratings or outside recommended operating conditions may cause permanent damage to the device. These are stress ratings only. Operation at the limits is not recommended.*

**DC ELECTRICAL CHARACTERISTICS**

VDD = 3.3 V, GND = 0V, TA = Operating Temperature Range (unless otherwise specified).

PARAMETER	SYMBOL	CONDITION	MIN	TYP	MAX	UNITS
Operating Voltage	VDD		3.15	3.30	3.45	V
Total Supply Current	Icc1	Not Transmitting		4	17	mA
	Icc2	Transmit one bus @ 50% duty cycle		225	320	mA
	Icc3	Transmit one bus @ 100% duty cycle		425	640	mA
Power Dissipation	PD1	Not Transmitting			0.06	W
	PD2	Transmit one bus @ 100% duty cycle		0.5	1.0	W
Min. Input Voltage (HI)	VIH	Digital inputs	70%			VDD
Max. Input Voltage (LO)	VIL	Digital inputs			30%	VDD
Min. Input Current (HI)	IiH	Digital inputs			20	µA
Max. Input Current (LO)	IiL	Digital inputs	-20			µA
Min. Output Voltage (HI)	VoH	Iout = -1.0mA, Digital outputs	90%			VDD
Max. Output Voltage (LO)	VIH	Iout = 1.0mA, Digital outputs			10%	VDD
<b>RECEIVER (Measured at Point "Ad" in Figure 2 unless otherwise specified)</b>						
Input resistance	RIN	Differential (at chip pins)	2			Kohm
Input capacitance	CIN	Differential			5	pF
Common mode rejection ratio	CMRR		40			dB
Input Level	VIN	Differential			9	Vp-p
Input common mode voltage	VICM		-10.0		10.0	V-pk
Threshold Voltage - Direct-coupled Detect	VTHD	1 MHz Sine Wave Measured at Point "Ad" in Figure 2 RXA/B, $\overline{RXA/B}$ pulse width >70 ns	1.15			Vp-p
	VTHND	No pulse at RXA/B, $\overline{RXA/B}$			0.28	Vp-p
Threshold Voltage - Transformer-coupled Detect	VTHD	1 MHz Sine Wave Measured at Point "Ar" in Figure 3 RXA/B, $\overline{RXA/B}$ pulse width >70 ns	0.86			Vp-p
	VTHND	No pulse at RXA/B, $\overline{RXA/B}$			0.20	Vp-p

## DC ELECTRICAL CHARACTERISTICS (cont.)

V<sub>DD</sub> = 3.3 V, GND = 0V, T<sub>A</sub> = Operating Temperature Range (unless otherwise specified).

PARAMETER	SYMBOL	CONDITION	MIN	TYP	MAX	UNITS
<b>TRANSMITTER (Measured at Point "Ad" in Figure 2 unless otherwise specified)</b>						
Output Voltage	Direct coupled	V <sub>OUT</sub>	35 ohm load (Measured at Point "Ad" in Figure 2)	6.1	9.0	Vp-p
	Transformer coupled	V <sub>OUT</sub>	70 ohm load (Measured at Point "At" in Figure 3)	20.0	27.0	Vp-p
Output Noise		V <sub>ON</sub>	Differential, inhibited		10.0	mVp-p
Output Dynamic Offset Voltage	Direct coupled	V <sub>DYN</sub>	35 ohm load (Measured at Point "Ad" in Figure 2)	-90	90	mV
	Transformer coupled	V <sub>DYN</sub>	70 ohm load (Measured at Point "At" in Figure 3)	-250	250	mV
Output Capacitance		C <sub>OUT</sub>	1 MHz sine wave		15	pF

## AC ELECTRICAL CHARACTERISTICS

V<sub>DD</sub> = 3.3 V, GND = 0V, T<sub>A</sub> = Operating Temperature Range (unless otherwise specified).

PARAMETER	SYMBOL	TEST CONDITIONS	MIN	TYP	MAX	UNITS
<b>RECEIVER (Measured at Point "Ad" in Figure 2 unless otherwise specified)</b>						
Receiver Delay	t <sub>DR</sub>	From input zero crossing to RXA/B or $\overline{RXA/B}$			450	ns
Receiver gap time	t <sub>RG</sub>	Spacing between RXA/B and $\overline{RXA/B}$ pulses. 1 MHz sine wave applied at point "At" Figure 3, amplitude range 0.86 Vp-p to 27.0Vp-p	90		365	ns
Receiver Enable Delay	t <sub>REN</sub>	From STROBE rising or falling edge to RXA/B or $\overline{RXA/B}$			40	ns
<b>TRANSMITTER (Measured at Point "Ad" in Figure 2)</b>						
Driver Delay	t <sub>DT</sub>	TXA/B, TXA/B to BUSA/B, BUSA/B			150	ns
Rise time	t <sub>r</sub>	35 ohm load	100		300	ns
Fall Time	t <sub>f</sub>	35 ohm load	100		300	ns
Inhibit Delay	t <sub>DI-H</sub>	Inhibited output			100	ns
	t <sub>DI-L</sub>	Active output			150	ns

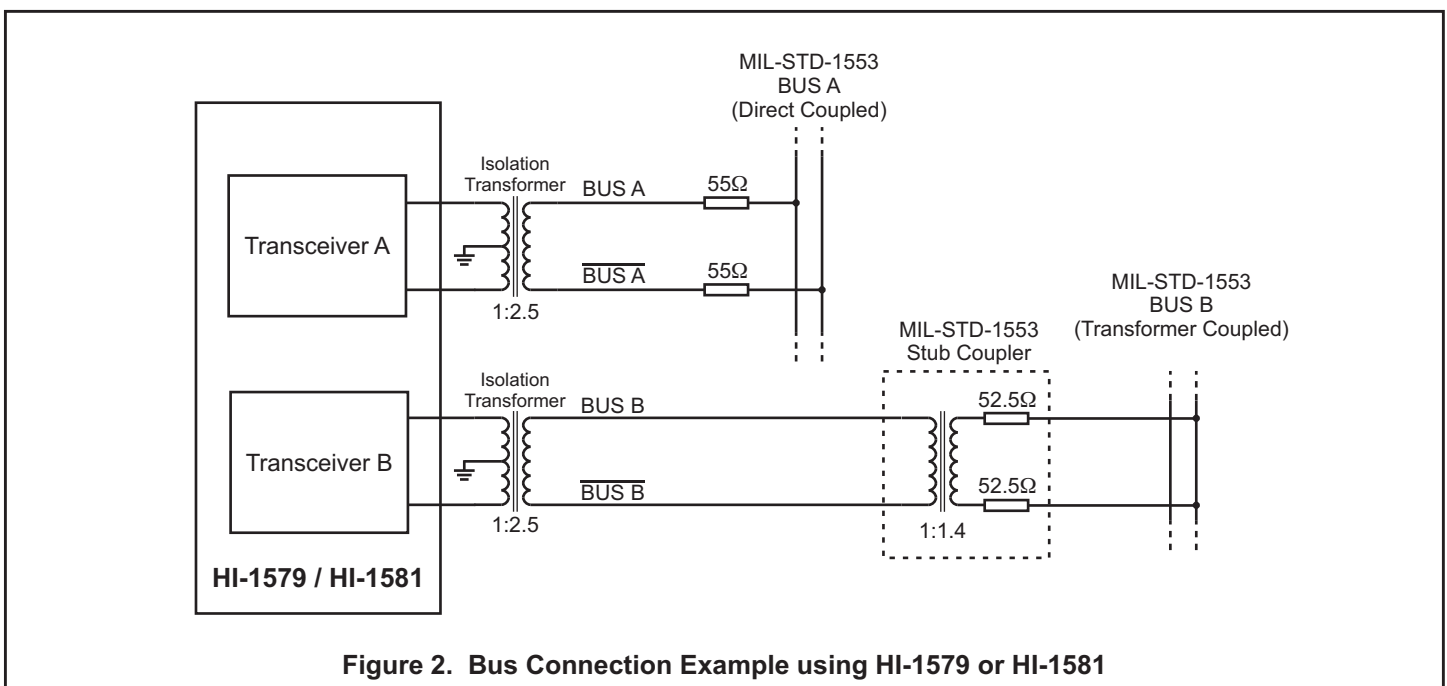

Figure 2. Bus Connection Example using HI-1579 or HI-1581

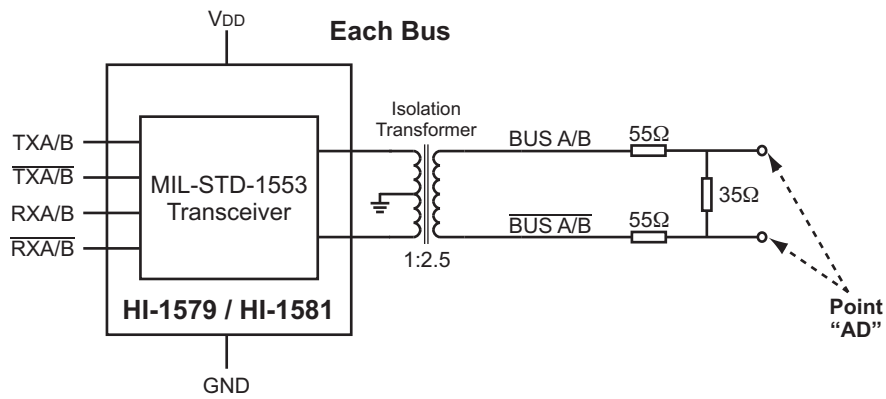

Figure 3. Direct Coupled Test Circuit

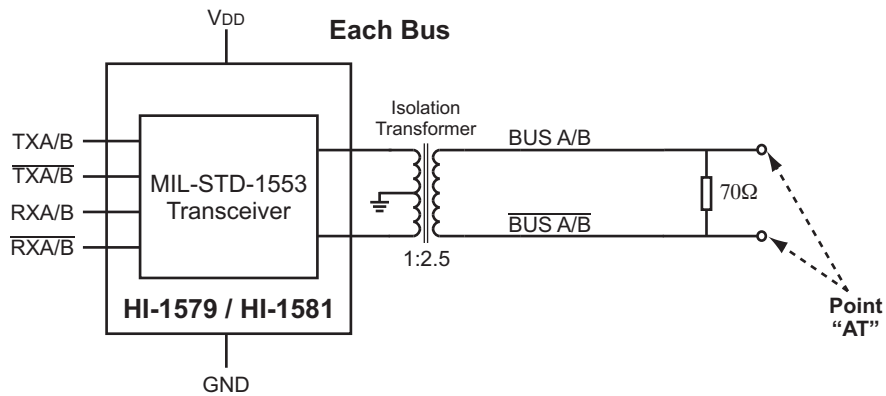

Figure 4. Transformer Coupled Test Circuit

## HEAT SINK ESOIC & CHIP-SCALE PACKAGES

The HI-1579PSI/T/M and HI-1581PSI/T/M use a 20-pin thermally enhanced SOIC package. The HI-1579PCI/T/M and HI-1581PCI/T/M use a plastic chip-scale package (QFN). These packages include a metal heat sink located on the bottom surface of the device. This heat sink may be soldered down to the printed circuit board for optimum thermal dissipation. The heat sink is electrically isolated

and may be soldered to any convenient power or ground plane.

## APPLICATIONS NOTE

Holt Applications Note AN-500 provides circuit design notes regarding the use of Holt's family of MIL-STD-1553 transceivers. Layout considerations, as well as recommended interface and protection components are included.

## THERMAL CHARACTERISTICS

PART NUMBER	PACKAGE STYLE	CONDITION	$\theta_{JA}$	JUNCTION TEMPERATURE		
				$T_A=25^\circ\text{C}$	$T_A=85^\circ\text{C}$	$T_A=125^\circ\text{C}$
HI-1579PSI / T / M	20-pin Thermally enhanced plastic SOIC ( ESOIC)	Heat sink unsoldered	54°C/W	68°C	130°C	170°C
HI-1581PSI / T / M		Heat sink soldered	47°C/W	63°C	124°C	165°C
HI-1579CDI / T / M HI-1579CDI / T / M	20-pin Ceramic side-brazed	Socketed	62°C/W	74°C	136°C	175°C
HI-1579PCI / T / M HI-1581PCI / T / M	44-Plastic chip-scale package (QFN)	Heat sink unsoldered	49°C/W	65°C	126°C	166°C

Data taken at VDD=3.3V, continuous transmission at 1Mbit/s, single transmitter enabled.

**ORDERING INFORMATION**

**HI - 15xx xx x x (Plastic)**

PART NUMBER	LEAD FINISH
Blank	Tin / Lead (Sn / Pb) Solder
F	100% Matte Tin (Pb-free RoHS compliant)

PART NUMBER	TEMPERATURE RANGE	FLOW	BURN IN
I	-40°C TO +85°C	I	No
T	-55°C TO +125°C	T	No
M	-55°C TO +125°C	M	Yes

PART NUMBER	PACKAGE DESCRIPTION
PC	44 PIN PLASTIC CHIP-SCALE PACKAGE QFN (44PCS)
PS	20 PIN PLASTIC ESOIC, Thermally Enhanced Wide SOIC w/Heat Sink (20HWE)

PART NUMBER	RXENA = 0		RXENB = 0	
	RXA	$\overline{RxA}$	RXB	$\overline{RxB}$
1579	0	0	0	0
1581	1	1	1	1

**HI - 15xxCD x (Ceramic)**

PART NUMBER	TEMPERATURE RANGE	FLOW	BURN IN	LEAD FINISH
I	-40°C TO +85°C	I	No	Gold (Pb-free, RoHS compliant)
T	-55°C TO +125°C	T	No	Gold (Pb-free, RoHS compliant)
M	-55°C TO +125°C	M	Yes	Tin / Lead (Sn / Pb) Solder

PART NUMBER	RXENA = 0		RXENB = 0		PACKAGE DESCRIPTION
	RXA	$\overline{RxA}$	RXB	$\overline{RxB}$	
1579	0	0	0	0	20 PIN CERAMIC SIDE BRAZED DIP (20C)
1581	1	1	1	1	20 PIN CERAMIC SIDE BRAZED DIP (20C)

**RECOMMENDED TRANSFORMERS**

The HI-1579 and HI-1581 transceivers have been characterized for compliance with the electrical requirements of MIL-STD-1553 when used with the following

transformers. Holt recommends Premier Magnetics parts as offering the best combination of electrical performance, low cost and small footprint.

MANUFACTURER	PART NUMBER	APPLICATION	TURNS RATIO	DIMENSIONS
Premier Magnetics	PM-DB2791S	Isolation	Single 1:2.5	.400 x .400 x .185 inches
Premier Magnetics	PM-DB2756	Isolation	Dual 1:2.5	.930 x .575 x .185 inches
Premier Magnetics	PM-DB2702	Stub coupling	1:1.4	.625 x .500 x .250 inches

## REVISION HISTORY

Document	Rev.	Date	Description of Change
DS1579	F	07/24/09	Correct typographical errors in package dimensions. Clarified available temperature ranges.
	G	10/5/09	Clarified status of RXA/B and $\overline{RXA/B}$ pins in bus idle state when RXENA or RXENB are high (logic "1"). Clarified nomenclature of chip-scale package as QFN. Added 'M' flow option for QFN package ('PCM' package option). Updated datasheet to include HI-1581 variant.
	H	01/26/10	Corrected dynamic current and power dissipation values.
	I	02/01/10	Revised Thermal Characteristic table to correspond to correct dynamic currents and power dissipation values.
	J	08/18/10	Revised DC Electrical Characteristics table to correspond to actual measured values. Revised Bus Connection and Test Circuit Diagrams. Revised SOIC package standoff dimension.
	K	05/23/13	Revised text in functional description to improve clarity. Added more detail to AC timing parameter table. Removed reference to non-preferred transformers Updated package drawings..



**20-PIN PLASTIC SMALL OUTLINE (ESQIC) - WB**  
(Wide Body, Thermally Enhanced)

*inches (millimeters)*  
Package Type: 20HWE

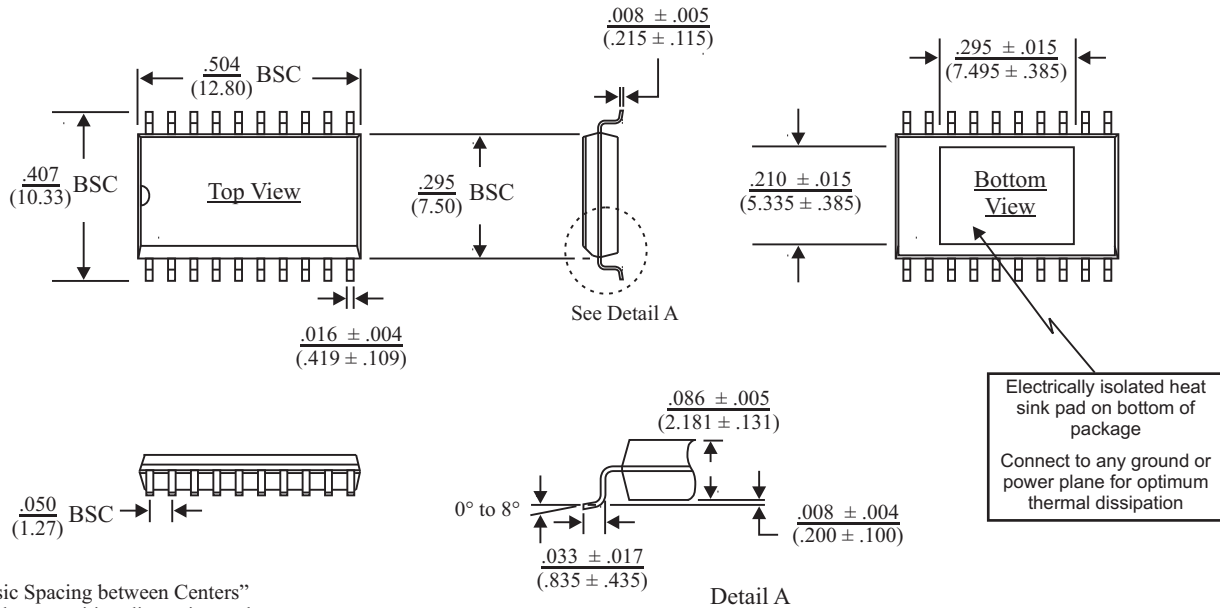

BSC = "Basic Spacing between Centers" is theoretical true position dimension and has no tolerance. (JEDEC Standard 95)

**20-PIN CERAMIC SIDE-BRAZED DIP**

*inches (millimeters)*  
Package Type: 20C

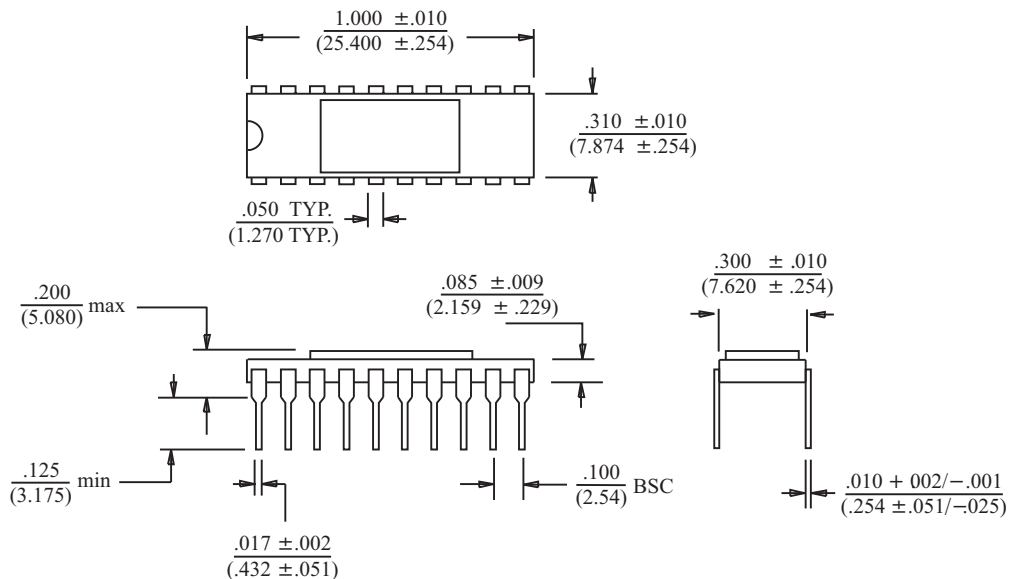

BSC = "Basic Spacing between Centers" is theoretical true position dimension and has no tolerance. (JEDEC Standard 95)

**44-PIN PLASTIC CHIP-SCALE PACKAGE (QFN)**

*inches (millimeters)*

Package Type: 44PCS

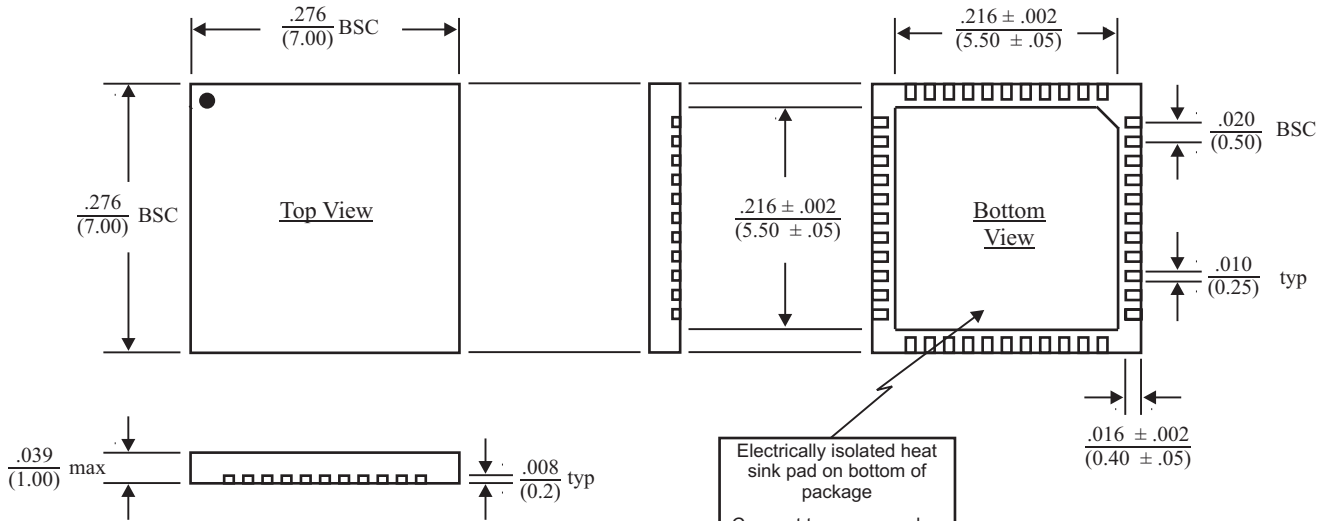

Electrically isolated heat sink pad on bottom of package  
Connect to any ground or power plane for optimum thermal dissipation

BSC = "Basic Spacing between Centers" is theoretical true position dimension and has no tolerance. (JEDEC Standard 95)