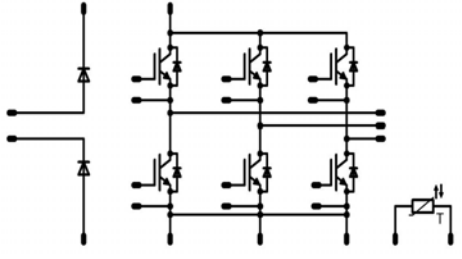

flowPACK 1	600V/50A
<div style="border: 1px solid black; padding: 5px; margin-bottom: 5px;"> <p style="text-align: center; background-color: #000080; color: white; margin: 0;"><b>Features</b></p> <ul style="list-style-type: none"> <li>Inverter, blocking diodes</li> <li>Very compact housing, easy to route</li> <li>IGBT3 technology</li> </ul> </div> <div style="border: 1px solid black; padding: 5px; margin-bottom: 5px;"> <p style="text-align: center; background-color: #000080; color: white; margin: 0;"><b>Target Applications</b></p> <ul style="list-style-type: none"> <li>Power Regeneration</li> </ul> </div> <div style="border: 1px solid black; padding: 5px;"> <p style="text-align: center; background-color: #000080; color: white; margin: 0;"><b>Types</b></p> <ul style="list-style-type: none"> <li>10-F106R6A050SB-M435E08</li> <li>10-F106R6A050SB01-M435E18</li> </ul> </div>	<div style="border: 1px solid black; padding: 5px; margin-bottom: 5px;"> <p style="text-align: center; background-color: #000080; color: white; margin: 0;"><b>flow1 housing</b></p>  </div> <div style="border: 1px solid black; padding: 5px;"> <p style="text-align: center; background-color: #000080; color: white; margin: 0;"><b>Schematic</b></p>  </div>

## Maximum Ratings

$T_j=25^{\circ}\text{C}$ , unless otherwise specified

Parameter	Symbol	Condition	Value	Unit
<b>Blocking Diode</b>				
Repetitive peak reverse voltage	$V_{RRM}$		1600	V
DC forward current	$I_{FAV}$	$T_j=T_{jmax}$ $T_h=80^{\circ}\text{C}$	75	A
Surge forward current	$I_{FSM}$	$t_p=10\text{ms}$ $T_j=25^{\circ}\text{C}$	1000	A
I2t-value	$I^2t$		5000	$\text{A}^2\text{s}$
Power dissipation per Diode	$P_{tot}$	$T_j=T_{jmax}$ $T_h=80^{\circ}\text{C}$	123	W
Maximum Junction Temperature	$T_{jmax}$		150	$^{\circ}\text{C}$
<b>Inverter Transistor</b>				
Collector-emitter break down voltage	$V_{CE}$		600	V
DC collector current	$I_C$	$T_j=T_{jmax}$ $T_h=80^{\circ}\text{C}$	38	A
Repetitive peak collector current	$I_{Cpulse}$	$t_p$ limited by $T_{jmax}$	150	A
Turn off safe operating area		$V_{CE} \leq 600\text{V}$ , $T_j \leq T_{op max}$	150	A
Power dissipation per IGBT	$P_{tot}$	$T_j=T_{jmax}$ $T_h=80^{\circ}\text{C}$	70	W
Gate-emitter peak voltage	$V_{GE}$		$\pm 20$	V
Short circuit ratings	$t_{SC}$ $V_{CC}$	$T_j \leq 150^{\circ}\text{C}$ $V_{GE}=15\text{V}$	6 360	$\mu\text{s}$ V
Maximum Junction Temperature	$T_{jmax}$		175	$^{\circ}\text{C}$

## Maximum Ratings

 $T_j=25^{\circ}\text{C}$ , unless otherwise specified

Parameter	Symbol	Condition	Value	Unit
-----------	--------	-----------	-------	------

### Inverter Diode

Peak Repetitive Reverse Voltage	$V_{RRM}$	$T_j=25^{\circ}\text{C}$	600	V
DC forward current	$I_F$	$T_j=T_{jmax}$ $T_h=80^{\circ}\text{C}$	27	A
Repetitive peak forward current	$I_{FRM}$	$t_p$ limited by $T_{jmax}$	60	A
Power dissipation per Diode	$P_{tot}$	$T_j=T_{jmax}$ $T_h=80^{\circ}\text{C}$	46	W
Maximum Junction Temperature	$T_{jmax}$		175	$^{\circ}\text{C}$

### Thermal Properties

Storage temperature	$T_{stg}$		-40...+125	$^{\circ}\text{C}$
Operation temperature under switching condition	$T_{op}$		-40...+( $T_{jmax} - 25$ )	$^{\circ}\text{C}$

### Insulation Properties

Insulation voltage	$V_{is}$	$t=2\text{s}$ DC voltage	4000	V
Creepage distance			min 12.7	mm
Clearance			min 12.7	mm
Comparative tracking index	CTI		>200	

**Characteristic Values**

Parameter	Symbol	Conditions					Value			Unit	
		$V_{GE}[V]$ or $V_{GS}[V]$	$V_r[V]$ or $V_{CE}[V]$ or $V_{DS}[V]$	$I_c[A]$ or $I_F[A]$ or $I_D[A]$	$T_j$	Min	Typ	Max			
<b>Blocking Diode</b>											
Forward voltage	$V_F$				75	$T_j=25^\circ C$ $T_j=125^\circ C$		1.19 1.16	1.21	V	
Threshold voltage (for power loss calc. only)	$V_{to}$				75	$T_j=25^\circ C$ $T_j=125^\circ C$		0.9 0.79		V	
Slope resistance (for power loss calc. only)	$r_t$				75	$T_j=25^\circ C$ $T_j=125^\circ C$		3 4		m $\Omega$	
Reverse current	$I_r$			1600		$T_j=25^\circ C$ $T_j=125^\circ C$			0.05 1.1	mA	
Thermal resistance chip to heatsink per chip	$R_{thJH}$	Thermal grease thickness $\leq$ 50um						0.57		K/W	
Thermal resistance chip to heatsink per chip	$R_{thJC}$	$\lambda = 1$ W/mK						0.38			
<b>Inverter Transistor</b>											
Gate emitter threshold voltage	$V_{GE(th)}$	$V_{CE}=V_{GE}$			0.0008	$T_j=25^\circ C$ $T_j=150^\circ C$		5	5.8	6.5	V
Collector-emitter saturation voltage	$V_{CE(sat)}$		15		50	$T_j=25^\circ C$ $T_j=150^\circ C$	1.05	1.76 2.06	2.1	V	
Collector-emitter cut-off current incl. Diode	$I_{CES}$		0	600		$T_j=25^\circ C$ $T_j=150^\circ C$			0.35	mA	
Gate-emitter leakage current	$I_{GES}$		20	0		$T_j=25^\circ C$ $T_j=150^\circ C$			650	nA	
Integrated Gate resistor	$R_{gint}$							none		$\Omega$	
Turn-on delay time	$t_{d(on)}$	$R_{gon}=8 \Omega$ $R_{gon}=8 \Omega$	$\pm 15$	300	50	$T_j=25^\circ C$ $T_j=150^\circ C$		171		ns	
Rise time	$t_r$					$T_j=25^\circ C$ $T_j=150^\circ C$		27			
Turn-off delay time	$t_{d(off)}$					$T_j=25^\circ C$ $T_j=150^\circ C$		228			
Fall time	$t_f$					$T_j=25^\circ C$ $T_j=150^\circ C$		100			
Turn-on energy loss per pulse	$E_{on}$					$T_j=25^\circ C$ $T_j=150^\circ C$		1.60			
Turn-off energy loss per pulse	$E_{off}$	$T_j=25^\circ C$ $T_j=150^\circ C$		1.56		mWs					
Input capacitance	$C_{ies}$							3140		pF	
Output capacitance	$C_{oss}$	$f=1$ MHz	0	25		$T_j=25^\circ C$		200			
Reverse transfer capacitance	$C_{riss}$							93			
Gate charge	$Q_{Gate}$		$\pm 15$			$T_j=25^\circ C$		310		nC	
Thermal resistance chip to heatsink per chip	$R_{thJH}$	Thermal grease thickness $\leq$ 50um						1.36		K/W	
Thermal resistance chip to case per chip	$R_{thJC}$	$\lambda = 1$ W/mK						0.90			
<b>Inverter Diode</b>											
Diode forward voltage	$V_F$				30	$T_j=25^\circ C$ $T_j=150^\circ C$	1.25	1.75 1.7	2.15	V	
Peak reverse recovery current	$I_{RRM}$	$R_{gon}=8 \Omega$	$\pm 15$	300	30	$T_j=25^\circ C$ $T_j=150^\circ C$		34.29		A	
Reverse recovery time	$t_{rr}$					$T_j=25^\circ C$ $T_j=150^\circ C$		183.2		ns	
Reverse recovered charge	$Q_{rr}$					$T_j=25^\circ C$ $T_j=150^\circ C$		2.16		$\mu C$	
Peak rate of fall of recovery current	$di(rec)max/dt$					$T_j=25^\circ C$ $T_j=150^\circ C$		tbd.		A/ $\mu s$	
Reverse recovered energy	$E_{rec}$					$T_j=25^\circ C$ $T_j=150^\circ C$		1.24		mWs	
Thermal resistance chip to heatsink per chip	$R_{thJH}$	Thermal grease thickness $\leq$ 50um						2.07		K/W	
Thermal resistance chip to case per chip	$R_{thJC}$	$\lambda = 1$ W/mK						1.24			

**Characteristic Values**

Parameter	Symbol	Conditions					Value			Unit
		$V_{GE}[V]$ or $V_{GS}[V]$	$V_r[V]$ or $V_{CE}[V]$ or $V_{DS}[V]$	$I_c[A]$ or $I_F[A]$ or $I_D[A]$	$T_j$	Min	Typ	Max		
<b>Thermistor</b>										
Rated resistance	R					T=25°C		22000		Ω
Deviation of R100	$\Delta R/R$	R100=1486 Ω				T=100°C	-5		5	%
Power dissipation	P					T=25°C		200		mW
Power dissipation constant						T=25°C		2		mW/K
B-value	$B_{(25/50)}$	Tol. ±3%				T=25°C		3950		K
B-value	$B_{(25/100)}$	Tol. ±3%				T=25°C		3996		K
Vincotech NTC Reference									B	
<b>Module Properties</b>										
Thermal resistance, case to heatsink	$R_{thCH}$							tbd.		K/W
Module stray inductance	$L_{sCE}$							5		nH
Chip module lead resistance, terminals -chip	$R_{cc'1+EE'}$							tbd.		mΩ
Mounting torque	M						3.8	4	4.2	Nm
Terminal connection torque	M						6.7	7	7.4	Nm
Weight	G							tbd.		g

### Ordering Code and Marking - Outline - Pinout

#### Ordering Code & Marking

Version	Ordering Code	in DataMatrix as	in packaging barcode as
12mm housing	10-F106R6A050SB-M435E08	M435-E08	M435-E08
12mm housing, without thermistor	10-F106R6A050SB01-M435E18	M435-E18	M435-E18

#### Outline

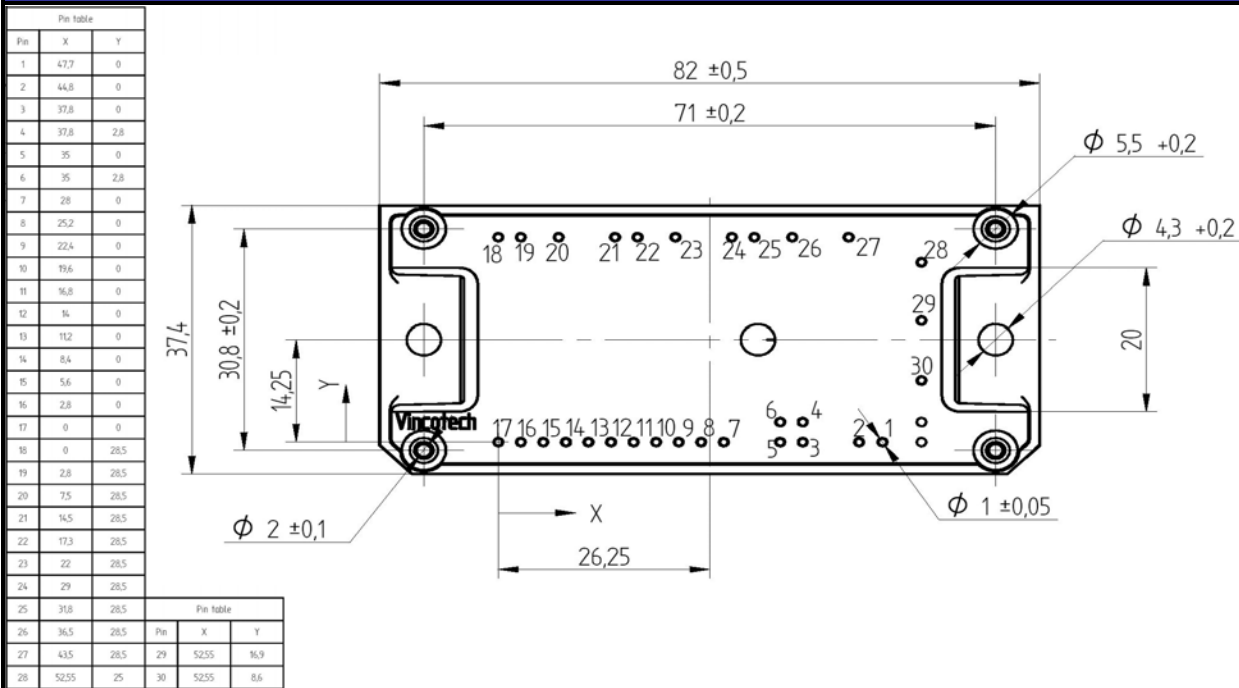

#### Pinout

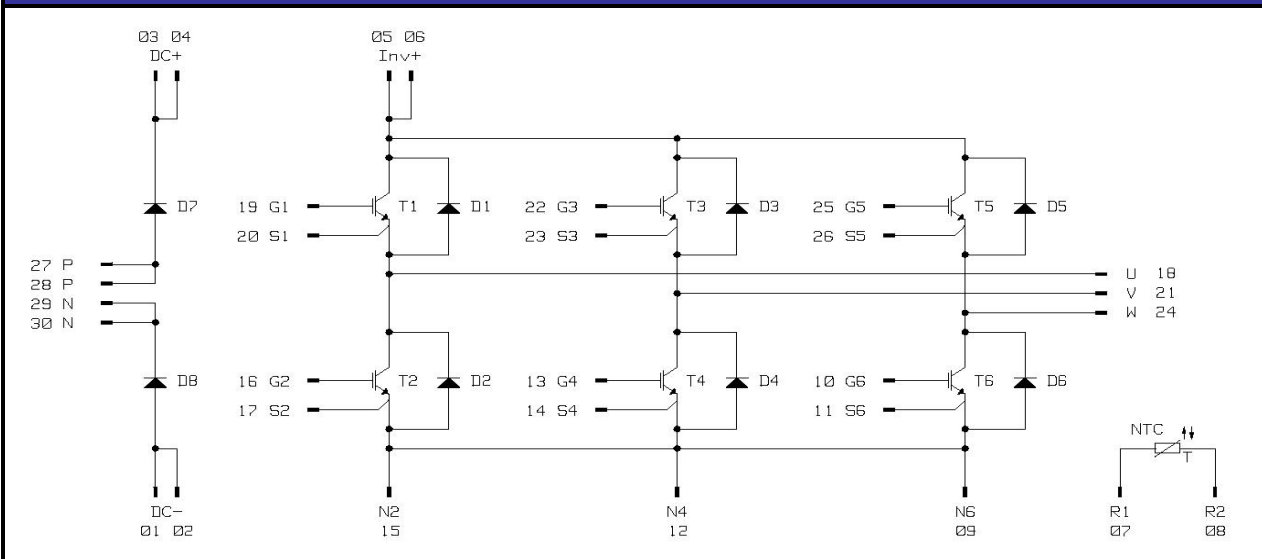

**PRODUCT STATUS DEFINITIONS**

<b>Datasheet Status</b>	<b>Product Status</b>	<b>Definition</b>
Target	Formative or In Design	This datasheet contains the design specifications for product development. Specifications may change in any manner without notice. The data contained is exclusively intended for technically trained staff.
Preliminary	First Production	This datasheet contains preliminary data, and supplementary data may be published at a later date. Vincotech reserves the right to make changes at any time without notice in order to improve design. The data contained is exclusively intended for technically trained staff.
Final	Full Production	This datasheet contains final specifications. Vincotech reserves the right to make changes at any time without notice in order to improve design. The data contained is exclusively intended for technically trained staff.

**DISCLAIMER**

The information given in this datasheet describes the type of component and does not represent assured characteristics. For tested values please contact Vincotech. Vincotech reserves the right to make changes without further notice to any products herein to improve reliability, function or design. Vincotech does not assume any liability arising out of the application or use of any product or circuit described herein; neither does it convey any license under its patent rights, nor the rights of others.

**LIFE SUPPORT POLICY**

Vincotech products are not authorised for use as critical components in life support devices or systems without the express written approval of Vincotech.

As used herein:

1. Life support devices or systems are devices or systems which, (a) are intended for surgical implant into the body, or (b) support or sustain life, or (c) whose failure to perform when properly used in accordance with instructions for use provided in labelling can be reasonably expected to result in significant injury to the user.
2. A critical component is any component of a life support device or system whose failure to perform can be reasonably expected to cause the failure of the life support device or system, or to affect its safety or effectiveness.