



ON Semiconductor®

<http://onsemi.com>

# LB11873

Monolithic Digital IC

For Polygonal Mirror Motors

Three-Phase Brushless Motor Driver

## Overview

The LB11873 is a 3-phase brushless motor driver developed for driving the polygonal mirror motor used in plain-paper copiers and similar products. This IC can implement the circuits required for polygonal mirror motor drive (speed control and driver circuits) in a single chip.

The LB11873 implements low-noise/low-vibration PWM drive by changing the current at phase switching gradually to reduce motor noise.

## Functions

- Three-phase bipolar drive (quiet direct PWM)
- PLL speed control circuit
- Hall sensor FG support
- Dedicated external clock
- Brake mode switching circuit (free running and reverse braking)
- Phase lock detection output (with masking function)
- Built-in current limiter, constraint protection, undervoltage protection, thermal protection, and CLK line disconnection protection circuits
- Input pins support 3V system microcontrollers

## Specifications

**Absolute Maximum Ratings** at  $T_a = 25^\circ\text{C}$

Parameter	Symbol	Conditions	Ratings	Unit
Supply voltage	$V_{CC}$ max		30	V
Output current	$I_O$ max	$T \leq 500\text{ms}$	1.8	A
Allowable power dissipation 1	$P_d$ max1	Independent IC	0.9	W
Allowable power dissipation 2	$P_d$ max2	When mounted on a circuit board *1	2.1	W
Operating temperature	$T_{opr}$		-20 to +80	$^\circ\text{C}$
Storage temperature	$T_{stg}$		-55 to +150	$^\circ\text{C}$

\*1 Specified circuit board :  $114.3 \times 76.1 \times 1.6\text{mm}^3$ , glass epoxy.

Stresses exceeding Maximum Ratings may damage the device. Maximum Ratings are stress ratings only. Functional operation above the Recommended Operating Conditions is not implied. Extended exposure to stresses above the Recommended Operating Conditions may affect device reliability.

# LB11873

## Allowable Operating Ranges at $T_a = 25^\circ\text{C}$

Parameter	Symbol	Conditions	Ratings	Unit
Supply voltage range	$V_{CC}$		9.5 to 28	V
5V constant voltage output	I <sub>REG</sub>		0 to -30	mA
LD pin apply voltage	V <sub>LD</sub>		0 to 28	V
LD pin output current	I <sub>LD</sub>		0 to 15	mA
FGS pin apply voltage	V <sub>FGS</sub>		0 to 28	V
FGS pin output current	I <sub>FGS</sub>		0 to 10	mA
HB pin apply voltage	V <sub>HBS</sub>		0 to 28	V
HB pin output current	I <sub>HBS</sub>		0 to 30	mA

## Electrical Characteristics at $T_a = 25^\circ\text{C}$ , $V_{CC} = V_M = 24\text{V}$

Parameter	Symbol	Conditions	Ratings			Unit
			min	typ	max	
Supply current 1	I <sub>CC1</sub>			22	28	mA
Supply current 2	I <sub>CC2</sub>	Stop mode		4.0	6.0	mA
<b>5V constant voltage output (VREG pin)</b>						
Output voltage	V <sub>REG</sub>		4.65	5.0	5.35	V
Line regulation	$\Delta V_{REG1}$	$V_{CC} = 9.5$ to $28\text{V}$		80	130	mV
Load regulation	$\Delta V_{REG2}$	$I_O = -5$ to $-20\text{mA}$		10	60	mV
Temperature coefficient	$\Delta V_{REG3}$	Design target*		0		mV/°C
<b>Output Block</b>						
Output saturation voltage 1	V <sub>Osat1</sub>	$I_O = 0.5\text{A}$ , $V_O$ (sink) + $V_O$ (source)		1.4	1.9	V
Output saturation voltage 2	V <sub>Osat2</sub>	$I_O = 1.2\text{A}$ , $V_O$ (sink) + $V_O$ (source)		2.0	2.6	V
Output leakage current	I <sub>Oleak</sub>				100	μA
High side diode forward voltage 1	V <sub>D2-1</sub>	$I_D = 0.5\text{A}$		1.0	1.5	V
High side diode forward voltage 2	V <sub>D2-2</sub>	$I_D = 1.2\text{A}$		1.5	2.0	V
<b>Hall Sensor Amplifier Block</b>						
Input bias current	I <sub>HB</sub>			2	10	μA
Differential input range	V <sub>IHIN</sub>	Sine wave input	50		350	
Common-mode input voltage range	V <sub>ICM</sub>		1.5		V <sub>REG</sub> - 1.0	V
Input offset voltage	V <sub>IOH</sub>	Design target value*	-20		20	mV
<b>Hall Sensor Bias</b>						
Output saturation voltage	V <sub>OL</sub> (HB)	$I_{HB} = 10\text{mA}$	1.5		2.0	V
Output leakage current	I <sub>L</sub> (HB)	$V_O = V_{CC}$ , stop mode			10	μA
<b>FG Schmitt Trigger Block (IN1)</b>						
Input amplifier gain	G <sub>FG</sub>	Design target value*		5		Times
Input hysteresis (high → low)	V <sub>SHL</sub>	Design target value*		0		mV
Input hysteresis (low → high)	V <sub>SLH</sub>	Design target value*		-10		mV
Hysteresis	V <sub>FGL</sub>	Input conversion, design target value *	4	7	12	mV
<b>PWM Oscillator</b>						
High-level output voltage	V <sub>OH</sub> (PWM)		2.65	2.95	3.25	V
Low-level output voltage	V <sub>OL</sub> (PWM)		0.9	1.2	1.5	V
External capacitor charge current	I <sub>CHG</sub>	VPWM = 2V	-60	-45	-30	μA
Oscillator frequency	f (PWM)	C = 680pF		34		kHz
Amplitude	V (PWM)		1.45	1.75	2.05	V <sub>p-p</sub>

\* The design specification items are design guarantees and are not measured.

Continued on next page.

# LB11873

Continued from preceding page.

Parameter	Symbol	Conditions	Ratings			Unit
			min	typ	max	
<b>FGS Pin</b>						
Output saturation voltage	$V_{OL}$ (FGS)	IFGS = 7mA		0.15	0.5	V
Output leakage current	$I_L$ (FGS)	$V_O = V_{CC}$			10	$\mu$ A
<b>CSD Oscillator Circuit</b>						
Oscillator frequency	f (CSD)	C = 0.033 $\mu$ F		31		Hz
High-level output voltage	$V_{OH}$ (CSD)		3.50	3.75	4.00	V
Low-level output voltage	$V_{OL}$ (CSD)		1.00	1.30	1.60	V
Amplitude	V (CSD)		2.20	2.45	2.80	V <sub>p-p</sub>
External capacitor charge current	ICHG1	VCSD = 2V	-7	-5	-3	$\mu$ A
External capacitor discharge current	ICHG2	VCSD = 2V	3	5	7	$\mu$ A
Lock detection delay counts	CSDCT1			7		
Clock disconnected protection counts	CSDCT2			2		
Constraint protection operation counts	CSDCT3			31		
Initial reset voltage	VRES			0.6	0.8	V
<b>Phase Comparator Output</b>						
High-level input voltage	VPDH	$I_{OH} = -100\mu$ A	VREG - 0.2	VREG - 0.1		V
Low-level input voltage	VPDL	$I_{OL} = 100\mu$ A		0.2	0.3	V
Input source current	IPD+	VPD = VREG/2			-0.5	mA
Input sink current	IPD-	VPD = VREG/2	1.5			mA
<b>Phase Lock Detection Output</b>						
Output saturation voltage	$V_{OL}$ (LD)	$I_{LD} = 10$ mA		0.15	0.5	V
Output leakage current	$I_L$ (LD)	$V_O = V_{CC}$			10	$\mu$ A
<b>Error Amplifier Block</b>						
Input offset voltage	$V_{IO}$ (ER)	Design target value*	-10		10	mV
Input bias current	IB (ER)		-1		1	$\mu$ A
High-level output voltage	$V_{OH}$ (ER)	IEI = -0.1mA, no load	3.7	4.0	4.3	V
Low-level output voltage	$V_{OL}$ (ER)	IEI = 0.1mA, no load	0.7	1.0	1.3	V
DC bias level	VB (ER)		-5%	VREG/2	5%	V
<b>Current Limiter Circuit</b>						
Drive gain 1	GDF1	In the phase locked state	0.4	0.5	0.6	Times
Drive gain 2	GDF2	In the unlocked state	0.8	1.0	1.2	Times
Limiter voltage 1	VRF1	$V_{CC} - V_M$ , forward mode	0.45	0.5	0.55	V
Limiter voltage 2	VRF2	$V_{CC} - V_M$ , reverse mode	0.225	0.25	0.275	V
<b>Thermal shutdown circuit</b>						
Thermal shutdown operating temperature	TSD	Design target value* (junction temperature)	150	170		$^{\circ}$ C
Thermal shutdown temperature hysteresis	$\Delta$ TSD	Design target value* (junction temperature)		40		$^{\circ}$ C
<b>Low Voltage Protection Circuit</b>						
Operating voltage	VSDL		8.1	8.45	8.9	V
Hysteresis	$\Delta$ VSD		0.2	0.35	0.5	V
<b>CLK pin</b>						
External input frequency	fI (CLK)		0.1		10	kHz
High-level input voltage	$V_{IH}$ (CLK)		2.0		VREG	V
Low-level input voltage	$V_{IL}$ (CLK)		0		1.0	V
Input open voltage	VIO (CLK)			3.0		V
Hysteresis	VIS (CLK)			0.25		V
High-level input current	$I_{IH}$ (CLK)	VCKIN = VREG		115	150	$\mu$ A
Low-level input current	$I_{IL}$ (CLK)	VCKIN = 0V	-220	-175		$\mu$ A

Continued on next page.

Note : \* The design specification items are design guarantees and are not measured.

# LB11873

Continued from preceding page.

Parameter	Symbol	Conditions	Ratings			Unit
			min	typ	max	
<b>S/S pin</b>						
High-level input voltage	$V_{IH}$ (SS)		2.0		VREG	V
Low-level input voltage	$V_{IL}$ (SS)		0		1.0	V
Input open voltage	VIO (SS)			3.0		V
Hysteresis	VIS (SS)		0.21	0.25	0.29	V
High-level input current	$I_{IH}$ (SS)	VS/S = VREG		115	150	$\mu$ A
Low-level input current	$I_{IL}$ (SS)	VS/S = 0V	-220	-175		$\mu$ A
<b>BRSEL pin</b>						
High-level input voltage	$V_{IH}$ (BRSEL)		2.0		VREG	V
Low-level input voltage	$V_{IL}$ (BRSEL)		0		1.0	V
Input open voltage	VIO (BRSEL)			3.0		V
Hysteresis	VIS (BRSEL)		0.21	0.25	0.29	V
High-level input current	$I_{IH}$ (BRSEL)	VBRSEL = VREG		115	150	$\mu$ A
Low-level input current	$I_{IL}$ (BRSEL)	VBRSEL = 0V	-220	-175		$\mu$ A

## Package Dimensions

unit : mm (typ)

3235A

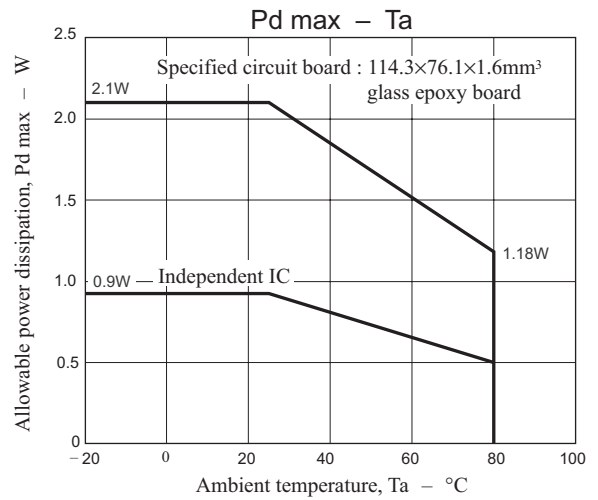
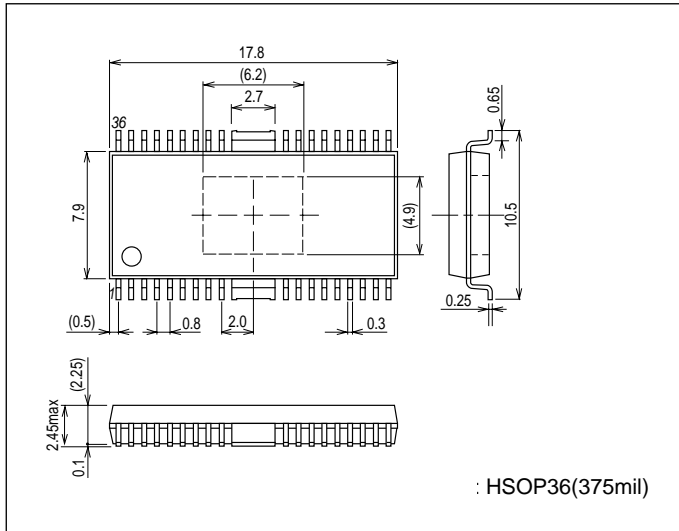

## Three-Phase Logic Truth Table (The input "H" state is the state where IN+ > IN-)

IN1	IN2	IN3	OUT1	OUT2	OUT3
H	L	H	L	H	M
H	L	L	L	M	H
H	H	L	M	L	H
L	H	L	H	L	M
L	H	H	H	M	L
L	L	H	M	H	L

### S/S pin

Input state	State
High or open	Stop
Low	Start

### BRSEL pin

Input state	During deceleration
High or open	Free running
Low	Reverse braking

# LB11873

## Pin Assignment

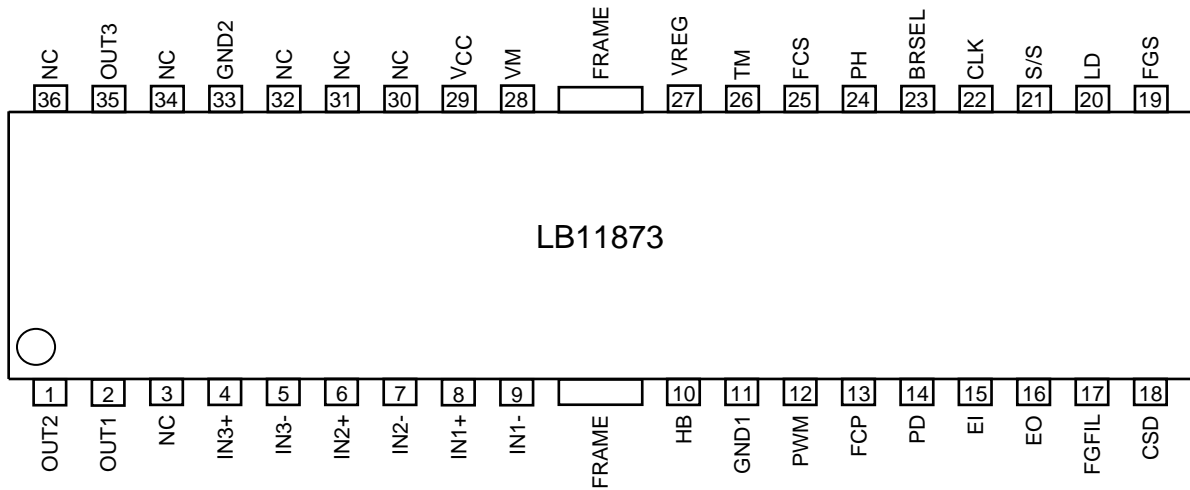

Top view

## Hall sensor input waveforms and output current waveform

(1) When the Hall sensor input amplitude is small or when the input waveform slope is low

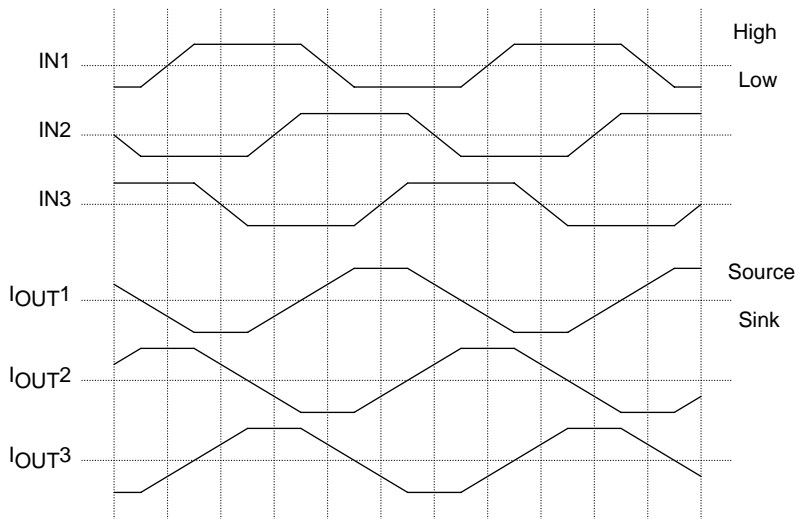

180° drive: Current flows during all periods; there are on off periods (180° drive)

(2) When the Hall sensor input amplitude is larger or when the input waveform slope is steep

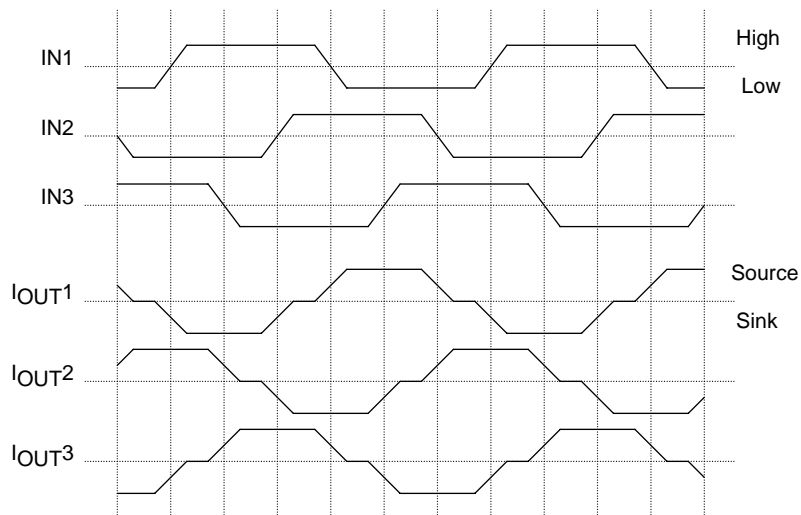

In this case, periods in which drive is off will occur (the off periods vary depending on the Hall sensor inputs).

# LB11873

## Internal Equivalent Circuit Block Diagram and External Reference Circuit

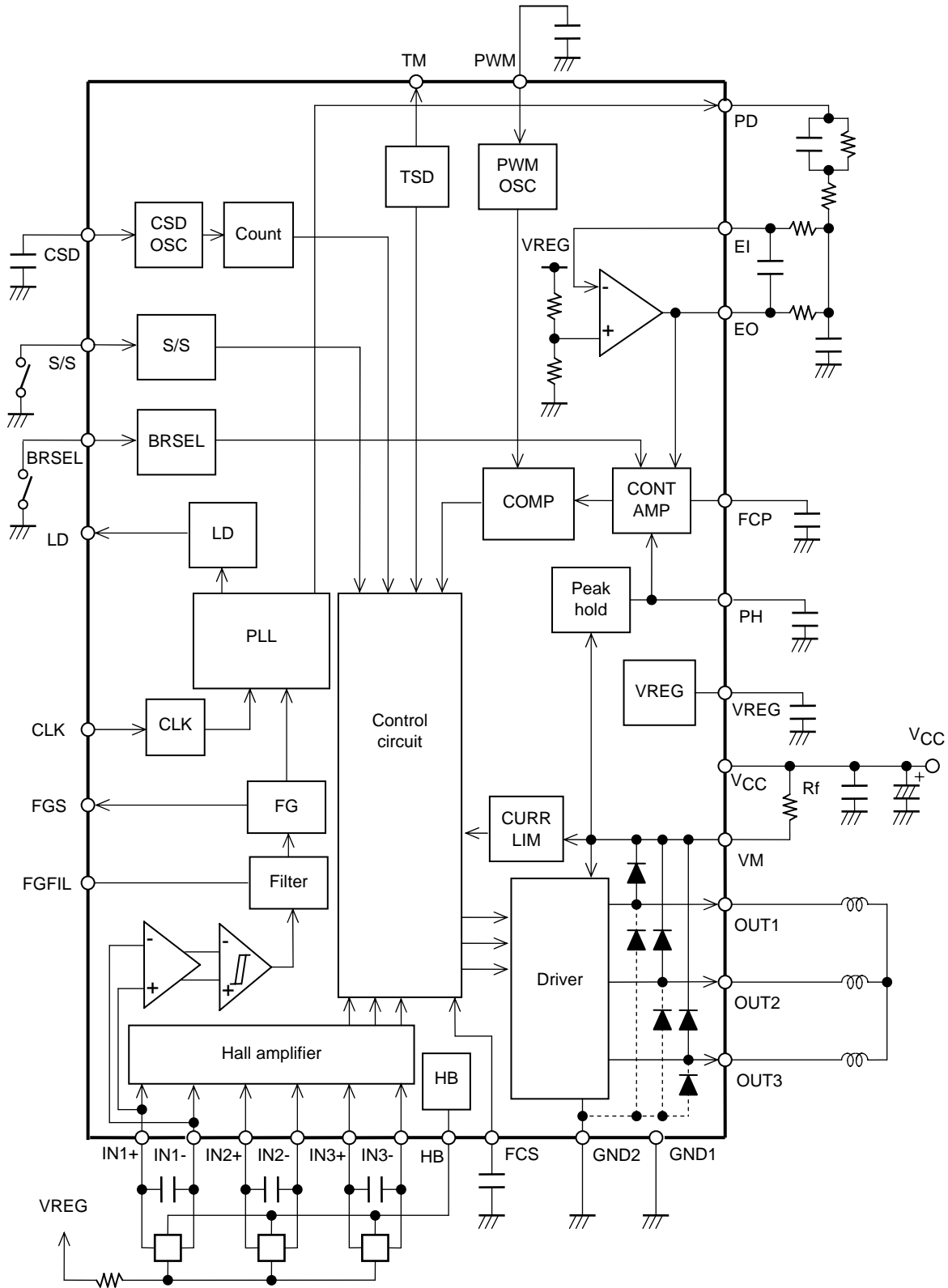

Pin Functions

Pin No.	Pin	Description	Equivalent Circuit
2 1 35	OUT1 OUT2 OUT3	Motor drive outputs	
33	GND2	Output block ground	
28	VM	Motor drive output power supply and output current detection Connect a resistor (Rf) between this pin and VCC. The output current will be limited to the value $I_{OUT} = V_{RF}/R_f$ .	
8 9 6 7 4 5	IN1+ IN1- IN2+ IN2- IN3+ IN3-	Hall sensor inputs "H" is the state where $IN+ > IN-$ , and "L" is the reverse state. It is desirable that the Hall sensor signals have an amplitude greater than 50 mVpp If noise on the Hall sensor signals is a problem, connect capacitors between the IN+ and IN- inputs.	
10	HB	Hall sensor element bias current This circuit is turned off in stop mode.	
11	GND1	Control circuit block ground	
12	PWM	Sets the PWM oscillator frequency. Connect a capacitor between this pin and ground. A 680pF capacitor sets the oscillator frequency to be about 34kHz.	

Continued on next page.

# LB11873

Continued from preceding page.

Pin No.	Pin	Description	Equivalent Circuit
13	FCP	<p>Current limiter circuit frequency characteristics correction</p> <p>Connect a capacitor (about 0.01<math>\mu</math>F to 0.1<math>\mu</math>F) between this pin and ground.</p> <p>The output duty is determined by comparing the voltage at this pin with the PWM oscillator waveform.</p>	
14	PD	<p>Phase comparator output</p> <p>The phase error is converted to a pulse duty and output from this pin.</p>	
15	EI	Error amplifier input	
16	EO	Error amplifier output	
17	FGFIL	<p>FG filter</p> <p>This pin is normally left open. If noise on the FG signal is a problem, connect a capacitor (about 20pF or smaller) between this pin and ground.</p>	

Continued on next page.



# LB11873

Continued from preceding page.

Pin No.	Pin	Description	Equivalent Circuit
18	CSD	Initial reset pulse generation and protection circuit reference oscillator Connect a capacitor between this pin and ground.	
19	FGS	FG Schmitt trigger output	
20	LD	Phase lock detection output This output goes to the on state (low-level output) in the phase locked state.	
21	S/S	Start/stop control Low : 0V to 1.0V High : 2.0V to VREG Hysteresis : about 0.25V This pin goes to the high level when open. A low level specifies the start state.	
22	CLK	Clock input Low : 0V to 1.0V High : 2.0V to VREG Hysteresis : about 0.25V $f_{CLK} = 10\text{kHz max.}$ If there is noise on this signal, insert a noise rejection capacitor at this input.	

Continued on next page.

# LB11873

Continued from preceding page.

Pin No.	Pin	Description	Equivalent Circuit
23	BRSEL	Deceleration (braking) control selection Low : 0V to 1.0V High : 2.0V to VREG This pin goes to the high level when open. A low level selects reverse torque control and a high level selects free running braking. If reverse torque control is used, an external Schottky barrier diode will be required on the low side of the output.	
24	PH	RF waveform smooth Connect a capacitor between this pin and ground.	
25	FCS	Control loop frequency characteristics correction Connect a capacitor between this pin and ground.	
26	TM	Monitor output This pin is normally left open.	

Continued on next page.

# LB11873

Continued from preceding page.

Pin No.	Pin	Description	Equivalent Circuit
27	VREG	Stabilized power supply output (5V output) Connect a capacitor between this pin and ground for power supply stabilization. (About 0.1μF)	
29	V <sub>CC</sub>	Power supply. Connect a capacitor (a few tens of μF or larger) between this pin and ground so that noise does not enter the IC.	
3, 30 31, 32 34, 36	NC	Since this pin is not connected internally to the chip, it can be used for wiring connections.	
	FRAME	Connect this pin to ground.	

## LB11873 Overview

### 1. Speed control circuit

Since the LB11873 adopts PLL speed control, it provides precise, low-jitter, and stable motor operation. This PLL circuit compares the falling edge of the CLK signal with the FG signal (edges on which the IN1 input changes from low to high and FGS output rising edges) and controls motor operation based on the difference.

During control operation, the FG servo frequency is the same as the CLK signal frequency.

$$f_{FG} (\text{servo}) = f_{CLK}$$

### 2. Output drive circuit

This IC minimizes motor vibration and noise by changing the output current smoothly during phase switching. Since the change (slope) imposed on the output current during phase switching uses the slope of the Hall sensor input waveform, the changes in the output waveforms at phase switching will become too steep if the Hall sensor input waveform slope is steep. This will reduce the noise and vibration reducing effect of this technique. Thus care is required concerning the slope of the Hall sensor input waveform.

Low side output transistor PWM switching is used for motor speed control and the drive output is adjusted by changing the duty. The diode between OUT and VM used for the regenerative current when the PWM is off is built into this IC. Due to the parasitic diode between OUT and ground, if reverse control mode (torque braking) is selected for braking, an external Schottky barrier diode must be used. Also, if there are problems when the output current is large (for example, incorrect operation or waveform disruption during low side kickback) a Schottky barrier diode must be connected between OUT and ground.

Note that if it is necessary to reduce IC thermal dissipation during constant-speed operation, it may be effective to insert a Schottky barrier diode between OUT and VM. This effect occurs because the regenerative current during PWM switching will be dissipated in the external diode instead of the IC's internal diode.

### 3. Current limiter circuit

The current limiter circuit limits the drive current to a current determined by the equation  $I = V_{RF}/R_f$ , where  $V_{RF} = 0.5V$  (typical) and  $R_f$  is the current detection resistor. The limiting operation works by reducing other output on duty to suppress the drive current.

The current limiter circuit detects the reverse recovery current due to PWM operation and, to assure that the current limiting operation is not performed incorrectly, provides a delay of about  $2\mu s$  before it operates. Since the changes in the current levels at startup (the state where there is no counterelectromotive force from the motor) will be rapid if either the motor coil resistance is low or if the inductance is low, there are cases where current limiter will operate at a current level above that set due to this delay. In these cases, it will be necessary to take the amount of current increase due to the delay into account when setting the current limit value.

#### **4. Power saving circuit**

This IC goes into a power saving state in which current drain is reduced when set to the stop state. This power saving state is implemented by cutting the bias current to most of the circuits in the IC. The 5V regulator output, however, is still output when the IC is in the power saving state.

#### **5. Reference clock**

Care must be taken to assure that no noise due to chattering or other problems appears on the externally input clock signal. While the input circuit is designed with hysteresis, noise must be rejected by, for example, inserting capacitors in the clock line if noise problems occur.

The LB11873 provides a built-in clock disconnection protection circuit. At clock frequencies lower than the frequency determined by the following equation, the LB11873 will not perform its normal control operation, but rather will operate in an intermittent mode.

$$f \text{ (Hz)} \approx 1.02 \div \text{CCSD} \quad \text{CCSD } (\mu\text{F}) : \text{ the capacitor connected between the CSD pin and ground.}$$

If a 0.033 $\mu$ F capacitor is used, the frequency will be about 31Hz.

If the IC is set to the start state with absolutely no clock signal provided, the motor will first start to turn somewhat and then the drive will be turned off.

If motor rotation stops, a time in excess of the constraint protection operating time elapses, and then the clock signal is applied again, drive operation will not be restarted. However, if the clock signal is reapplied before the constraint protection circuit operates, drive operation will restart.

#### **6. PWM frequency**

The PWM frequency is determined by the capacitance of the capacitor (C) connected to the PWM pin.

$$f_{\text{PWM}} \approx 1/(43000 \times C)$$

If a 680pF capacitor is used, the circuit will oscillate at about 34kHz. If the PWM frequency is too low the motor will emit switching noise, and if it is too high the power loss in the output will increase. A frequency in the range 15kHz to 50kHz is desirable. This capacitor must be connected between this pin and the GND pin by lines that are as short as possible to make this circuit immune to noise.

The capacitor ground side must be connected as close as possible to the IC control block ground (the GND1 pin), to minimize the influence of the output.

#### **7. Hall sensor input signals**

The Hall sensor input signals must have an amplitude (differential) of over 50mVpp. If disruption of the output waveforms occurs due to noise on these signals, capacitors must be connected between the Hall sensor inputs (between the + and - sides).

#### **8. FCS pin**

The capacitor (about 0.1 $\mu$ F) connected to the FC pin is required for correction of the control loop frequency characteristics.

#### **9. Constraint protection circuit**

The LB11873 includes a built-in constraint protection circuit to protect the IC and the motor if the motor is physically constrained from turning.

If FG signal (one side edge of IN1) does not switch states for a period in excess of a certain fixed time in the start state, the PWM drive side output is turned off.

The time is set by the capacitor connected to the CSD pin.

$$\text{Set time (seconds)} \approx 30.5 \times 0.98 \times \text{CCSD } (\mu\text{F})$$

If a 0.033 $\mu$ F capacitor is used, the protection operation time will be about 0.99 seconds.

The constraint protection state can be cleared by either switching to the stop state (and remaining for over 100 $\mu$ s) or turning the power off and then on again. Note that the constraint protection circuit may not operate correctly if there is noise on the FG signal when the motor is physically constrained.

**10. Phase lock signal****(1) Phase lock range**

Since this IC does not have a speed system counter, the speed error range in the phase locked state cannot be determined by the IC characteristics alone. (This is because the range is affected by the acceleration with changes in the FG frequency.) If it is necessary to stipulate this in conjunction with a motor, it will be necessary to measure the range with the actual motor state. Since speed errors occur easily in states where the FG acceleration is large, it is thought that the lock pull-in time at startup and the unlock time due to clock switching will be the cases where the speed error is the largest.

**(2) Phase lock signal mask function**

It is possible to assure that the lock signal is output in stable states by masking the short-term low levels due to hunting during lock pull-in. Note, however, that the lock signal output will be delayed by the amount of the mask time.

The mask time is set by the capacitor connected between the CLD pin and ground.

$$\text{Mask time (s)} \approx 6.5 \times 0.98 \times \text{CCSD} (\mu\text{F})$$

When a 0.033 $\mu\text{F}$  capacitor is used, the mask time will be about 210ms. If full masking is required, the mask time must be set with an adequate margin.

**11. Initial reset**

To apply an initial reset to the logic circuit, the IC goes to the reset state until the CSD pin voltage changes from 0V to about 0.63V. After the reset is cleared, drive will start. The reset time can be calculated quite closely with the following equation.

$$\text{Reset time (s)} \approx 0.13 \times \text{CCSD} (\mu\text{F})$$

A reset time of over 100 $\mu\text{s}$  is required.

**12. Power supply stabilization**

Since this IC is used in switching drive applications with large output currents, the power supply line is easily disrupted.

Therefore it is necessary to connect an adequately large capacitor between the VCC pin and ground.

The capacitor ground side is connected to the GND2 pin, which is the power system ground, and must be connected as close as possible to the pin.

If the capacitor (an electrolytic capacitor) cannot be connected close to the pin, a ceramic capacitor of about 0.1 $\mu\text{F}$  must be connected close to the pin.

If reverse control mode (torque braking) is selected for braking, since there will be states where the current returns to the power supply, the power supply line level will be especially subject to disruption. Since the power supply line is most easily disrupted during lock pull-in at high speeds, designers must analyze this case carefully and select an adequately large capacitor.

Since the power supply line is particularly susceptible to disruption if a diode is inserted in the power supply line to prevent destruction of the IC by reverse connection, an even larger capacitor must be selected in this case.

**13. VREG stabilization**

Connect a capacitor with a value over 0.1 $\mu\text{F}$  to stabilize the VREG voltage, which is the IC's control circuit power supply. This capacitor's ground side must be connected as close as possible to the IC's control block ground (the GND1 pin).

**14. Error amplifier system components**

The external components for the error amplifier block must be located as close as possible to the IC to minimize the influence of noise. These components must also be located as far from the motor as possible.

**15. FRAME pin**

An electrolytic capacitor must be connected between the FRAME pin and GND2 with the capacitor's ground side is connected to GND2.

ON Semiconductor and the ON logo are registered trademarks of Semiconductor Components Industries, LLC (SCILLC). SCILLC owns the rights to a number of patents, trademarks, copyrights, trade secrets, and other intellectual property. A listing of SCILLC's product/patent coverage may be accessed at [www.onsemi.com/site/pdf/Patent-Marking.pdf](http://www.onsemi.com/site/pdf/Patent-Marking.pdf). SCILLC reserves the right to make changes without further notice to any products herein. SCILLC makes no warranty, representation or guarantee regarding the suitability of its products for any particular purpose, nor does SCILLC assume any liability arising out of the application or use of any product or circuit, and specifically disclaims any and all liability, including without limitation special, consequential or incidental damages. "Typical" parameters which may be provided in SCILLC data sheets and/or specifications can and do vary in different applications and actual performance may vary over time. All operating parameters, including "Typicals" must be validated for each customer application by customer's technical experts. SCILLC does not convey any license under its patent rights nor the rights of others. SCILLC products are not designed, intended, or authorized for use as components in systems intended for surgical implant into the body, or other applications intended to support or sustain life, or for any other application in which the failure of the SCILLC product could create a situation where personal injury or death may occur. Should Buyer purchase or use SCILLC products for any such unintended or unauthorized application, Buyer shall indemnify and hold SCILLC and its officers, employees, subsidiaries, affiliates, and distributors harmless against all claims, costs, damages, and expenses, and reasonable attorney fees arising out of, directly or indirectly, any claim of personal injury or death associated with such unintended or unauthorized use, even if such claim alleges that SCILLC was negligent regarding the design or manufacture of the part. SCILLC is an Equal Opportunity/Affirmative Action Employer. This literature is subject to all applicable copyright laws and is not for resale in any manner.