

VIDEO AMPLIFIER

DEVICE DESCRIPTION

The ZXFV202 is a single high speed amplifier designed for video and other high speed applications. Packaged in a small SOT23-5 it is ideally suited to applications where space is at a premium. In applications where cross talk is critical this part provides better isolation than dual or quad devices.

It features low differential gain and phase performance. High output drive capability compliments this part for use in video applications.

FEATURES AND BENEFITS

- Unity gain bandwidth 300MHz
- Slew rate 400V/ μ s
- Differential gain 0.01%
- Differential phase 0.01°
- Output current 40mA
- Characterised up to 400pF load
- \pm 5 Volt supply
- Supply current 7mA
- Packaged in SOT23-5 or 8 pin SO

APPLICATIONS

- Video gain stages
- CCTV buffer
- Video distribution
- RGB buffering
- xDSL
- Home theatre
- Fast ADC signal input drive
- High frequency instrumentation
- Cable Driving
- Radar Imaging
- Medical Imaging

ORDERING INFORMATION

SOT23-5 package

PART NUMBER	CONTAINER	INCREMENT
ZXFV202E5TA	Reel 7"	3000
ZXFV202E5TC	Reel 13"	10000

SO8 package

PART NUMBER	CONTAINER	INCREMENT
ZXFV202N8TA	Reel 7"	500
ZXFV202N8TC	Reel 13"	2500

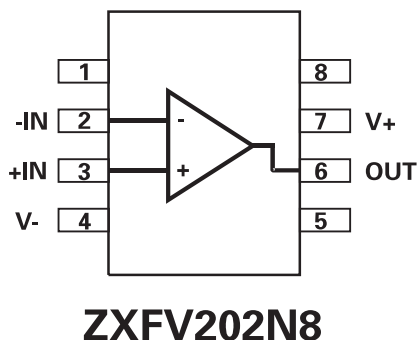
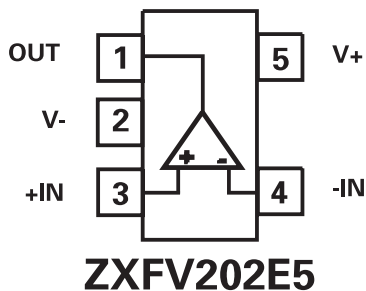

ZXFV202

ABSOLUTE MAXIMUM RATINGS

Supply Voltage	11V	
Inputs to ground*	V+ -0.5V to V- -0.5V	
Operating Ambient Temperature Range	-40°C to 85°C	Storage -65°C to 150°C
Operating Temperature Range T _{JMAX} **	150°C	

**The thermal resistance from the semiconductor die to ambient is typically 195°C/W when the SOT23-5 package is mounted on a PCB in free air. The power dissipation of the device when loaded must be designed to keep the device junction temperature below T_{JMAX}. Similarly, the SO8 package thermal resistance is typically 168°C/W.

*During power-up and power-down, these voltage ratings require an appropriate sequence of applying and removing signals and power supplies.

ESD: This device is sensitive to static discharge and proper handling precautions are required.

ELECTRICAL CHARACTERISTICS

Test Conditions: V_{CC}=±5V, T_{amb}= 25°C unless otherwise stated. R_f=1kΩ, R_L= 150Ω, C_L≤ 10pF

Parameter	Conditions	Test	Min.	Typ.	Max.	Units
Supply Voltage V+ Operating range			4.75	5	5.25	V
Supply Voltage V- Operating range			-5.25	-5	-4.75	V
Supply current		P	5	7	9	mA
Input Common mode Voltage range		P		±3		V
Input offset voltage		P		1	10	mV
Output offset voltage		P		2	20	mV
Input bias current, non inverting input		P		5	10	μA
Input Resistance		P	1.5	2	6.5	MΩ
Open loop gain		P	48	61		dB
Output voltage swing		P		±3		V
Output drive current		P	40			mA
Positive PSRR		P	49	57		dB
Negative PSRR		P	51	58		dB
Bandwidth	A _v = +1, V _{out} =200mV pk-pk	C		300		MHz
Slew rate	A _v = +1, V _{out} =2V pk-pk	C		400		V/μs
	A _v = +2, V _{out} =2V pk-pk	C		400		
	A _v = +10, V _{out} =2V pk-pk	C		400		
Rise time	V _{out} = 61 V, 10% - 90%	C		4.0		ns
Fall time	V _{out} = ±1V, 10% - 90%	C		3.2		ns
Propagation delay	V _{out} = ±2 V, 50%	C		4		ns
Differential Gain	3.6MHz (NTSC) & 4.4MHz (PAL)	C		0.01		%
Differential phase	3.6MHz (NTSC) & 4.4MHz (PAL)	C		0.01		deg

ZXFV202

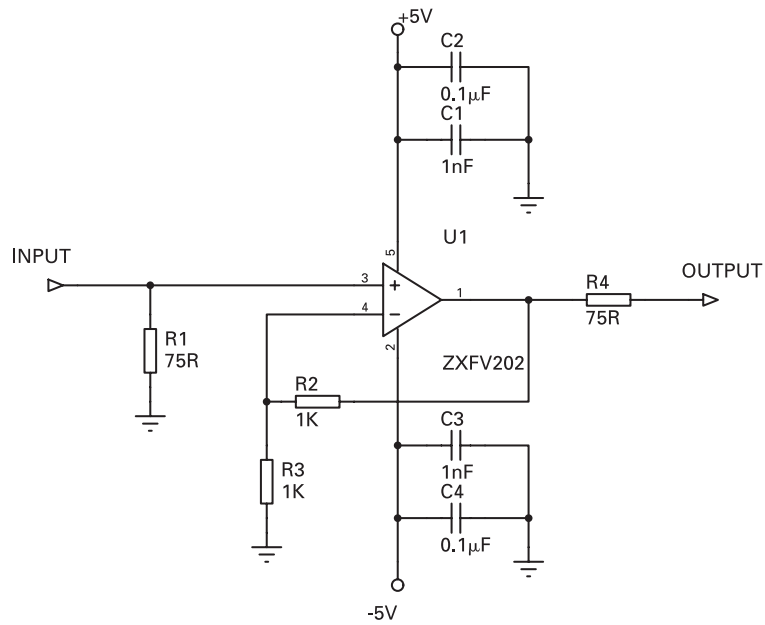

Figure 1: Typical Video Signal Application Circuit, Gain = 2(overall gain = 1 for 75Ω load)

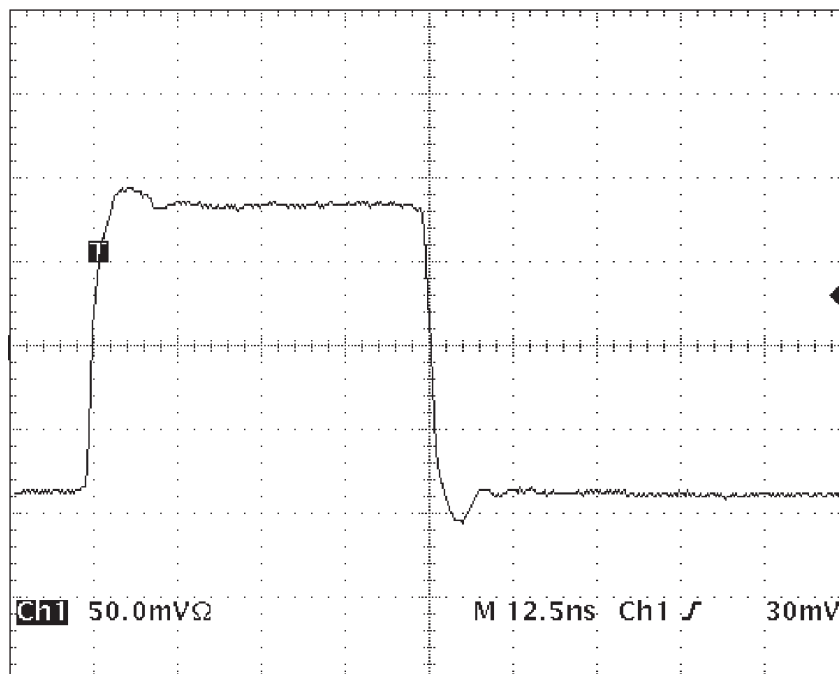

Figure 2: Pulse response, Unity gain, 1V pk-pk, $R_f = 510\Omega$

ZXFV202

APPLICATIONS INFORMATION

Introduction

A typical circuit application is shown in Figure 1, above. This is suitable for 75Ω transmission line connections at both the input and the output and is useful for distribution of wide-band signals such as video and xDSL via cables. The 75Ω reverse terminating resistor R4 gives the correct matching condition to a terminated video cable. The amplifier load is then 150Ω in parallel with the local feedback network.

The wide bandwidth of this device necessitates some care in the layout of the printed circuit. Partly for this reason, an Evaluation Circuit board is available and is described in a later paragraph. A continuous ground plane is required under the device and its signal connection paths, to provide the shortest possible ground return paths for signals and power supply filtering. A double-sided or multi-layer PCB construction is required, with plated-through via holes providing closely spaced low-inductance connections from some components to the continuous ground plane (some of these holes are not visible in the figures for the Evaluation Circuit Board – artworks and NC drill output can be provided if required).

For the power supply filtering, low inductance surface mount capacitors are normally required. It has been found that very good RF decoupling is provided on each supply using a 1000pF NPO size 0805 or smaller ceramic surface mount capacitor, closest to the device pin, with an adjacent 0.1μF X7R capacitor. Other configurations are possible and it may be found that a single 0.01μF X7R capacitor on each supply gives good results. However this should be supported by larger decoupling capacitors elsewhere on the printed circuit board. Values of 1 to 10 μF are recommended, particularly where the voltage regulators are located more than a few inches from the device. These larger capacitors are recommended to be solid tantalum electrolytic or ceramic types.

Note particularly that the inverting input of this current feedback type of amplifier is sensitive to small amounts of capacitance to ground which occur as part of the practical circuit board layout. This capacitance affects bandwidth, frequency response peaking and pulse overshoot. Therefore to minimise this capacitance, the feedback components R2 and R3 of Figure 1 should be positioned as close as possible to the inverting input connection.

The frequency response and pulse response will vary according to particular values of resistors and layout capacitance. The response can be tailored for the application to some extent by choice of the value of feedback resistor. Figure 2 shows an oscilloscope display of the pulse response of the Evaluation Circuit described below for RF = 510Ω.

Customer Evaluation Circuit

Figures 4 and 5 show the schematic and copper layout of a double-sided printed circuit board suitable for evaluation of the device in the laboratory. A parts list is provided below. This layout serves as a useful example for many applications, showing the practical implementation of the advice given above in the Introduction.

BNC connector sockets allow connection to test instruments via 50Ω cables. The output circuit includes a resistor matching circuit to present a load of 150 ohms to the amplifier and simultaneously provide 50 ohms output impedance. The attenuation of this matching circuit is 15.45 dB. As the amplifier is configured for a voltage gain of 2, the overall gain is:

$$6 - 15.45 = -9.45\text{dB.}$$

EVALUATION CIRCUIT PARTS LIST:

QTY	CCT-REF	VALUE	DESCRIPTION
Resistors, surface mount			
1	R1,	51R	0805
2	R2,R3	1k	0805
1	R4	120R	0805
1	R5	10R	0805
1	R6	62R	0805
Capacitors, surface mount			
2	C1,C2	1nF	25V ceramic 0805 X7R
2	C3,C4	100nF	50V ceramic 0805 NPO
2	C5,C6	10μF	16V Tant Elec size C
Integrated Circuits			
1	U1	—	Zetex ZXFV202N8
Miscellaneous			
2	J1,J2	—	BNC Socket, PCB straight flange, e.g. Tyco B35N14H999X99
1	J3	—	3-way PCB screw terminal block IMO 20.501/3SB



ZXFV202

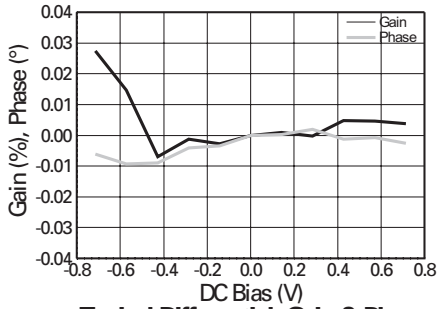

Typical Differential Gain & Phase Vs D.C Offset. PAL, 4.43MHz

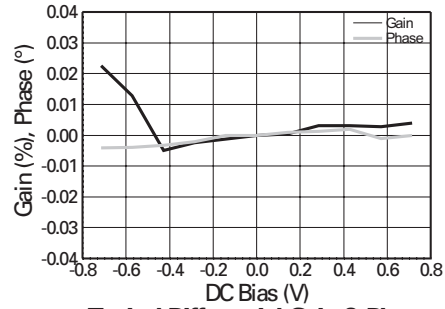

Typical Differential Gain & Phase Vs D.C Offset NTSC, 3.58MHz

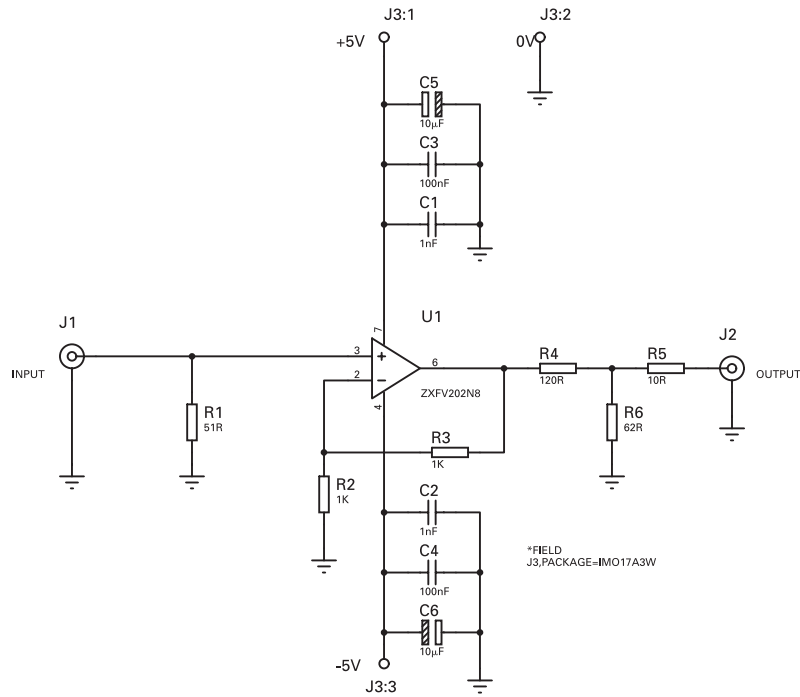

Figure 3: EVALUATION CIRCUIT SCHEMATIC

ZXFV202

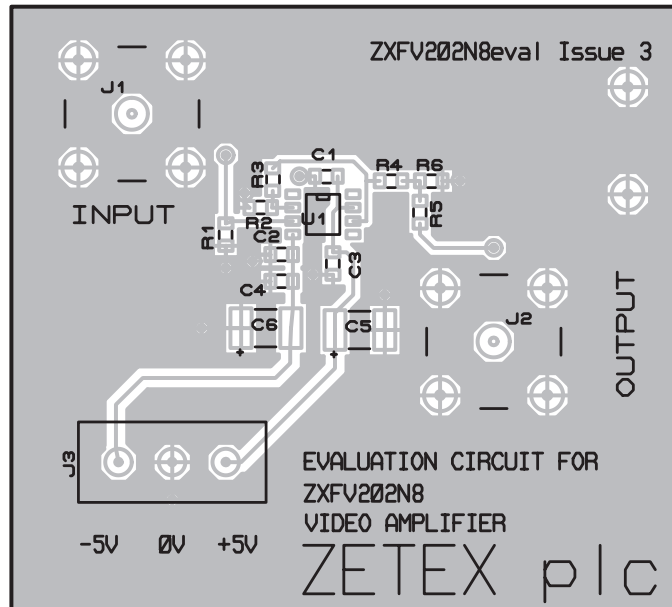

Figure 4 EVALUATION CIRCUIT TOP COPPER LAYOUT
(overall dimensions 2.5 x 2.25 inches)

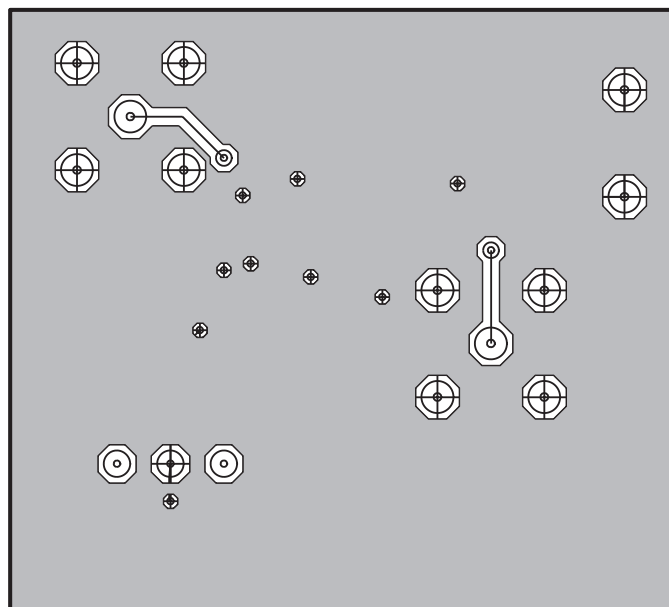
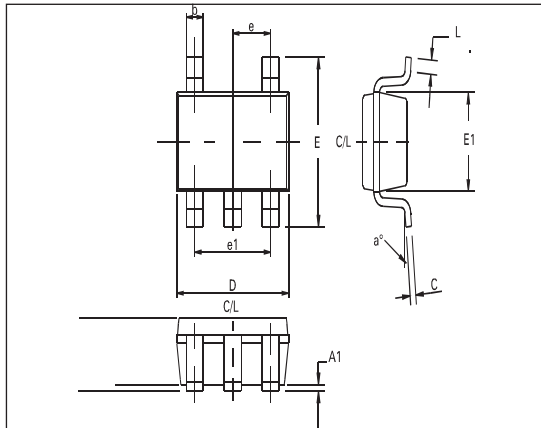

Figure 5: EVALUATION BOARD BOTTOM COPPER LAYOUT
(viewed through from top)

ZXFV202

SOT23-5 PACKAGE INFORMATION



SOT23-5 PACKAGE DIMENSIONS

DIM	MILLIMETRES		DIM	MILLIMETRES	
	MIN	MAX		MIN	MAX
A	0.90	1.45	E	2.20	3.20
A1	0.00	0.15	E1	1.30	1.80
A2	0.90	1.3	e	0.95 REF	
b	0.20	0.50	e1	1.90 REF	
C	0.09	0.26	L	0.10	0.60
D	2.70	3.10	a°	0	30

SO8 PACKAGE OUTLINE

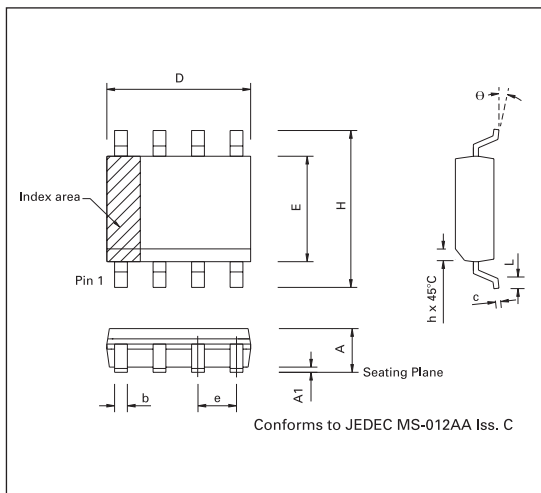

SO8 PACKAGE DIMENSIONS

DIM	INCHES		DIM	INCHES	
	MIN	MAX		MIN	MAX
A	0.053	0.069	e	0.050 BSC	
A1	0.004	0.010	b	0.013	0.020
D	0.189	0.197	c	0.008	0.010
H	0.228	0.244	Ø	Ø8	Ø8
E	0.150	0.157	h	0.010	0.020
L	0.016	0.050			

© Zetex plc 2002

Europe

Zetex plc
Fields New Road
Chadderton
Oldham, OL9 8NP
United Kingdom
Telephone: (44) 161 622 4422
Fax: (44) 161 622 4420
uksales@zetex.com

Zetex GmbH
Streitfeldstraße 19
D-81673 München

Germany
Telefon: (49) 89 45 49 49 0
Fax: (49) 89 45 49 49 49
europe.sales@zetex.com

Americas

Zetex Inc
700 Veterans Memorial Hwy
Hauppauge, NY11788

USA
Telephone: (631) 360 2222
Fax: (631) 360 8222
usa.sales@zetex.com

Asia Pacific

Zetex (Asia) Ltd
3701-04 Metroplaza, Tower 1
Hing Fong Road
Kwai Fong
Hong Kong
Telephone: (852) 26100 611
Fax: (852) 24250 494
asia.sales@zetex.com

These offices are supported by agents and distributors in major countries world-wide.

This publication is issued to provide outline information only which (unless agreed by the Company in writing) may not be used, applied or reproduced for any purpose or form part of any order or contract or be regarded as a representation relating to the products or services concerned. The Company reserves the right to alter without notice the specification, design, price or conditions of supply of any product or service.

www.zetex.com

For the latest product information, log on to

ISSUE 2 - JUNE 2002

