



Size: 11.024 x 6.693 x 2.500 inches
280.00 x 170.00 x 63.50 mm

Weight: 8.38 lbs (3.8kg)

FEATURES

- RoHS Compliant
- Up to 3000 Watts Output Power
- High Efficiency up to 93%
- 3000VAC (4242VDC) I/O Isolation
- Constant Current Limiting
- Global Control via RS232
- Power OK Signal
- High Power Density 16.3W/in³
- UL60950-1 & EN60950-1 Safety Approvals
- Remote Setting Multiple PSU via RS232, RS485 & I²C
- Programmable Output Voltage (0~105%)
- Programmable Output Current (0~105%)
- Universal Input Voltage Range: 90~264VAC (127~370VDC)
- Single Outputs Ranging from 12VDC to 60VDC
- Selectable +5V/0.5A or +9V/0.3A Auxiliary Output
- Forced Current Sharing at Parallel Operation
- Remote ON/OFF, Remote Sense Function
- Protection: OLP, OVP, OTP, SCP, Fan Failure

DESCRIPTION

The PSAEK3000 series of AC/DC switching power supplies provides up to 3000 Watts of output power in an 11.024" x 6.693" x 2.500" enclosed case. This series consists of single output models ranging from 12VDC to 60VDC with a universal input voltage range of 90~264VAC (127~370VDC). Standard features include high efficiency up to 93%, programmable output voltage and output current, remote on/off, and power OK signal. This series also has over temperature, over voltage, over load, and short circuit protection. All models are RoHS compliant and have UL60950-1 and EN60950-1 safety approvals.

MODEL SELECTION TABLE

Model Number	Input Voltage ⁽²⁾	Output Voltage	Output Current	Line Regulation	Load Regulation	Output Power	Ripple & Noise ⁽¹⁾	Efficiency
PSAEK-3000-12	90~264 VAC (127~370 VDC)	12 VDC	200A	±1.0%	±1.0	2400W	150mVp-p	88%
PSAEK-3000-15		15 VDC	160A	±1.0%	±1.0	2400W	150mVp-p	89%
PSAEK-3000-24		24 VDC	125A	±1.0%	±1.0	3000W	150mVp-p	91%
PSAEK-3000-30		30 VDC	100A	±1.0%	±1.0	3000W	150mVp-p	91%
PSAEK-3000-36		36 VDC	83.5A	±1.0%	±1.0	3006W	150mVp-p	92%
PSAEK-3000-48		48 VDC	62.5A	±1.0%	±1.0	3000W	150mVp-p	92%
PSAEK-3000-60		60 VDC	50A	±1.0%	±1.0	3000W	150mVp-p	93%

NOTES

1. Ripple & noise is measured at 20MHz limited bandwidth and using a 12" twisted pair-wire terminated with a 0.1µF & 47µF capacitors in parallel.
2. For voltages near the low end of the input voltage range, see the derating curve for the power supply output rating.
3. When in parallel operation only one unit might operate if the total output load is less than 5% of the rated load condition.
4. The power supply is considered a component which will be installed into final equipment. The final equipment must be re-confirmed that it still meets EMC directives.

DERATING CURVES

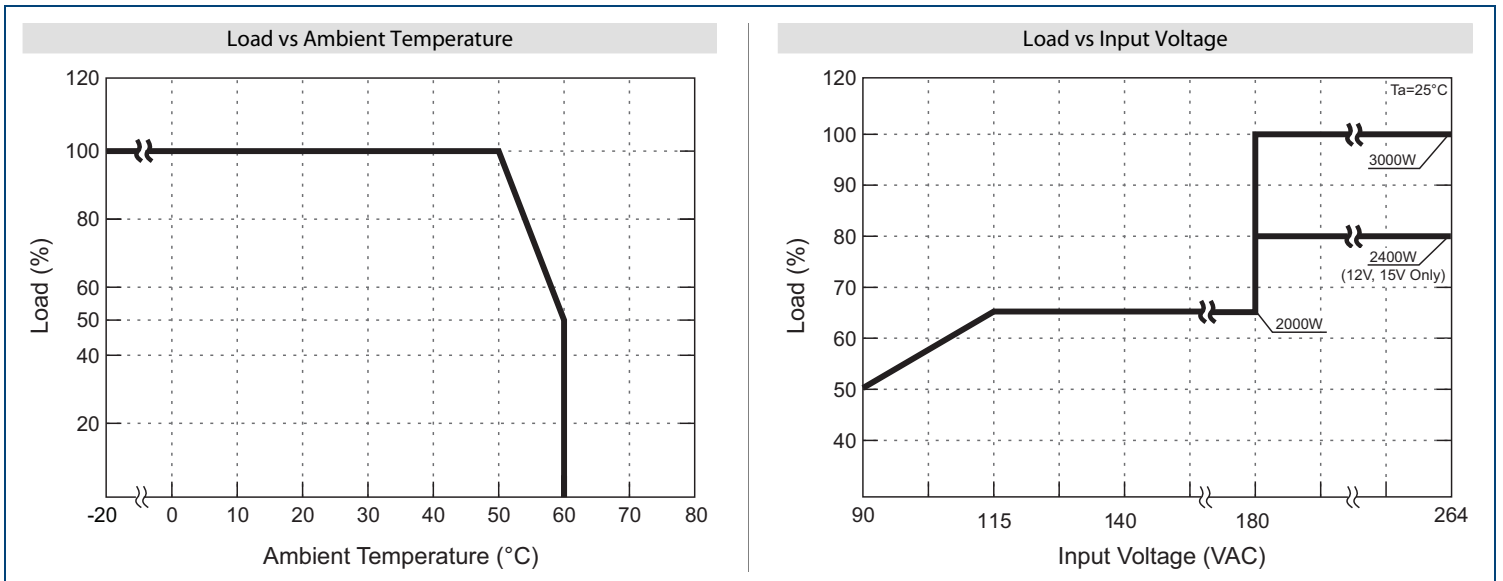

SPECIFICATIONS: PSAEK3000 SERIES						
All specifications are based on 25°C, Nominal Input Voltage, and Maximum Output Current unless otherwise noted. We reserve the right to change specifications based on technological advances.						
SPECIFICATION	TEST CONDITIONS		Min	Typ	Max	Unit
INPUT SPECIFICATIONS						
Input Voltage (See Note 2)	AC input voltage range		90		264	VAC
	DC input voltage range		127		370	VDC
Input Frequency			47		63	Hz
AC Current	At 115VAC (2000W)			19.7		A
	At 230VAC (3000W)			14.5		
Inrush Current	At 115VAC and cold start			33		A
	At 230VAC and cold start			65		
Power Factor	At 115VAC and full load		0.98			
	At 230VAC and full load		0.95			
OUTPUT SPECIFICATIONS						
Output Voltage			See Table			
Voltage Tolerance	Includes set-up tolerance, line regulation, and load regulation		-2.0		+2.0	%
Voltage Adjustability	Typical adjustment by potentiometer (VR1)		-5.0		+5.0	%
Line Regulation	Low Line to High Line		-1.0		+1.0	%
Load Regulation	0% to 100% full load		-1.0		+1.0	%
Output Power			See Table			
Output Current			See Table			
Ripple & Noise (20MHz BW)	Measured with 0.1µF and 47µF capacitors in parallel				150	mVp-p
Hold-up Time	At 230VAC and full load		14			ms
Setup Time	full load			800		ms
Rise Time	full load			50		ms
Temperature Coefficient	0~50°C		-0.02		+0.02	%/°C
PROTECTION						
Over Voltage Protection (see page 4)	Protection type: latch-style. Recovery after reset AC power ON or inhibit		Variable OVP, 120%±7% Vout			
Over Load Protection	Protection type: constant current limit		105% rated output power			
Over Temperature Protection	Protection type: auto-recovery after temperature goes down		85°C±5°C detect on heatsink of pri. & sec. side			
GENERAL SPECIFICATIONS						
Efficiency			See Table			
Isolation Voltage	Input to Output	Test is done without enclosure	3000VAC (4242VDC)			
	Input to FG		1500VAC (2121VDC)			
	Output to FG		500VAC (707VDC)			
Isolation Resistance	Input to Output	500VDC	100			MΩ
	Input to FG	500VDC	100			
	Output to FG	500VDC	100			
Leakage Current	At 240VAC				1.0	mA
FUNCTIONS						
Auxiliary Power			Selectable +5V/0.5A or +9V/0.3A aux. output			
Remote ON/OFF Control (see page 5)	Isolated from output		By external switch			
Power OK Signal	Sink Current: 20mA max.; Drain Voltage: 40V max.		Open drain signal low when PSU turns on			
Output Voltage Trim			0		105	%Vo
Output Current Trim			0		105	%Io
Parallel Operation (Current Sharing)			See page 5			
ENVIRONMENTAL SPECIFICATIONS						
Operating Temperature	See derating curve		-20		+60	°C
Storage Temperature			-40		+85	°C
Operating Humidity	Non-condensing		20		90	% RH
Storage Humidity			10		95	% RH
Cooling			Load and temperature control fan			
Vibration			10~500Hz, 5G 10 min./1 cycle, period for 60 min. each along X, Y, Z axes. Certified IEC60068-2-6, IEC60068-2-64			
PHYSICAL SPECIFICATIONS						
Weight			8.38 lbs (3.8kg)			
Dimensions (W x H x D)			11.024 x 6.693 x 2.500 inches (280.00 x 170.00 x 63.50 mm)			
SAFETY & EMC (See Note 4)						
Safety Approvals			UL60950-1; EN60950-1			
EMI (Conduction & Radiation)			EN55022, EN61204-3, EN61000-6-3			
Harmonic & Flicker			EN61000-3-2; EN61000-3-3			
EMS Immunity			EN55024; EN61204-3; EN61000-6-1; IEC61000-4-2, 3, 4, 5, 6, 8, 11			

MECHANICAL DRAWING

Unit: inches [mm]

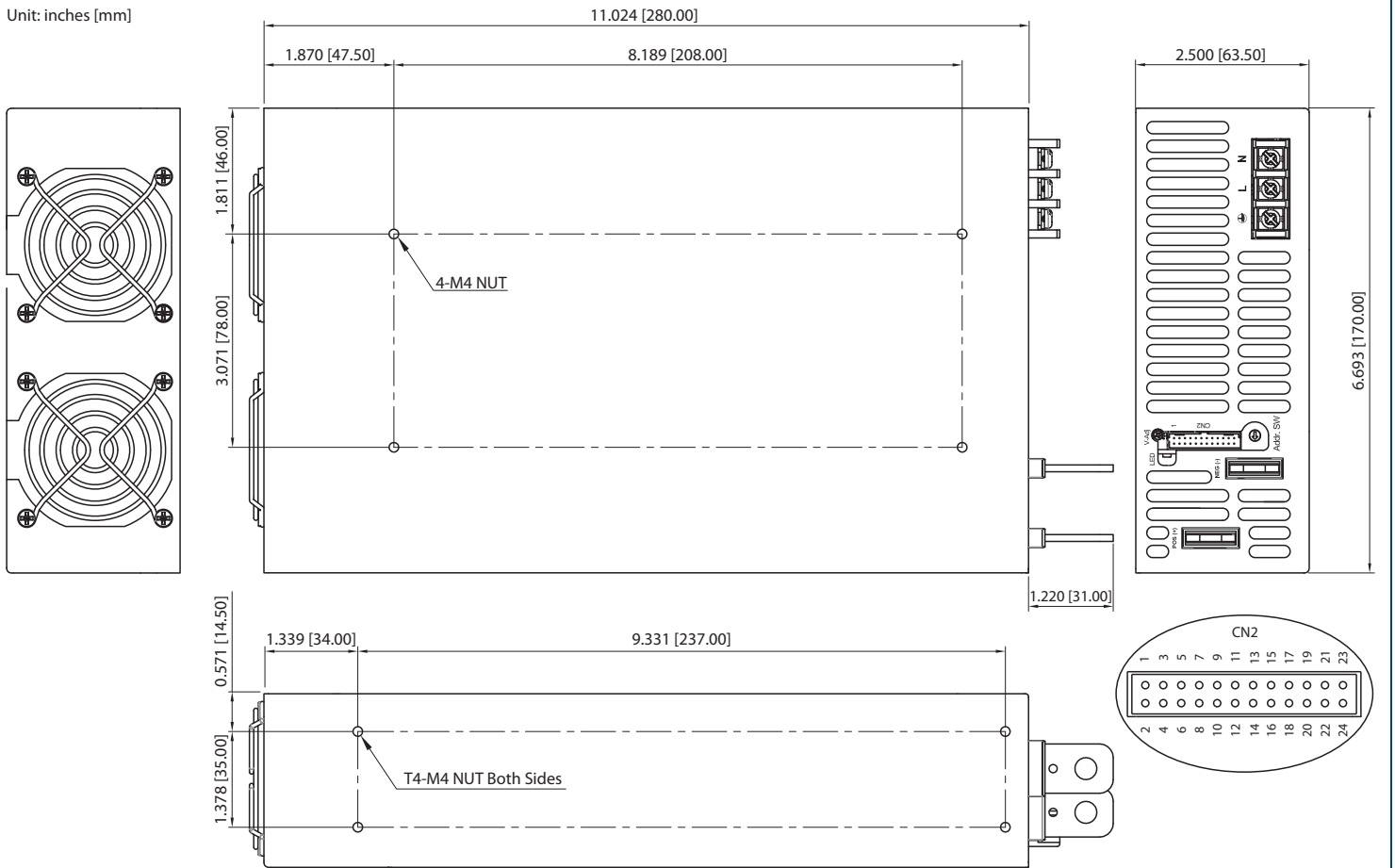

AC Input Terminal	
Pin	Function
1	ACL
2	ACN
3	⏏

Control Pin Number Assignment (CN2): JST S24B-PHDS or Equivalent					
Pin	Function	Description	Pin	Function	Description
1	VS+	Positive Output Voltage	13	ACI	I Program
2	VO+	Remote Sense (+)	14	GND	Ground
3	VS-	Remote Sense (-)	15	VCI	V Program
4	VO-	Negative Output Voltage	16	GND	Ground
5	POK	Power OK	17	AUX	+5V/0.5A or +9V/0.3A Auxiliary Power
6	GND	Ground	18	GND	Ground
7	PAR	Parallel Operation Current Sharing	19	SCL	Serial Clock used in the I ² C Interface
8	VSET	AUX Output Set	20	SDA	Serial Data used in the I ² C Interface
9	EN-	Inhibit ON/OFF (-)	21	AUX	+5V/0.5A or +9V/0.3A Auxiliary Power
10	GND	Ground	22	GND	Ground
11	EN+	Inhibit ON/OFF (+)	23	NC	For RS232 Transmission Function
12	AUX	+5V/0.5A or +9V/0.3A Auxiliary Power	24	NC	For RS232 Receiver Function

CN2 Connector Housing	
Mating Housing	Contact
JST PHDR-24VS or equivalent	JST SPHD-002T-P0.5 or equivalent

LED STATUS

LED	LED Signal	Status
Solid (Green)		Power OK (Local Mode)
Solid (Orange)		Power OK (Remote Mode)
Slow Blink (Green)		Power Standby
Fast Blink (Red)		Over Voltage Protection (OVP)
Solid (Red)		Over Load Protection (OLP)
Slow Blink (Red)		Over Temperature Protection (OTP)
Intermittent Blink (Red)		Fan Failure
Interlace Blink (Red)		Power Failure

- * Local mode: Use ACI/VCI to control output current and voltage
- * Remote Mode: Use RS232 or I²C command to control output current and voltage

CURVES

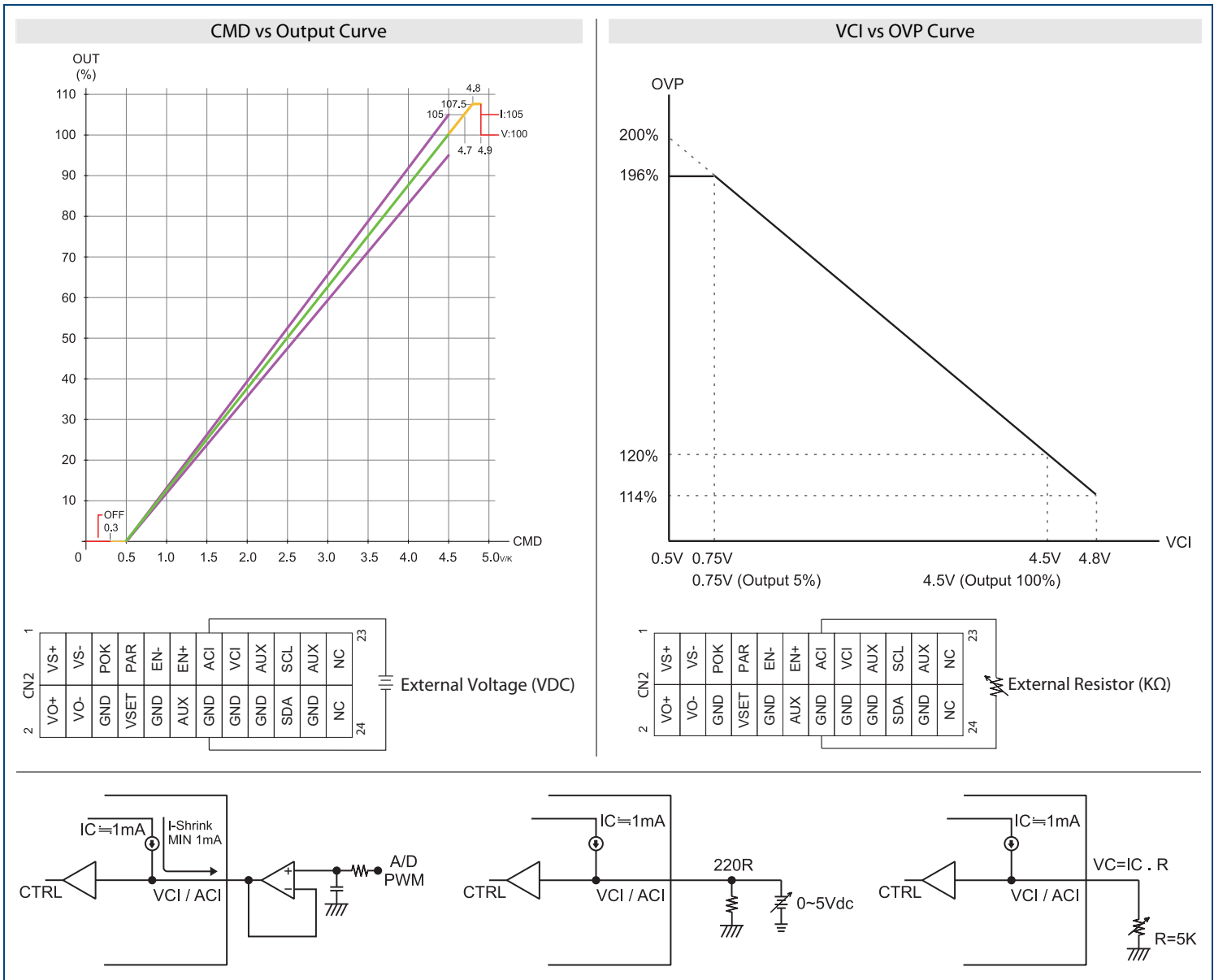

REMOTE ON/OFF

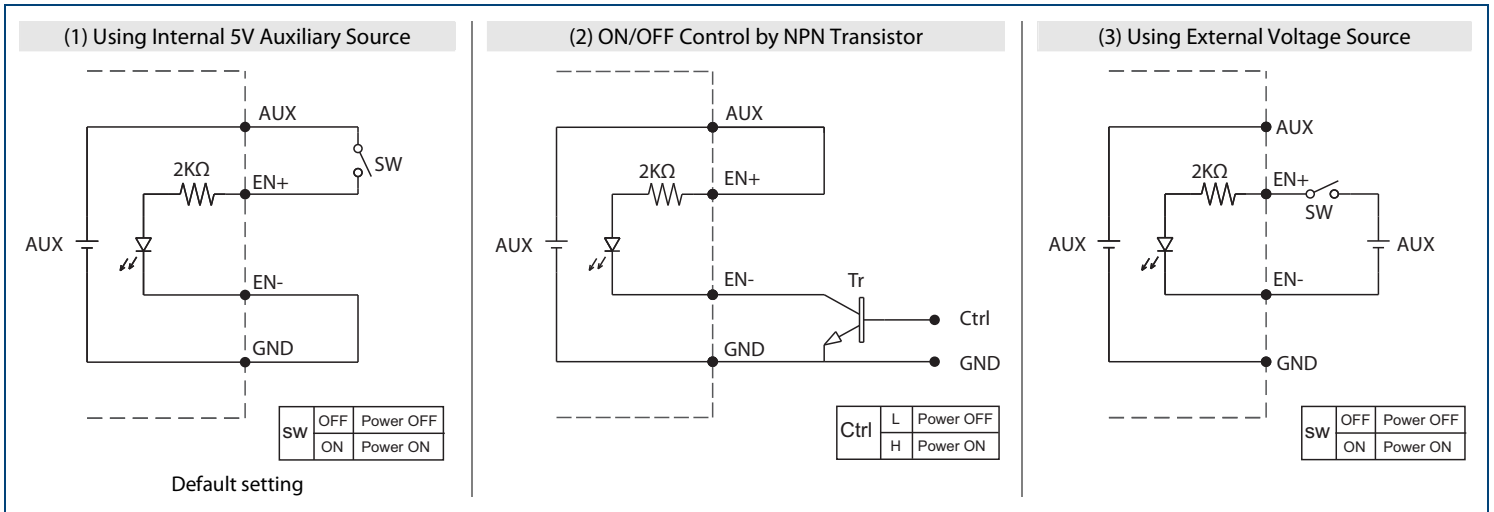

POWER OK SIGNAL

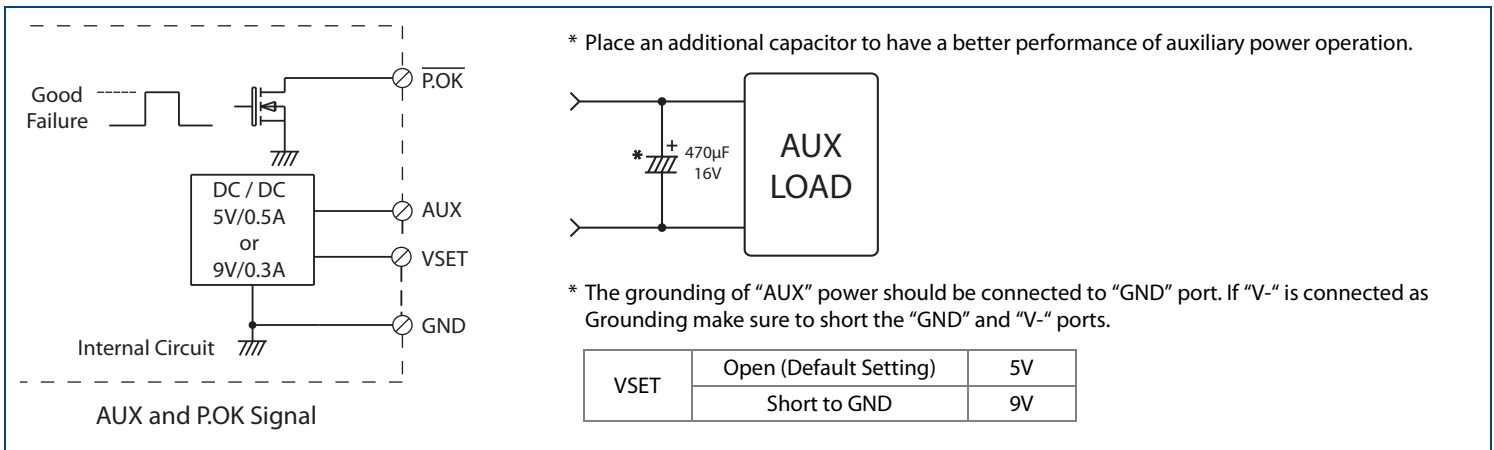

REMOTE SENSE

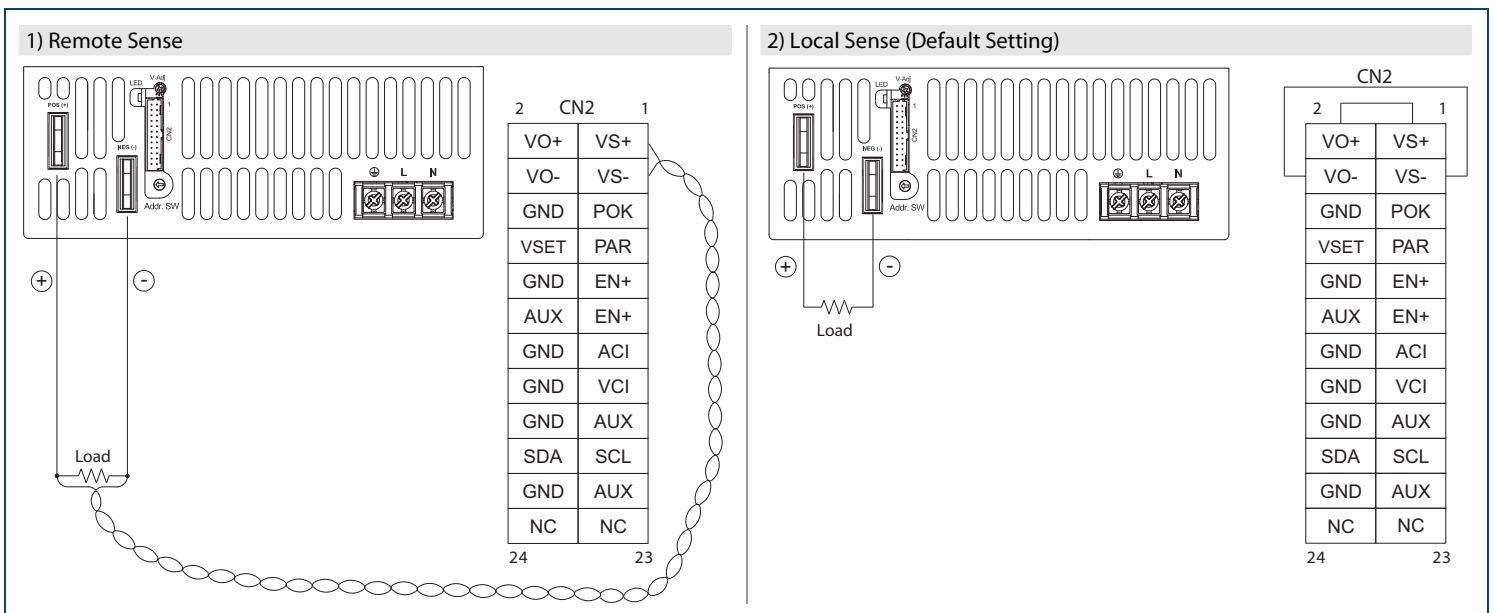

CURRENT SHARING

3) Current Sharing with Remote Sense

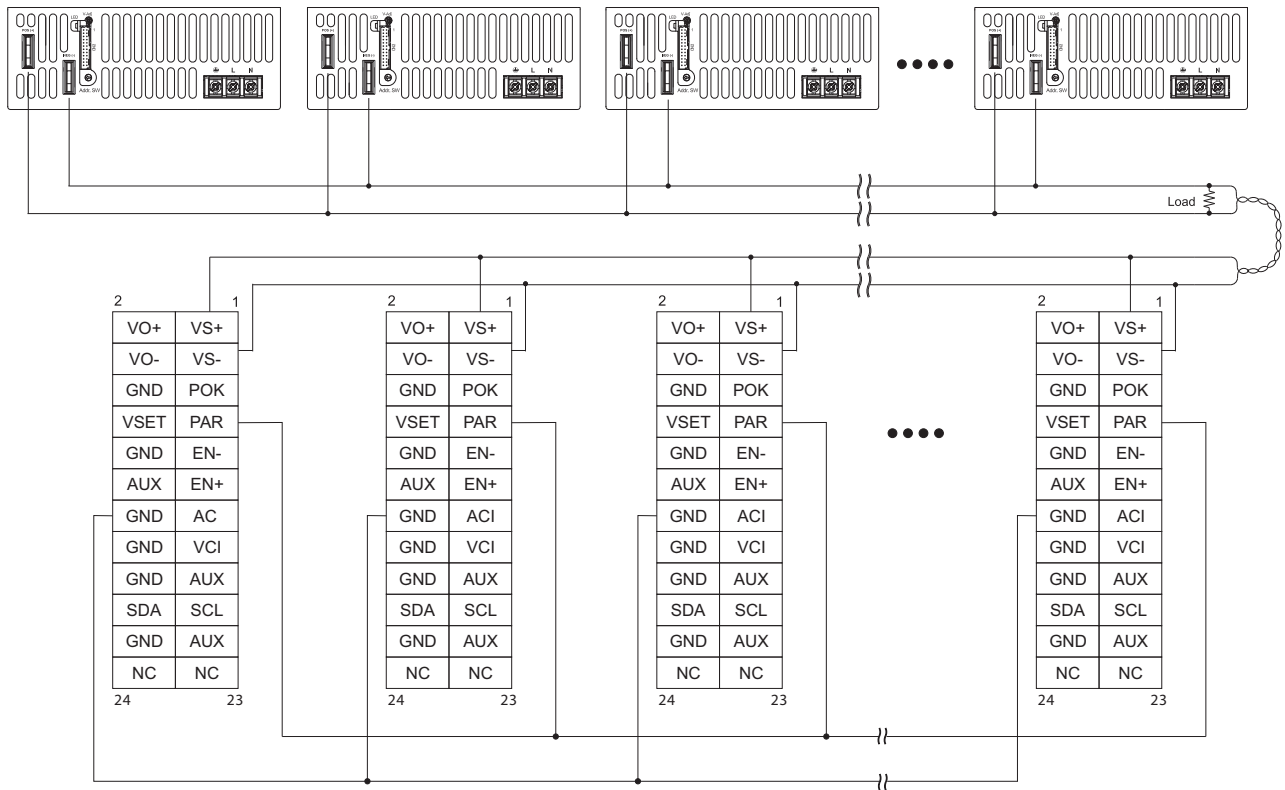

4) Current Sharing with Local Sensing

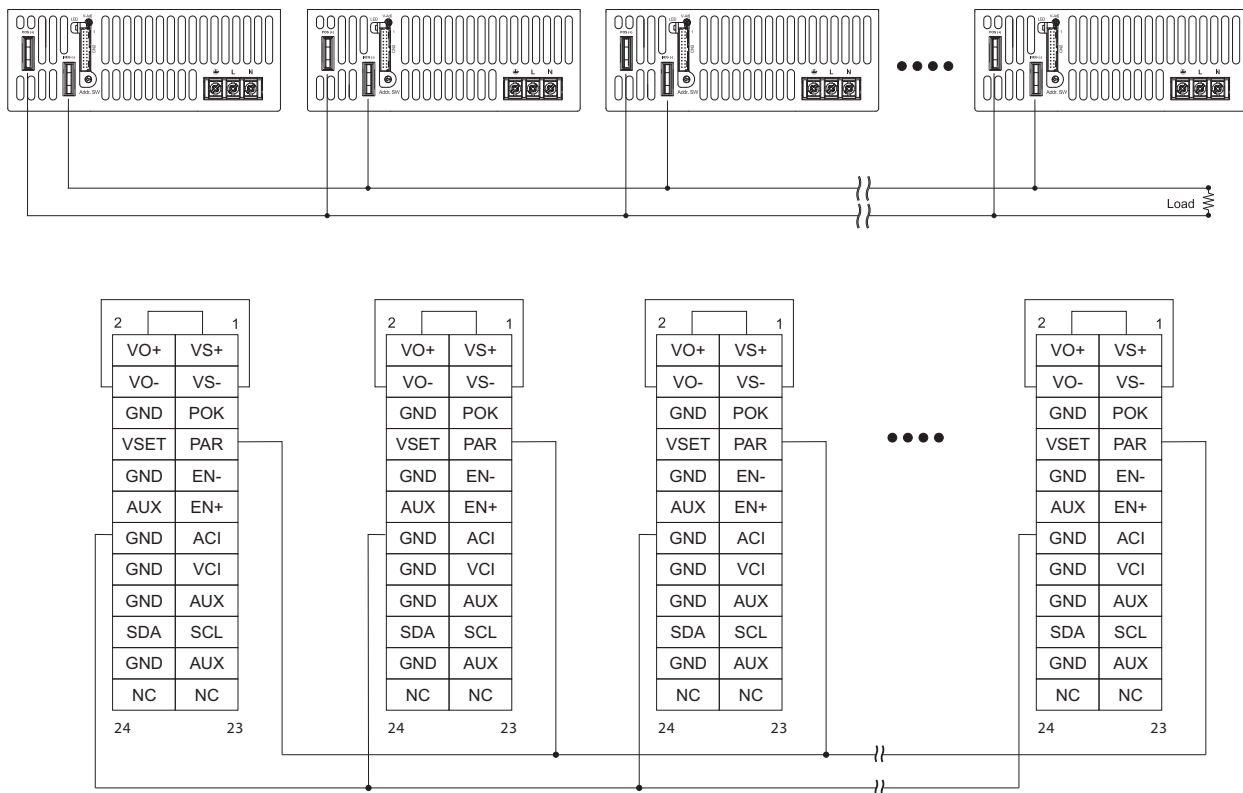

INSTALLATION INSTRUCTIONS

1. Mounting Directions

1-1 Recommended Standard Mounting Methods

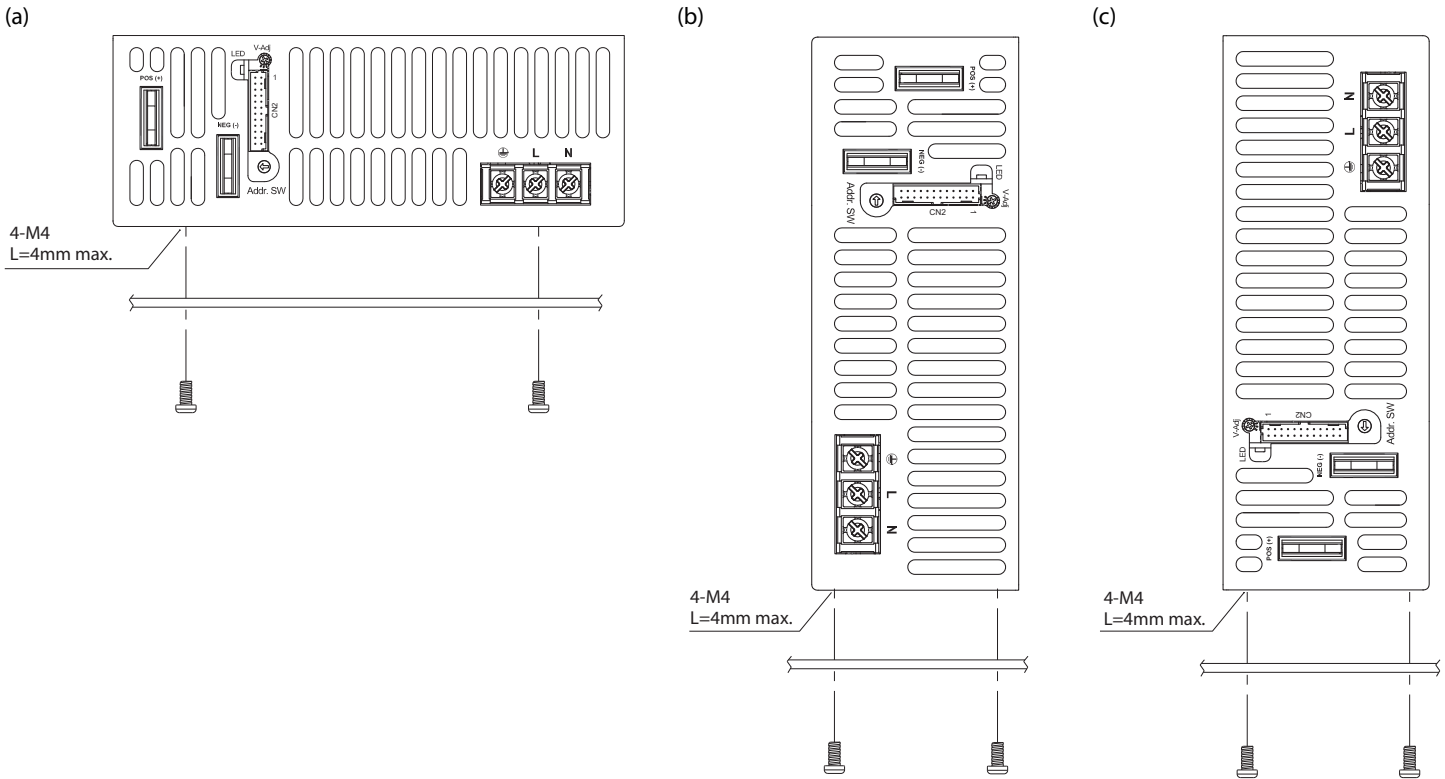

2. Mounting Method

- 2-1 There are ventilating holes on the front and back side panels. Do not obstruct; allow at least 50mm for airflow
- 2-2 The maximum allowable penetration for the screw is 4mm. Incomplete threading should not be penetrated.
- 2-3 Recommended torque of mounting screw: M4 screw: 1.27N • m (13.0kgf • cm)

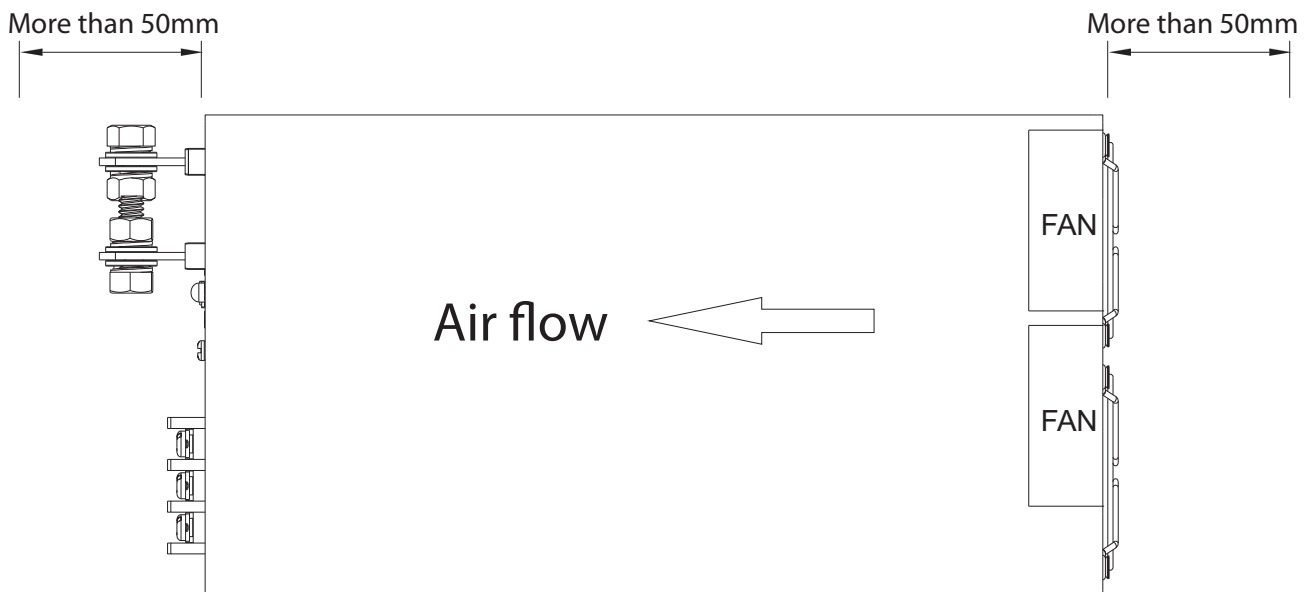

COMPANY INFORMATION

Wall Industries, Inc. has created custom and modified units for over 50 years. Our in-house research and development engineers will provide a solution that exceeds your performance requirements on-time and on budget. Our ISO9001-2008 certification is just one example of our commitment to producing a high quality, well-documented product for our customers.

Our past projects demonstrate our commitment to you, our customer. Wall Industries, Inc. has a reputation for working closely with its customers to ensure each solution meets or exceeds form, fit and function requirements. We will continue to provide ongoing support for your project above and beyond the design and production phases. Give us a call today to discuss your future projects.

Contact **Wall Industries** for further information:

Phone:	☎(603)778-2300
Toll Free:	☎(888)597-9255
Fax:	☎(603)778-9797
E-mail:	sales@wallindustries.com
Web:	www.wallindustries.com
Address:	37 Industrial Drive Exeter, NH 03833